

1 2 3 4 5 6 7

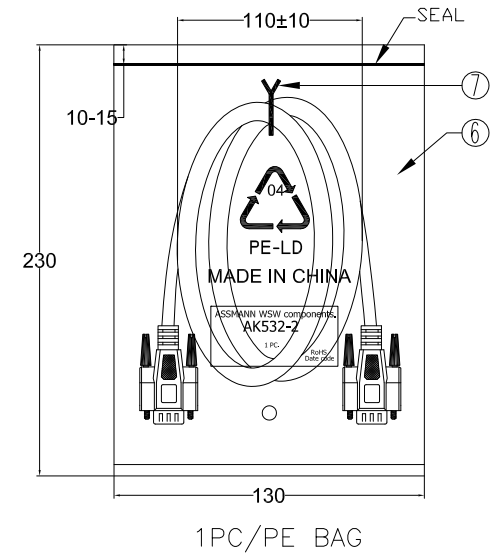
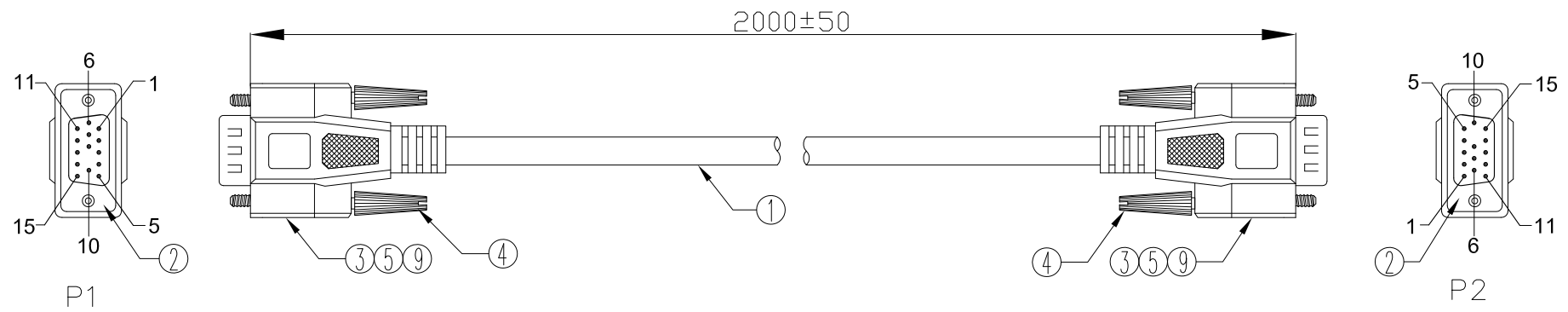

**PIN ASSIGNMENT**

P1	P2
1	1
2	2
3	3
4	4
5	5
6	6
7	7
8	8
10	10
11	11
12	12
13	13
14	14
15	15
Shell	Shell

**Electrical test:**  
 1. 100% short, open, miss wire test  
 2. Conduct resistance: 2 Ohm(max)  
 3. Insulation resistance: 5 Mohm(min)  
 4. Dielectric test: DC 300V/10ms

NO.	NAME	Q'TY	SPECIFICATION
⑨	TUBE	2	HEAT SHRINK TUBE BLACK OD1.5*L=15MM
⑧	PE BAG	1/10	CLEAR SIZE:280*330*0.05mm PRINT BLACK"MADE IN CHINA"+"10PCS".
⑦	TIE	1	WHITE L=120mm
⑥	PE BAG	1	CLEAR SIZE:130*230*0.05mm PRINT BLACK"MADE IN CHINA".
⑤	COPPER FOIL	2	DOUBLE-SIDED CONDUCTIVE COPPER FOIL 18U" W25mm*L55mm
④	SCREW	4	SCREW:#4-40UNC D-E L32.5mm,NICKEL PLATED,INSULATION COLOR BEIGE(IV-29)
	OUT JACKET	43.5g	BEIGE(IV-29) 40P PVC(MOULD NO:WM-113)
③	IN JACKET	8g	CLEAR LDPE(MOULD NO:NM-049)
②	CONN	1	HDD15P MALE,PIN G/F.SHELL-NICKEL,INSULATION COLOR:BLUE. MISSING 9PIN SOLDER TYPE.
①	CABLE	1	NOUL 28AWG*14C+AL/MY+D.W(7/0.12 TC) OUTTER JACKET COROL:BEIGE(IV-29) OD:6.0±0.15mm. L=2000±20mm.

**RoHS compliant**  
Unit: mm

Scale	Free					Date	Name	Customer-No.
TOLERANCE						Drawn	20.02.2017	Amy
						Approved	04.09.2017	Fred
DIM	TOL	①	Delete the wire color for pin assignment	04.09.2017	Fred			
		②	Drawn	20.02.2017	Amy			
Angle	TOL	Id.	Modification	Date	Name	Replace		Sheet

ASSMANN WSW-No. **AK532-2**

Drawing-No. **ASS 7890 CA** rev01

1 2 3 4 5 6 7