

YXF シリーズ
SERIES

105°C 長寿命品
105°C Long Life

・105°C 4000~10000時間品。
Load Life : 105°C 4000~10000 hours.

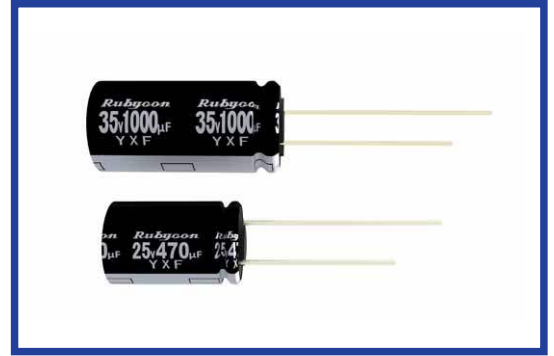

◆規格表 / SPECIFICATIONS

項目 Items	特性 Characteristics																														
カテゴリ温度範囲 Category Temperature Range	-40~+105°C																														
定格電圧範囲 Rated Voltage Range	6.3~100Vdc																														
静電容量許容差 Capacitance Tolerance	±20%(20°C,120Hz)																														
漏れ電流 Leakage Current(MAX)	I=0.01CV又は3µAのいずれか大なる値以下(定格電圧印加2分後) I=0.01CV or 3µA whichever is greater. (After 2 minutes) I=漏れ電流(µA) Leakage Current C=静電容量(µF) Capacitance V=定格電圧(Vdc) Rated Voltage																														
損失角の正接(tanδ) Dissipation Factor(MAX)	<table border="1"> <tr> <td>定格電圧(Vdc) Rated Voltage</td> <td>6.3</td><td>10</td><td>16</td><td>25</td><td>35</td><td>50</td><td>63</td><td>100</td> <td>(20°C,120Hz)</td> </tr> <tr> <td>tanδ</td> <td>0.22</td><td>0.19</td><td>0.16</td><td>0.14</td><td>0.12</td><td>0.10</td><td>0.09</td><td>0.08</td> <td></td> </tr> </table> <p>1000µFを越えるものは1000µF増す毎に上表の値に0.02を加えた値とする。 When capacitance is over 1000µF, tanδ shall be added 0.02 to the listed value with increase of every 1000µF.</p>	定格電圧(Vdc) Rated Voltage	6.3	10	16	25	35	50	63	100	(20°C,120Hz)	tanδ	0.22	0.19	0.16	0.14	0.12	0.10	0.09	0.08											
定格電圧(Vdc) Rated Voltage	6.3	10	16	25	35	50	63	100	(20°C,120Hz)																						
tanδ	0.22	0.19	0.16	0.14	0.12	0.10	0.09	0.08																							
耐久性 Endurance	<p>105°C中で右表の時間定格電圧(リップル重畳)印加後、下記項目を満足すること。 After applying rated voltage with rated ripple current for specified time at 105°C, the capacitors shall meet the following requirements.</p> <table border="1"> <tr> <td>静電容量変化率 Capacitance Change</td> <td>初期値の±25%以内 Within ±25% of the initial value.</td> <td>ケースサイズ Case Size</td> <td colspan="2">時間(hrs) Life Time</td> </tr> <tr> <td>損失角の正接 Dissipation Factor</td> <td>規格値の200%以下 Not more than 200% of the specified value.</td> <td>φD≤6.3</td> <td>6.3~10Vdc</td> <td>16~100Vdc</td> </tr> <tr> <td>漏れ電流 Leakage Current</td> <td>規格値以下 Not more than the specified value.</td> <td>φD=8,10</td> <td>4000</td> <td>5000</td> </tr> <tr> <td></td> <td></td> <td>φD≥12.5</td> <td>6000</td> <td>7000</td> </tr> <tr> <td></td> <td></td> <td></td> <td>8000</td> <td>10000</td> </tr> </table>	静電容量変化率 Capacitance Change	初期値の±25%以内 Within ±25% of the initial value.	ケースサイズ Case Size	時間(hrs) Life Time		損失角の正接 Dissipation Factor	規格値の200%以下 Not more than 200% of the specified value.	φD≤6.3	6.3~10Vdc	16~100Vdc	漏れ電流 Leakage Current	規格値以下 Not more than the specified value.	φD=8,10	4000	5000			φD≥12.5	6000	7000				8000	10000					
静電容量変化率 Capacitance Change	初期値の±25%以内 Within ±25% of the initial value.	ケースサイズ Case Size	時間(hrs) Life Time																												
損失角の正接 Dissipation Factor	規格値の200%以下 Not more than 200% of the specified value.	φD≤6.3	6.3~10Vdc	16~100Vdc																											
漏れ電流 Leakage Current	規格値以下 Not more than the specified value.	φD=8,10	4000	5000																											
		φD≥12.5	6000	7000																											
			8000	10000																											
低温特性 Low Temperature Stability (インピーダンス比) Impedance Ratio(MAX)	<table border="1"> <tr> <td>定格電圧(Vdc) Rated Voltage</td> <td>6.3</td><td>10</td><td>16</td><td>25</td><td>35</td><td>50</td><td>63</td><td>100</td> <td>(120Hz)</td> </tr> <tr> <td>Z(-25°C)/Z(20°C)</td> <td>4</td><td>3</td><td>2</td><td>2</td><td>2</td><td>2</td><td>2</td><td>2</td> <td></td> </tr> <tr> <td>Z(-40°C)/Z(20°C)</td> <td>8</td><td>6</td><td>4</td><td>3</td><td>3</td><td>3</td><td>3</td><td>3</td> <td></td> </tr> </table>	定格電圧(Vdc) Rated Voltage	6.3	10	16	25	35	50	63	100	(120Hz)	Z(-25°C)/Z(20°C)	4	3	2	2	2	2	2	2		Z(-40°C)/Z(20°C)	8	6	4	3	3	3	3	3	
定格電圧(Vdc) Rated Voltage	6.3	10	16	25	35	50	63	100	(120Hz)																						
Z(-25°C)/Z(20°C)	4	3	2	2	2	2	2	2																							
Z(-40°C)/Z(20°C)	8	6	4	3	3	3	3	3																							

◆リップル電流補正係数 / MULTIPLIER FOR RIPPLE CURRENT

周波数(Hz) Frequency	120	1k	10k	100k≤
1µF	0.35	0.60	0.80	1.00
2.2~10µF	0.42	0.60	0.80	1.00
22~33µF	0.55	0.75	0.90	1.00
47~330µF	0.70	0.85	0.95	1.00
470~1000µF	0.75	0.90	0.98	1.00
2200~15000µF	0.80	0.95	1.00	1.00

◆寸法図 / DIMENSIONS (mm)

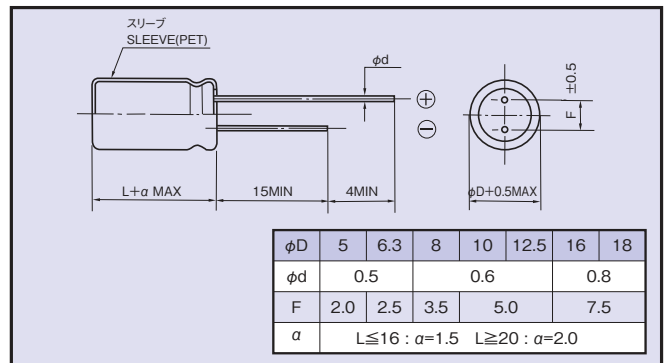

◆呼称方法 / PART NUMBER

□□□	YXF	□□□□□	M	□□□	□□	DXL
定格電圧 Rated Voltage	シリーズ名 Series	静電容量 Capacitance	静電容量許容差 Capacitance Tolerance	副記号 Option	リード加工記号 Lead Forming	ケースサイズ Case Size

◆副記号 / OPTION

	記号 Code
PETスリーブ PET Sleeve	EFC

◆標準品一覧表 / STANDARD SIZE

定格電圧 Rated Voltage (Vdc)	静電容量 Capacitance (μ F)	外形寸法 Size ϕ D×L(mm)	定格リプル電流 Rated ripple current (mA r.m.s./105°C, 100kHz)	インピーダンス(Ω MAX) Impedance	
				20°C, 100kHz	-10°C, 100kHz
6.3	100	5×11	150	0.90	3.6
	220	6.3×11	250	0.40	1.6
	330	6.3×11	250	0.40	1.6
	470	8×11.5	400	0.25	1.0
	1000	10×12.5	580	0.16	0.65
	2200	12.5×20	1300	0.062	0.21
	3300	12.5×20	1300	0.062	0.21
	4700	16×25	1850	0.034	0.096
	6800	16×25	1850	0.034	0.096
	10000	16×31.5	2000	0.029	0.087
15000	18×35.5	2200	0.025	0.058	
10	100	5×11	150	0.90	3.6
	220	6.3×11	250	0.40	1.6
	330	8×11.5	400	0.25	1.0
	470	8×11.5	400	0.25	1.0
	1000	10×16	770	0.12	0.46
	2200	12.5×20	1300	0.062	0.21
	3300	12.5×25	1650	0.048	0.16
	4700	16×25	1850	0.034	0.096
	6800	16×31.5	2000	0.029	0.087
	10000	18×35.5	2200	0.025	0.058
16	47	5×11	150	0.90	3.6
	100	6.3×11	250	0.40	1.6
	220	8×11.5	400	0.25	1.0
	330	8×11.5	400	0.25	1.0
	470	10×12.5	580	0.16	0.65
	1000	10×20	1050	0.078	0.30
	2200	12.5×25	1650	0.048	0.16
	3300	16×25	1850	0.034	0.096
	4700	16×31.5	2000	0.029	0.087
	6800	18×35.5	2200	0.025	0.058
25	33	5×11	150	0.90	3.6
	47	5×11	150	0.90	3.6
	100	6.3×11	250	0.40	1.6
	220	8×11.5	400	0.25	1.0
	330	10×12.5	580	0.16	0.65
	470	10×16	770	0.12	0.46
	1000	12.5×20	1300	0.062	0.21
	2200	16×25	1850	0.034	0.096
	3300	16×31.5	2000	0.029	0.087
	4700	18×35.5	2200	0.025	0.058
35	33	5×11	150	0.90	3.6
	47	6.3×11	250	0.40	1.6
	100	8×11.5	400	0.25	1.0
	220	10×12.5	580	0.16	0.65
	330	10×16	770	0.12	0.46
	470	10×20	1050	0.078	0.30
	1000	12.5×25	1650	0.048	0.16
	2200	16×31.5	2000	0.029	0.087
3300	18×35.5	2200	0.025	0.058	

定格電圧 Rated Voltage (Vdc)	静電容量 Capacitance (μ F)	外形寸法 Size ϕ D×L(mm)	定格リプル電流 Rated ripple current (mA r.m.s./105°C, 100kHz)	インピーダンス(Ω MAX) Impedance	
				20°C, 100kHz	-10°C, 100kHz
50	1	5×11	30	4.0	8.0
	2.2	5×11	43	2.5	6.0
	3.3	5×11	53	2.2	5.6
	4.7	5×11	88	1.9	5.0
	10	5×11	100	1.5	4.0
	22	5×11	150	0.90	3.6
	33	6.3×11	250	0.40	1.6
	47	6.3×11	250	0.40	1.6
	100	8×11.5	400	0.25	1.0
	220	10×16	770	0.12	0.46
	330	10×20	1050	0.078	0.30
	470	12.5×20	1300	0.062	0.21
	1000	16×25	1850	0.034	0.096
	2200	18×35.5	2200	0.025	0.058
63	10	5×11	87	2.3	9.3
	22	6.3×11	140	1.3	5.2
	33	6.3×11	140	1.2	5.0
	47	8×11.5	210	0.63	2.8
	100	10×12.5	300	0.43	1.8
	220	10×20	520	0.21	0.84
	330	12.5×20	660	0.16	0.64
	470	12.5×25	750	0.12	0.5
	1000	16×25	1850	0.034	0.12
	2200	18×35.5	2200	0.025	0.058
100	1	5×11	30	4.0	8.0
	2.2	5×11	43	3.0	12.0
	3.3	5×11	40	2.7	11.0
	4.7	5×11	65	2.5	10.0
	10	6.3×11	140	1.2	5.0
	22	8×11.5	160	0.63	2.8
	33	10×12.5	230	0.43	1.8
	47	10×16	290	0.31	1.5
	100	12.5×20	430	0.16	0.64
	220	16×25	900	0.073	0.27
	330	16×25	900	0.073	0.27

新規採用非推奨品
NOT recommended for new designs