

Description

ToF HAT is a high precision laser-ranging sensor specifically designed for M5StickC. Integrated with VL53L0X and 940nm VCSEL emitter. It can provide high precision and low latency performance on object distance detection. The VL53L0X is a new generation Time-of-Flight (ToF) laser-ranging module housed in the smallest package on the market today, providing accurate distance measurement whatever the target reflectances, unlike conventional technologies. It can measure absolute distances up to 2m, setting a new benchmark in ranging performance levels, opening the door to various new applications. The VL53L0X integrates a leading-edge SPAD array (Single Photon Avalanche Diodes) and embeds ST's second generation FlightSense™ patented technology. The VL53L0X's 940 nm VCSEL emitter (Vertical-Cavity Surface-Emitting Laser), is invisible to the human eye, coupled with internal physical infrared filters, it enables longer ranging distances, higher immunity to ambient light, and better robustness to cover glass optical crosstalk.

Communication Info: I2C, 0x29, GPIO0/26.

Product Features

- High precision
- Maximum measuring distance 2m
- 940nm laser VCSEL
- Development platform: Arduino, UIFlow(Blockly,Python)
- Security:
 - Class 1 laser equipment meeting the latest standards
 - Standard IEC60825-1: 2014 - 3rd edition
- Dimension: 24mm x 20.3mm x 13.8mm
- Weight: 3g

Include

- 1x ToFHAT

Applications

- Obstacle recognition
- Gesture Recognition
- Laser Ranging
- 3D structured light imaging (3D sensing)
- Camera assist (super fast auto focus and depth of field map)

Links

[VL53L0X Datasheet](#)

Schematic

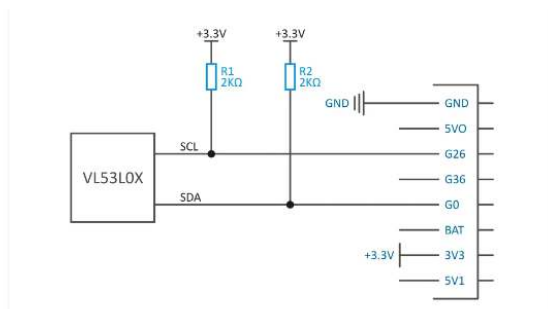

[click to download EasyLoader](#)

1. EasyLoader is a simple and fast program burner. Every product page in EasyLoader provides a product-related case program. It can be burned to the master through simple steps, and a series of function verification can be performed. (Currently, EasyLoader is only available for Windows OS)

After downloading the software, double-click to run the application, connect the M5 device to the computer through the data cable, select the port parameters, click "Burn" to start burning. (For M5StickC burning, please Set the baud rate to 750000 or 115200)

Example

UIFlow



Arduino

To get complete code, please click [here](#)

Pin Map

MSStickC GPIO0 GPIO26 3.3V GND

ToF HAT SDA SCL 3.3V GND