

171021801

MagI³C Power Module WPME-VDLM – Variable Step Down LGA Module

4V – 18V / 2A / 0.8V – 17V Output



DESCRIPTION

The VDLM series of the MagI³C Power Module family provides a fully integrated DC-DC power supply including the buck switching regulator, inductor, input and output capacitors in a package, allowing a minimum external components count solution, quick time to market and ease of use.

The 171021801 family offers high efficiency and delivers up to 2A of output current. It operates from 4V input voltage up to 18V. It is designed for fast transient response.

It is available in an innovative industrial high power density LGA-16EP (9 x 9 x 3mm) package that enhances thermal performance.

The VDLM regulators have an integrated protection circuit that guards against thermal overstress and electrical damage by using thermal shut-down, overcurrent, short-circuit, and undervoltage protection.

TYPICAL APPLICATIONS

- Point-of-Load DC-DC applications from 5V, 9V and 12V industrial rails
- Industrial, test & measurement, medical applications
- System power supplies
- DSPs, FPGAs, MCUs and MPUs supply
- I/O interface power supply

FEATURES

- Peak efficiency up to 95%
- Current capability: 2A
- Input voltage range: 4V to 18V
- Output voltage range: 0.8V to 17V
- Reference accuracy: $\pm 1.5\%$
- No minimum load required
- Integrated input and output capacitors
- Integrated shielded inductor
- Exposed pads for best-in-class thermal performance
- Low output voltage ripple ($< 20mV_{pp}$)
- Fixed switching frequency: 850kHz
- Peak Current Mode control
- Internal soft-start
- Synchronous operation
- Automatic power saving operation at light load
- Undervoltage lockout protection (UVLO)
- Thermal shutdown
- Short circuit protection
- Cycle-by-cycle current limit
- Operating ambient temperature up to 85°C
- RoHS and REACH compliant
- Operating junction temp. range: -40 to 125°C
- Complies with EN55022 class B radiated emissions standard

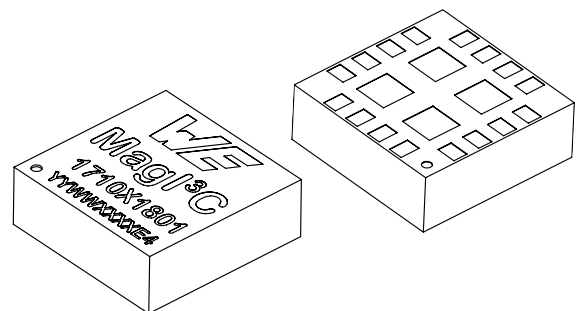

TYPICAL CIRCUIT DIAGRAM

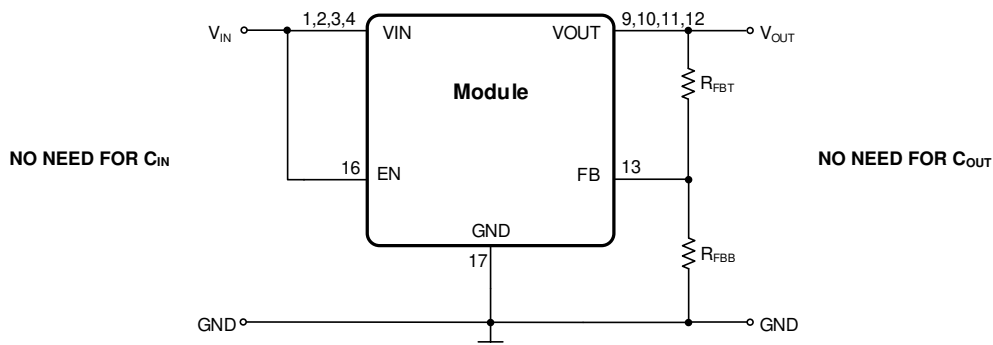

171021801

MagI³C Power Module WPME-VDLM – Variable Step Down LGA Module



PACKAGE

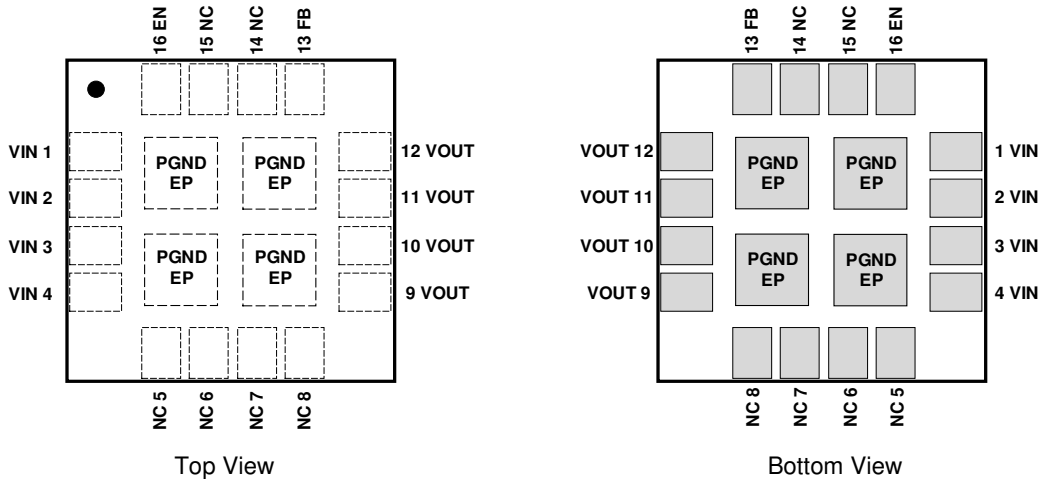

MARKING DESCRIPTION

Marking	Description
WE	Würth Elektronik tradename
MagI ³ C	MagI ³ C Logo
171021801	Order Code
YYWW	Date Code
XXXX	Tracking Code
E4	Lead finish code per Jedec



PIN DESCRIPTION

SYMBOL	NUMBER	TYPE	DESCRIPTION
VIN	1,2,3,4	Power	The supply input pins are a terminal for an unregulated input voltage source. These pins are internally connected together. Connect externally all together with a single PCB track.
VOUT	9,10,11,12	Power	The output voltage pins are connected to the internal inductor. These pins are internally connected together. Connect externally all together with a single PCB track.
FB	13	Input	The feedback pin is internally connected to the regulation circuitry. The regulation reference point is 0.8V at this input pin. Connect the feedback resistor divider between the output and GND to set the output voltage.
EN	16	Input	Connecting this pin to a voltage lower than 0.4V (e.g. GND) disables the device. Connecting this pin to a voltage higher than 1.2V enables the device. This pin is connected to ground through an internal pull-down resistor. Therefore leaving this pin open disables the device.
PGND	EP	Exposed Pads	These pins are the ground connection of the device. All pins must be connected together externally with a copper plane for heat sinking
NC	5,6,7,8,14,15	Not connected	These pins are not connected to the internal circuitry and are not connected to each other. They can be left floating

171021801

MagI³C Power Module
WPME-VDLM – Variable Step Down LGA Module



ORDERING INFORMATION

ORDER CODE	PART DESCRIPTION	SPECIFICATIONS	PACKAGE	PACKAGING UNIT
171021801	WPMDL1201801LD	2A / 0.8-17Vout	LGA-16EP	Tape and Reel, 1000 pieces
178021801	WPMDL1201801JEV	2A / 0.8-17Vout	Eval Board	1

PIN COMPATIBLE FAMILY MEMBERS

ORDER CODE	PART DESCRIPTION	SPECIFICATIONS	PACKAGE	PACKAGING UNIT
171011801	WPMDL1101801LD	1A / 0.8-17Vout	LGA-16EP	Tape and Reel, 1000 pieces
178011801	WPMDL1101801JEV	1A / 0.8-17Vout	Eval Board	1
171031801	WPMDL1301801LD	3A / 0.8-17Vout	LGA-16EP	Tape and Reel, 1000 pieces
178031801	WPMDL1301801JEV	3A / 0.8-17Vout	Eval Board	1

SALES INFORMATION

SALES CONTACTS
<p>Würth Elektronik eiSos GmbH & Co. KG EMC & Inductive Solutions Max-Eyth-Str. 1 74638 Waldenburg Germany Tel. +49 (0) 7942 945 0 www.we-online.com powermodules@we-online.com</p>

171021801

MagI³C Power Module

WPME-VDLM – Variable Step Down LGA Module



ABSOLUTE MAXIMUM RATINGS

Caution:

Exceeding the listed absolute maximum ratings may affect the device negatively and may cause permanent damage.

SYMBOL	PARAMETER	LIMITS		UNIT
		MIN ⁽¹⁾	MAX ⁽¹⁾	
V _{IN}	Input voltage	-0.3	20	V
V _{OUT}	Output voltage	-1	V _{IN}	V
FB	FB input voltage	-0.3	2.5	V
EN	EN input voltage	-0.3	V _{IN}	
V _{ESD}	ESD voltage (Human Body Model), according to EN61000-4-2 ⁽²⁾	-	±2000	V
T _J	Junction temperature	-40	150	°C
T _{storage}	Assembled, non-operating storage temperature	-55	150	°C
T _{SOLDER}	Peak case/leads temperature during reflow soldering, max.20sec ⁽³⁾	230	240	°C

OPERATING CONDITIONS

Operating conditions are conditions under which the device is intended to be functional. All values are referenced to GND.

SYMBOL	PARAMETER	MIN ⁽¹⁾	TYP ⁽⁴⁾	MAX ⁽¹⁾	UNIT
V _{IN}	Input voltage	4	-	18	V
V _{OUT}	Regulated output voltage	0.8	-	17	V
I _{OUT}	Nominal output current	-	-	2	A
T _A	Ambient temperature range	-40	-	85 ⁽⁵⁾	°C
T _J	Junction temperature range	-40	-	125	°C

THERMAL SPECIFICATIONS

SYMBOL	PARAMETER	TYP ⁽⁴⁾	UNIT
Θ _{JA}	Junction-to-ambient thermal resistance ⁽⁶⁾	22	°C/W
T _{SD}	Thermal shutdown, rising	150	°C
	Thermal shutdown hysteresis, falling	15	°C

171021801

MagI³C Power Module

WPME-VDLM – Variable Step Down LGA Module



ELECTRICAL SPECIFICATIONS

MIN and MAX limits are valid for the recommended junction temperature range of **-40°C to 125°C**. Typical values represents statistically the utmost probable values at the following conditions: $V_{IN} = 12V$, $T_A = 25°C$, unless otherwise specified.

SYMBOL	PARAMETER	TEST CONDITIONS	MIN ⁽¹⁾	TYP ⁽⁴⁾	MAX ⁽¹⁾	UNIT
Output current						
I_{CL}	Current limit threshold	$T_A = 25°C$	-	4	-	A
Output voltage						
V_{FB}	Reference voltage	$T_A = 25°C$	0.784	0.8	0.816	V
	Reference voltage over temperature		0.776	0.8	0.824	V
I_{FB}	Feedback input bias current	$T_A = 25°C$	-	50	-	nA
V_{OUT}	Line regulation	$V_{IN} = 4V$ to $18V$, $T_A = 25°C$	-	0.4	-	%/V
	Load regulation	$I_{OUT} = 10mA$ to I_{CL} , $T_A = 25°C$	-	0.5	-	%/A
	Output voltage ripple	$V_{OUT} = 3.3V$, $I_{OUT} = 2A$, $T_A = 25°C$, 20MHz BWL	-	15	-	mVpp
Switching frequency						
f_{SW}	Switching frequency	$T_A = 25°C$	0.7	0.85	1	MHz
D_{MAX}	Maximum duty-cycle	$T_A = 25°C$	100	-	-	%
Enable and undervoltage lockout						
V_{UVLO}	V_{IN} undervoltage threshold	V_{IN} increasing	-	2.9	-	V
	V_{IN} undervoltage hysteresis		-	0.25	-	V
V_{ENABLE}	EN threshold trip point	Enable logic high voltage $T_A = 25°C$	1.2	-	-	V
		Enable logic low voltage $T_A = 25°C$	-	-	0.4	V
I_{ENABLE}	EN pin input current	$T_A = 25°C$	-	2	-	μA
Soft-Start						
t_{SS}	Soft-start time		-	1	-	ms
Efficiency						
η	Efficiency	$V_{IN} = 12V$, $V_{OUT} = 3.3V$, $I_{OUT} = 2A$, $T_A = 25°C$	-	88	-	%
		$V_{IN} = 12V$, $V_{OUT} = 5V$, $I_{OUT} = 2A$, $T_A = 25°C$	-	91	-	%
		$V_{IN} = 5V$, $V_{OUT} = 3.3V$, $I_{OUT} = 500mA$, $T_A = 25°C$	-	94	-	%
		$V_{IN} = 5V$, $V_{OUT} = 3.3V$, $I_{OUT} = 2A$, $T_A = 25°C$	-	89	-	%
Input current						
I_Q	Input quiescent current	Switching, no load, $V_{IN} = 12V$, $V_{OUT} = 5V$, $T_A = 25°C$	-	2	-	mA
I_{SD}	Shutdown quiescent input current	EN = 0, $T_A = 25°C$	-	2.1	-	μA

171021801

MagI³C Power Module
WPME-V DLM – Variable Step Down LGA Module

**RELIABILITY**

SYMBOL	PARAMETER	TEST CONDITIONS	MIN ⁽¹⁾	TYP ⁽⁴⁾	MAX ⁽¹⁾	UNIT
MTBF	Mean Time Between Failures	<ul style="list-style-type: none"> - Confidence level 60% - Test temperature: 125°C - Usage temperature: 55°C - Activation energy: 1eV - Test duration: 1000 hours - Sample size: 62342 - Fail: 0 		3.41·10 ¹⁰		h

RoHS, REACH

RoHS directive		Directive 2011/65/EU of the European Parliament and the Council of June 8th, 2011 on the restriction of the use of certain hazardous substances in electrical and electronic equipment.
REACH directive		Directive 1907/2006/EU of the European Parliament and the Council of June 1st, 2007 regarding the Registration, Evaluation, Authorisation and Restriction of Chemicals (REACH).

PACKAGE SPECIFICATIONS

MOLD COMPOUND			WEIGHT
Part Number	Material	Certificate Number	
171021801	EME-E670E	E41429	0.8 g

NOTES

- (1) Min and Max limits are 100% production tested at 25°C. Limits over the operating temperature range are guaranteed through correlation using Statistical Quality Control (SQC) methods.
- (2) The human body model is a 100pF capacitor discharged through a 1.5 kΩ resistor into each pin. Test method is per JESD-22-114.
- (3) JEDEC J-STD020
- (4) Typical numbers are valid at 25°C ambient temperature and represent statistically the utmost probability assuming the Gaussian distribution.
- (5) Depending on heat sink design, number of PCB layers, copper thickness and air flow.
- (6) Measured on a 8cm x 8cm four layer PCB 35µm copper, thirty-six 10mil (254µm) thermal vias, no air flow.

171021801

Mag³C Power Module
WPME-V DLM – Variable Step Down LGA Module



TYPICAL PERFORMANCE CURVES

If not otherwise specified, the following conditions apply: $V_{IN} = 12V$, $T_{AMB} = 25^{\circ}C$.

RADIATED AND CONDUCTED EMISSIONS

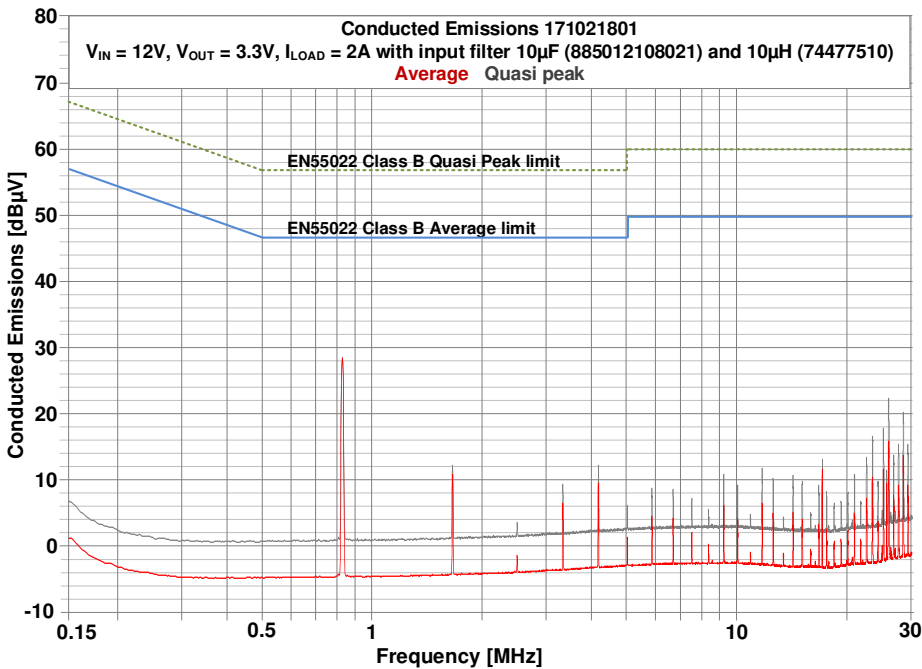
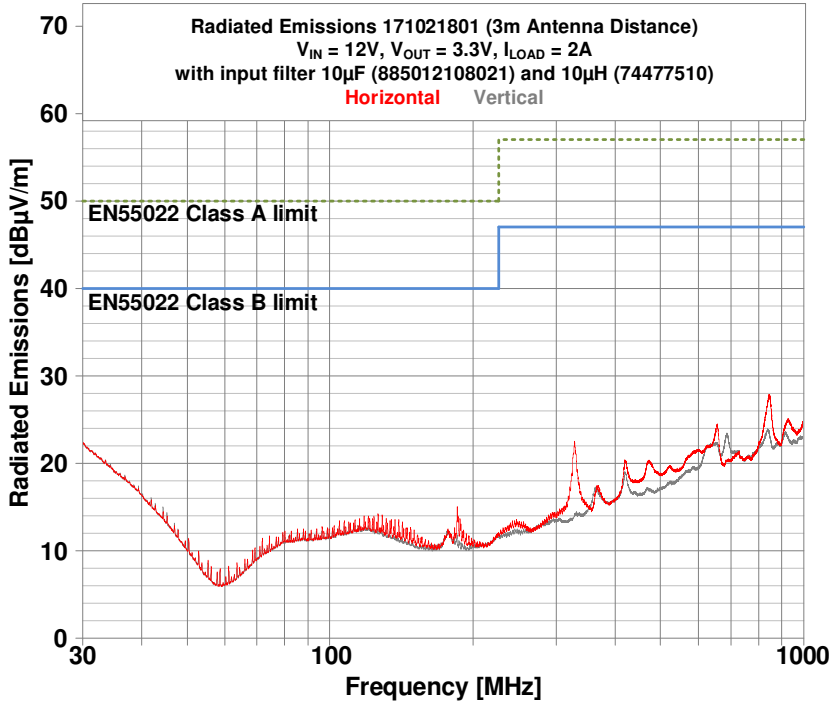

171021801

MagI³C Power Module
WPME-V DLM – Variable Step Down LGA Module



EFFICIENCY

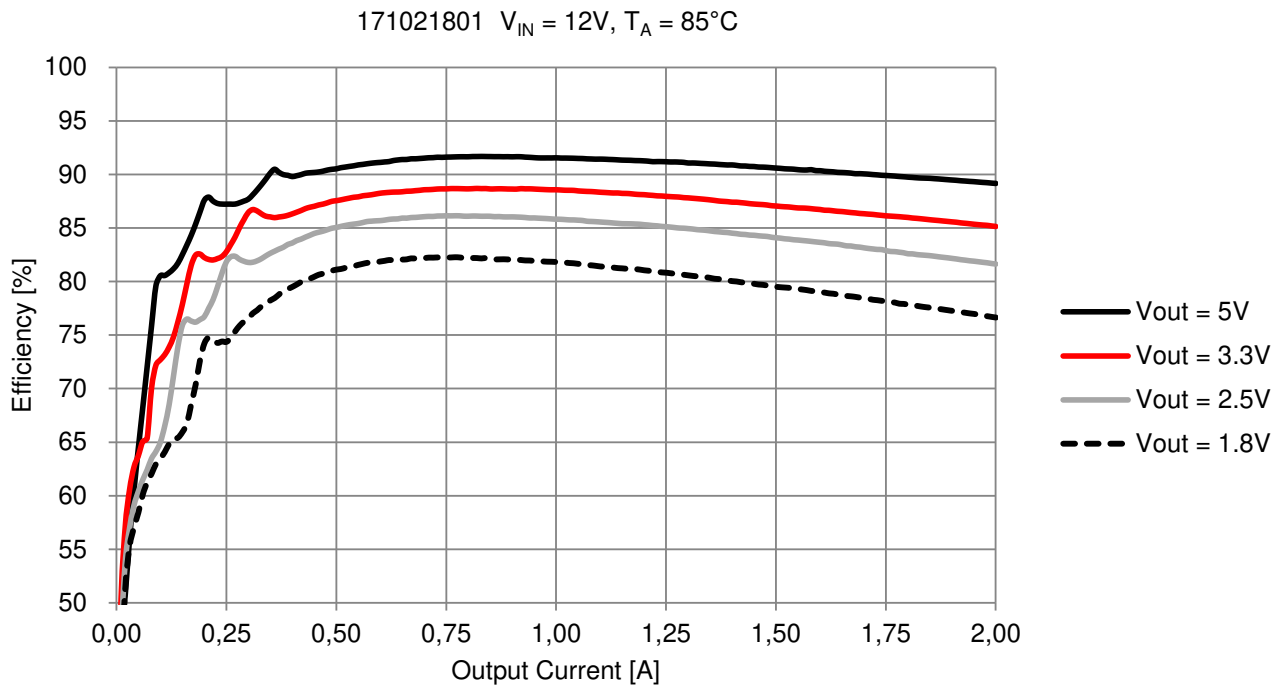
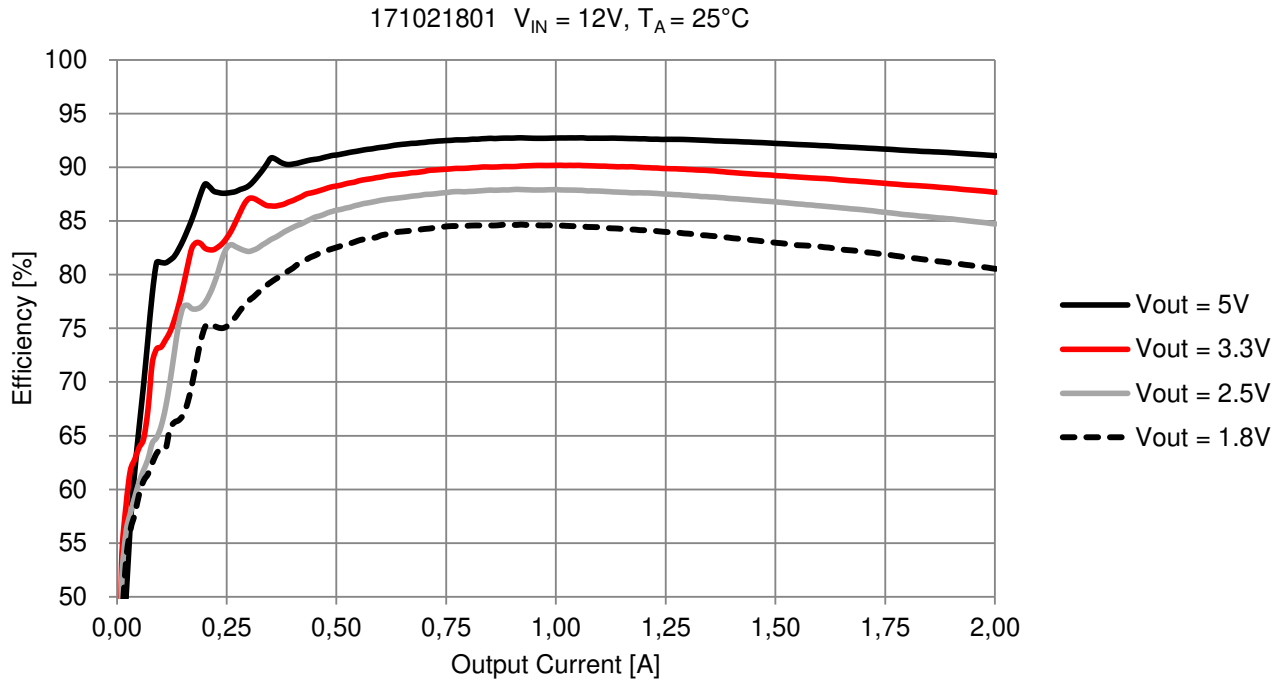

171021801

MagI³C Power Module
WPME-VDLM – Variable Step Down LGA Module



EFFICIENCY

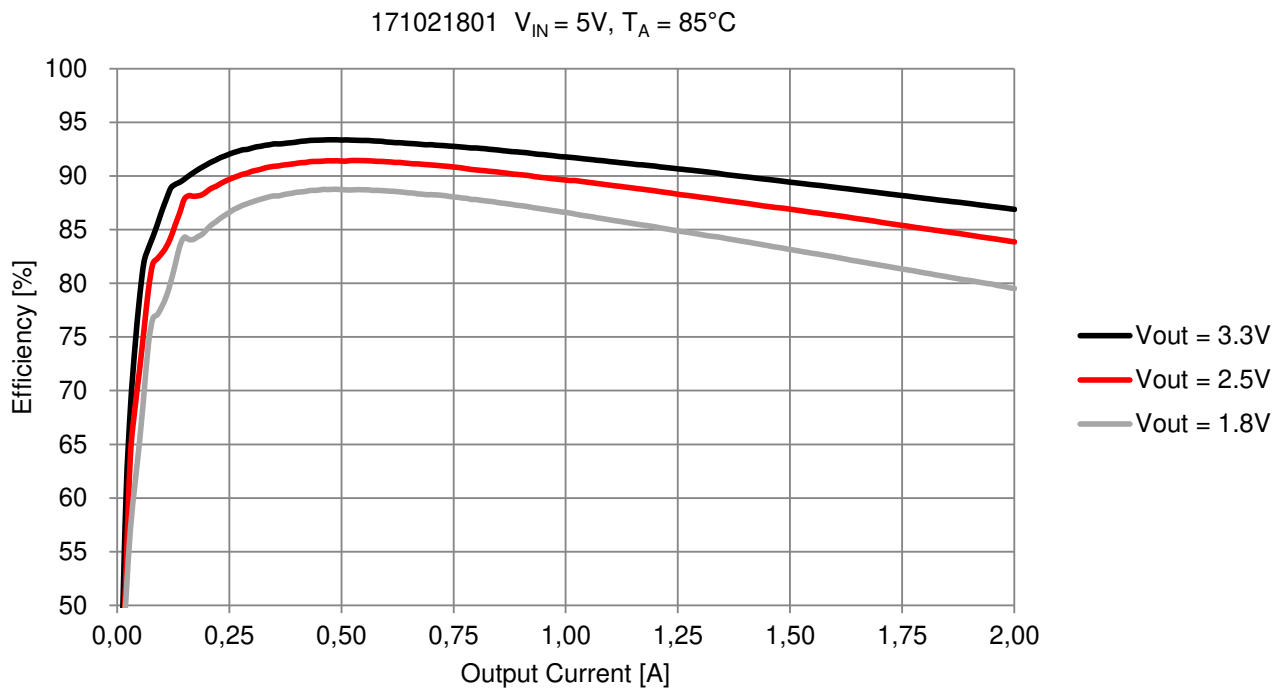
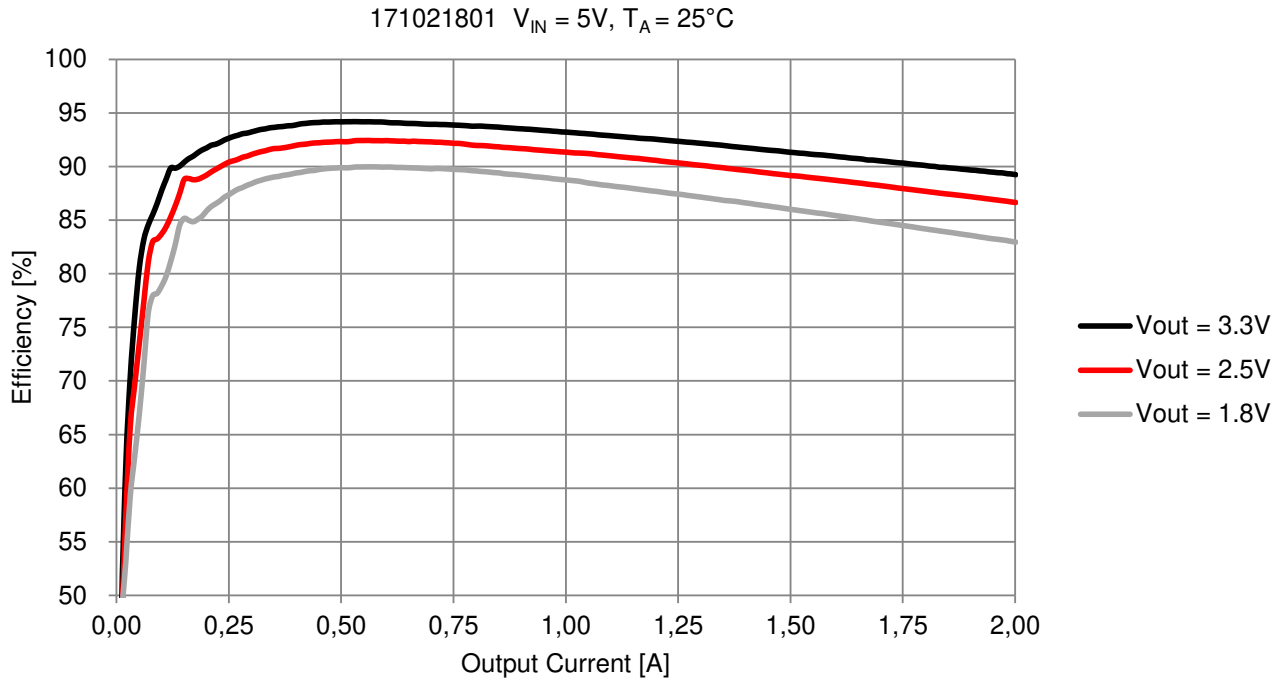

171021801

MagI³C Power Module
WPME-VDLM – Variable Step Down LGA Module



POWER DISSIPATION

171021801 $V_{IN} = 12V$, $T_A = 25^\circ C$

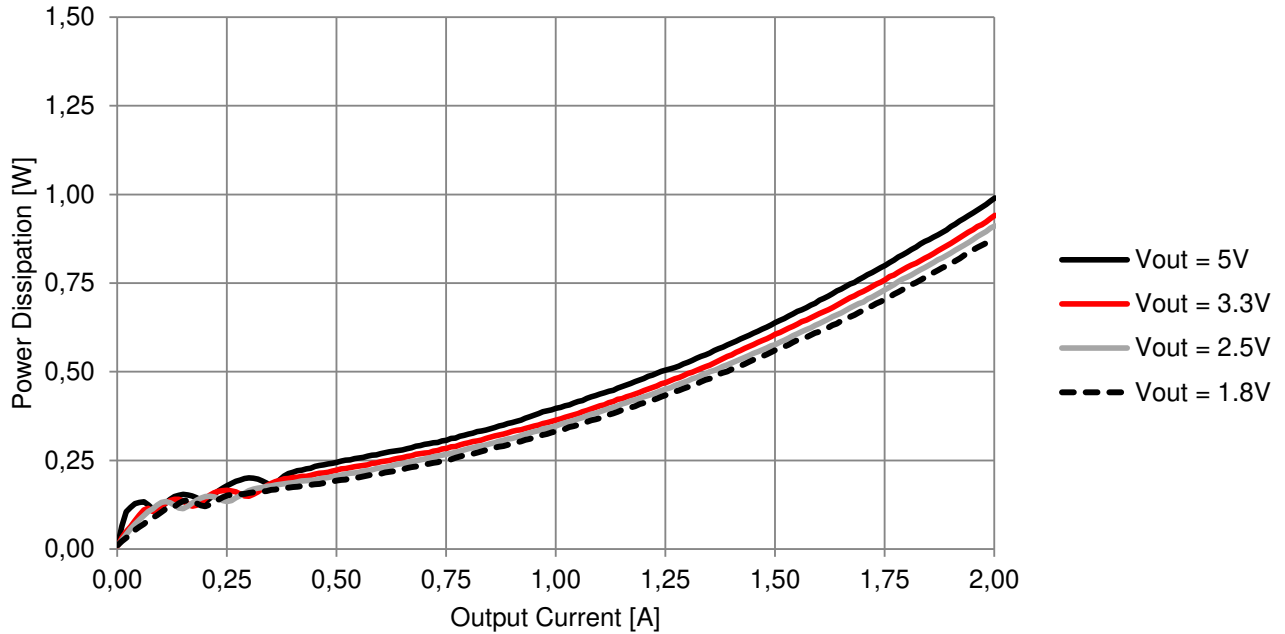

171021801 $V_{IN} = 12V$, $T_A = 85^\circ C$

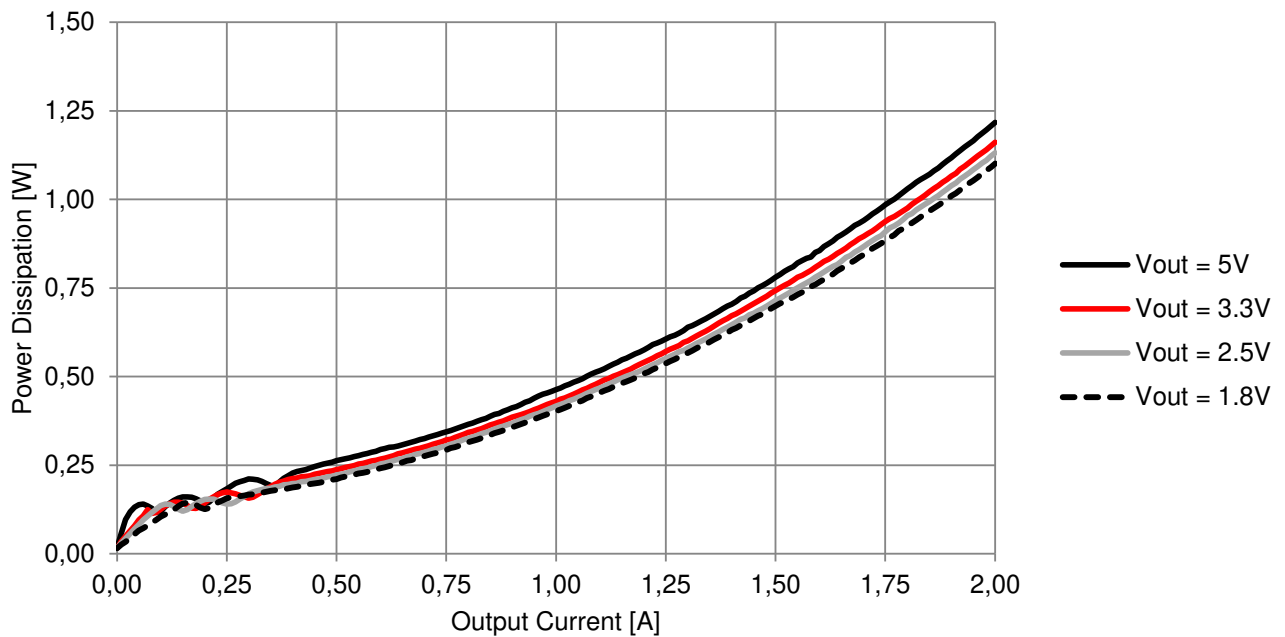

171021801

MagI³C Power Module
WPME-V DLM – Variable Step Down LGA Module



POWER DISSIPATION

171021801 $V_{IN} = 5V$, $T_A = 25^\circ C$

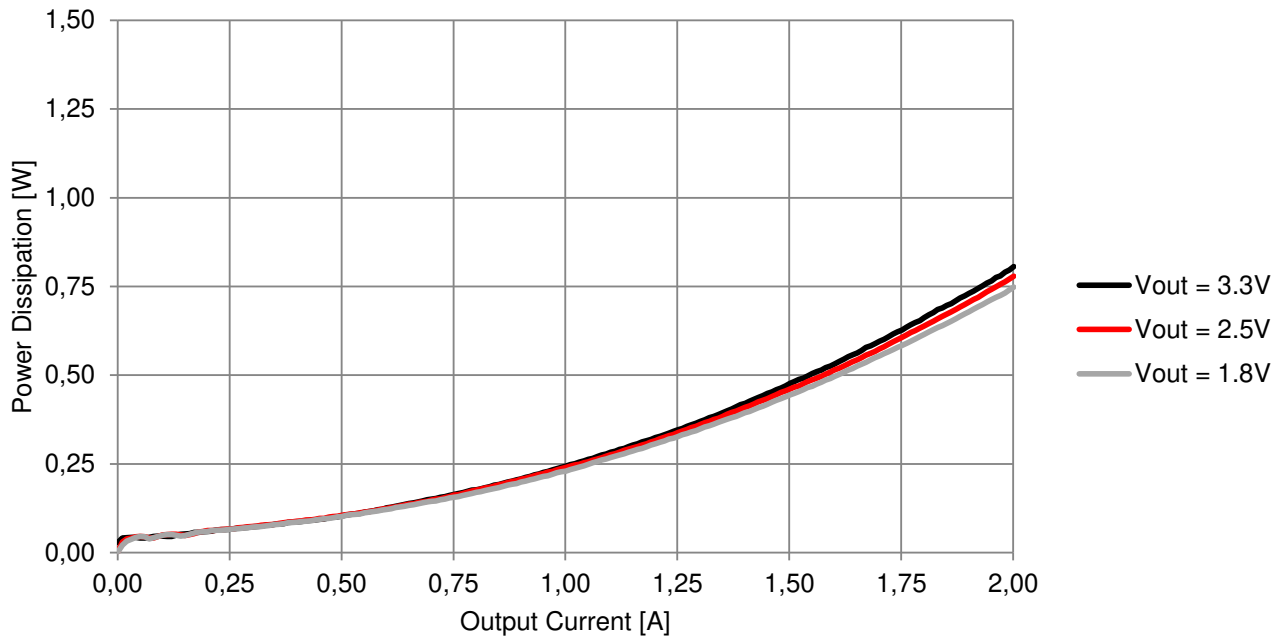

171021801 $V_{IN} = 5V$, $T_A = 85^\circ C$

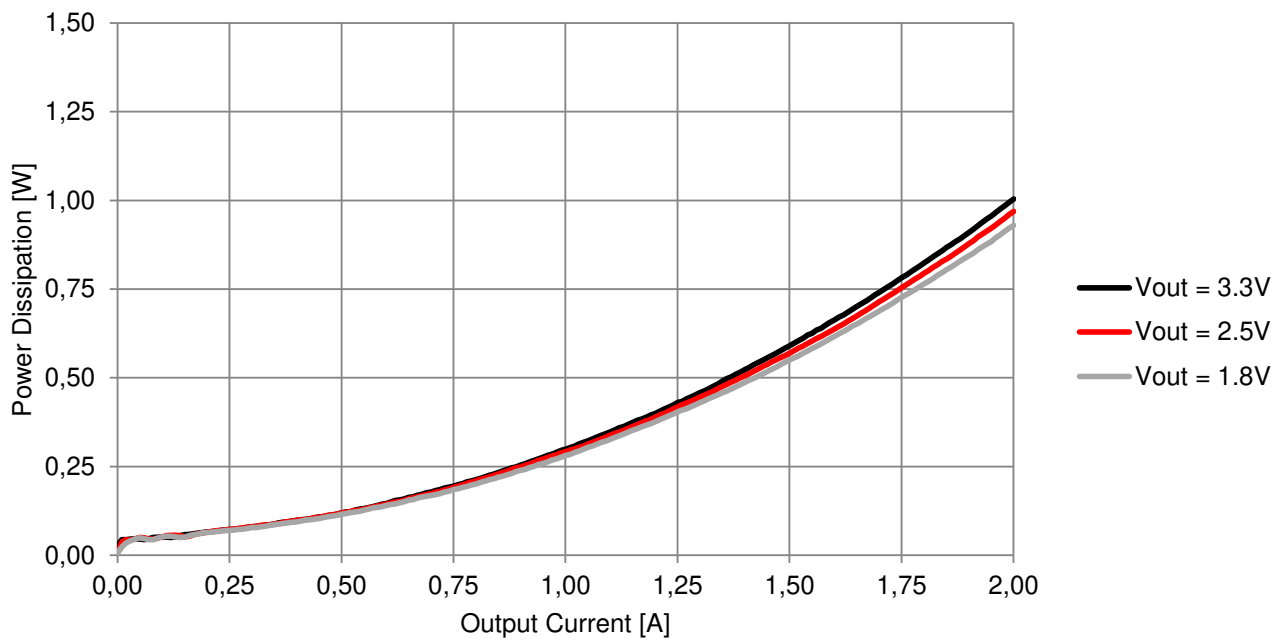

171021801

MagI³C Power Module
WPME-VDLM – Variable Step Down LGA Module



OUTPUT POWER DERATING

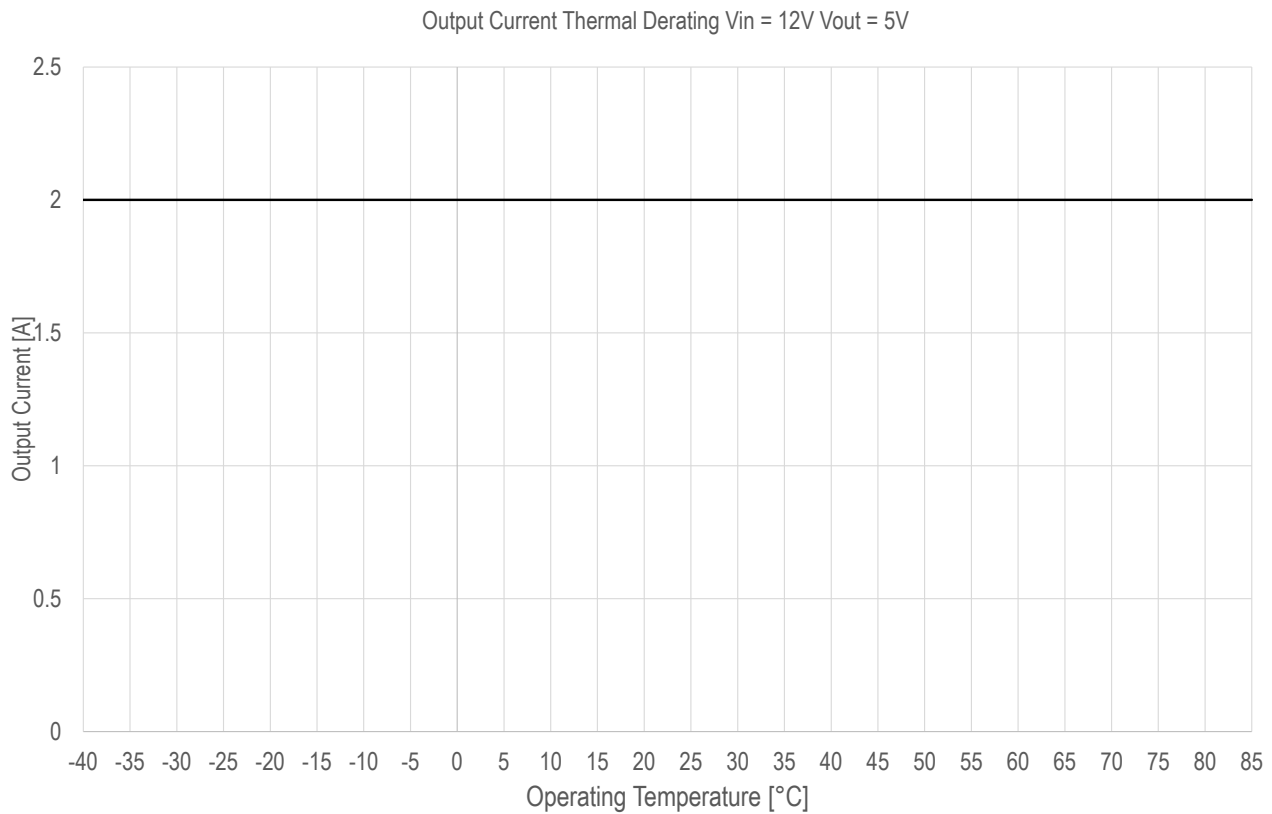

The ambient temperature and the power limits of the derating curve represent the operation at the max junction temperature specified in the [“Operating Conditions”](#) section on page 4.

171021801

MagI³C Power Module
WPME-VDLM – Variable Step Down LGA Module



LINE AND LOAD REGULATION

171021801 Line Regulation $V_{OUT} = 3.3V$, $I_{OUT} = 2A$, $T_A = 25^\circ C$

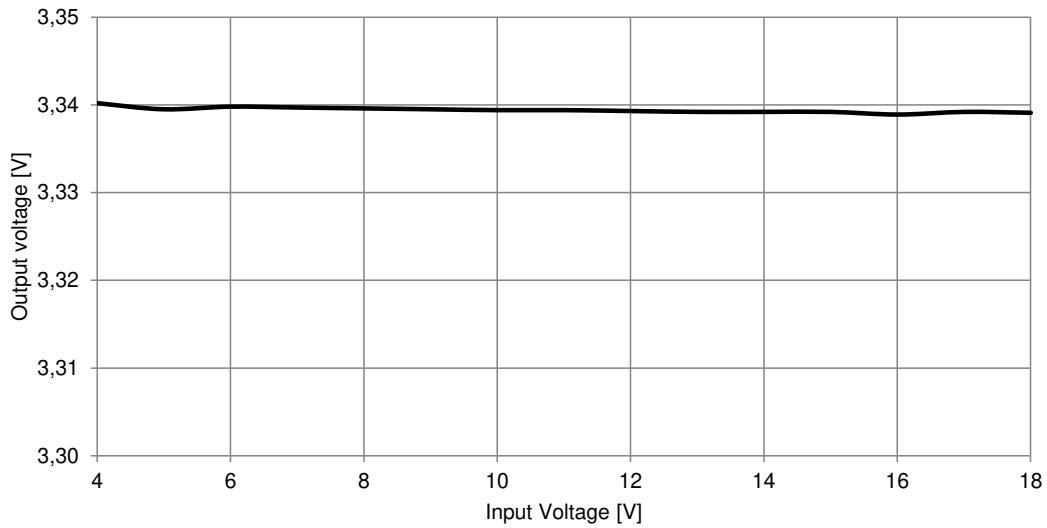

171021801 Load Regulation $V_{IN} = 12V$, $V_{OUT} = 5V$, $T_A = 25^\circ C$

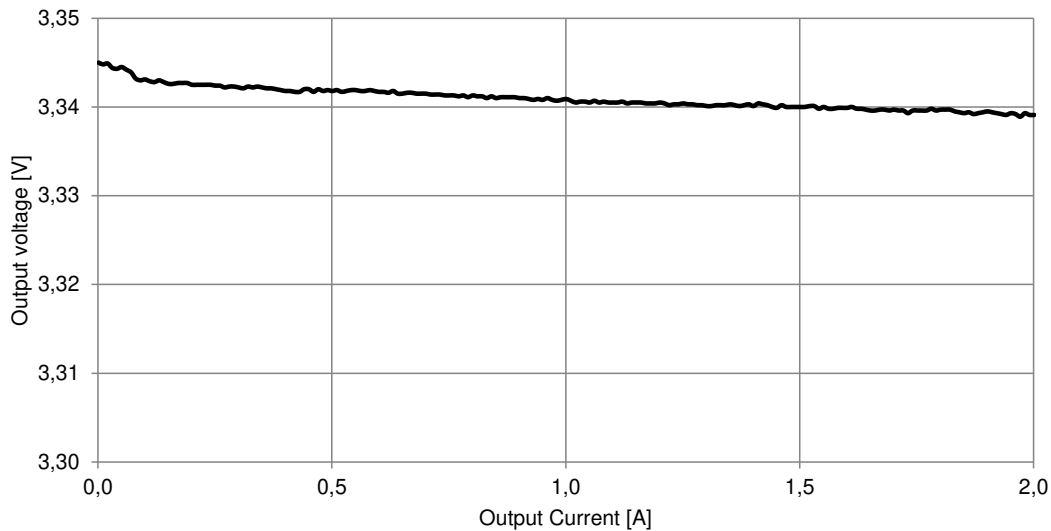

171021801

MagI³C Power Module
WPME-VDLM – Variable Step Down LGA Module



BLOCK DIAGRAM

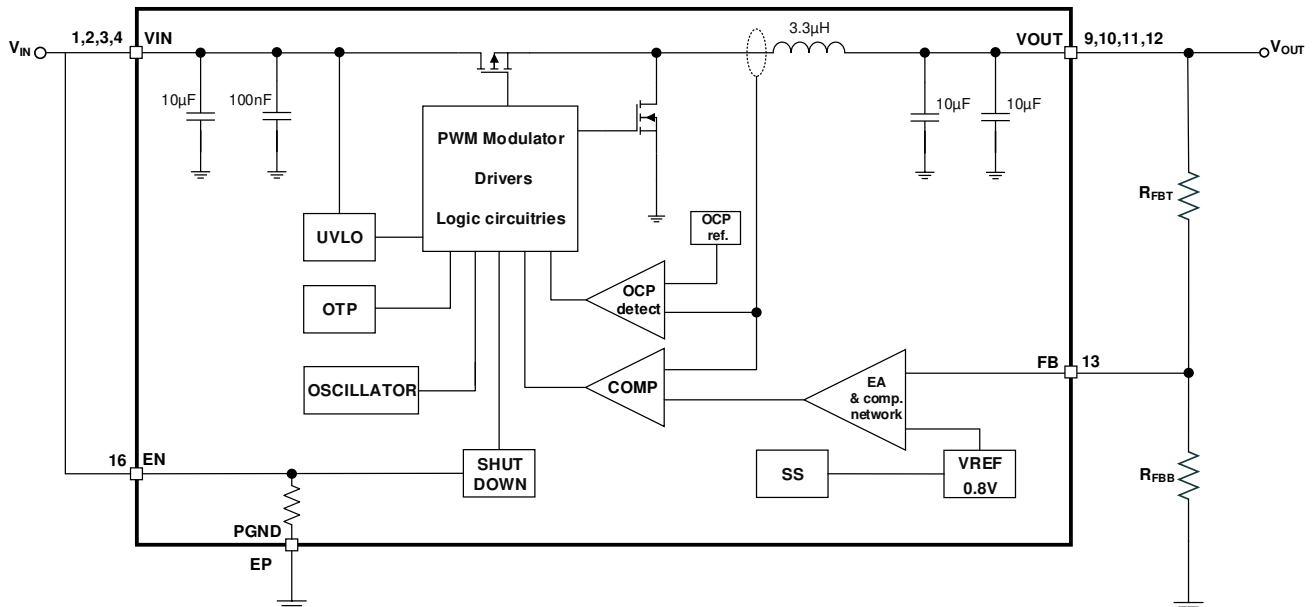

CIRCUIT DESCRIPTION

The MagI³C Power Module series 171021801 is based on a synchronous step down regulator with integrated MOSFETs, power inductor and both the input and the output capacitors. The control scheme is based on a peak Current Mode (CM) regulation loop.

The V_{OUT} of the regulator is divided by the feedback resistor divider and fed into the FB pin. The error amplifier compares this signal with the internal 0.8V reference. The error signal is amplified and controls the on-time of a fixed frequency pulse width generator. This signal drives the power MOSFETs.

The Current Mode architecture features a constant frequency during load steps. Only the on-time is modulated. It is internally compensated and requires no additional external compensation network.

This architecture supports fast transient response and very small output ripple values (less than 15mV) are achieved only relying on the integrated output capacitors.

171021801

MagI³C Power Module
WPME-VDLM – Variable Step Down LGA Module

DESIGN FLOW

The design flow for 171021801 consist of a single step: setting the output voltage trough the external resistor divider. External input and output capacitors are not necessary

Essential Step

1. Set the output voltage

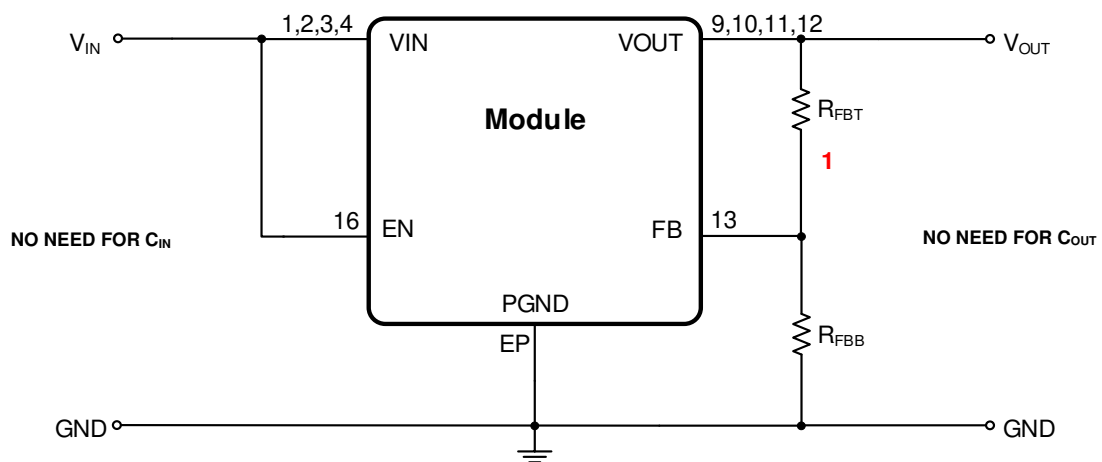
Step 1 Set the output voltage (V_{OUT})

The output voltage is determined by a divider of two resistors connected between V_{OUT} and ground. The midpoint of the divider is connected to the FB input. The output voltage adjustment range is from 0.8V to 17V.

The ratio of the feedback resistors for the desired output voltage is:

$$\frac{R_{FBT}}{R_{FBB}} = \left(\frac{V_{OUT}}{V_{FB}} \right) - 1 \quad (1)$$

A table of values for R_{FBT} and R_{FBB} , is included in the “[TYPICAL SCHEMATIC](#)” section (page 35).

171021801

MagI³C Power Module

WPME-VDLM – Variable Step Down LGA Module



Optional Steps

2. Add external input capacitors (in case an input voltage ripple reduction is required)
3. Add external output capacitors (in case an output voltage ripple reduction or output voltage under- or overshoot reduction load transient are required)

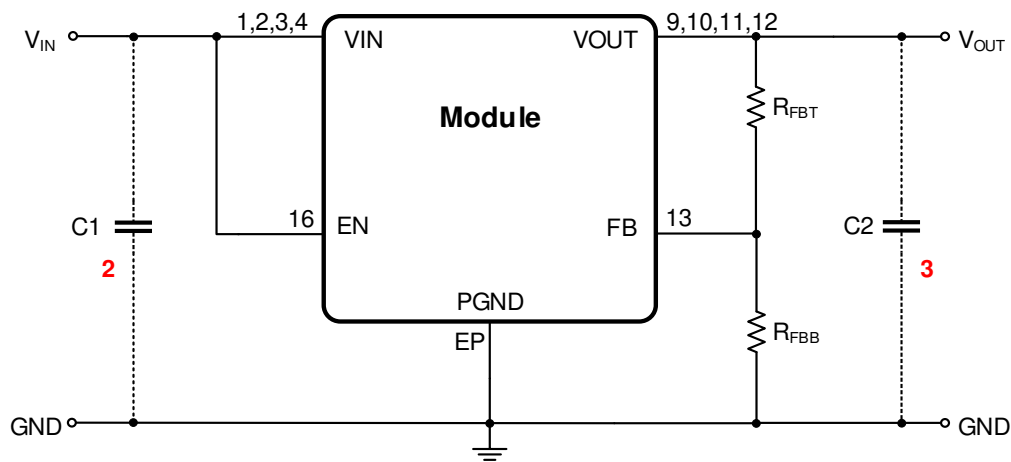

C1 and C2 normally not necessary

171021801

MagI³C Power Module

WPME-VDLM – Variable Step Down LGA Module



Step 2 Select the input capacitor (C_{IN})

The 171021801 integrates already a 10µF MLCC as input capacitor in parallel with a 100nF MLCC. These capacitors are enough to fulfil the targeted steady state and transient response under all operating conditions.

The resulting input voltage ripple with the internal input capacitors (V_{IN ripple,INT}) is shown in the figure below:

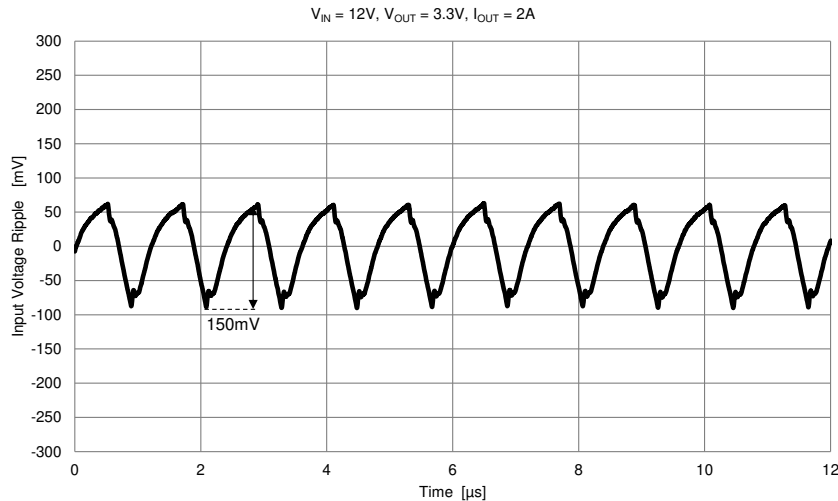

If the application has more demanding requirements in terms of input voltage ripple, an external input capacitor can be placed.

The input capacitor selection is generally based on different requirements. The first criterion is the input current ripple. Worst case input current ripple rating is dictated by the equation:

$$I_{C_{IN}RMS} \approx \frac{1}{2} \cdot I_{OUT} \cdot \sqrt{\frac{D}{1-D}} \quad (2) \quad \text{where } D \approx \frac{V_{OUT}}{V_{IN}}$$

As a point of reference, the worst case current ripple will occur when the module is presented with full load current and when V_{IN} = 2 x V_{OUT}.

The second criterion is the input voltage ripple. If the system design requires a certain minimum value of peak-to-peak input voltage ripple then the following equation may be used:

$$C_{IN} \geq \frac{I_{OUT} \cdot D \cdot (1-D)}{f_{SW(CCM)} \cdot (V_{IN \text{ ripple}} - ESR \cdot I_{OUT} \cdot D)} \quad (3)$$

The value of the additional external input capacitor (C_{IN,EXT}) in case a further reduction of the input voltage ripple is required can be calculated with the following equation:

$$C_{IN,EXT} \geq \frac{I_{OUT} \cdot D \cdot (1-D)}{f_{SW(CCM)} \cdot (V_{IN \text{ ripple}} - ESR \cdot I_{OUT} \cdot D)} - C_{IN,INT} \quad (4)$$

where the V_{IN ripple} is the required input voltage ripple and C_{IN,INT} represents the total integrated input capacitance (in this case 10µF+100nF). It is always strongly recommended to pay attention to the voltage and temperature derating of the selected capacitor.

171021801

MagI³C Power Module

WPME-VDLM – Variable Step Down LGA Module



Example

$V_{IN} = 12V$, $V_{OUT} = 3.3V$, $I_{OUT} = 2A$, $V_{IN\ ripple} \leq 90mV$.

The duty cycle is theoretically defined as the ratio between the output and the input voltage. Actually, a correct estimate of the duty cycle should consider also the efficiency, as shown by the following formula:

$$D = \frac{V_{OUT}}{V_{IN} \cdot \eta} \quad (5)$$

where η represents the efficiency and its value under the specified conditions can be read on the diagram on page 8 (88%).

The equation (4) can be used to calculate the additional external capacitor to achieve the target input voltage ripple. The actual value of the integrated capacitance ($C_{IN,INT}$) can be estimated by using capacitance derating diagram of the internal capacitor shown below.

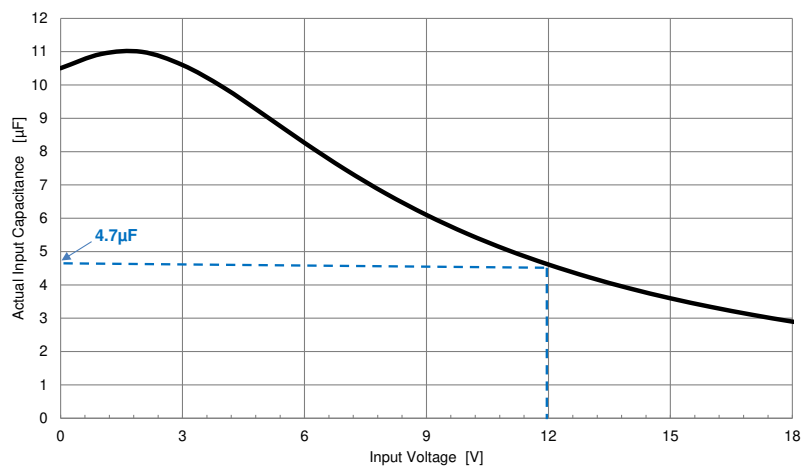

From the diagram above, the actual capacitance value of $4.7\mu F$ can be read.

171021801

MagI³C Power Module

WPME-VDLM – Variable Step Down LGA Module



Now equation (4) can be finally used to calculate the required external input capacitor to fulfil the input voltage ripple requirements, assuming ESR = 5mΩ:

$$C_{IN,EXT} = \frac{2A \cdot 0.312 \cdot (1 - 0.312)}{850kHz \cdot (0.09V - 0.005\Omega \cdot 2A \cdot 0.312)} - 4.7\mu F = 1.1\mu F$$

Some margin from the calculated $C_{IN,ext}$ value is recommended in order to take into account:

- Approximations within the equations to calculate C_{IN} ;
- Tolerances and variations of some components and parameters involved in those equations (e.g. f_{sw} , ESR, etc.)
- Derating of the capacitors with DC applied voltage and temperature

A 4.7μF MLCC (Würth Elektronik 885012109012) is selected as $C_{IN,EXT}$. The resulting input voltage ripple using the additional input capacitor is depicted by the figure below.

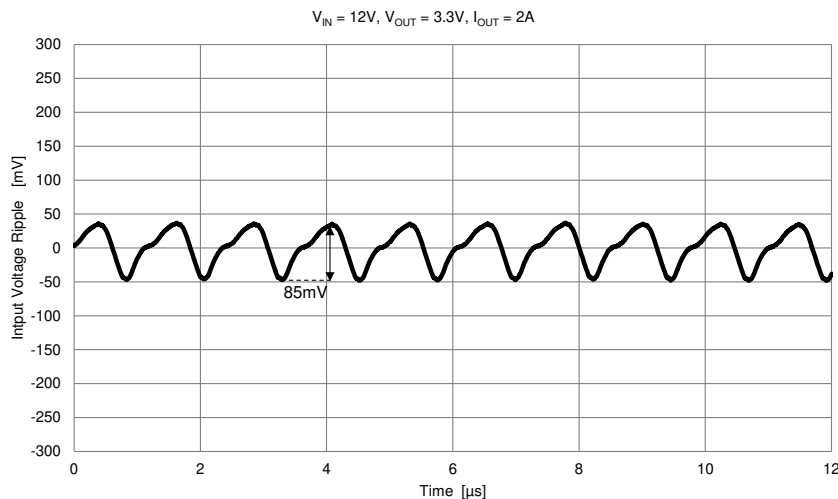

171021801

MagI³C Power Module

WPME-VDLM – Variable Step Down LGA Module



Step 3 Select output capacitor (C_{OUT})

The output capacitance determines the performance in terms of output voltage ripple as well as load transient response. The 171021801 integrates already two MLCC of 10μF as output capacitors, which are enough to operate under all conditions. Therefore no external additional output capacitor is necessary.

Output voltage ripple

The output capacitor should be selected in order to minimize the output voltage ripple and provide a stable voltage at the output. In general, under steady state conditions the output voltage ripple observed at the output can be defined as:

$$V_{OUT\text{ripple}} = \Delta I_L \cdot ESR + \Delta I_L \cdot \frac{1}{8 \cdot f_{SW} \cdot C_{OUT}} \quad (6)$$

where ΔI_L is the inductor current ripple, calculated with the following equation:

$$\Delta I_L = \frac{V_{OUT} \cdot (V_{IN} - V_{OUT})}{f_{SW} \cdot L \cdot V_{IN}} \quad (7)$$

The output voltage ripple achievable with the integrated output capacitors only ($V_{OUT\text{ripple, int}}$) is around 15mV, as shown by the figure below.

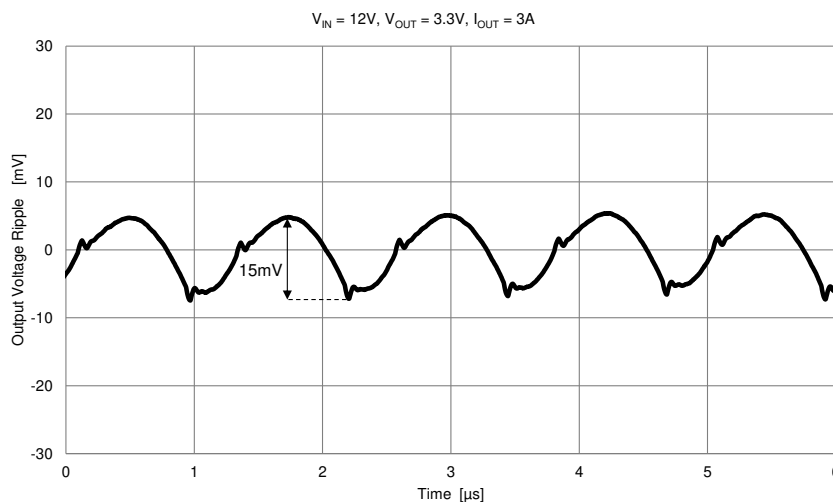

In case the application has more demanding requirements in terms of output voltage ripple, additional external capacitors should be used. The value of the external additional capacitance ($C_{OUT,EXT}$) can be calculated using the following equation:

$$C_{OUT,EXT} \geq \frac{\Delta I_L}{8 \cdot (V_{OUT\text{ripple}} - ESR \cdot \Delta I_L) \cdot f_{SW}} - C_{OUT,INT} \quad (8)$$

where $V_{OUT\text{ripple}}$ represents the target output voltage ripple whereas $C_{OUT,INT}$ indicates the total amount of the integrated capacitance (20μF).

171021801

MagI³C Power Module WPME-VDLM – Variable Step Down LGA Module



Example

$V_{IN} = 12V$, $V_{OUT} = 3.3V$, $I_{OUT} = 2A$ (this parameter does not influence the output voltage ripple).

First of all the actual value of the integrated output capacitance must be estimated, using the derating curve below:

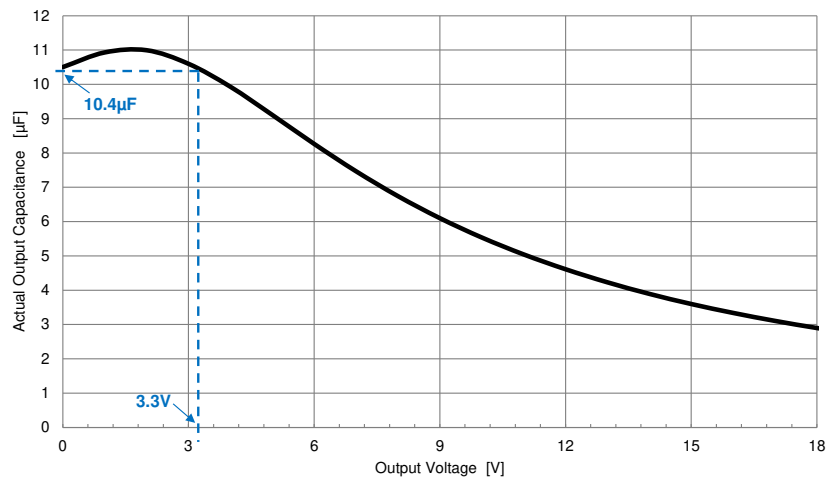

At $V_{OUT} = 3.3V$ the value of the output capacitance is not reduced due to the voltage, it is instead slightly higher. Nevertheless, a total value of $20\mu F$ can be considered for $C_{OUT,INT}$.

Assuming that the application requires an output voltage ripple less than $10mV$, the additional external capacitance should be at least $2\mu F$, according to equation (8):

$$C_{OUT,EXT} \geq \frac{0.853A}{8 \cdot (0.01V - 0.005\Omega \cdot 0.853A) \cdot 0.85 \text{ MHz}} - 20\mu F = 2\mu F$$

where a value of ESR of $5m\Omega$ is assumed and $\Delta I_L = 0.853A$ is the inductor current ripple calculated with the equation (7). Some margin from the calculated $C_{OUT,ext}$ value is recommended in order to take into account:

- Approximations within the equations to calculate C_{OUT} ;
- Tolerances and variations of some components and parameters involved in those equations (e.g. f_{sw} , ESR, etc.);
- Derating of the capacitors with DC applied voltage and temperature

171021801

MagI³C Power Module
WPME-VDLM – Variable Step Down LGA Module

An additional external capacitor of 10 μ F (Würth Elektronik 885012208069) has been selected as the best performing. The resulting output voltage ripple is shown in the figure below.

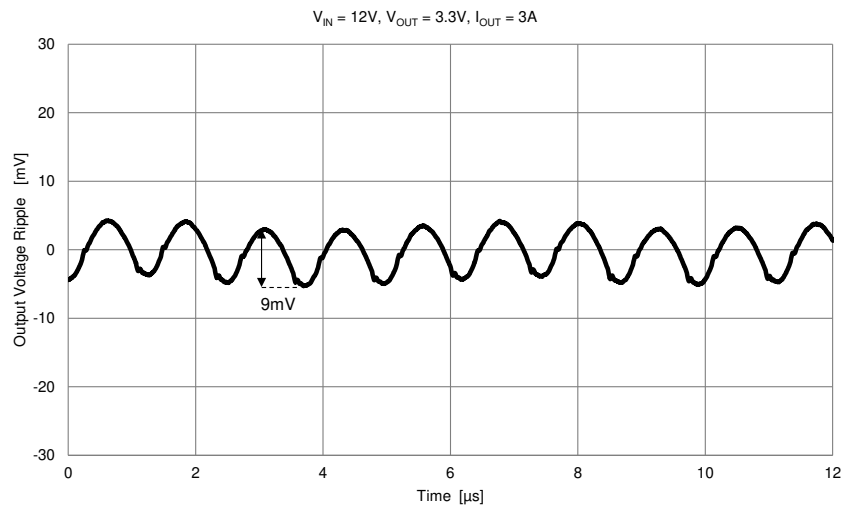

171021801

MagI³C Power Module WPME-VDLM – Variable Step Down LGA Module



Load transient response

The output voltage is also affected by load transients (see picture below).

When the output current transitions from a low to a high value, the voltage at the output capacitor (V_{OUT}) drops. This involves two contributing factors. One is caused by the voltage drop across the ESR (V_{ESR}) and depends on the slope of the rising edge of the current step (t_{rise}). For low ESR values and small load current transients, this is often negligible. It can be calculated as follows:

$$V_{ESR} = ESR \cdot \Delta I_{OUT} \quad (9)$$

where ΔI_{OUT} is the load step, as shown in the picture below (simplified: no voltage ripple is shown).

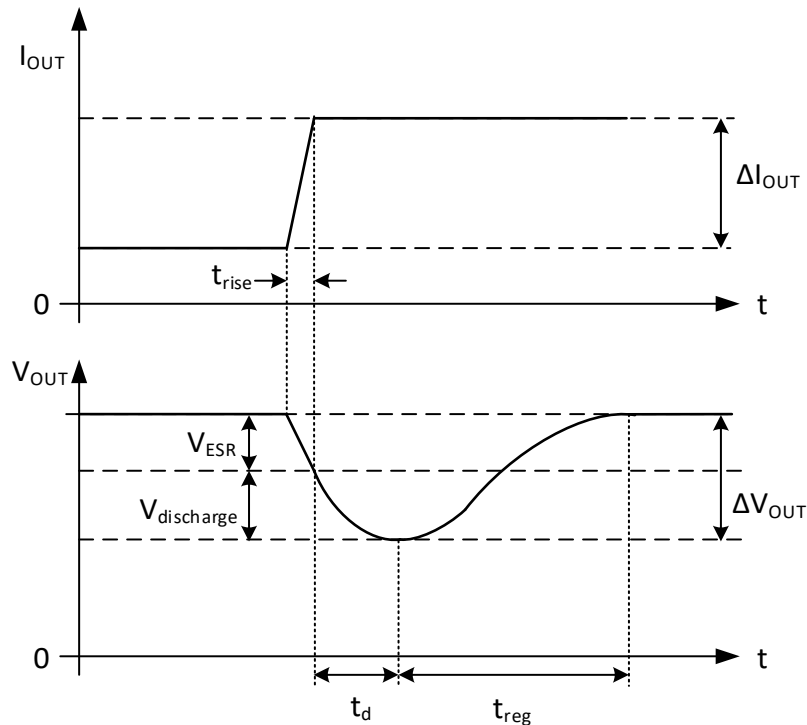

The second contributing factor is the voltage drop due to discharge of the output capacitor, which can be estimated as:

$$V_{discharge} = \frac{\Delta I_{OUT} \cdot t_d}{2 \cdot C_{OUT}} \quad (10)$$

In a current mode architecture the t_d is strictly related to the bandwidth of the regulation loop and influenced by the C_{OUT} (increasing C_{OUT} , the t_d increases as well).

171021801

MagI³C Power Module
WPME-VDLM – Variable Step Down LGA Module



The figures below show the load transient response achieved with the integrated capacitors only.

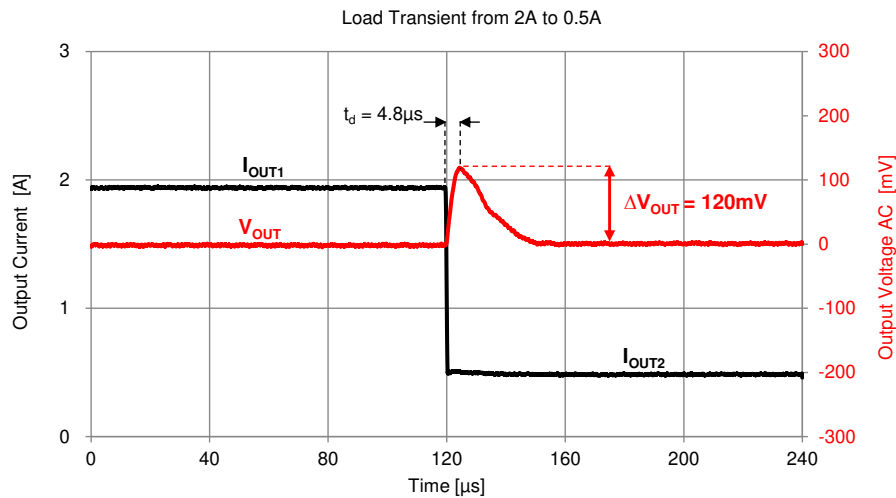
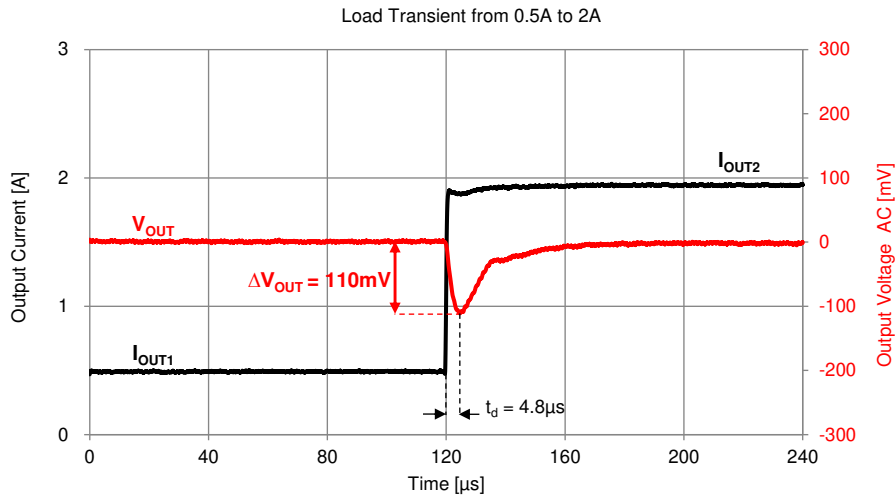

If the application demands a lower undershoot or overshoot, an additional external capacitance is necessary. In order to choose the value of the external output capacitor $C_{OUT,EXT}$, the following steps should be utilized:

1. Measure t_d .
2. Calculate the appropriate value of $C_{OUT,EXT}$ for the maximum voltage drop $V_{discharge}$ allowed at a defined load step, using the following equation (11), derived from equation (10).
3. As mentioned above, changing C_{OUT} affects also t_d . Therefore, a new measurement should be performed and, if necessary, the step 1 and 2 should be repeated (it is an iterative process and few steps could be required).

$$C_{OUT,EXT} \geq \frac{\Delta I_{OUT} \cdot t_d}{2 \cdot V_{discharge}} - C_{OUT,INT} \tag{11}$$

171021801

MagI³C Power Module

WPME-VDLM – Variable Step Down LGA Module



Example

The following application conditions are used as an example to show how to calculate a suitable $C_{OUT,EXT}$ value, in case the application requirements demand a further reduction of the overshoot and undershoot of the output voltage after the load transient.

- $V_{IN} = 12V$
- $V_{OUT} = 3.3V$
- load transient from 0.5A to 2A and vice versa ($\Delta I_{OUT} = 1.5A$)
- max allowed undershoot or overshoot $\Delta V_{OUT} = 100mV$

Using [equation \(11\)](#), the value of the additional capacitor $C_{OUT,EXT}$ can be calculated. As explained above, some iterations are necessary in order to find the most suitable value because any change in the output capacitance affects t_d , which is in turn involved in determining the value of $C_{OUT,EXT}$, and so on.

A combination of two MLCC of 22 μ F (Würth Elektronik 885012109014) are selected.

The load transients with the selected $C_{OUT,EXT}$ can be tested using the setup depicted below:

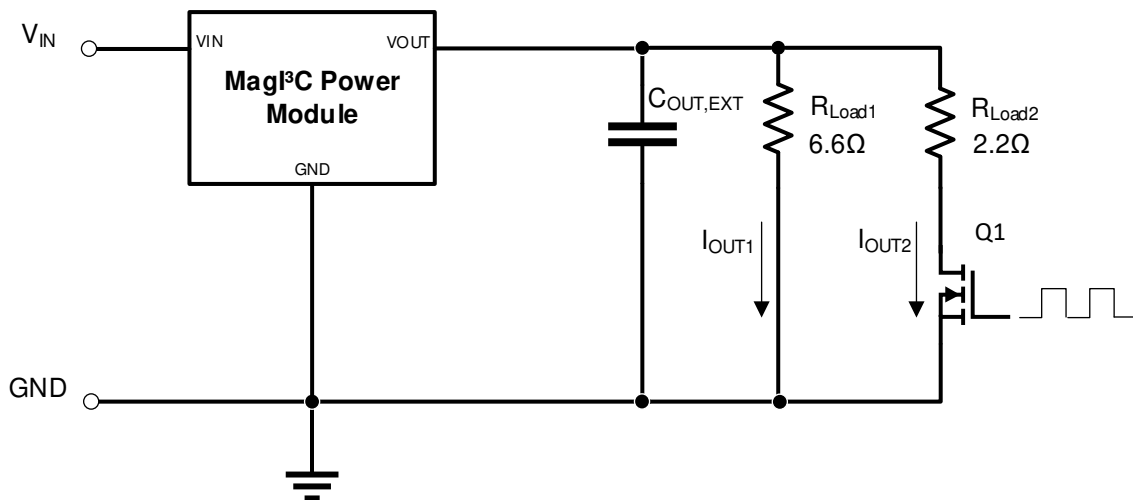

171021801

MagI³C Power Module
WPME-VDLM – Variable Step Down LGA Module



The load transient response results with the additional external $C_{OUT,EXT} = 2 \times 22\mu F$ are shown below. For both the positive (from 0.5A to 2A) and negative (from 2A to 0.5A) load transients the undershoot and the overshoot respectively are within the target defined for this example.

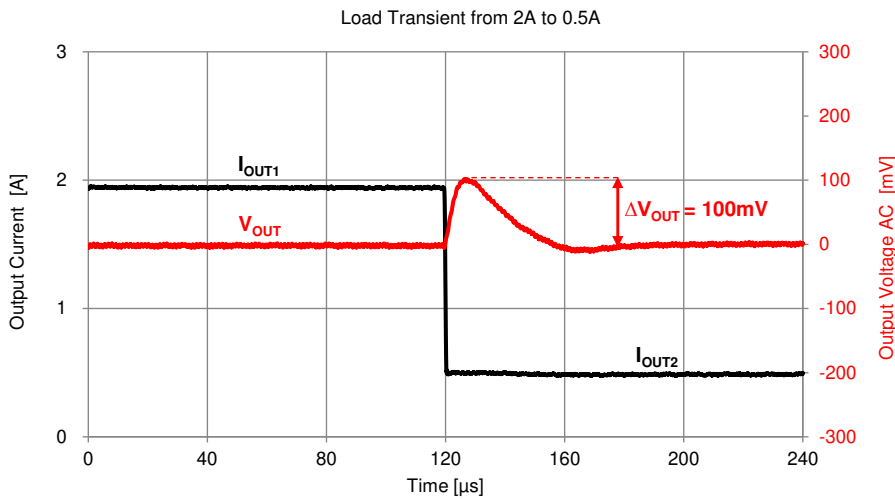
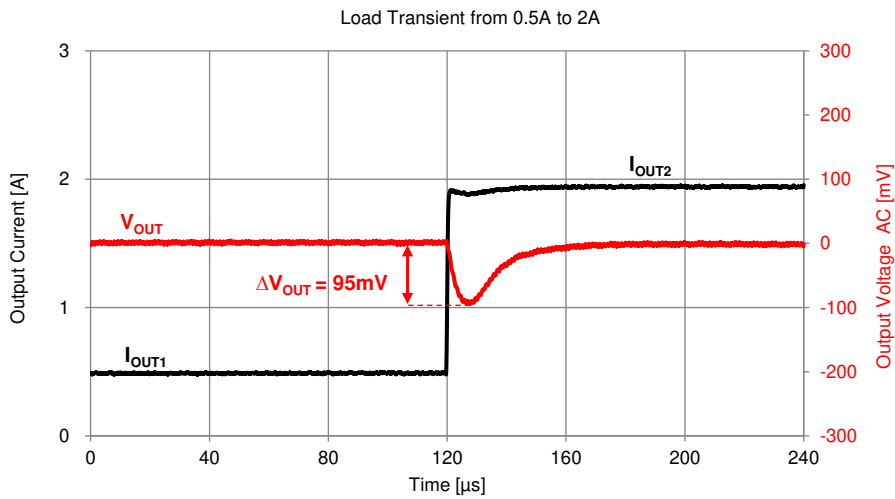

171021801

MagI³C Power Module WPME-VDLM – Variable Step Down LGA Module



ENABLE

The enable function allows the device to be put into shutdown mode. Driving the EN pin with a voltage lower than 0.4V disables the device and reduces dramatically the input current consumption (typ 2.1µA), while driving the EN pin with a voltage higher than 1.2V enables the device. An internal pull-down resistor ensures that the device is disabled also when the EN pin is left floating. The EN pin is also VIN compatible.

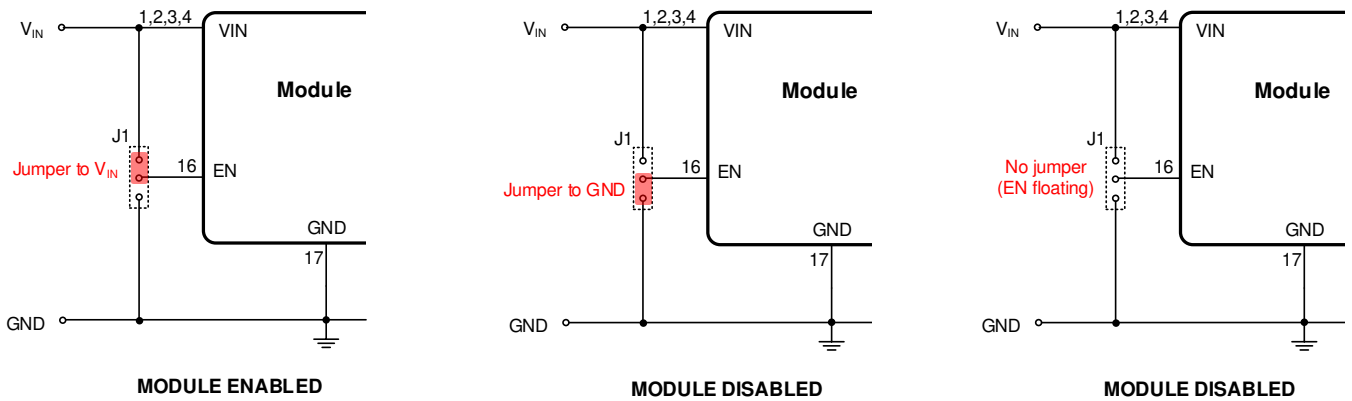

SOFT-START

The 171021801 implements an internal soft-start (see figure below) in order to limit the inrush current and avoid output voltage overshoot during start-up. The soft-start is implemented by ramping the reference voltage (non-inverting input of the error amplifier) from 0V to 0.8V in around 1ms (typical duration of the soft-start).

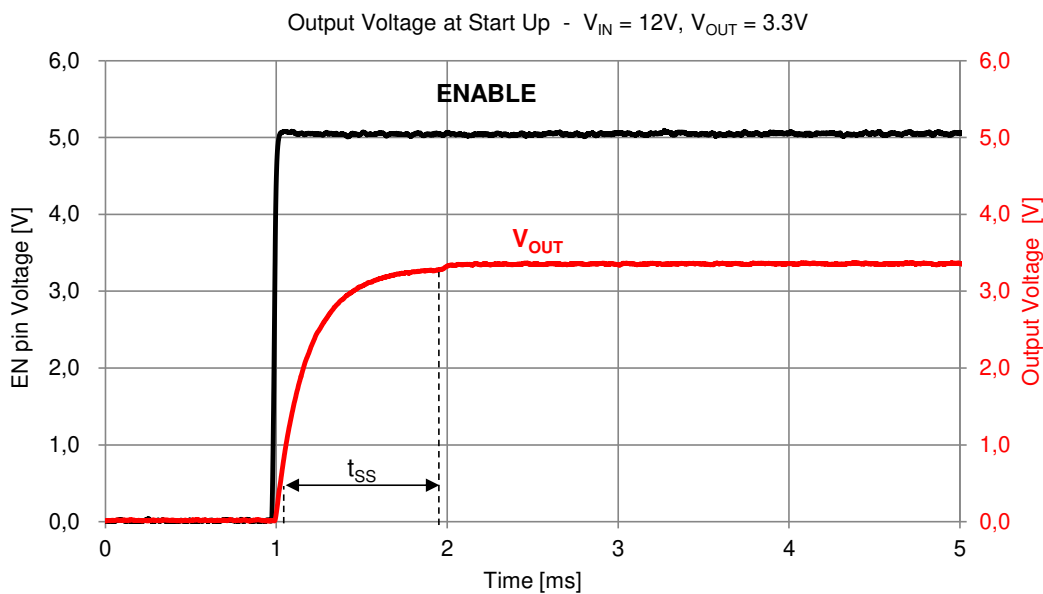

171021801

MagI³C Power Module
WPME-VDLM – Variable Step Down LGA Module



LIGHT LOAD OPERATION

Under light load operation, the device switch from in Continuous Conduction Mode (CCM) to Discontinuous Conduction Mode (DCM). The load current where the transition between DCM and CCM takes place can be estimated using the following formula:

$$I_{OUT(DCM)} = \frac{V_{OUT} \cdot \left(1 - \frac{V_{OUT}}{V_{IN}}\right)}{2 \cdot f_{SW} \cdot L} \tag{12}$$

The figures below show the device working in CCM and DCM.

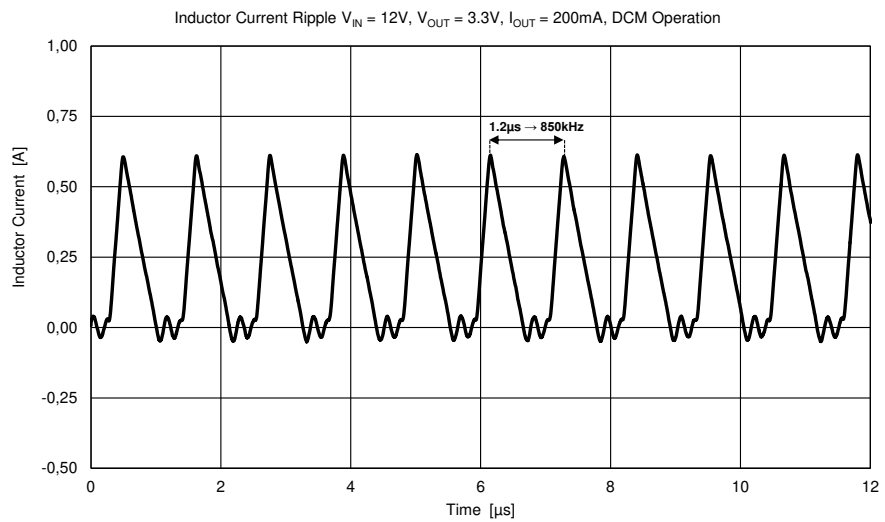
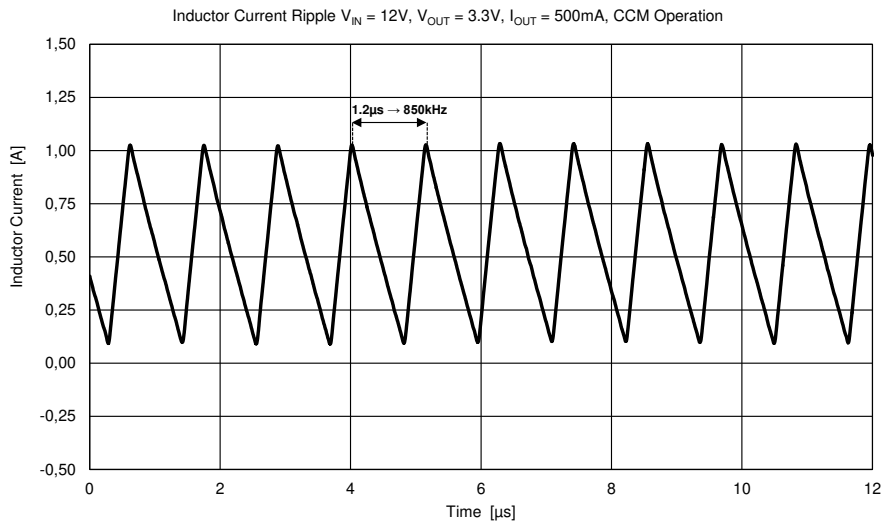

171021801

MagI³C Power Module

WPME-VDLM – Variable Step Down LGA Module



If the load current is further reduced, the device decreases the switching frequency in order to limit the energy transferred to the output (to both capacitor and load) and therefore keeping the output voltage regulated. The frequency reduction is shown in the figures below.

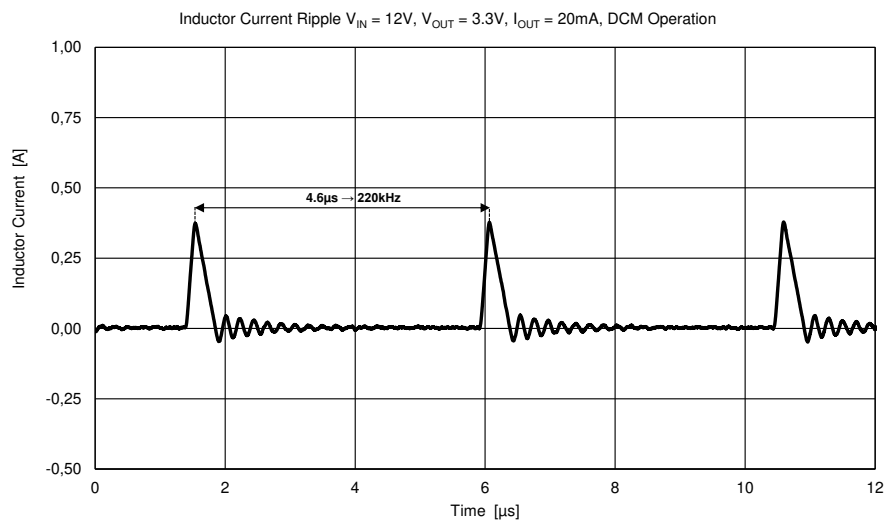
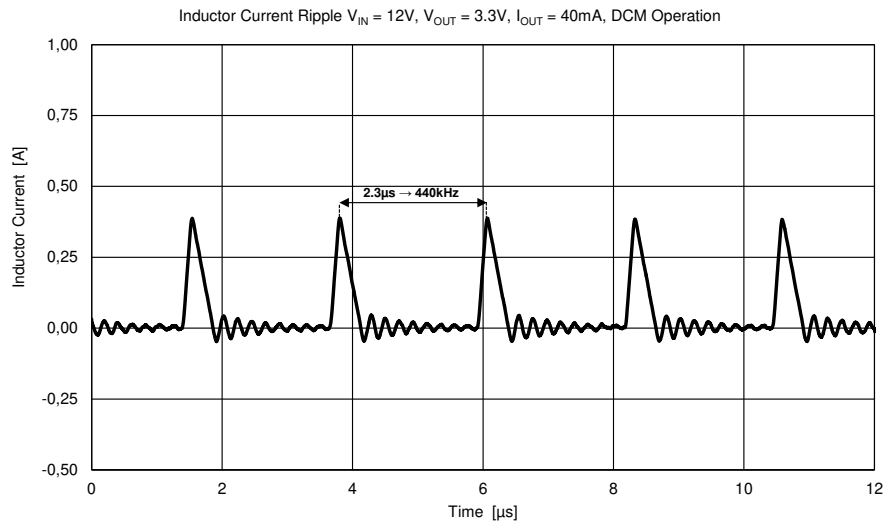

171021801

MagI³C Power Module

WPME-VDLM – Variable Step Down LGA Module



DROPOUT OPERATION

The dropout voltage is generally defined as the minimum voltage drop between the input and the output voltages necessary to keep the output voltage regulated. It is usually defined for linear regulators, but it applies also to DC-DC converters when they operate at 100% duty cycle.

The 171021801 integrates a p-channel MOSFET as high-side switch. Therefore this module does not need any bootstrap circuitry to create the gate voltage used for driving an n-channel MOSFET. The implementation of a p-channel MOSFET as high-side results in:

- there is no minimum off-time, normally necessary to provide the bootstrap circuitry with sufficient voltage
- the duty cycle can reach 100%, allowing the output voltage regulation even with a very limited voltage dropout

As the input voltage decreases and becomes closer to the output voltage, the duty-cycle rises and reaches then 100%.

The voltage dropout in case of 100% duty cycle operation depends fundamentally on the $R_{DS(on)}$ (resistance of the MOSFET when turned on) of the high-side MOSFET, on the DC resistance of the inductor (DCR) and on the load current.

The curve below shows the relation between the dropout voltage and the load current.

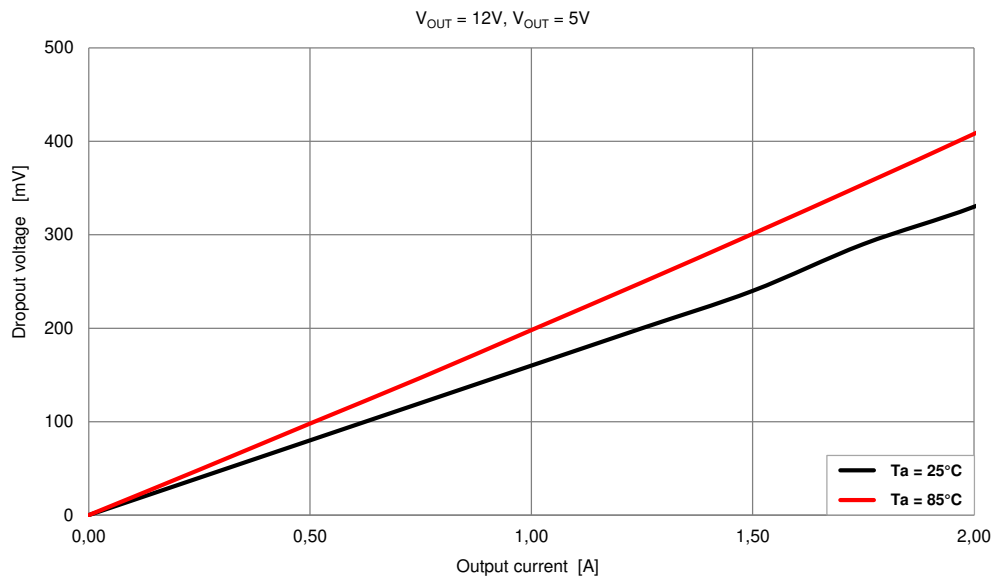

171021801

Mag³C Power Module
WPME-VDLM – Variable Step Down LGA Module



PROTECTING FEATURES

Overcurrent protection (OCP)

The overcurrent protection is implemented by sensing the peak current in the high-side power MOSFET during the on-time. When the peak current exceeds the current limit threshold (I_{CL} , see [ELECTRICAL SPECIFICATIONS](#) on page 5) the high-side MOSFET is immediately turned off. The current flows through the low-side MOSFET for the remaining time of the period (see figure below).

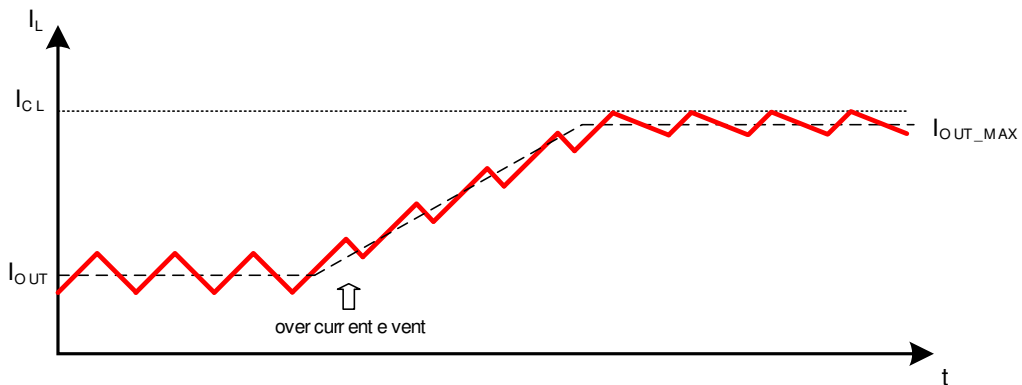

During overcurrent condition, the duty cycle is no longer determined by the control loop, it is instead limited by the current limit threshold. Therefore, the output voltage is out of regulation and drops (see figure below).

If the voltage at the feedback pin falls below 0.3V, the switching frequency (typ. 850kHz) is reduced to one fourth of the default value and the current limit threshold is folded back to 2A. This additional countermeasure prevents the module and the load from being overstressed by a severe overload condition.

The overcurrent threshold foldback is inhibited during the startup, hence allowing the output voltage to properly rise even in case of big output capacitors, which require a high current to be charged.

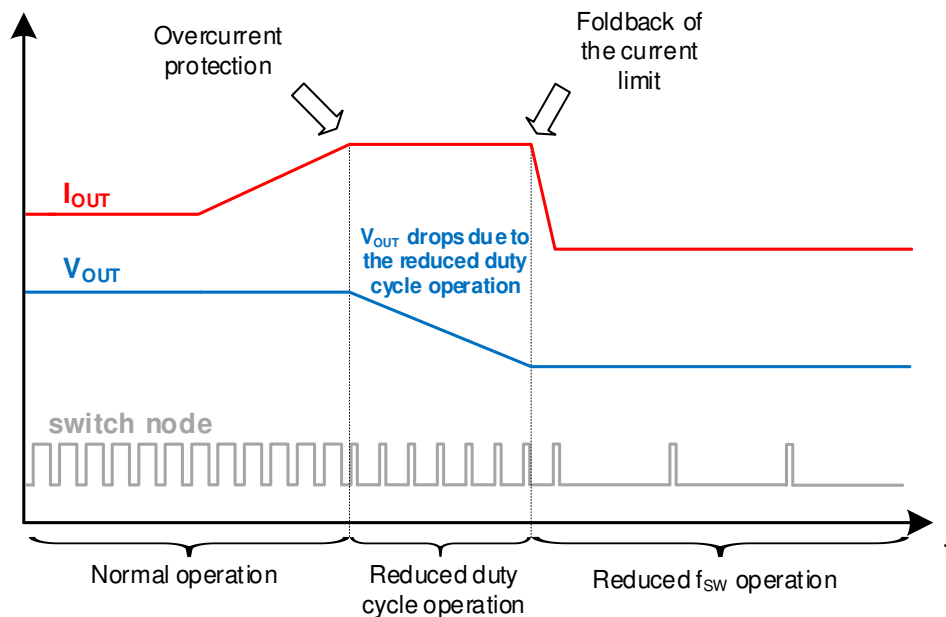

171021801

MagI³C Power Module
WPME-VDLM – Variable Step Down LGA Module



Short circuit protection

In case of short circuit condition, the module is protected by the current protection mechanism explained in the previous section. Since a short circuit is present at the output, the voltage at the feedback pin is surely below 0.3V. Therefore the current fold-back and the switching frequency reduction described above will take place after few switching cycles, as shown in the figure below.

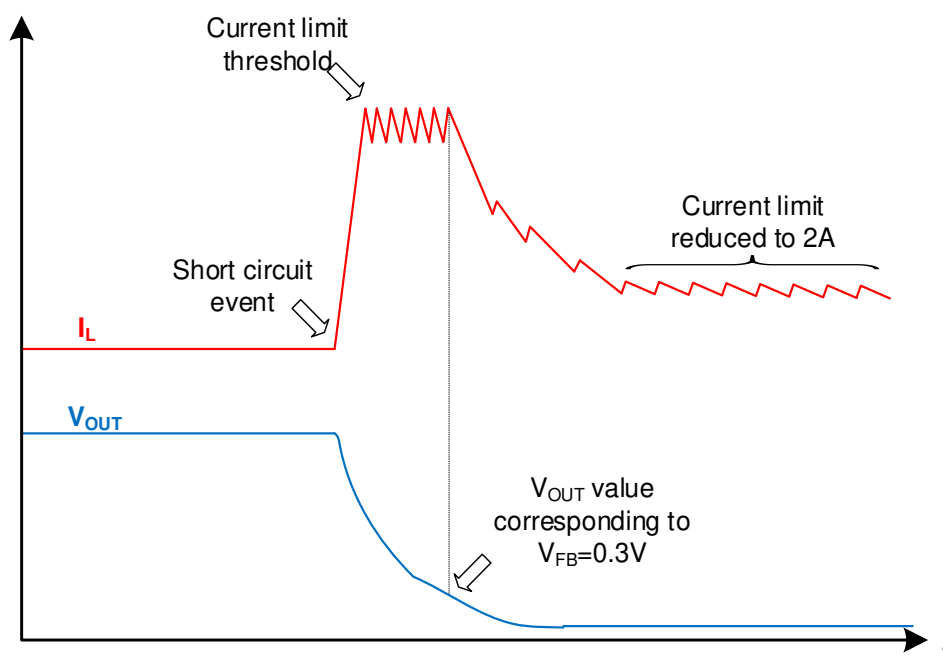

Overtemperature protection (OTP)

The overtemperature protection helps to prevent catastrophic failures in case of accidental device overheating. The junction temperature of the 171021801 should not be allowed to exceed its maximum rating. Thermal protection is implemented by an internal thermal shutdown circuit which activates at 150°C (typ.) causing the device to stop switching. In this state the V_{OUT} drops and additionally the internal soft-start capacitor is discharged. When the junction temperature falls back below approximately 135°C (typical hysteresis = 15°C) the soft-start circuitry is re-activated, V_{OUT} rises smoothly, and normal operation resumes.

171021801

MagI³C Power Module
WPME-V DLM – Variable Step Down LGA Module



DETERMINE POWER LOSSES AND THERMAL REQUIREMENTS OF THE BOARD

This section provides an example of estimation of power losses and definition of the thermal performance of the board. As a starting point, the following application conditions can be considered:

$$V_{IN}=12V, V_{OUT}=3.3V, I_{OUT}=2A, T_{A(MAX)} =85^{\circ}C \text{ and } T_{J(MAX)}=125^{\circ}C$$

where T_A is the maximum air temperature surrounding the module and $T_{J(MAX)}$ is the maximum value of the junction temperature according to the limits in the “OPERATING CONDITIONS” section on page 4.

The goal of the calculation is to determine the junction to ambient thermal resistance (θ_{JA}) that can be used to define the characteristics of the PCB on which the device will be mounted.

The basic formula for calculating the operating junction temperature T_J of a semiconductor device is as follows:

$$T_J = P_{LOSS_TOT} \cdot \theta_{JA} + T_A \tag{13}$$

P_{LOSS_TOT} are the total power losses within the module and are related to the operating conditions and θ_{JA} is the junction to ambient thermal resistance, defined as:

$$\theta_{JA} = \theta_{JC} + \theta_{CA} \tag{14}$$

where θ_{JC} is the junction to case thermal resistance and θ_{CA} is the case to ambient thermal resistance. From equation (13) the target junction to ambient thermal resistance can be derived:

$$\theta_{JA(MAX)} < \frac{T_{J(MAX)} - T_{A(MAX)}}{P_{LOSS_TOT}} \tag{15}$$

From the power dissipation’s diagram on page 10 (here below reported) a power loss of 1.16W is read.

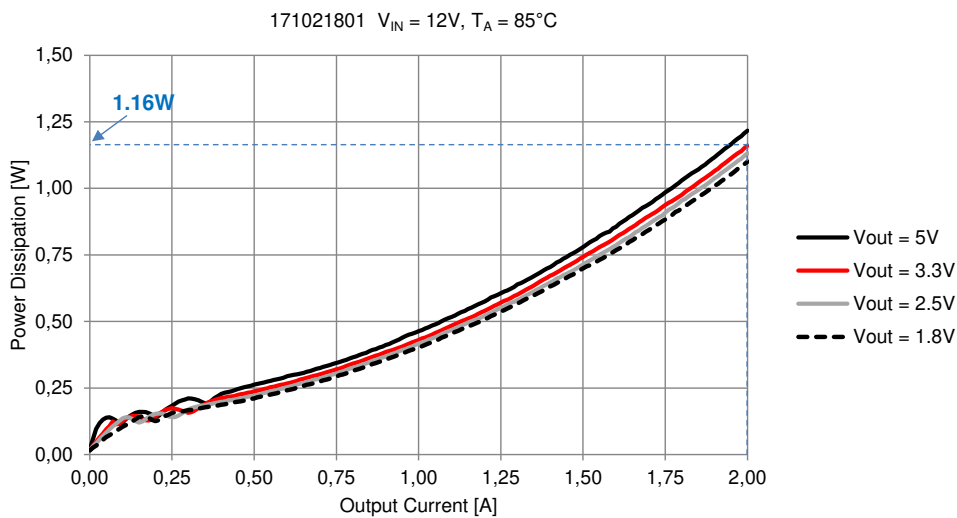

171021801**MagI³C** Power Module
WPME-VDLM – Variable Step Down LGA Module

Entering the values in formula (15) results in:

$$\theta_{JA(MAX)} < \frac{125^{\circ}\text{C} - 85^{\circ}\text{C}}{1.16\text{W}} = 34.5^{\circ}\text{C/W}$$

In order to fulfil the application conditions mentioned above, the PCB should at least provide a junction to ambient thermal resistance of 34.5°C/W.

171021801

MagI³C Power Module
WPME-VDLM – Variable Step Down LGA Module



TYPICAL SCHEMATIC

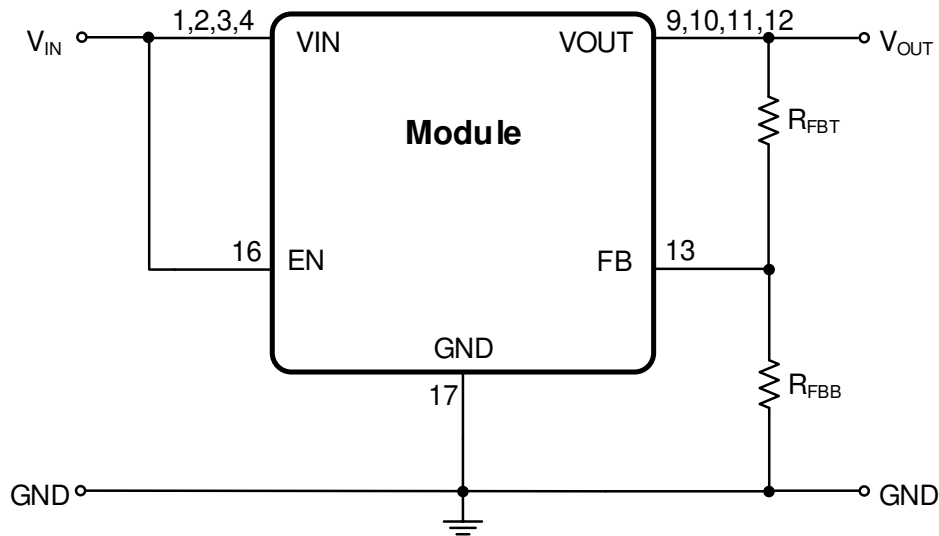

Quick setup guide

Conditions: $T_A = 25^\circ\text{C}$, $I_{OUT} = 2\text{A}$

Recommended component values

V_{OUT}	12V	9V	5V	3.3V	2.5V	1.8V
R_{FBT}	10 k Ω	10 k Ω	10 k Ω	10 k Ω	10 k Ω	10 k Ω
R_{FBB} (E96 series)	715 Ω	976	1.87k Ω	3.16k Ω	4.64k Ω	7.87k Ω
V_{IN}	12.7V – 18V	9.7V – 18V	5.7V – 18V	4V – 18V	4V – 18V	4V – 18V

171021801

MagI³C Power Module
WPME-VDLM – Variable Step Down LGA Module



LAYOUT RECOMMENDATION

PCB layout is an important part of DC-DC converter design. Poor board layout can disrupt the performance of a DC-DC converter and surrounding circuitry by contributing to EMI, ground bounce and resistive voltage drop in the traces. These can send erroneous signals to the DC-DC converter resulting in poor regulation or instability. A good layout can be implemented by following simple design rules.

Due to the integration of both the input and the output capacitors the user does not need to take care anymore of the switched current loops. The most critical paths, due to discontinuous current flows, are within the module and are already optimized in terms of EMI.

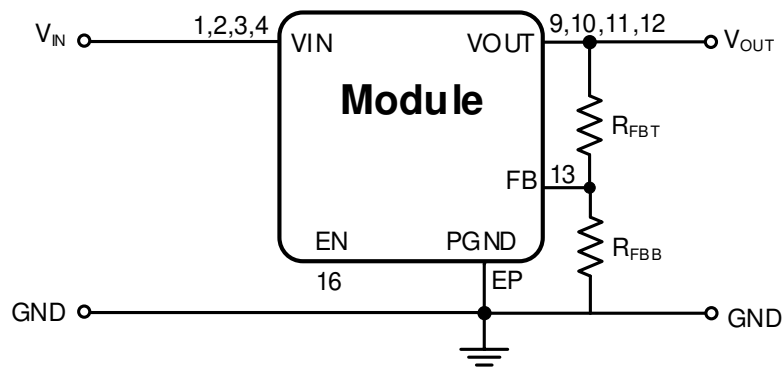

The only external components necessary to operate the 171021801 that must be placed on the PCB are the resistors of the output voltage divider, as shown in the picture above.

171021801

MagI³C Power Module
WPME-VDLM – Variable Step Down LGA Module



1: Feedback layout

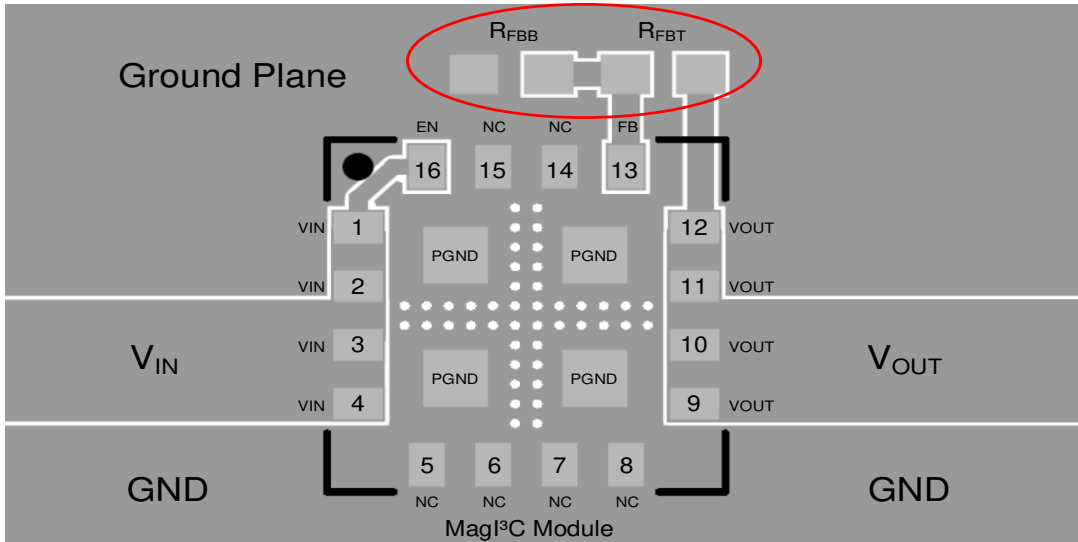

PCB colour coding: Top layer Bottom layer

The resistor divider (R_{FBT} and R_{FBB}) should be located close to the FB pin. Since the FB node is high impedance, the trace thickness should be kept small. The traces from the FB pin to the middle point of the resistor divider should be as short as possible. The upper terminal of the output resistor divider (where the V_{OUT} is applied) should have a short connection to the V_{OUT} pins, where internally are integrated the output capacitors.

2: Ground (PGND) connection of the resistor divider

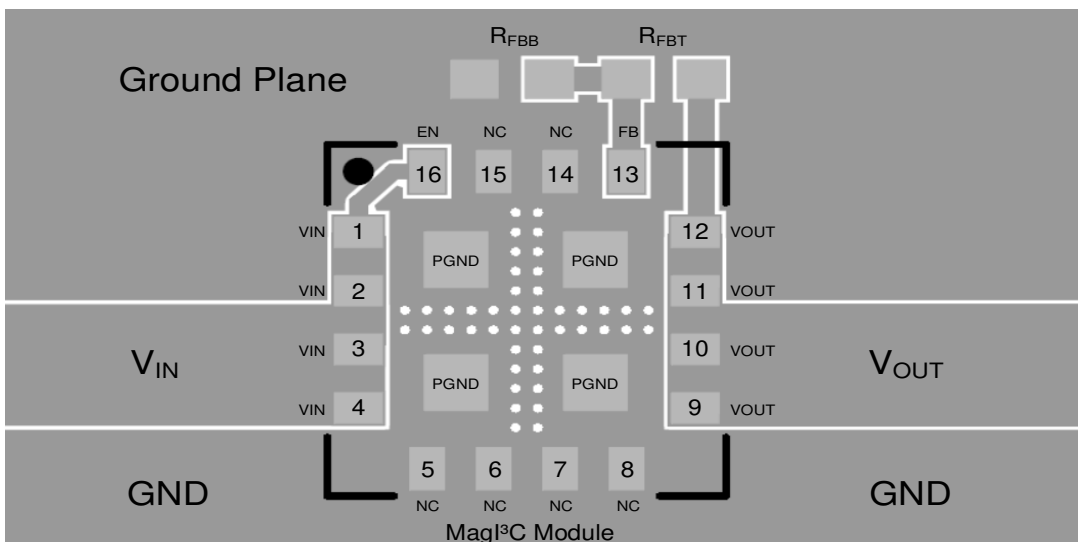

The ground connection of the lower resistor of the output voltage divider (R_{FBB}) should be routed to the PGND pins of the device. If not properly handled, poor grounding can result in degraded load regulation or erratic output voltage ripple behavior.

171021801

MagI³C Power Module
WPME-VDLM – Variable Step Down LGA Module



3: Make input and output bus connections as wide as possible

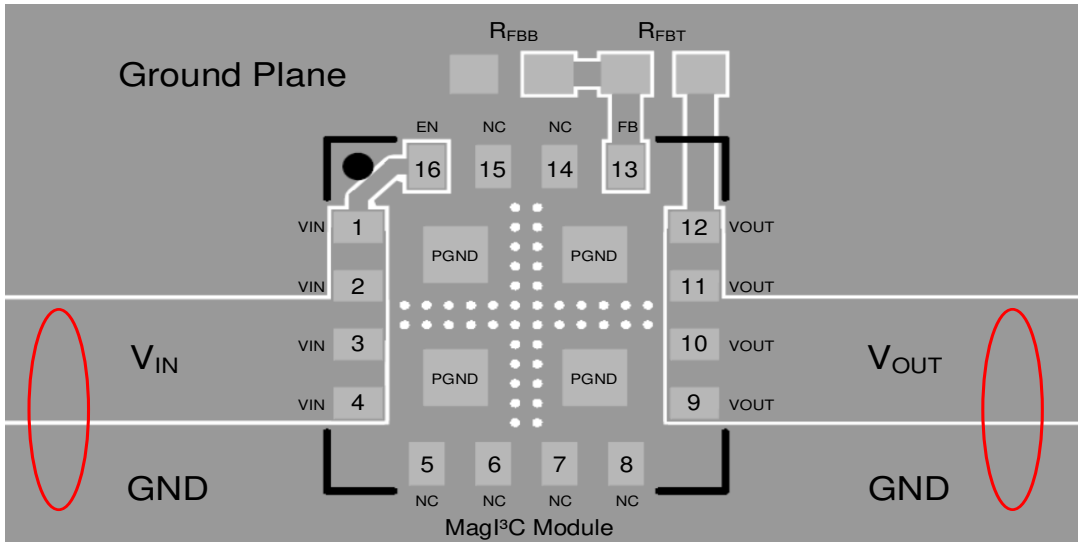

This reduces any voltage drops on the input or output of the converter and maximizes efficiency.

4: Place array of heat-sinking vias

Use an array of heat-sinking vias to connect the PGND pad to the ground plane on the bottom PCB layer. If the PCB has multiple of copper layers, these thermal vias can also be used to make a connection to the heat-spreading ground planes located on inner layers.

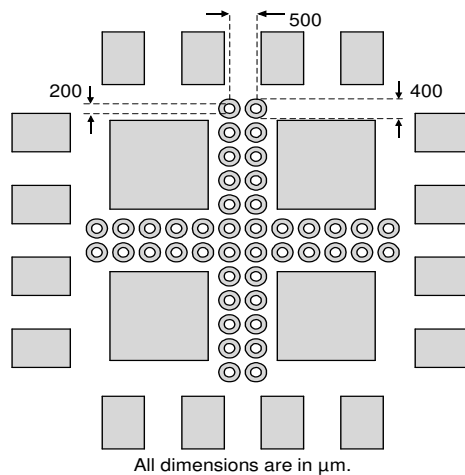

For best result, use a thermal via array as proposed in the picture above with drill of max 200µm, annular ring diameter of 400µm is recommended, vias spaced 500µm apart. Ensure enough copper area is used for heat-sinking, to keep the junction temperature below 125°C.

Connecting the NC pins (5,6,7,8) to the the GND layer helps dissipating the heat.

171021801

MagI³C Power Module
WPME-VDLM – Variable Step Down LGA Module



5: Isolate high noise areas

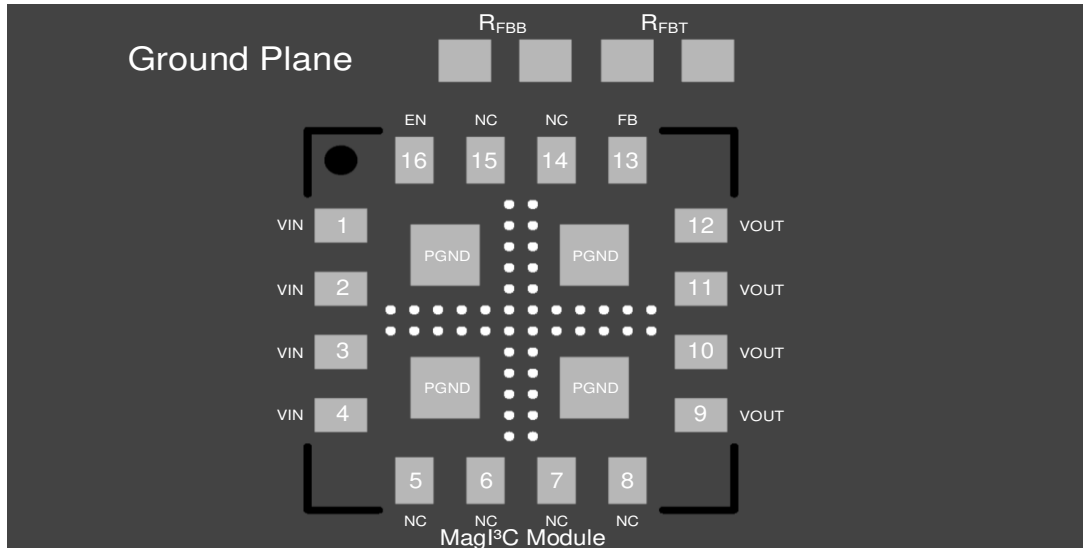

Place a dedicated solid ground copper area beneath the MagI³C Power Module.

Note:

The illustrated example of the PCB design is subject to the sole consideration of the module. In general, the optimal PCB, land pattern and stencil design depends on the respective application as well as the specific design rules of the selected PCB manufacturer and assembly service.

171021801

MagI³C Power Module WPME-VDLM – Variable Step Down LGA Module



EVALUATION BOARD SCHEMATIC (178021801 v.1.0)

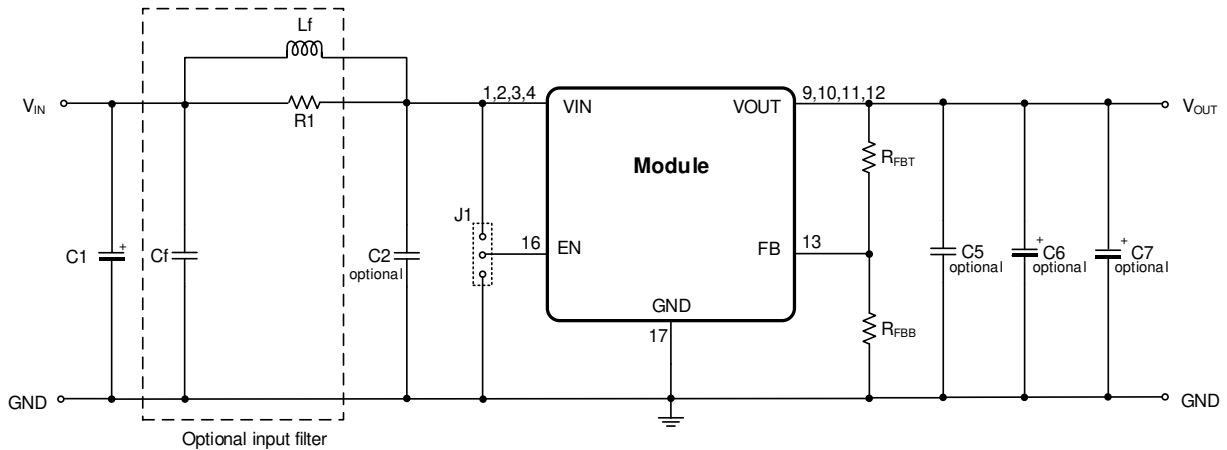

The 171021801 integrates both the input and output capacitors. Therefore, additional external input/output capacitors are normally not required.

The additional 220µF aluminum electrolytic capacitor C1 is mounted as termination of the supply line and provides a slight damping of possible oscillations of the series resonance circuit represented by the inductance of the supply line and the input capacitance.

The additional MLCC Cf is part of the input filter and is not mounted on the board. The inductor Lf is not mounted too (see recommended part number in the table below). A zero ohm resistor (R1) is mounted in parallel with Lf. In case the input filter is placed, R1 must be removed and an appropriate Lf mounted.

Although the 171021801 do not need any external output capacitor, in case particular application requirements are demanding additional capacitance, the evaluation board gives the possibility to place further capacitors at the output: C5 (MLCC), C6 (surface mounted electrolytic) and C7 (through hole electrolytic).

Bill of Material

Designator	Description	Quantity	Order Code	Manufacturer
IC1	MagI ³ C Power Module	1	171021801	Würth Elektronik
C1	Aluminum electrolytic capacitor, ATG5 family, 220µF/25V	1	860020474012	Würth Elektronik
C2	Ceramic chip capacitor (not mounted)	optional		
C5	Ceramic chip capacitor (not mounted)	optional		
C6	Surface mounted electrolytic (not mounted)	optional		
C7	Through hole electrolytic (not mounted)	optional		
Cf	Ceramic chip capacitor 10µF/25V X5R, 1206 (not mounted)	optional	885012108021	Würth Elektronik
Lf	Filter inductor, 10µH, PD2 (not mounted)	optional	74477510	Würth Elektronik
R1	SMD bridge 0Ω resistance	1		
RFBT	10kΩ	1		
RFBB	Set by jumper	715 Ω for V _{OUT} = 12V	1	
		976 Ω for V _{OUT} = 9V	1	
		1.87 kΩ for V _{OUT} = 5V	1	
		3.16 kΩ for V _{OUT} = 3.3V	1	
		4.64 kΩ for V _{OUT} = 2.5V	1	
		7.87 kΩ for V _{OUT} = 1.8V	1	
	For adjustable V _{OUT} : $R_{FBB} = \frac{R_{FBT} \cdot 0.8V}{V_{OUT} - 0.8V}$	optional		
J1	Jumper for ENABLE connection to either VIN or GND	1		

171021801

MagI³C Power Module

WPME-VDLM – Variable Step Down LGA Module



Filter suggestion for conducted EMI

The input filter shown in the schematic below is recommended to achieve conducted compliance according to EN55022 Class B (see results on page 7).

For radiated EMI the input filter is not necessary. It is only used to comply with the setup recommended by the norms.

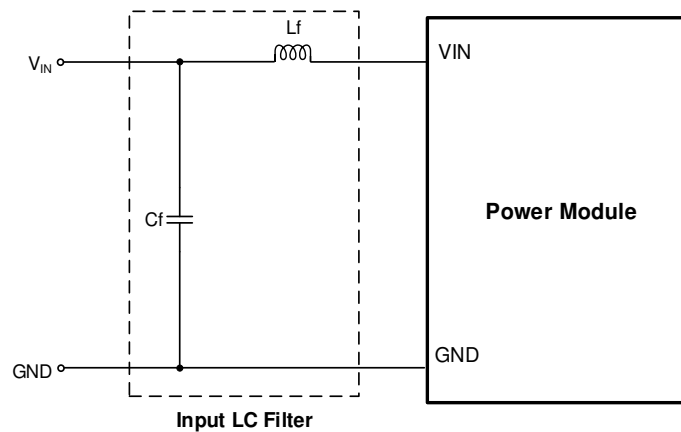

Bill of Material of the Input LC Filter

Designator	Description	Order Code	Manufacturer
C_f	Filter ceramic chip capacitor 10 μ F/25V X5R, 1206	885012108021	Würth Elektronik
L_f	Filter inductor, 10 μ H, PD2 family	74477510	Würth Elektronik

171021801

MagI³C Power Module

WPME-VDLM – Variable Step Down LGA Module



HANDLING RECOMMENDATIONS

1. The power module is classified as MSL3 (JEDEC Moisture Sensitivity Level 3) and requires special handling due to moisture sensitivity (JEDEC J-STD033).
2. The parts are delivered in a sealed bag (Moisture Barrier Bags = MBB) and should be processed within one year.
3. When opening the moisture barrier bag check the Humidity Indicator Card (HIC) for color status. Bake parts prior to soldering in case indicator color has changed according to the notes on the card.
4. Parts must be processed after 168 hour (7 days) of floor life. Once this time has been exceeded, bake parts prior to soldering per JEDEC J-STD033 recommendation.

SOLDER PROFILE

1. Only Pb-Free assembly is recommended according to JEDEC J-STD020.
2. Measure the peak reflow temperature of the MagI³C power module in the middle of the top view.
3. Ensure that the peak reflow temperature does not exceed 235°C ±5°C as per JEDEC J-STD020.
4. The reflow time period during peak temperature of 235°C ±5°C must not exceed 20 seconds.
5. Reflow time above liquidus (217°C) must not exceed 60 seconds.
6. Maximum ramp up is rate 3°C per second
7. Maximum ramp down rate is 3°C per second
8. Reflow time from room (25°C) to peak must not exceed 8 minutes as per JEDEC J-STD020.
9. **Maximum numbers of reflow cycles is two.**
10. **For minimum risk, solder the module in the last reflow cycle of the PCB production.**
11. For soldering process please consider lead material copper (Cu) and lead finish tin (Sn).
12. For solder paste use a standard SAC Alloy such as SAC 305, type 3 or higher.
13. Below profile is valid for convection reflow only
14. Other soldering methods (e.g.vapor phase) are not verified and have to be validated by the customer on his own risk

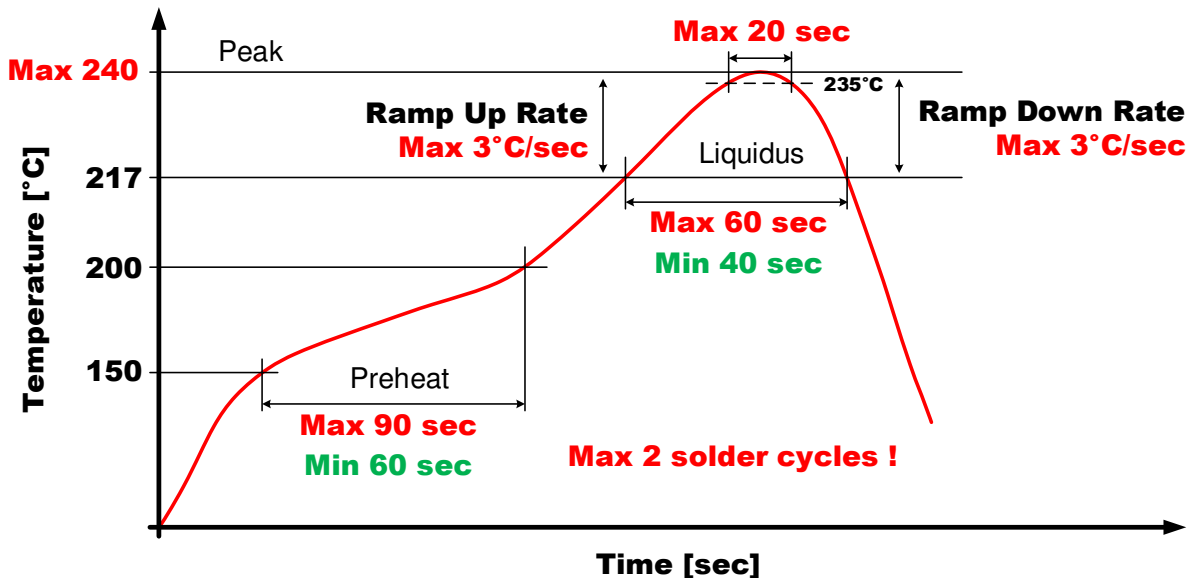

171021801

MagI³C Power Module
WPME-VDLM – Variable Step Down LGA Module



PHYSICAL DIMENSIONS

Package type: LGA-16EP

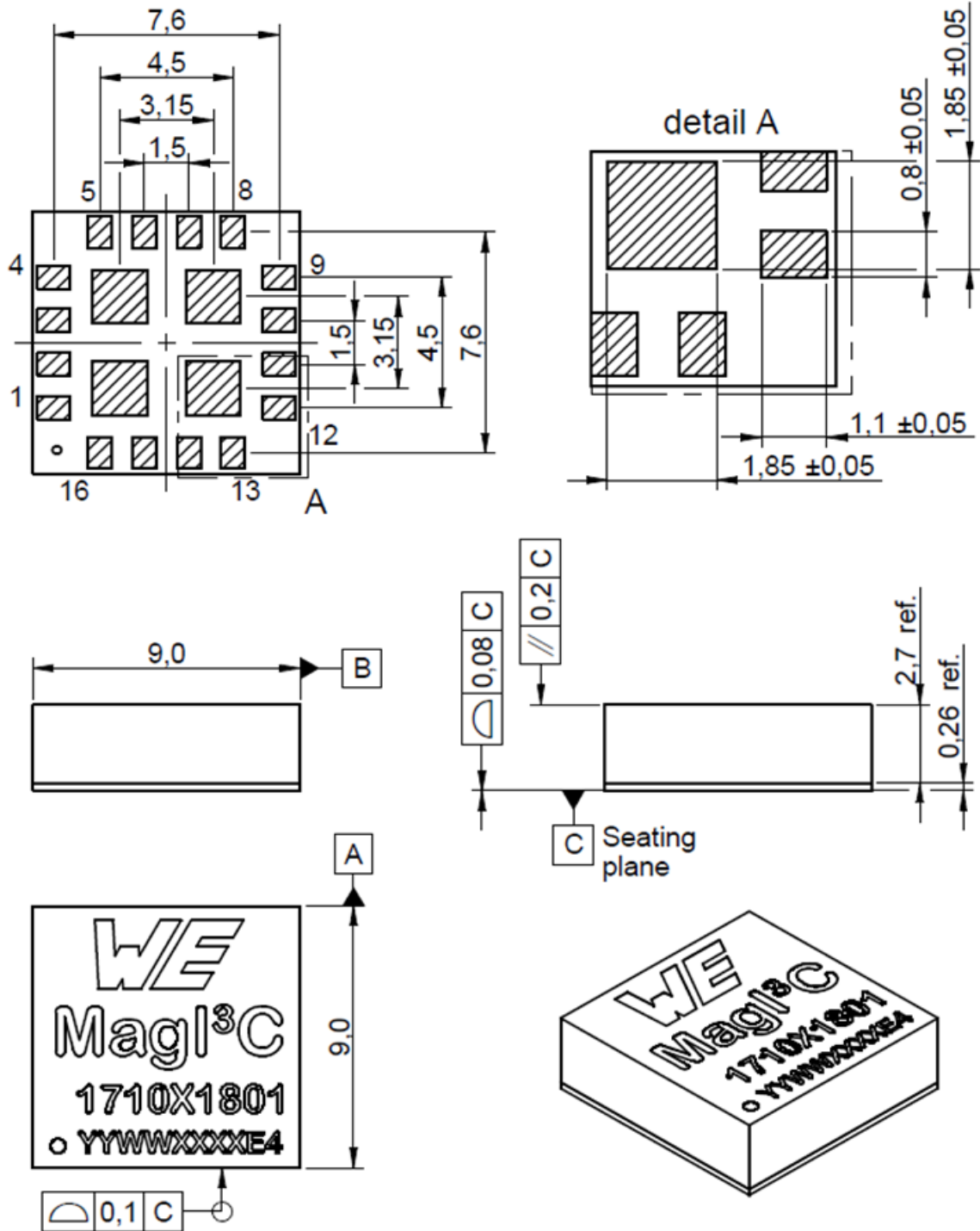

All dimensions are in mm

171021801

MagI³C Power Module
WPME-VDLM – Variable Step Down LGA Module



RECOMMENDED LAND PATTERN DESIGN

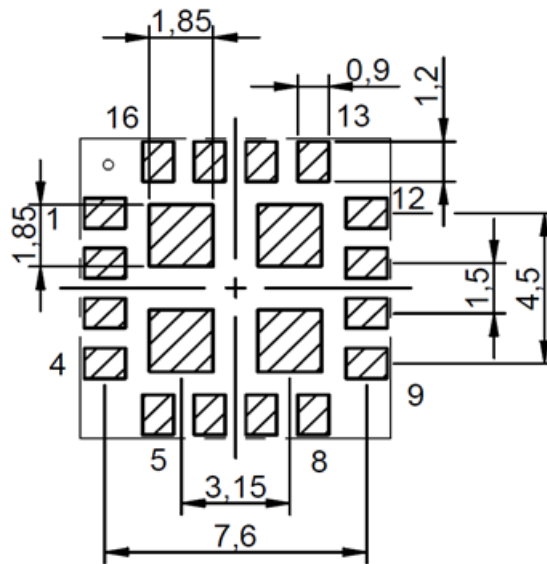

All dimensions are in mm

RECOMMENDED SOLDER STENCIL DESIGN

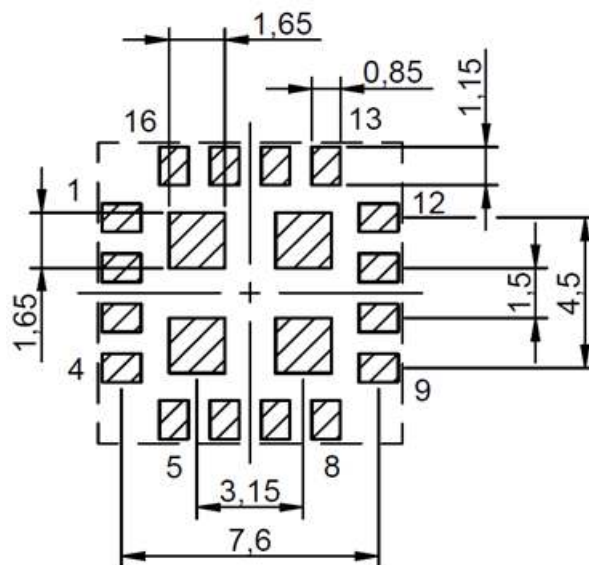

All dimensions are in mm

171021801

MagI³C Power Module
WPME-VDLM – Variable Step Down LGA Module



PACKAGING

Reel (mm)

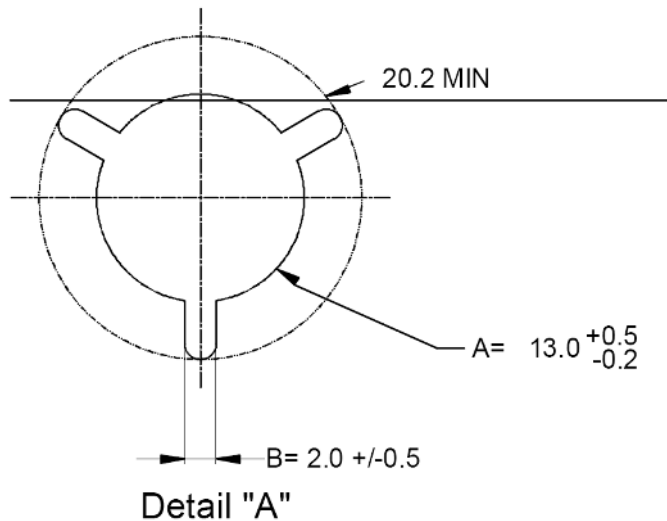
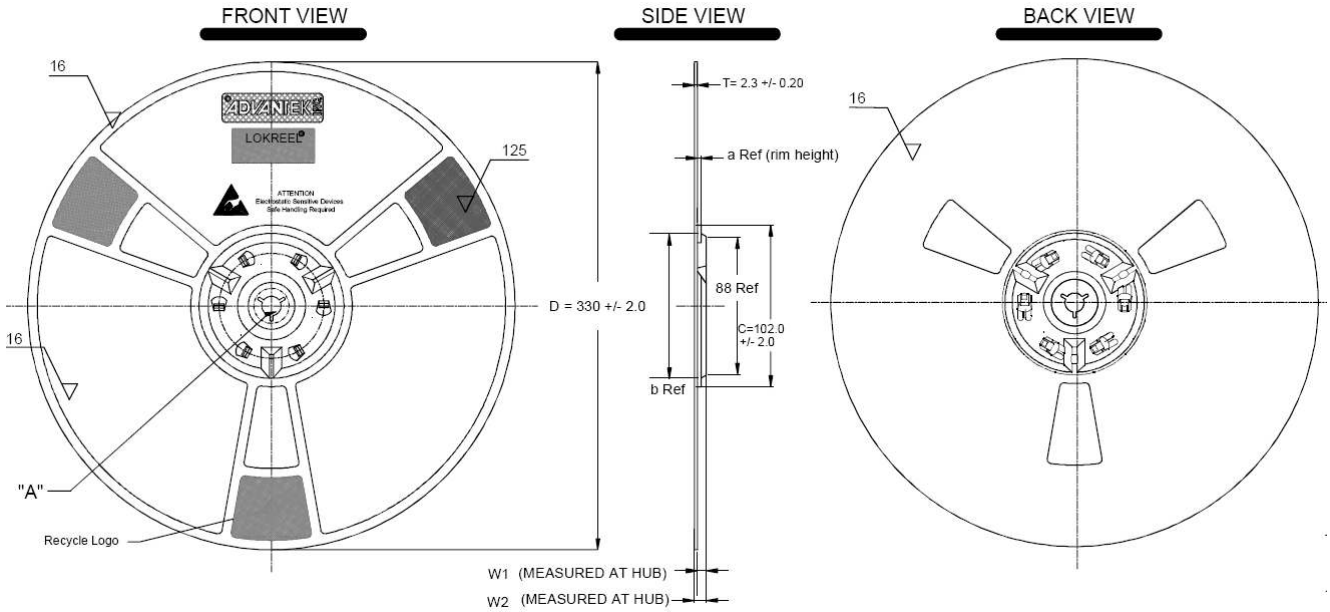

Nominal Hub Width	W1 +0.3mm/-0.2mm	W2 MAX	a	b
16mm	16.4mm	19.1mm	4.5	98.0

171021801

MagI³C Power Module
WPME-VDLM – Variable Step Down LGA Module



Tape (mm)

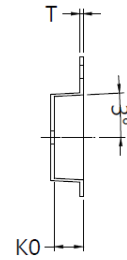
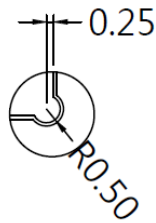
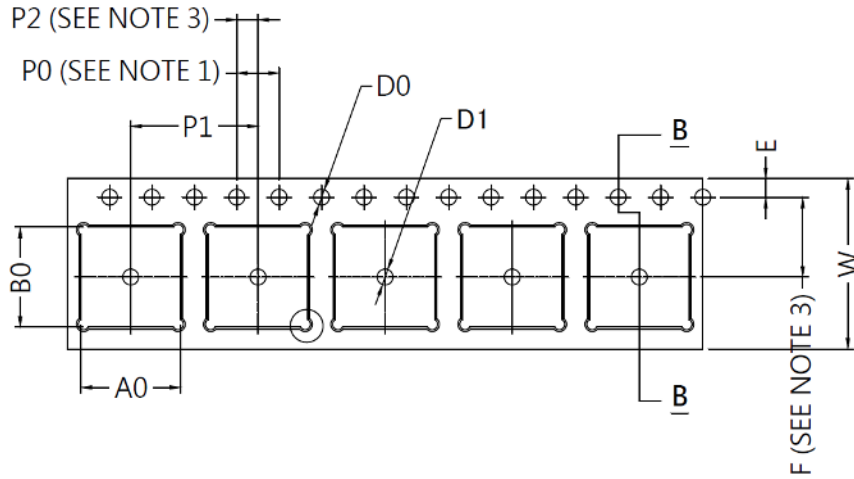

SECTION B-B

Item	Specification	Tol. (+/-)	Item	Specification	Tol. (+/-)
W	16.00	±0.30	A0	9.40	±0.10
E	1.75	±0.10	B0	9.40	±0.10
F	7.50	±0.10	K0	3.30	±0.10
D0	1.50	+0.1/-0.0	T	0.35	±0.05
D1	1.50	+0.1/-0.0			
P0	4.00	±0.10			
P1	12.00	±0.10			
P2	2.00	±0.10			

NOTES:

1. 10 Sprocket hole pitch cumulative tolerance ±0.2
2. Camber in compliance with EIA 481
3. Pocket position relative to sprocket hole measured as true position of pocket, not pocket hole

171021801

MagI³C Power Module
WPME-VDLM – Variable Step Down LGA Module



DOCUMENT HISTORY

Revision	Date	Description	Comment
1.0	January 2018	Release of the final version	
1.1	April 2020	Change in recommended layout section	Updated recommended layout section to improve module solderability.
2.0	November 2021	Updated thermal derating and changed mold compound and solder paste	New measurement results shown in thermal derating graph Package specifications updated with new mold compound

171021801

MagI³C Power Module

WPME-VDLM – Variable Step Down LGA Module



CAUTIONS AND WARNINGS

The following conditions apply to all goods within the product series of MagI³C of Würth Elektronik eiSos GmbH & Co. KG:

General:

All recommendations according to the general technical specifications of the datasheet have to be complied with.

The usage and operation of the product within ambient conditions which probably alloy or harm the component surface has to be avoided.

The responsibility for the applicability of customer specific products and use in a particular customer design is always within the authority of the customer. All technical specifications for standard products do also apply for customer specific products.

Residual washing varnish agent that is used during the production to clean the application might change the characteristics of the body, pins or termination. The washing varnish agent could have a negative effect on the long term function of the product.

Direct mechanical impact to the product shall be prevented as the material of the body, pins or termination could flake or in the worst case it could break. As these devices are sensitive to electrostatic discharge customer shall follow proper IC Handling Procedures.

Customer acknowledges and agrees that it is solely responsible for compliance with all legal, regulatory and safety-related requirements concerning its products, and any use of Würth Elektronik eiSos GmbH & Co. KG components in its applications, notwithstanding any applications-related information or support that may be provided by Würth Elektronik eiSos GmbH & Co. KG. Customer represents and agrees that it has all the necessary expertise to create and implement safeguards which anticipate dangerous consequences of failures, monitor failures and their consequences lessen the likelihood of failures that might cause harm and take appropriate remedial actions. Customer will fully indemnify Würth Elektronik eiSos and its representatives against any damages arising out of the use of any Würth Elektronik eiSos GmbH & Co. KG components in safety-critical applications.

The illustrated example of the PCB design is subject to the sole consideration of the module. In general, the optimal PCB, land pattern and stencil design depends on the respective application as well as the specific design rules of the selected PCB manufacturer and assembly service.

Product specific:

Follow all instructions mentioned in the datasheet, especially:

- The solder profile has to comply with the technical reflow or wave soldering specification, otherwise this will void the warranty.
- All products are supposed to be used before the end of the period of 12 months based on the product date-code.
- Violation of the technical product specifications such as exceeding the absolute maximum ratings will void the warranty.
- It is also recommended to return the body to the original moisture proof bag and reseal the moisture proof bag again.
- ESD prevention methods need to be followed for manual handling and processing by machinery.

171021801

MagI³C Power Module

WPME-VDLM – Variable Step Down LGA Module



IMPORTANT NOTES

The following conditions apply to all goods within the product range of Würth Elektronik eiSos GmbH & Co. KG:

1. General Customer Responsibility

Some goods within the product range of Würth Elektronik eiSos GmbH & Co. KG contain statements regarding general suitability for certain application areas. These statements about suitability are based on our knowledge and experience of typical requirements concerning the areas, serve as general guidance and cannot be estimated as binding statements about the suitability for a customer application. The responsibility for the applicability and use in a particular customer design is always solely within the authority of the customer. Due to this fact it is up to the customer to evaluate, where appropriate to investigate and decide whether the device with the specific product characteristics described in the product specification is valid and suitable for the respective customer application or not. Accordingly, the customer is cautioned to verify that the datasheet is current before placing orders.

2. Customer Responsibility related to Specific, in particular Safety-Relevant Applications

It has to be clearly pointed out that the possibility of a malfunction of electronic components or failure before the end of the usual lifetime cannot be completely eliminated in the current state of the art, even if the products are operated within the range of the specifications. In certain customer applications requiring a very high level of safety and especially in customer applications in which the malfunction or failure of an electronic component could endanger human life or health it must be ensured by most advanced technological aid of suitable design of the customer application that no injury or damage is caused to third parties in the event of malfunction or failure of an electronic component.

3. Best Care and Attention

Any product-specific notes, warnings and cautions must be strictly observed.

4. Customer Support for Product Specifications

Some products within the product range may contain substances which are subject to restrictions in certain jurisdictions in order to serve specific technical requirements. Necessary information is available on request. In this case the field sales engineer or the internal sales person in charge should be contacted who will be happy to support in this matter.

5. Product R&D

Due to constant product improvement product specifications may change from time to time. As a standard reporting procedure of the Product Change Notification (PCN) according to the JEDEC-Standard we inform about minor and major changes. In case of further queries regarding the PCN, the field sales engineer or the internal sales person in charge should be contacted. The basic responsibility of the customer as per Section 1 and 2 remains unaffected.

6. Product Life Cycle

Due to technical progress and economical evaluation we also reserve the right to discontinue production and delivery of products. As a standard reporting procedure of the Product Termination Notification (PTN) according to the JEDEC-Standard we will inform at an early stage about inevitable product discontinuance. According to this we cannot guarantee that all products within our product range will always be available. Therefore it needs to be verified with the field sales engineer or the internal sales person in charge about the current product availability expectancy before or when the product for application design-in disposal is considered. The approach named above does not apply in the case of individual agreements deviating from the foregoing for customer-specific products.

7. Property Rights

All the rights for contractual products produced by Würth Elektronik eiSos GmbH & Co. KG on the basis of ideas, development contracts as well as models or templates that are subject to copyright, patent or commercial protection supplied to the customer will remain with Würth Elektronik eiSos GmbH & Co. KG. Würth Elektronik eiSos GmbH & Co. KG does not warrant or represent that any license, either expressed or implied, is granted under any patent right, copyright, mask work right, or other intellectual property right relating to any combination, application, or process in which Würth Elektronik eiSos GmbH & Co. KG components or services are used.

8. General Terms and Conditions

Unless otherwise agreed in individual contracts, all orders are subject to the current version of the "General Terms and Conditions of Würth Elektronik eiSos Group", last version available at www.we-online.com.