

H  
G  
F  
E  
D  
C  
B  
A

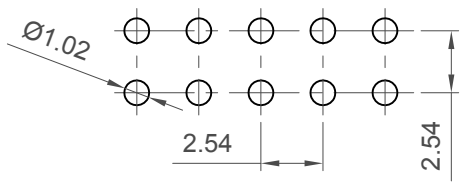

**Recommended PCB Layout**  
Tolerance: ±0.05mm

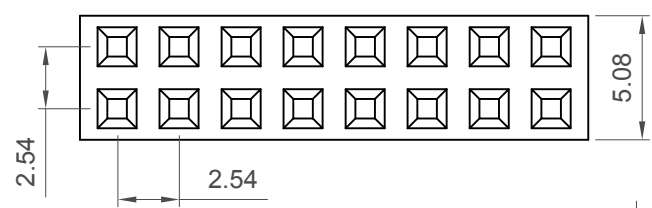
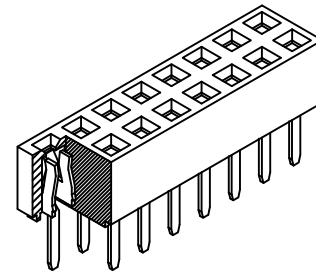

Insertion Depth & Pin Size Table			
Insulator Height 'H' (mm)	Min Insertion Depth (mm)	Max Insertion Depth (mm)	Pin Size (mm)
A=5.0	1.49	5.00	0.70 x 0.25
B=7.1	2.03	5.00	0.60 x 0.25

Min. Insertion Depth (See Table)  
Max. Insertion Depth (See Table)

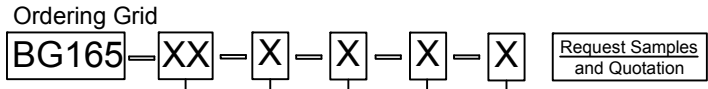
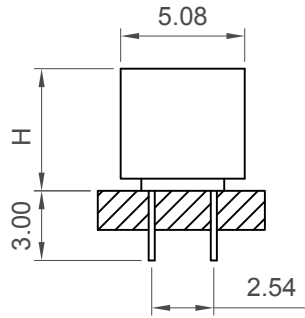
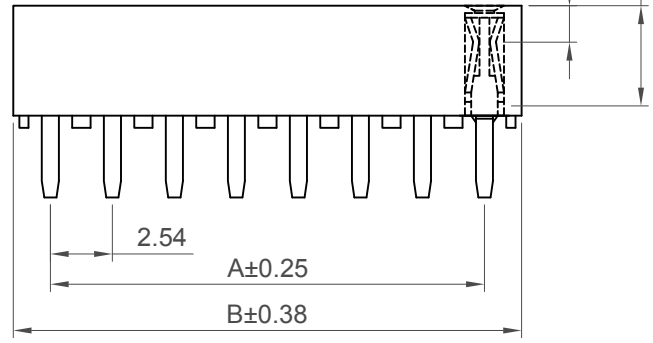

No. of Contacts  
04 to 80

Packing Options  
D = Tube (Standard)  
E = Tube with Cap  
F = Tube with Film  
G = Plastic Box  
H = Tray (4 contacts only)

Insulator Material  
N = Nylon 6T (Standard)  
P = PBT  
L = LCP

Contact Plating  
A = Gold Flash All Over (Standard)  
B = Selective Gold Flash Contact Area/Tin On Tail  
C = Tin All Over  
G = 10µ" Gold Contact Area/Tin On Tail  
I = 30µ" Gold Contact Area/Tin On Tail

Height H  
A = 5.0mm (Standard)  
B = 7.1mm

**Specifications**

**Material**  
Contact: Copper Alloy  
Insulator:  
Standard: Polyamide, Nylon 6T, UL 94V-0  
Options: Polymer, LCP, UL 94V-0  
Polyester, PBT, UL 94V-0

**Plating**  
See ordering grid.

**Electrical**  
Current Rating: 3 Amp (per contact)  
Contact Resistance: 20 mΩ max.  
Insulation Resistance: 1000 MΩ min.  
Dielectric Withstand Voltage: 600 V AC

**Mechanical & Environmental**  
Operating Temperature: -40°C to +105°C

**Soldering Process:**  
Nylon 6T (Standard):  
IR Reflow: 260°C for 10 sec.  
Wave: 230°C for 5-10 sec.  
Manual Solder: 350°C for 3-5 sec  
PBT (Option)  
Manual solder: 330°C for 3-5 sec.  
(Not suitable for hi-temp process)  
LCP (Option):  
IR Reflow: 260°C for 10 sec.  
Wave: 250°C for 5-10 sec.  
Manual Solder: 350°C for 3-5 sec

Mates with (Subject to pin length)  
BG025 BG040 BG041 BG045 BG050  
BG065 BG066 BG070 BG085

Number of Contacts	Dimensions	
	A	B
4	2.54	5.58
6	5.08	8.12
8	7.62	10.66
10	10.16	13.20
12	12.70	15.74
14	15.24	18.28
16	17.78	20.82
18	20.32	23.36
20	22.86	25.90
22	25.40	28.44
24	27.94	30.98
26	30.48	33.52
28	33.02	36.06
30	35.56	38.60
32	38.10	41.14
34	40.64	43.68
36	43.18	46.22
38	45.72	48.76
40	48.26	51.30
42	50.80	53.84
44	53.34	56.38
46	55.88	58.92
48	58.42	61.46
50	60.96	64.00
52	63.50	66.54
54	66.04	69.08
56	68.58	71.62
58	71.12	74.16
60	73.66	76.70
62	76.20	79.24
64	78.74	81.78
66	81.28	84.32
68	83.82	86.86
70	86.36	89.40
72	88.90	91.94
74	91.44	94.48
76	93.98	97.02
78	96.52	99.56
80	99.06	102.10

Part Number		Product Description	
BG165		2.54mm Pitch Socket	
Drawing Date		Dual Row, Through-Hole, Vertical	
30th October 2006			
By	CC	Tolerances (Except as Noted)	Units:
Detail	BG165 G PCN	Length X. ± 0.30 X.X ± 0.20 X.XX ± 0.15 X.XXX ± 0.10	Metric (mm)
Revision	G2	Angle X° ± 5° X.X° ± 2° X.XX° ± 1° X.XXX° ± 0.5°	
Date	20/11/17		



This drawing is confidential and copyright of Global Connector Technology, Ltd (GCT). This drawing must not be copied or disclosed without written consent. E & OE



Not to Scale	Drawn By LYH	Sheet No. 1/1
--------------	--------------	---------------