

PART NUMBER	REVISION	DESCRIPTION	FEED TYPE
2150311-2	B	FINE CRIMP HEIGHT ADJUST	PNEUMATIC
7-2150311-2	B	PNEUMATIC AND CRIMP TOOLING KIT	PNEUMATIC
7-2150311-7	A	CRIMP TOOLING KIT	-

ATLANTIC VERSION TERMINATOR INTERFACE ADAPTER

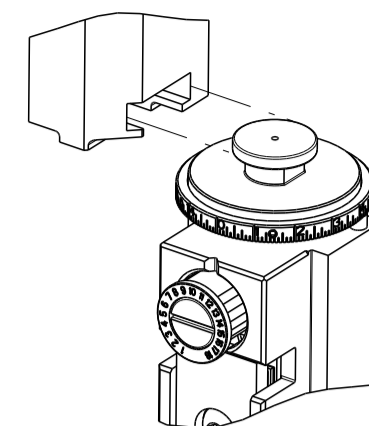

APPLICATOR DATA		
CRIMP	SIZE	TYPE
WIRE	2.03 mm [.080]	F
INSUL	3.56 mm [.140]	F
APPL INSTRUCTIONS 408-35043		

TERMINAL DATA: LEAR TERMINAL TE CRIMP SPECIFICATION			
TERMINAL NAME: TERMINAL			
WIRE STRIP LENGTH	INSULATION DIAMETER RANGE		
4.75-5.35 mm [.187-.211 IN]	Ø 2.92 mm MAX [0.115 IN MAX]		
TERMINAL APPLICATION SPECIFICATION	TE SPEC		
TERMINALS APPLIED			
TE TERMINAL	LEAR TERMINAL	TE TERMINAL	LEAR TERMINAL
2114314-1	25697.126.009	2113314-4	25697.213.009
2114314-2	25697.126.142	2113314-5	25697.213.141
2114314-3	25697.126.178	2113314-6	25697.213.178

WIRE SIZE	CRIMP HEIGHT mm [INCH]	CRIMP HEIGHT REFERENCE SETTING
1.00mm2	1.49 +/- 0.05 [0.059 +/- .002]	7.8
0.75mm2	1.39 +/- 0.05 [0.055 +/- .002]	8.8
0.50mm2	1.29 +/- 0.05 [0.051 +/- .002]	10.0



- 1 RECOMMENDED SPARE PARTS
- 2 REFER TO SUPPLIED INSTRUCTION SHEET FOR CLEANING, LUBRICATION AND STORAGE OF APPLICATOR.
- 3 APPLY PART NUMBER 2-23419-6 LOCTITE TO THREADS OF ITEM 242. APPLY PART NUMBER 1-23419-5 LOCTITE TO THREADS OF ITEM 180.
- 4 CRIMP HEIGHT REFERENCE SETTING WAS THE SETTING USED WHEN THE APPLICATOR WAS QUALIFIED AT THE FACTORY. ADJUSTMENT MAY BE NECESSARY WHEN RUNNING APPLICATOR IN THE FIELD.
- 5 TERMINAL PITCH NOT COMPATIBLE WITH MECHANICAL FEED.
- 6 UNLESS SPECIFIED OTHERWISE TORQUE VALUES SHALL BE USED PER DOCUMENT, 101-35000.

***WARNING**
ON INSTALLATION, SET WIRE DISC TO CRIMP HEIGHT REFERENCE SETTING FOR LARGEST WIRE SIZE. CRIMP HEIGHT REFERENCE SETTINGS GREATER THAN THE VALUE SHOWN MAY CAUSE DAMAGE TO THE CRIMP TOOLING. REFER TO THE INSTRUCTION SHEET FOR PROPER SETUP AND ADJUSTMENTS.

LOC	DIST	REVISIONS					
		P	LTN	DESCRIPTION	DATE	DWN	APVD
A	66	1		DEVELOPMENT	22JAN2013	YY	SX
		A		RELEASED	22MAR2013	YY	UG
		B		ECR-19-017433	08NOV2019	TB	RK

-	1	1	2119641-1	FEED CAM, AIR FEED	248
-	1	1	2119082-9	CAM, SNAIL, INSULATION ADJUSTMENT	244
-	1	1	2079764-1	WASHER, WAVE SPRING, CREST-TO-CREST	243
-	1	1	2119083-1	RETAINER, INSULATION DIAL	242
-	1	1	2844940-4	AIR FEED MODULE	238
-	1	1	1-18028-0	WASHER, FLAT, REG M8	192
-	1	1	1976055-3	STANDOFF, HOLD-DOWN	180
-	1	1	6-993111-6	PIN, SLOTTED SPRING 3.0 X 14.0	177
-	1	1	8-22280-7	SPRING, COMPRESSION	176
-	1	1	1752353-2	GUIDE PIN,HOLDDOWN	175
-	1	1	1901680-2	GUIDE PIN,HOLDDOWN	174
-	REF	REF	994970-2	COUNTER, MAGNETIC	164
-	1	1	455888-4	SPACER, CRIMPER	82
-	1	1	1803607-4	DOCUMENTATION PACKAGE	71
-	2	2	2-18032-2	SCR, SET, FLT PNT, M3 X 10.0	70
-	1	1	2119740-1	TAG,IDENTIFICATION	67
-	2	2	2168078-1	SCREW, DRIVE, RH, RoHS, 2 x .188	66
-	1	1	1976052-1	HOLDDOWN,TERMINAL	65
-	1	1	2168083-2	SCR, SKT HD CAP, RoHS, M4 X 8.0	60
-	1	1	5-18022-5	SCR, HEX HD CAP, M4 X 6.0	59
-	4	4	2168400-4	SHCS, LOW HEAD, RoHS, M4 X 8	57
-	2	2	2168083-9	SCR, SKT HD CAP, RoHS, M4 X 20	56
-	2	2	5018030-1	NUT, HEX, REG, RoHS, M3	54
-	2	2	986965-8	NUT, LOCK, HEX, TORQUE (M4)	53
-	1	1	1-5018030-0	NUT, HEX, REG, RoHS, M3.5	52
-	1	1	2063961-1	FEED FINGER	51
-	1	1	18023-9	SCR, SKT HD CAP M4 X 6.0	49
-	1	1	2119655-5	APPLICATOR BASIC ASSEMBLY, EF	46
-	1	1	1803517-1	RAM ASSEMBLY, EF ATLANTIC	44
-	1	1	1803602-1	SCR, BHSC, RoHS (M8 X 25)	41
-	8	8	1-18028-2	WASHER, FLAT, REG M4	33
-	2	2	2168083-9	SCR, SKT HD CAP, RoHS, M4 X 20	31
-	2	2	2168083-2	SCR, SKT HD CAP, RoHS, M4 X 8.0	29
-	1	1	240639-1	STRIPPER (MACHINING)	27
-	2	2	1-2168083-5	SCR, SKT HD CAP, RoHS, M4 X 30	25
-	1	1	1752371-5	PLATE, STRIP GUIDE	24
-	2	2	2-22281-3	SPRING, COMPRESSION	22
-	1	1	1803292-4	DRAG	20
-	1	1	1901696-3	STRIP GUIDE, REAR	19
-	1	1	1901695-3	STRIP GUIDE, FRONT	18
-	4	4	1-2079383-1	SCR, BHSC, RoHS (M6 X 12)	17
-	1	1	1752360-1	SPACER,HOLD-DOWN	13
-	1	1	240644-1	PLATE, REAR SHEAR	11
-	1	1	690482-3	PLATE, FRONT SHEAR	9
-	1	2	1-1803001-3	ANVIL, COMBINATION, END FEED	8
-	1	1	1-2217206-4	BLADE, SLUG	7
-	-	-	-	-	6
-	1	1	7-240641-6	SPACER	5
-	1	1	238011-2	BLOCK, CRIMPER SPACER	4
-	1	2	2-1633961-3	CRIMPER, INSULATION F PREMIUM	3
-	1	1	1-455888-1	SPACER, CRIMPER	2
-	1	2	2-456405-5	CRIMPER, WIRE PREMIUM	1
-	77	72	-2	PART NO	ITEM NO

ATLANTIC VERSION
Shown on sheets 1 of 4 & 2 of 4
(Pacific version shown on sheets 3 of 4 & 4 of 4)

DIMENSIONS:		TOLERANCES UNLESS OTHERWISE SPECIFIED:		DWG		CHK		APVD		NAME	
mm	0 PLC ±	1 PLC ±	2 PLC ±	3 PLC ±	4 PLC ±	5 PLC ±	ANGLES	FINISH	DATE	DATE	DATE
									22JAN2013	22JAN2013	22JAN2013
									Y. YIN	G. BAILEY	S. XI
									TE Connectivity Harrisburg, PA 17105-3608		
									Ocean End Feed Applicator		
									SIZE	CAGE CODE	DRAWING NO
									A1	00779	2150311
									CUSTOMER ACCESSIBLE PRODUCTION DRAWING		
									SCALE	SHEET	REV
									1:1	1	B

LOC	DIST	REVISIONS			
P	LTN	DESCRIPTION	DATE	OWN	APVD
A	66	SEE SHEET 1	-	-	-

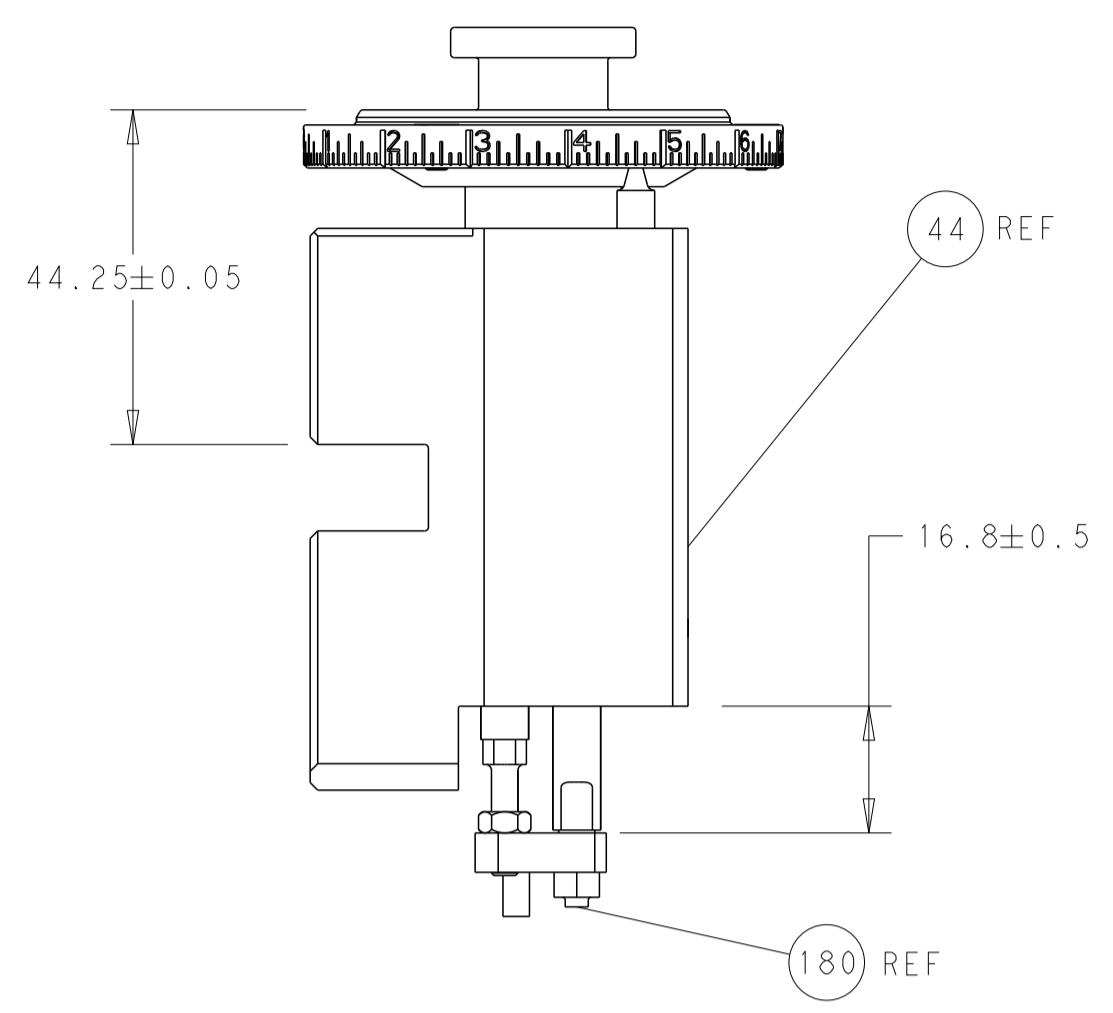

RAM AND HOLDDOWN SET-UP

FEED TYPE

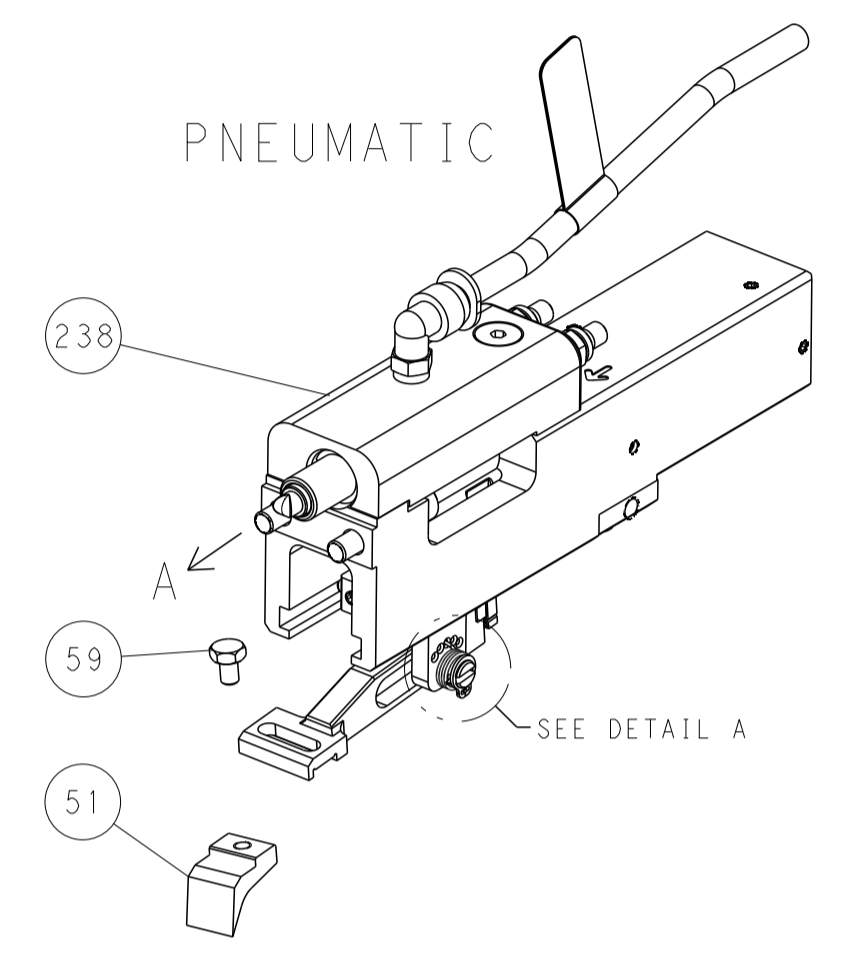

FEED SPRING SETTING POSITION

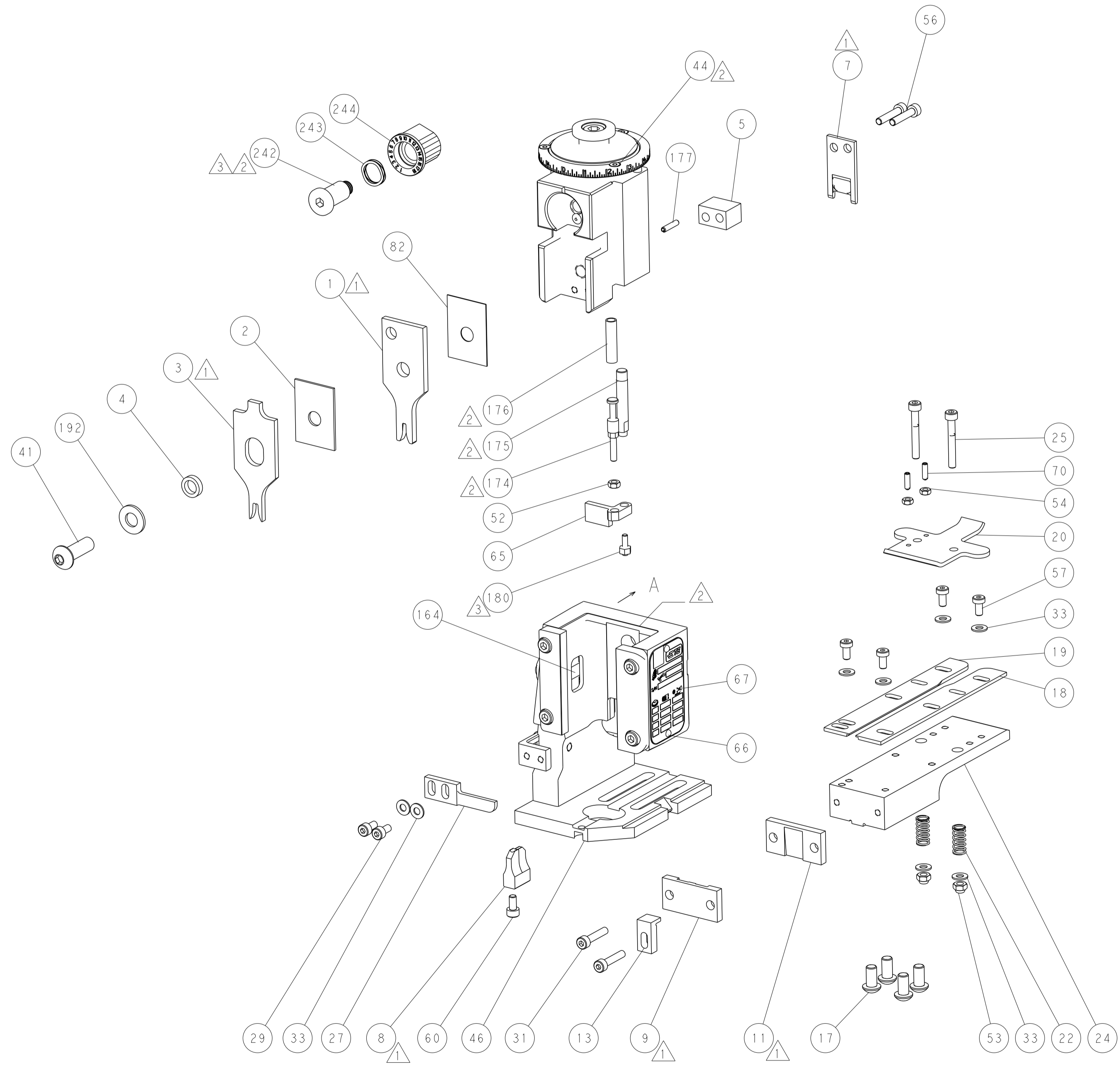
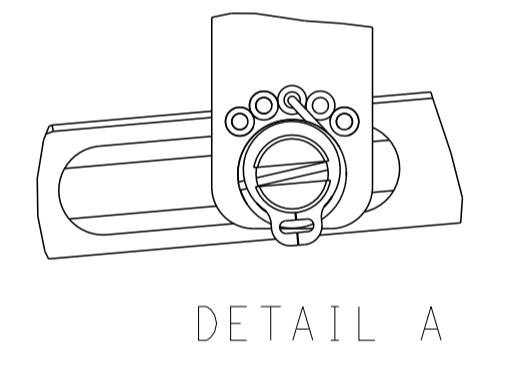

CAM POSITION

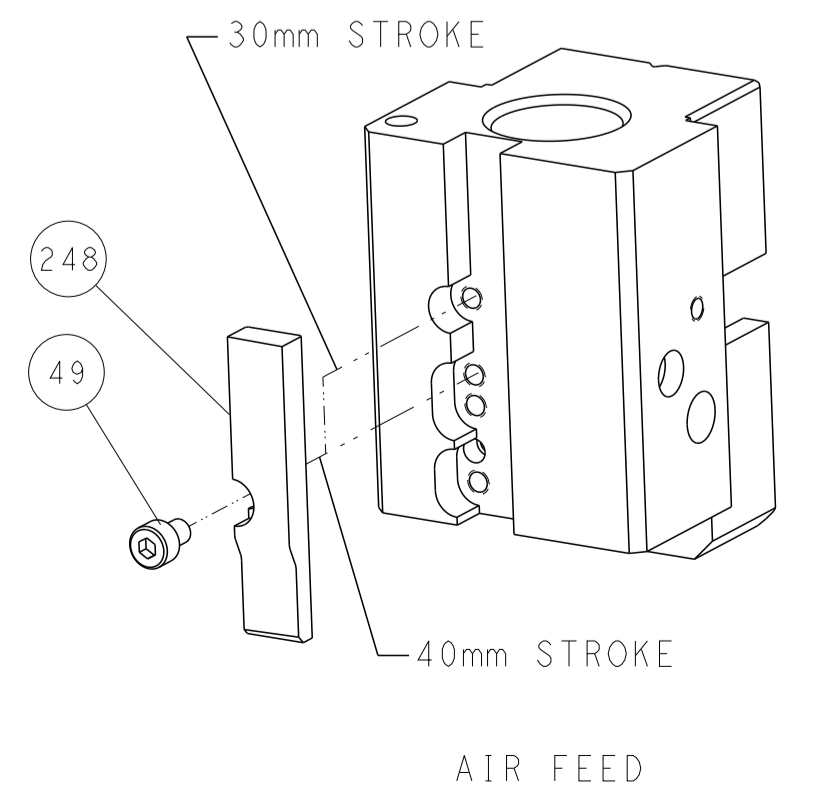

ATLANTIC VERSION
 Shown on sheets 1 of 4 & 2 of 4
 (Pacific version shown on sheets 3 of 4 & 4 of 4)

DIMENSIONS: mm 		TOLERANCES UNLESS OTHERWISE SPECIFIED: 0 PLC ± 1 PLC ± 2 PLC ± 3 PLC ± 4 PLC ± ANGLES ± FINISH		DWN Y. YIN 22JAN2013 CHK G. BAILEY 22JAN2013 APVD S. XI 22JAN2013 NAME Ocean End Feed Applicator SIZE CAGE CODE DRAWING NO RESTRICTED TO A 00779 C=2150311 CUSTOMER ACCESSIBLE PRODUCTION DRAWING SCALE 1:1 SHEET 2 OF 4 REV B	
MATERIAL:		WEIGHT:		DATE: 22JAN2013 DRAWING NO: C=2150311 SHEET: 2 OF 4 REV: B	

THIS DRAWING IS UNPUBLISHED.	RELEASED FOR PUBLICATION		
COPYRIGHT 20 BY TYCO ELECTRONICS CORPORATION. ALL RIGHTS RESERVED.			
PART NUMBER	REVISION	DESCRIPTION	FEED TYPE
2-2150311-2	B	FINE CRIMP HEIGHT ADJUST	PNEUMATIC
7-2150311-7	A	CRIMP TOOLING KIT	-

PACIFIC VERSION TERMINATOR INTERFACE ADAPTER

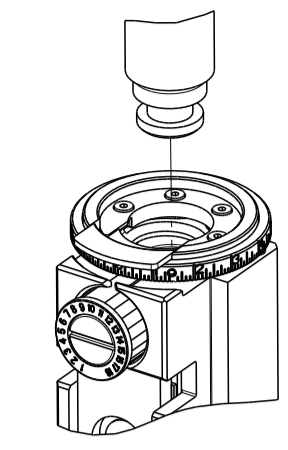

APPLICATOR DATA		
CRIMP	SIZE	TYPE
WIRE	2.03 mm (.080)	F
INSUL	3.56 mm (.140)	F
APPL INSTRUCTIONS 408-35043		

TERMINAL DATA: LEAR TERMINAL		TE CRIMP SPECIFICATION	
TERMINAL NAME: TERMINAL			
WIRE STRIP LENGTH 4.75-5.35 mm (.187-.211 IN)		INSULATION DIAMETER RANGE Ø 2.92 mm MAX (.0115 IN MAX)	
TERMINAL APPLICATION SPECIFICATION		TE SPEC	
TERMINALS APPLIED			
TE TERMINAL	LEAR TERMINAL	TE TERMINAL	LEAR TERMINAL
2114314-1	25697.126.009	2113314-4	25697.213.009
2114314-2	25697.126.142	2113314-5	25697.213.141
2114314-3	25697.126.178	2113314-6	25697.213.178

WIRE SIZE	CRIMP HEIGHT mm [INCH]	CRIMP HEIGHT REFERENCE SETTING
1.00mm2	1.49 +/- 0.05 [.059 +/- .002]	7.8
0.75mm2	1.39 +/- 0.05 [.055 +/- .002]	8.8
0.50mm2	1.29 +/- 0.05 [.051 +/- .002]	10.0



- RECOMMENDED SPARE PARTS
- REFER TO SUPPLIED INSTRUCTION SHEET FOR CLEANING, LUBRICATION AND STORAGE OF APPLICATOR.
- APPLY PART NUMBER 2-23419-6 LOCTITE TO THREADS OF ITEM 242. APPLY PART NUMBER 1-23419-5 LOCTITE TO THREADS OF ITEM 180.
- CRIMP HEIGHT REFERENCE SETTING WAS THE SETTING USED WHEN THE APPLICATOR WAS QUALIFIED AT THE FACTORY. ADJUSTMENT MAY BE NECESSARY WHEN RUNNING APPLICATOR IN THE FIELD.
- TERMINAL PITCH NOT COMPATIBLE WITH MECHANICAL FEED.
- UNLESS SPECIFIED OTHERWISE TORQUE VALUES SHALL BE USED PER DOCUMENT, 101-35000.

***WARNING**
ON INSTALLATION, SET WIRE DISC TO CRIMP HEIGHT REFERENCE SETTING FOR LARGEST WIRE SIZE. CRIMP HEIGHT REFERENCE SETTINGS GREATER THAN THE VALUE SHOWN MAY CAUSE DAMAGE TO THE CRIMP TOOLING. REFER TO THE INSTRUCTION SHEET FOR PROPER SETUP AND ADJUSTMENTS.

PACIFIC VERSION
Shown on sheets 3 of 4 & 4 of 4
(Atlantic version shown on sheets 1 of 4 & 2 of 4)

LOC	DIST	REVISIONS					
A	66	P	LTN	DESCRIPTION	DATE	OWN	APVD
		-		SEE SHEET 1	-	-	-

-	1	2119082-9	CAM, SNAIL, INSULATION ADJUSTMENT	244	
-	1	2079764-1	WASHER, WAVE SPRING, CREST-TO-CREST	243	
3	-	1	2119083-1	RETAINER, INSULATION DIAL	242
-	1	2844940-4	AIR FEED MODULE	238	
-	1	1-18028-0	WASHER, FLAT, REG M8	192	
-	4	2079383-9	SCR, BHSC, RoHS (M6 X 20)	186	
3	-	1	1976055-3	STANDOFF, HOLD-DOWN	180
-	1	6-993111-6	PIN, SLOTTED SPRING 3.0 X 14.0	177	
-	1	8-22280-7	SPRING, COMPRESSION	176	
-	1	1752353-2	GUIDE PIN, HOLDDOWN	175	
-	1	1901680-2	GUIDE PIN, HOLDDOWN	174	
-	REF	994970-2	COUNTER, MAGNETIC	164	
-	1	2119641-2	FEED CAM, AIR FEED	152	
-	1	2168083-8	SCR, SKT HD CAP, RoHS, M4 X 16	144	
-	1	2119655-6	APPLICATOR BASIC ASSEMBLY, EF	141	
-	1	1803518-1	RAM ASSEMBLY, EF PACIFIC	140	
-	1	455888-4	SPACER, CRIMPER	82	
-	1	1803607-4	DOCUMENTATION PACKAGE	71	
-	2	2-18032-2	SCR, SET, FLT PNT, M3 X 10.0	70	
-	1	2119740-1	TAG, IDENTIFICATION	67	
-	2	2168078-1	SCREW, DRIVE, RH, RoHS, 2 x .188	66	
-	1	1976052-1	HOLDDOWN, TERMINAL	65	
-	1	5-18022-5	SCR, HEX HD CAP, M4 X 6.0	59	
-	4	2168400-4	SHCS, LOW HEAD, RoHS, M4 X 8	57	
-	2	2168083-9	SCR, SKT HD CAP, RoHS, M4 X 20	56	
-	2	5018030-1	NUT, HEX, REG, RoHS, M3	54	
-	2	986965-8	NUT, LOCK, HEX, TORQUE (M4)	53	
-	1	1-5018030-0	NUT, HEX, REG, RoHS, M3.5	52	
-	1	2063961-1	FEED FINGER	51	
-	1	18023-9	SCR, SKT HD CAP M4 X 6.0	49	
-	1	1803602-1	SCR, BHSC, RoHS (M8 X 25)	41	
-	8	1-18028-2	WASHER, FLAT, REG M4	33	
-	2	2168083-9	SCR, SKT HD CAP, RoHS, M4 X 20	31	
-	2	2168083-2	SCR, SKT HD CAP, RoHS, M4 X 8.0	29	
-	1	240639-1	STRIPPER (MACHINING)	27	
-	2	1-2168083-5	SCR, SKT HD CAP, RoHS, M4 X 30	25	
-	1	1752371-5	PLATE, STRIP GUIDE	24	
-	2	2-22281-3	SPRING, COMPRESSION	22	
-	1	1803292-4	DRAG	20	
-	1	1901696-3	STRIP GUIDE, REAR	19	
-	1	1901695-3	STRIP GUIDE, FRONT	18	
-	1	1752360-1	SPACER, HOLD-DOWN	13	
3	-	1	240644-1	PLATE, REAR SHEAR	11
3	-	1	690482-3	PLATE, FRONT SHEAR	9
3	1	1	1-1803001-3	ANVIL, COMBINATION, END FEED	8
3	-	1	1-2217206-4	BLADE, SLUG	7
-	-	-	-	6	
-	1	7-240641-6	SPACER	5	
-	1	238011-2	BLOCK, CRIMPER SPACER	4	
3	1	1	2-1633961-3	CRIMPER, INSULATION F PREMIUM	3
-	1	1	1-455888-1	SPACER, CRIMPER	2
3	1	1	2-456405-5	CRIMPER, WIRE PREMIUM	1
-	-	-	-	0	

DIMENSIONS:		TOLERANCES UNLESS OTHERWISE SPECIFIED:		DWG		22JAN2013		OWN	
mm		0 PLC ±		CHK		Y. YIN		TE Connectivity	
Ø		1 PLC ±		G. BAILEY		22JAN2013		Harrisburg, PA 17105-3608	
H		2 PLC ±		APVD		S. XI		NAME	
A		3 PLC ±		S. XI		22JAN2013		Ocean End Feed	
B		4 PLC ±		PRODUCT SPEC				Applicator	
C		5 PLC ±		APPLICATION SPEC					
D		6 PLC ±		SIZE		CAGE CODE		DRAWING NO	
E		ANGLES		WEIGHT		A1		00779	
F		FINISH		CUSTOMER ACCESSIBLE PRODUCTION DRAWING		SCALE		1:1	
G				SHEET		3		OF 4	
H				REV		B			

LOC	DIST	REVISIONS			
P	LTR	DESCRIPTION	DATE	DNW	APVD
A	66	SEE SHEET 1			

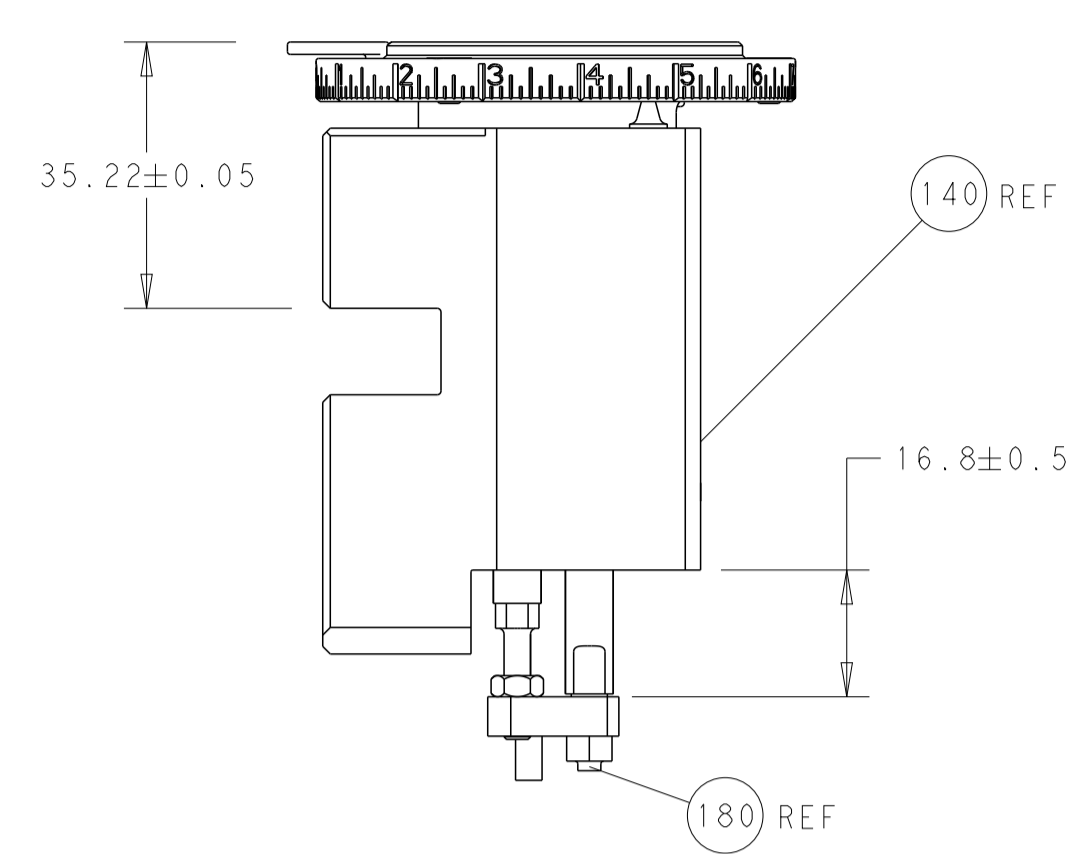

RAM AND HOLDDOWN SET-UP

FEED TYPE

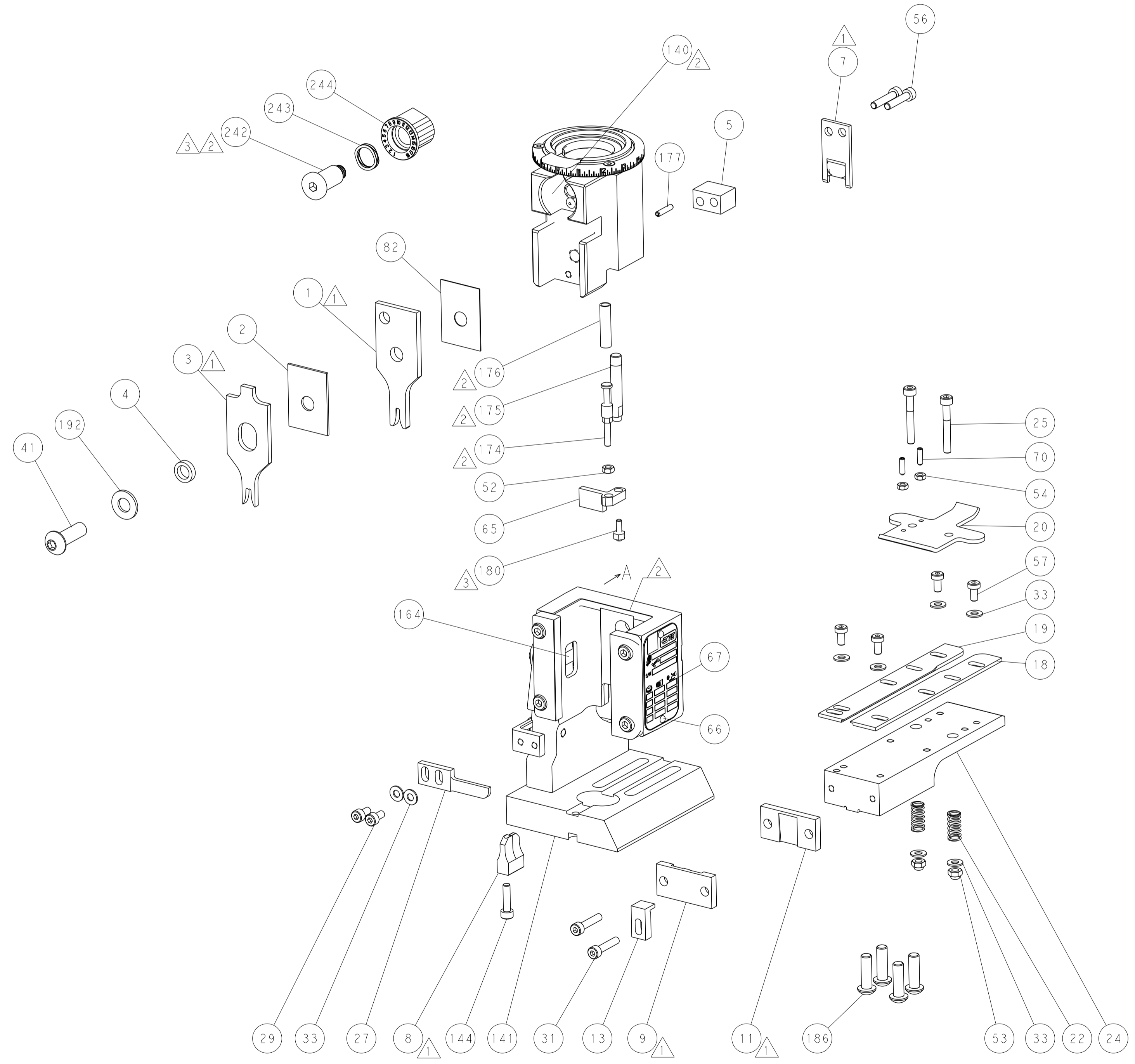
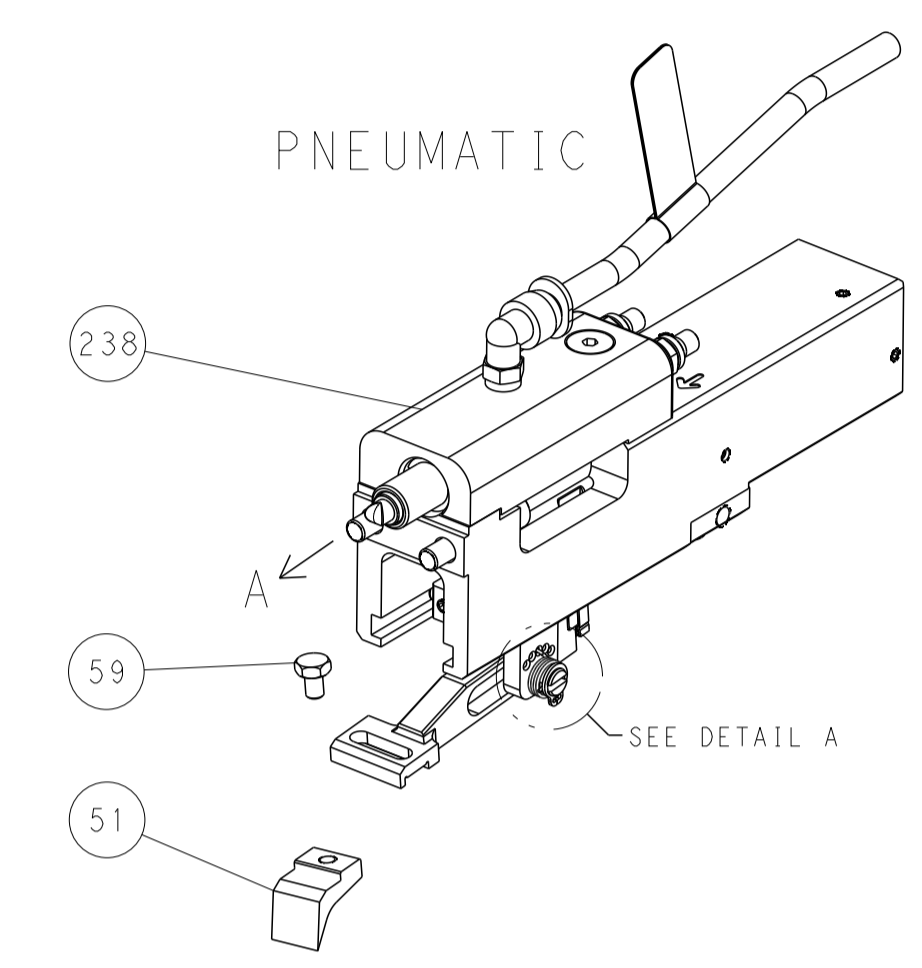

CAM POSITION

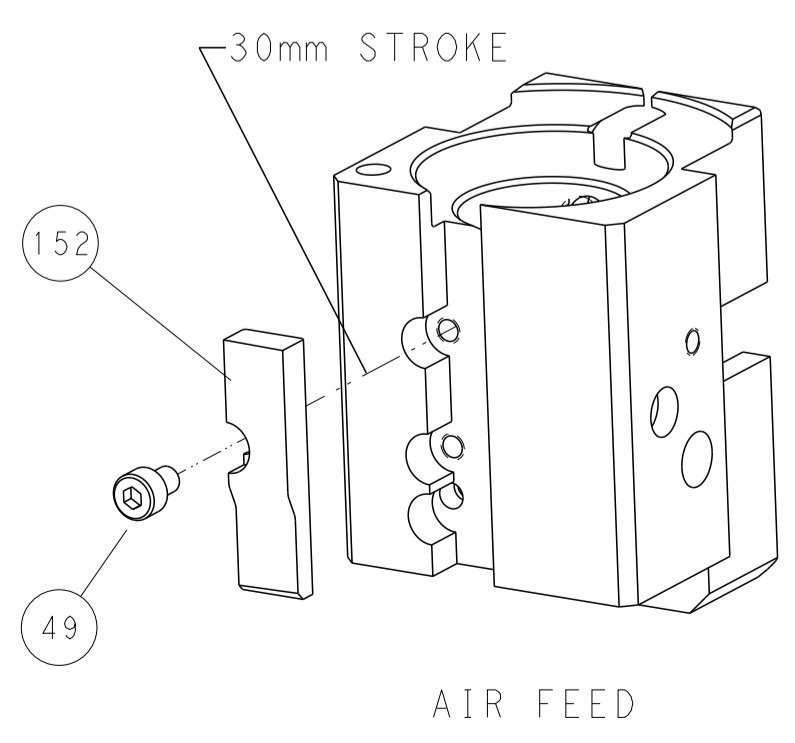

PACIFIC VERSION
 Shown on sheets 3 of 4 & 4 of 4
 (Atlantic version shown on sheets 1 of 4 & 2 of 4)

DIMENSIONS:		TOLERANCES UNLESS OTHERWISE SPECIFIED:		DWG Y. YIN 22JAN2013		CHK G. BAILEY 22JAN2013		APVD S. XI 22JAN2013		NAME	
mm	0 PLC ±	1 PLC ±	2 PLC ±	3 PLC ±	4 PLC ±	ANGLES ±	STE TE Connectivity Harrisburg, PA 17105-3608		Ocean End Feed Applicator		
MATERIAL	FINISH	WEIGHT	A 00779 C=2150311		SCALE 1:1		SHEET 4 OF 4		REV B		