

μPD166031AT1U

INTELLIGENT POWER DEVICE

R07DS1308EJ0100

Rev.1.00

Oct. 30, 2015

1. Overview

1.1 Description

Family:

μPD166031AT1U is part of 2nd Generation Intelligent Power Devices (IPD). They are N-channel high-side switches with charge pump, voltage controlled input, diagnostic feedback with proportional load current sense and embedded protection function. Family includes up to 14 devices depending on on-state resistance, package and channel number combination.

Scalability:

Variety of on-state resistance combined with standardized package on pin-out give user high flexibility for unit design depending on target load.

Robustness:

Because of advanced protection method, 2nd Generation Intelligent Power Devices achieve high robustness against long term and repetitive short circuit condition.

1.2 Features

- Built-in charge pump
- 3.3V compatible logic interface
- Low standby current
- Short circuit protection
 - Shutdown by over current detection
 - Power limitation protection by over load detection (Power limitation: current limitation with delta Tch control)
 - Absolute Tch over temperature protection
- Built-in diagnostic function
 - Proportional load current sensing
 - Defined fault signal in case of abnormal load condition
- Loss of ground protection
- Under voltage lock out
- Active clamp operation at inductive load switch off
- Cross current protection in case of H-bridge high side usage
- AEC Qualified
- RoHS compliant

1.3 Application

- Light bulb switching from 55W to 65W according to on-state resistance
- Switching of all types of 14V DC grounded loads, such as LED, inductor, resistor and capacitor
- Power supply switch, fail-safe switch of 14V DC grounded system

Note: The information contained in this document is the one that was obtained when the document was issued, and may be subject to change.

2. Ordering Information

Part No.	Nick name	Lead plating	Packing	Package
UPD166031AT1U-E1-AY	NHS010A(A)	Pure Matte Sn	Tape 2500 p/reel	TO252-7

Note: Part No. and Nick name are tentative and might change at anytime without notice.

2.1 Nick name

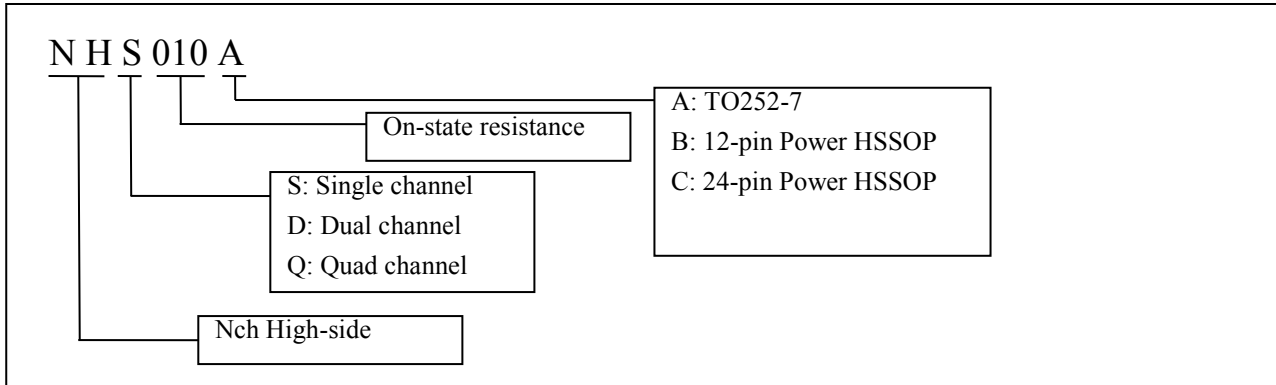

3. Specification

3.1 Block Diagram

3.1.1 Nch High-side Single Device

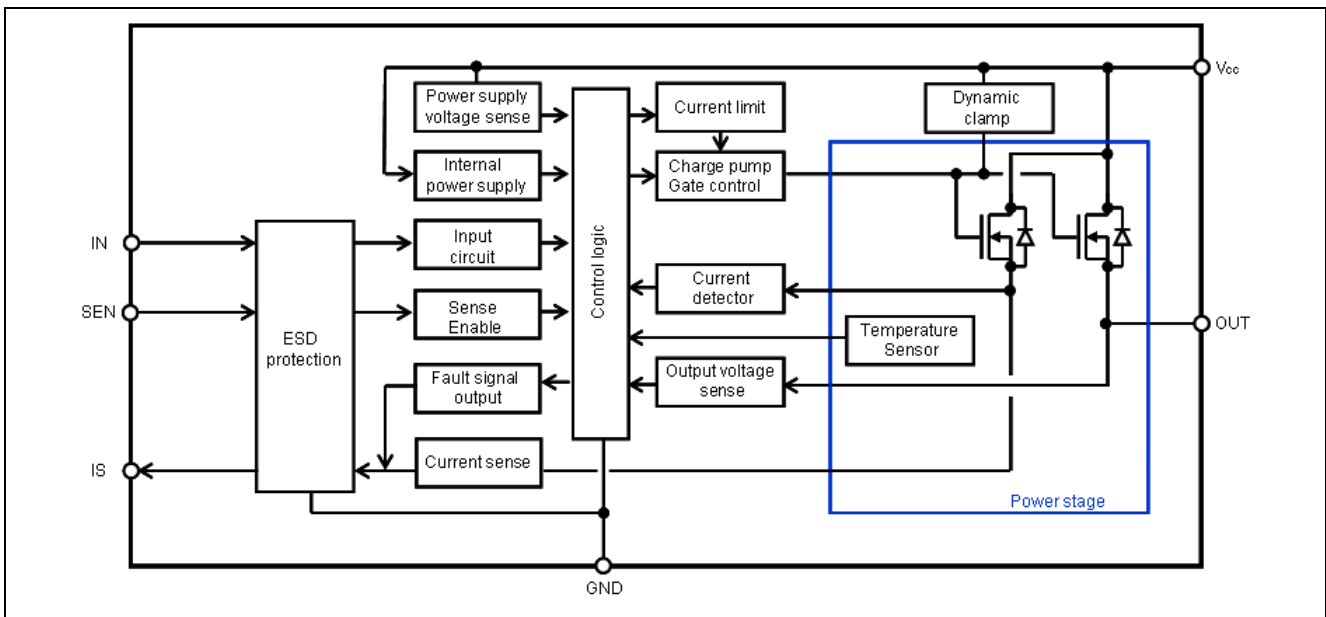

Voltage and Current Definition

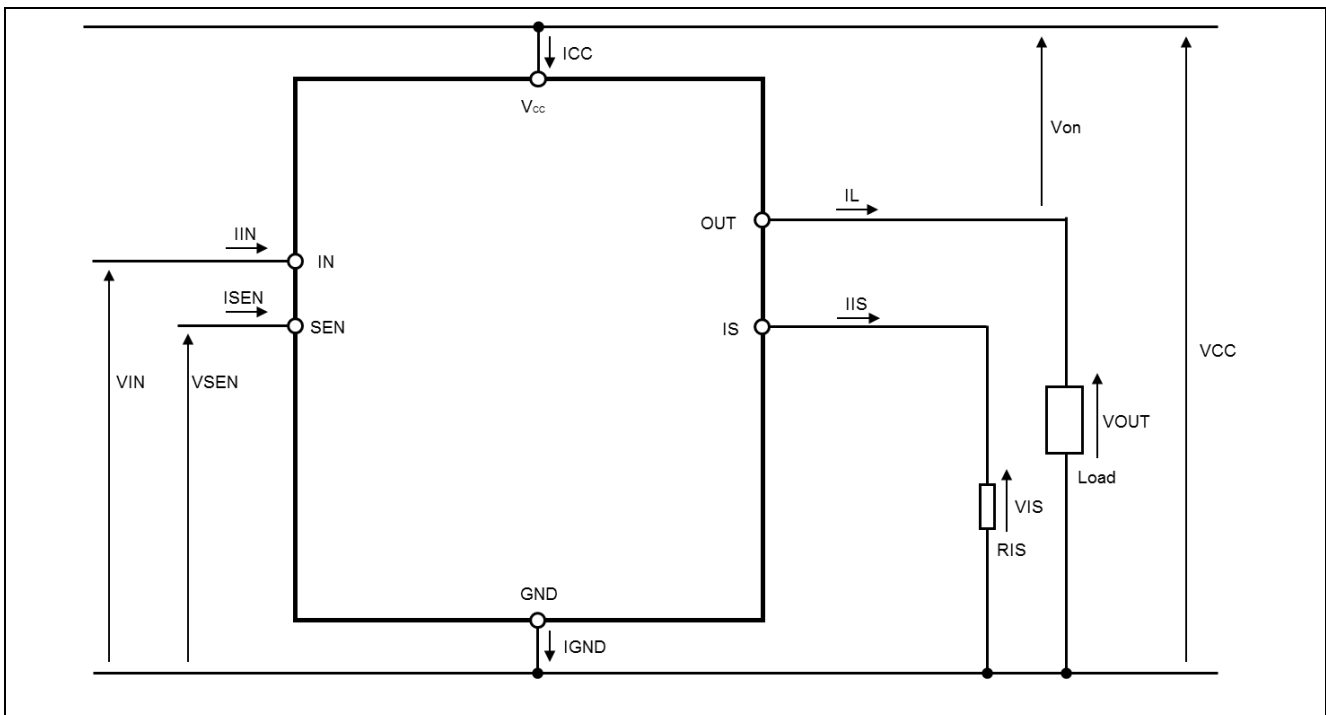

3.2 Pin Configuration

3.2.1 TO252-7 Pin Configuration

Pin No.	Terminal Name
1	OUT
2	GND
3	IN
4, Tab	VCC
5	IS
6	SEN
7	OUT

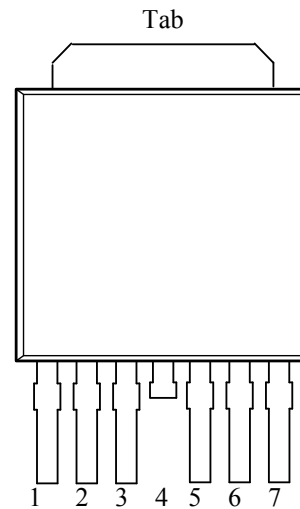

Pin function

Terminal Name	Pin function	Recommended connection
GND	Ground connection	Connected to GND through a 100 Ω resistor or a diode for reverse current protection Refer chapter 6.
IN	Input signal	Connected to MCU port through 2k-50K serial resistor.
IS	Current sense and Diagnosis output signal	Connected to GND through a 0.67K-5K resistor. Not connect if this pin is not used.
SEN	Sense enable input	Connected to MCU port through 2k-50K serial resistor. Not connect if this pin is not used.
OUT	Protected high-side power output	Connected to load with small 50-100nF capacitor in parallel.
VCC	Positive power supply for logic supply as well as output power supply	Connected to battery voltage with small 100nF capacitor in parallel.

3.3 Absolute Maximum Ratings

Ta=25°C, unless other specified

Parameter	Symbol	Rating	Unit	Test Condition		
Vcc Voltage	V _{CC}	28	V			
Vcc Voltage at reverse battery condition	-V _{CC}	-16	V	RL=2Ω, t<2min, RIN=2kΩ, RSEN=2kΩ, RIS=1kΩ, RGND=100Ω		
GND Reverse current at reverse battery condition	I _{GND(Rev)}	200	mA	RL=2Ω, t<2min		
Vcc voltage under Load Dump condition	V _{load dump}	42	V	RI=1Ω, RL=2Ω, RIS=1kΩ, RIN=2kΩ, RSEN=2kΩ, RGND=100Ω, td=400ms		
Load Current	I _L	Self limited	A			
Total power dissipation for whole device (DC)	P _D	1.85	W	Ta=85°C, Device on 50mm×50mm×1.5mm epoxy PCB FR4 with 6 cm ² of 70 μm copper area		
Voltage at IN pin	V _{IN}	-2 ~ 16	V	DC RIN=2kΩ		
		-16	V	At reverse battery condition, t<2min, RIN=2kΩ, RSEN=2kΩ		
IN pin current	I _{IN}	10	mA	DC		
Voltage at IS pin	V _{IS}	V _{CC}	V	DC RIS=1kΩ		
		-16	V	At reverse battery condition, t<2min, RL=2Ω, RIS=1kΩ		
IS Reverse current at reverse battery condition	I _{IS(Rev)}	-30	mA	At reverse battery condition, t<2min, RL=2Ω		
Voltage at SEN pin	V _{SEN}	-2 ~ 16	V	DC RSEN=2kΩ		
		-16	V	At reverse battery condition, t<2min RIN=2kΩ, RSEN=2kΩ		
SEN pin current	I _{SEN}	10	mA	DC		
Channel Temperature	T _{ch}	-40 to +150	°C			
Storage Temperature	T _{stg}	-55 to +150	°C			
ESD susceptibility	V _{ESD}	2000	V	HBM	AEC-Q100-002 std. R=1.5kΩ, C=100pF	All pin
		4000	V		IEC61000-4-2 std. R=330Ω, C=150pF, 100nF at VCC and OUT	VCC, OUT
		200	V	MM	AEC-Q100-003 std. R=0Ω, C=200pF	
Inductive load switch-off energy dissipation single pulse	EAS	170	mJ	VCC=13.5V, T _{ch,start} <150°C, RL=2Ω		
Inductive load switch-off energy dissipation repetitive pulse	EAR	95	mJ	VCC=13.5V, T _{ch,start} =85°C, RL=2Ω		

Remark) All voltages refer to ground pin of the device

3.4 Thermal Characteristics

Parameter	Symbol	Min	Typ	Max	Unit	Test Condition
Thermal characteristics	Rth(ch-a)		35		°C/W	According to JEDEC JESD51-2, -5, -7 on FR4 2s2p board
	Rth(ch-c)		1.0		°C/W	

3.5 Electrical Characteristics

Operation function

Tch=-40 to 150°C, Vcc=7 to 18V, unless otherwise specified

Parameter	Symbol	Min	Typ	Max	Unit	Test Condition	
Operating Voltage	V _{CC}	4.5		28	V	VIN=4.5V, RL=2Ω	
Operating current	I _{GND}		2.2	4	mA	VIN=4.5V	
Output Leakage current	I _{L(off)}			0.5	μA	Tch=25°C	VCC=13.5V, VIN=0V, VSEN=0V, VIS=0V, VOUT=0V, VGND=0V
				3		Tch=-40~125°C	
Standby current	I _{CC(off)}			0.5	μA	Tch=25°C	VCC=13.5V, VIN=0V, VSEN=0V, VIS=0V, VOUT=0V, VGND=0V
				1.5		Tch=-40~85°C	
On-state resistance	R _{on}		10		mΩ	Tch=25°C	IL=6.8A
				20		Tch=150°C	
Low level IN pin voltage	V _{IL}			0.8	V		
High level IN pin voltage	V _{IH}	2.5			V		
Low level IN pin current	I _{IL}	2		25	μA	VIN=0.8V	
High level IN pin current	I _{IH}	2		25	μA	VIN=2.5V	
Clamping IN pin voltage ¹⁾	V _{ZIN}	5	6		V		
Low level SEN pin voltage	V _{SENL}			0.8	V		
High level SEN pin voltage	V _{SENH}	2.5			V		
Low level SEN pin current	I _{SENL}	2		25	μA	VSEN=0.8V	
High level SEN pin current	I _{SENH}	2		25	μA	VSEN=2.5V	
Clamping SEN pin voltage ¹⁾	V _{ZSEN}	5	6		V		
Under voltage shutdown	V _{CC(UV)}			4.5	V		
Under voltage restart	V _{CC(Cpr)}			5.0	V		
Turn on time	t _{on}			200	μs	VCC=13.5V, RL=2Ω	
Turn on delay time	t _{d(on)}			100	μs		
Turn off time	t _{off}			200	μs		
Turn off delay time	t _{d(off)}			150	μs		
Slew rate on	dV/dton			1.5	V/μs		
Slew rate off	-dV/dtoff			1.5	V/μs		
Switching drift ¹⁾	ton-toff	-50		+50	μs	Vcc = 9 to 18V drift from Vcc=13.5V, Tch=-40 to 150°C drift from Tch=25°C ton; Vout=Vcc-1.5V after input signal active	
Turn on energy loss ¹⁾	E _{on}		1.2	2.4	mJ	VCC=13.5V, Tch=25°C, RL=2Ω	
Turn off energy loss ¹⁾	E _{off}		1.2	2.4	mJ		
Driving capability ¹⁾	Dr(cap)	118			mΩ	Tch=25°C, VCC=8~16V	
		150				Tch=105°C, VCC=8~16V	

Remark) All voltages refer to ground pin of the device

1) not subjected production test, guaranteed by design

Protection function

Tch=-40 to 150°C, Vcc=7 to 18V, unless otherwise specified

Parameter	Symbol	Min	Typ	Max	Unit	Test Condition	
Over current detection current	IL(SC)	72	121		A	VCC=13.5V, Von=5V, Tch=25°C	
Current limitation under power limitation toggling	IL(CL)		53		A	VCC=13.5V	
Current limitation under absolute thermal toggling	IL(TT)		21		A	VCC=13.5V	
Current limitation trigger threshold during turn-on	Von(CL1)		2.0		V	VCC=13.5V	
Current limitation trigger threshold during on-state	Von(CL2)		0.3		V	VCC=13.5V	
Current limitation trigger time after input signal positive slope	td(CL)		500		μs	VCC=13.5V	
Absolute thermal shutdown temperature	aTth	150			°C		
Thermal hysteresis for absolute thermal toggling	aTth,hys		20		°C		
Power limitation thermal shutdown temperature	dTth		50		°C		
Power limitation restart temperature	dTth,rest art		25		°C		
Output clamp at inductive load switch off	Von,clamp	30		40	V	VCC=13.5V, IL=40mA, Tch=25°C	
Output current while GND disconnection	IL(GND)			1	mA	IIN=0A, ISEN=0A, IGND=0A, IIS=0A	
Output voltage drop at reverse battery condition	Vds(rev)			0.9	V	Tch=25°C	VCC=-13.5V, RL=2Ω
				0.7		Tch=150°C	

Remark) All voltages refer to ground pin of the device

Diagnosis function

Tch=-40 to 150°C, Vcc=7 to 18V, VIN=4.5V, VSEN=4.5V, unless otherwise specified

Parameter	Symbol	Min	Typ	Max	Unit	Test Condition
Current sense ratio	KILIS	6000	7500	9000		IL=7A
		5250	7500	9750		IL=1.4A
Current sense drift depend on temperature	dKILIS	-15		15	%	VCC=13.5V, Tch,start=25°C, RL=2Ω
Sense current offset current	lis,offset			2	μA	IL<10mA
Sense current leakage current	lis,dis			1	μA	VIN=0V, VSEN=0V
Sense current under fault condition	lis,fault	3		9.5	mA	VCC=13.5V, RIS=0.67kΩ
		3.5		9		VCC=13.5V, RIS=1kΩ
		3.5		5.5		VCC=13.5V, RIS=2kΩ
Minimum output current for current sense output	IL(CSE)	10		100	mA	IIS>5μA
Open load detection threshold at off-state	VOUT(OL)	2.0		5.0	V	VIN=0V, Tch = -40~105°C
OUT terminal current at Open load condition	IOUT(OL)	-1.0			μA	VIN =0V
Open load detection delay after input negative slope	tdop		300		μs	VIN=4.5V to 0V, VOUT>VOUT(OL)

Remark) All voltages refer to ground pin of the device

Diagnosis function

Tch=-40 to 150°C, Vcc=7 to 18V, VIN=4.5V, VSEN=4.5V, unless otherwise specified

Parameter	Symbol	Min	Typ	Max	Unit	Test Condition
Sense current settling time after input signal positive slope	tsis(on)			250	μs	VCC=13.5V, VIN=0V to 4.5V, IL/IIS=KILIS, RL=2Ω
Sense current settling time after input signal negative slope ¹⁾	tsis(off)			10	μs	VIN=4.5V to 0V
Sense current settling time after sense enable during on-state ¹⁾	tssen(on)			20	μs	VSEN=0V to 4.5V, RL=2Ω
Sense current settling time after sense disable during on-state ¹⁾	tssen(off)			20	μs	VSEN=4.5V to 0V, RL=2Ω
Sense current settling time during on-state ¹⁾	tsis(LC)			20	μs	RL=2Ω to 1Ω
Fault signal delay after over current detection ¹⁾	tdsc(fault)			10	μs	VIN=0V to 4.5V, IL=IL(SC)
Fault signal delay after power limitation valid ¹⁾	tdpl(fault)			10	μs	Von>Von(CL1)
Fault signal delay after power limitation invalid ¹⁾	tdpl(off)			30	μs	Von<Von(CL1)
Fault signal delay after absolute thermal shutdown ¹⁾	tdot(fault)			10	μs	IIS→IIS,fault
Fault signal delay after open load detection at off-state ¹⁾	tdop(fault)			10	μs	VIN=0V, VOUT>VOUT(OL)
Fault signal delay after input negative slope ¹⁾	tdoff(fault)			10	μs	VIN=4.5V to 0V

Remark) All voltages refer to ground pin of the device

1) not subjected production test, guaranteed by design

3.6 Feature Description

3.6.1 Driving Circuit

The high-side output is turned on, if the input pin is over V_{IH} . The high-side output is turned off, if the input pin is open or the input pin is below V_{IL} . Threshold is designed between V_{IH} min and V_{IL} max with hysteresis. IN terminal is pulled down with constant current source.

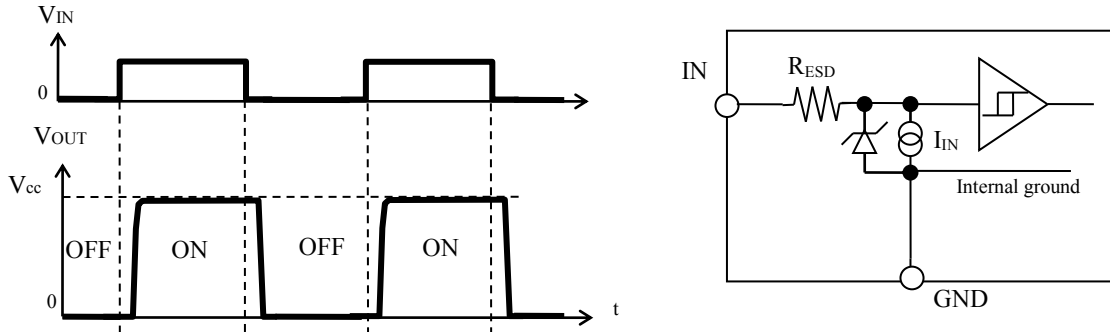

Switching a resistive load

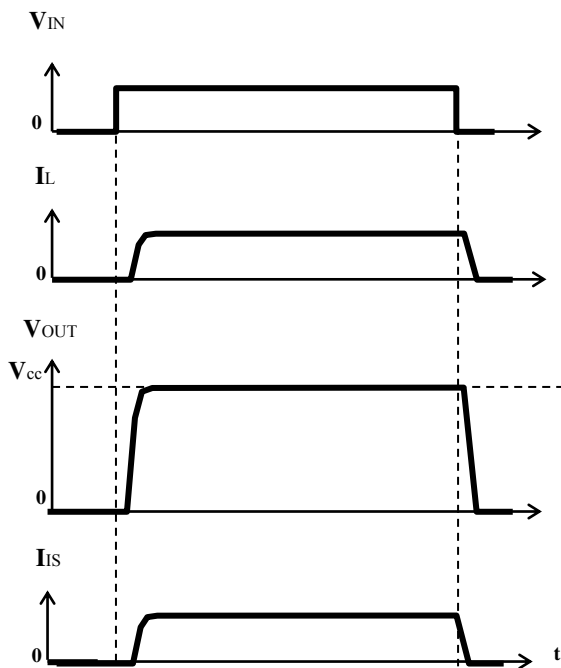

Switching lamps

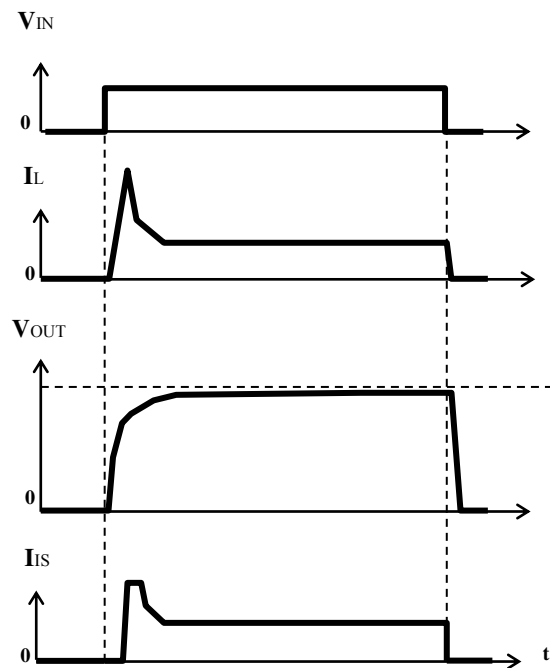

Switching an inductive load

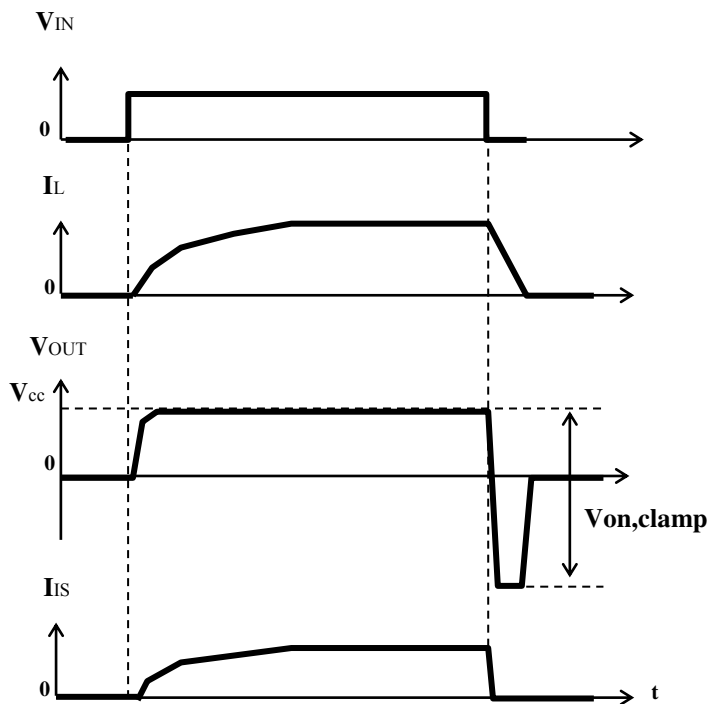

The dynamic clamp circuit works only when the inductive load is switched off. When the inductive load is switched off, the voltage of OUT falls below 0V. The gate voltage of SW1 is then nearly equal to GND. Next, the voltage at the source of SW1 (= gate of output MOS) falls below the GND voltage.

SW1 is turned on, and the clamp diode is connected to the gate of the output MOS, activating the dynamic clamp circuit.

When the over-voltage is applied to VCC, the gate voltage and source voltage of SW1 are both nearly equal to GND. SW1 is not turned on, the clamp diode is not connected to the gate of the output MOS, and the dynamic clamp circuit is not activated.

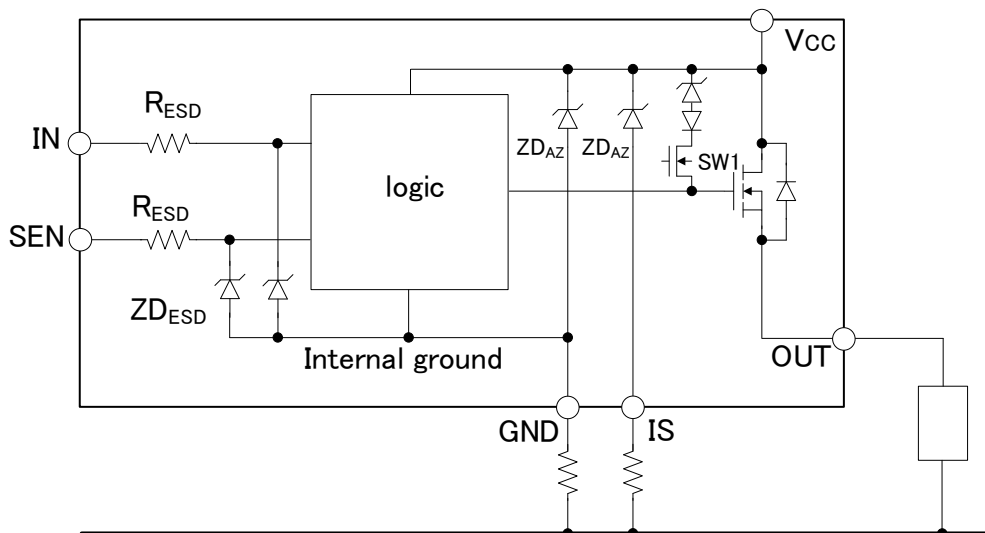

3.6.2 Device behavior at over voltage condition

In case of supply voltage greater than $V_{load\ dump}$, logic part is clamped by ZD_{AZ} (35V min). And current through of logic part is limited by external ground resistor. In addition, the power transistor switches off in order to protect the load from over voltage. Permanent supply voltage than $V_{load\ dump}$ must not be applied to VCC.

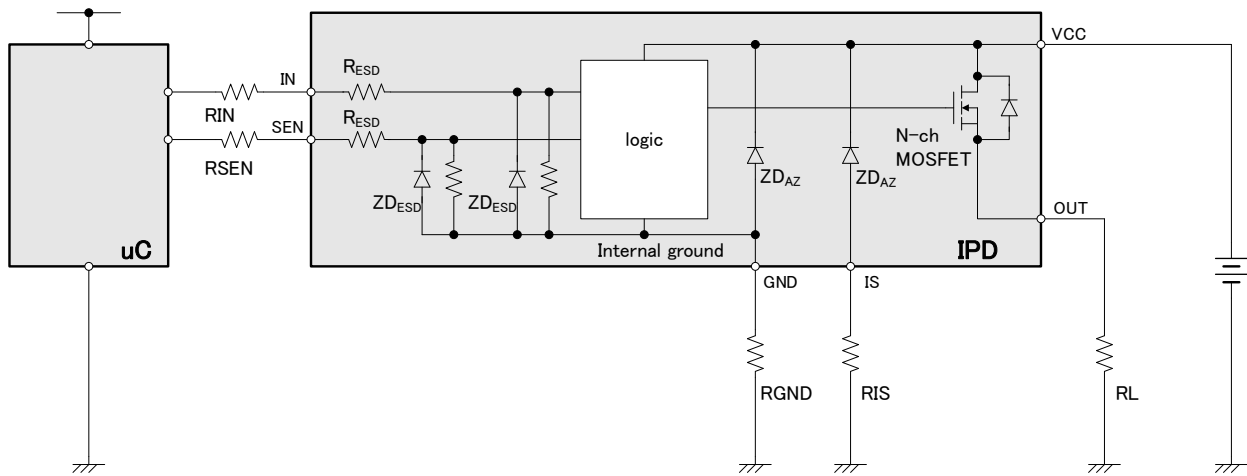

3.6.3 Device behavior at low voltage condition

If the voltage supply (V_{CC}) goes down under $V_{CC}(Uv)$, the device outputs shuts down. If voltage supply (V_{CC}) increase over $V_{CC}(Cpr)$, the device outputs turns back on automatically. The device keeps off state after under voltage shutdown. The IS output is cleared during off-state.

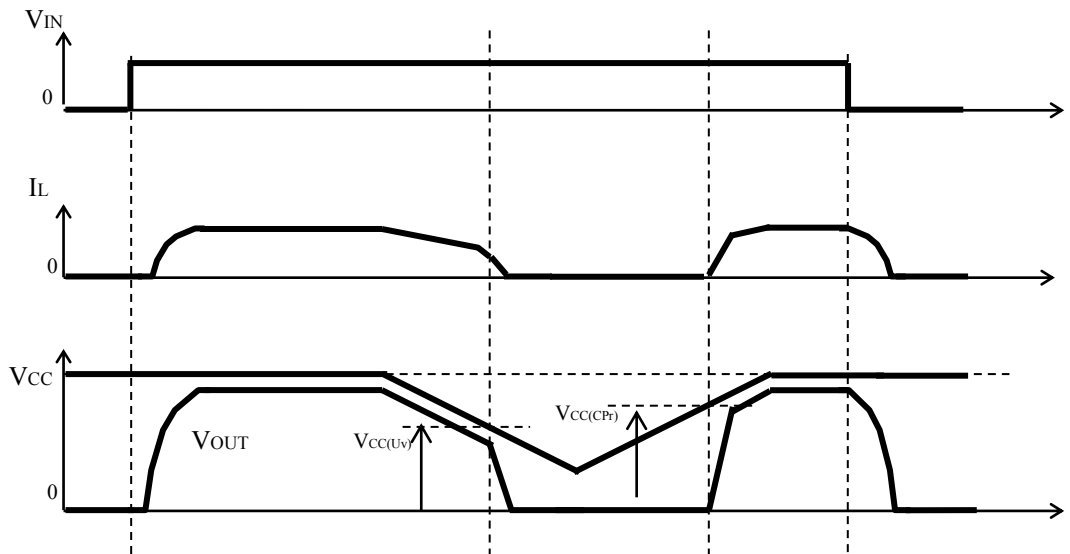

3.6.4 Loss of Ground protection

In case of complete loss of the device ground connection, but connected load ground, the device securely changes to off if V_{IN} was initially greater than V_{IH} state or keeps off state if V_{IN} was initially lower than V_{IL} state.

In case of device loss of ground, IN and SEN terminal will/ could/ might be at VCC voltage.

3.6.5 Short circuit protection

Turn-on in an over load condition including short circuit condition

The device shuts down automatically when condition (a) is detected. The sense pin output Iis,fault. Shutdown is latched until the next reset via input pin. The device shuts down automatically when condition (b) is detected. The device restarts automatically in power limitation mode. The device shuts down automatically when condition (c) is detected and restarts automatically in absolute thermal toggling mode. The device starts current limitation when (d) is detected. The sense pin output Iis,fault during power limitation mode or thermal toggling mode.

- (a) $I_L > I_L(SC)$
- (b) $\Delta T_{ch} > \Delta T_{th}$
- (c) $T_{ch} > aT_{th}$
- (d) $V_{on} > V_{on}(CL1)$ after $t_d(CL)$

Over load condition including short circuit condition during on-state

The device runs automatically into power limitation mode when condition (a) is detected once after $V_{on} < V_{on}(CL2)$. The device shuts down automatically when condition (b) is detected. The device restarts automatically in power limitation mode. The device shuts down automatically when condition (c) is detected and restarts automatically in absolute thermal toggling mode. The sense pin output Iis,fault during power limitation mode or thermal toggling mode.

- (a) $V_{on} > V_{on}(CL2)$
- (b) $\Delta T_{ch} > \Delta T_{th}$
- (c) $T_{ch} > aT_{th}$

Power limitation control

Current limitation control with $I_L(CL)$ when auto restart from ΔT_{ch} protection.

During the current limitation operation and $V_{on} > V_{on}(CL1)$, the sense pin outputs Iis,fault. Even auto restart from ΔT_{ch} protection, if $V_{on} < V_{on}(CL2)$ depends on short circuit impedance condition, the device does not operate as current limitation with $I_L(CL)$. In this case, the sense pin output sense current at on-state, Iis,fault at off-state during toggling operation with power limitation mode.

Absolute thermal toggling

Current limitation control with $I_L(TT)$ when auto restart from absolute T_{ch} protection.

During the current limitation operation and $V_{on} > V_{on}(CL1)$, the sense pin outputs Iis,fault. Even auto restart from absolute T_{ch} protection, if $V_{on} < V_{on}(CL2)$ depends on short circuit impedance condition, the device does not operate as current limitation with $I_L(TT)$. In this case, the sense pin output sense current at on-state, Iis,fault at off-state during toggling operation with thermal toggling mode.

delta Tch

Junction temperature differences between thermal sensor of power area and thermal sensor of control area.

State transition diagram

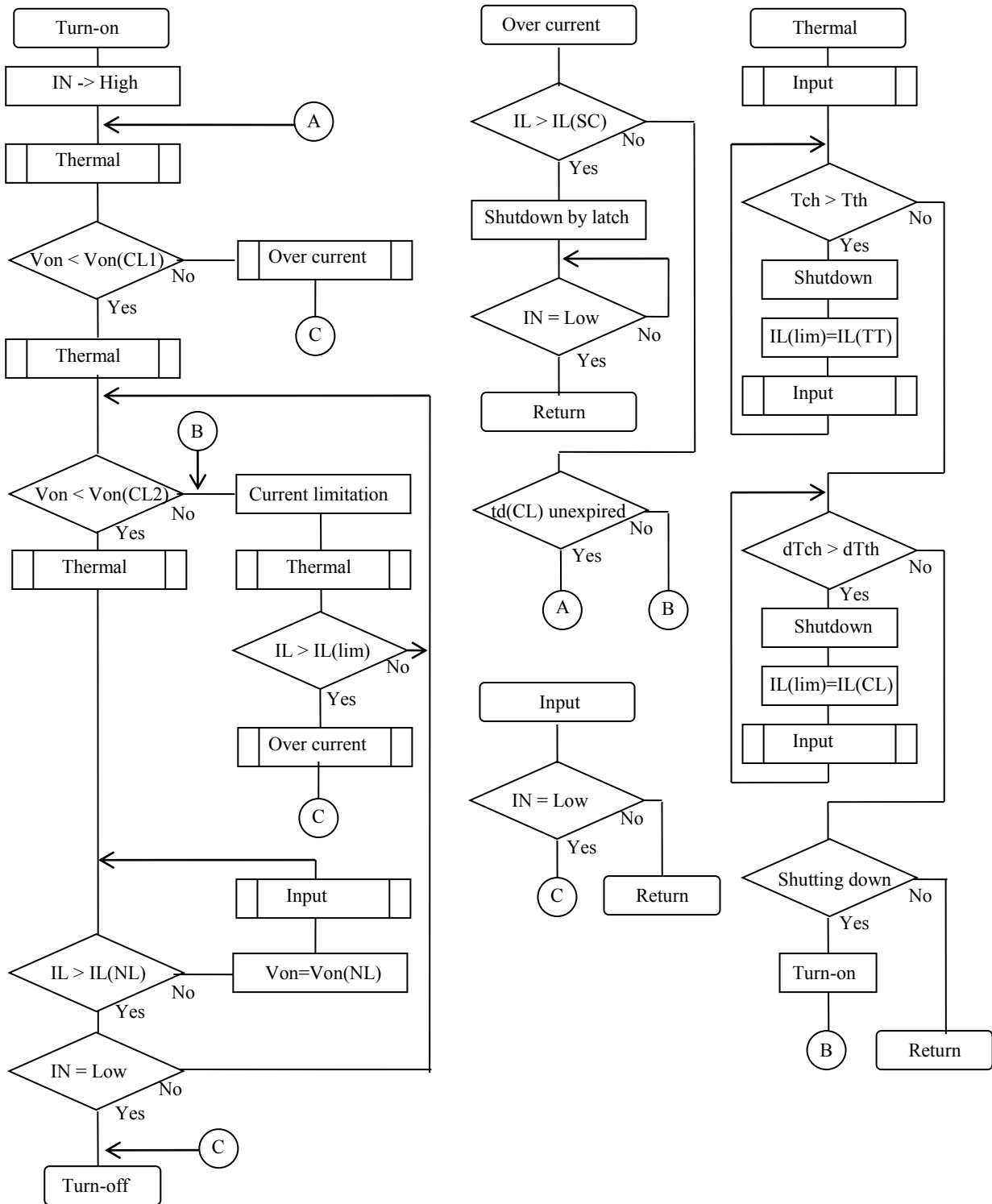

Turn-on in an over load condition including short circuit condition

(a) $IL > IL(SC)$

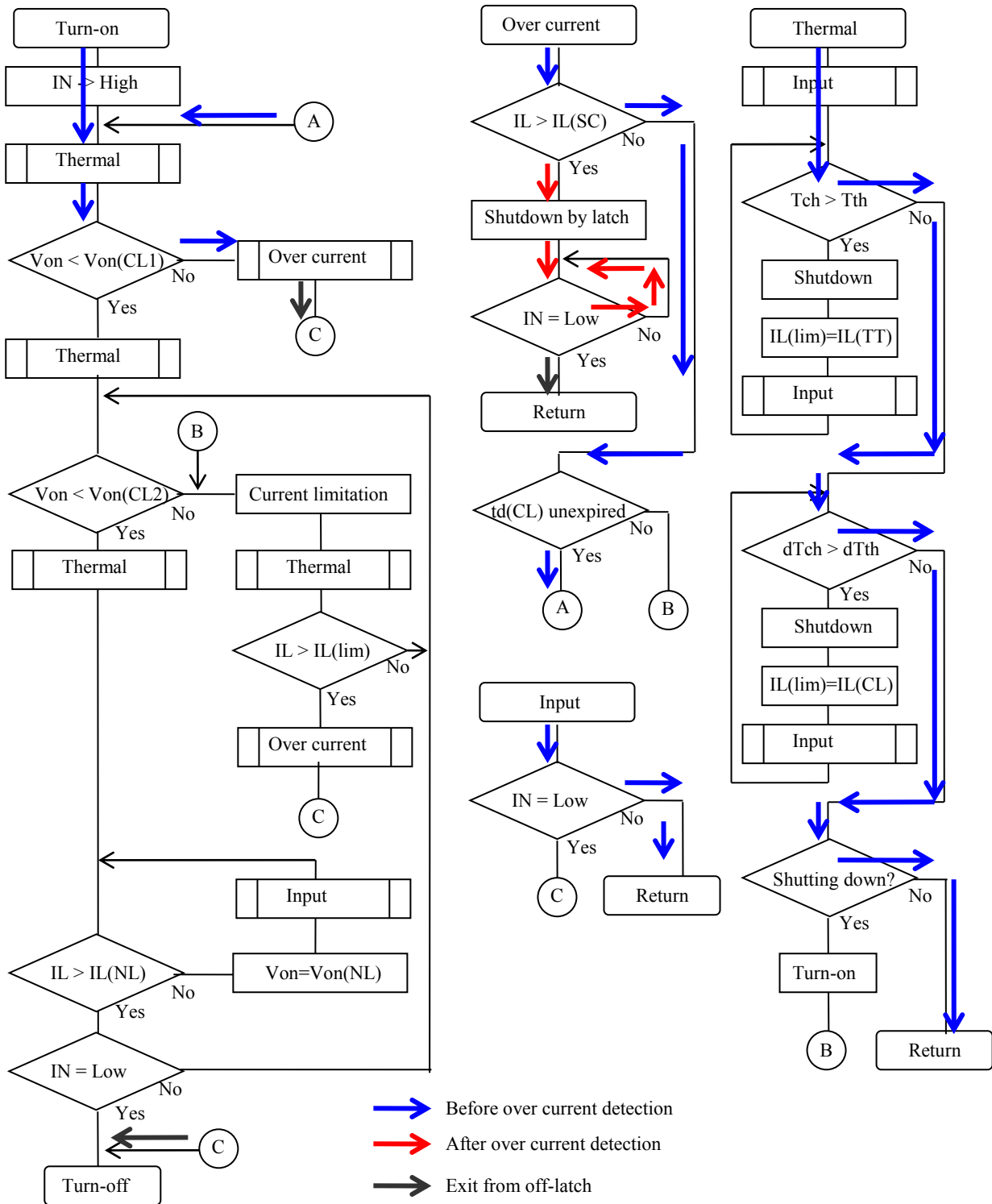

Turn-on in an over load condition including short circuit condition

(b) $\Delta T_{ch} > \Delta T_{th}$

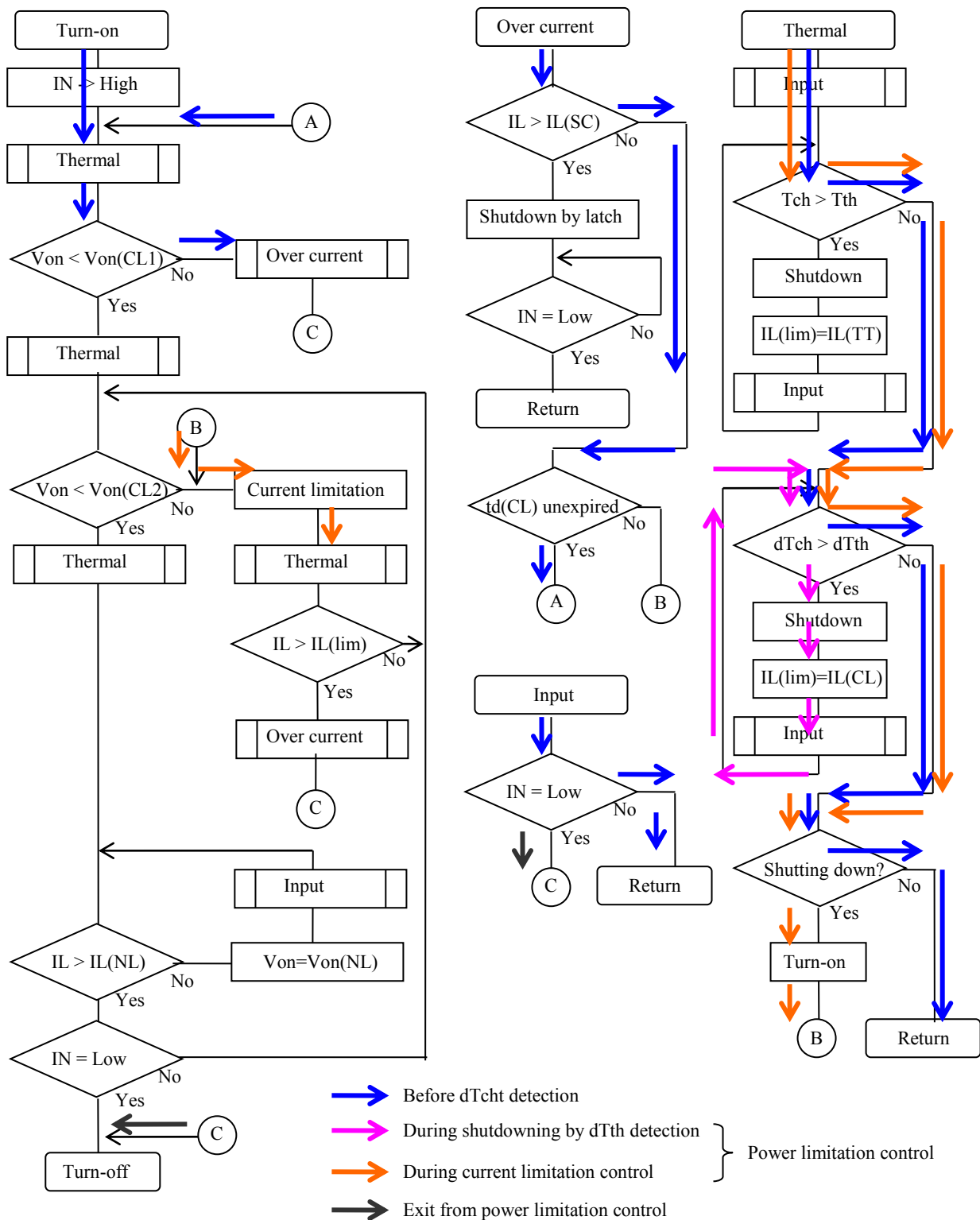

Turn-on in an over load condition including short circuit condition

(c) $T_{ch} > aT_{th}$

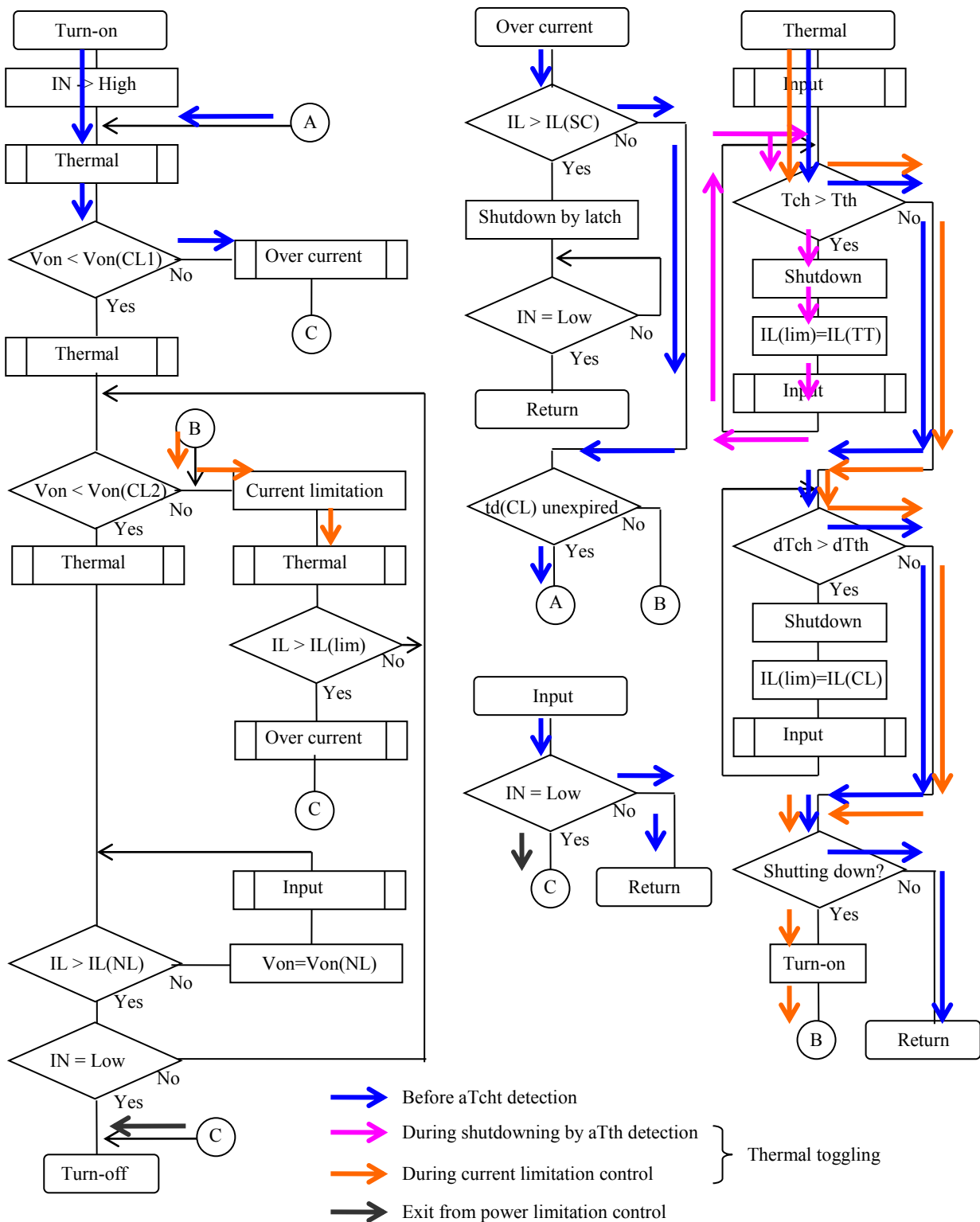

An over load condition which is include a short circuit condition during on-state

(a) $V_{on} > V_{on(CL)}$ with weak short condition

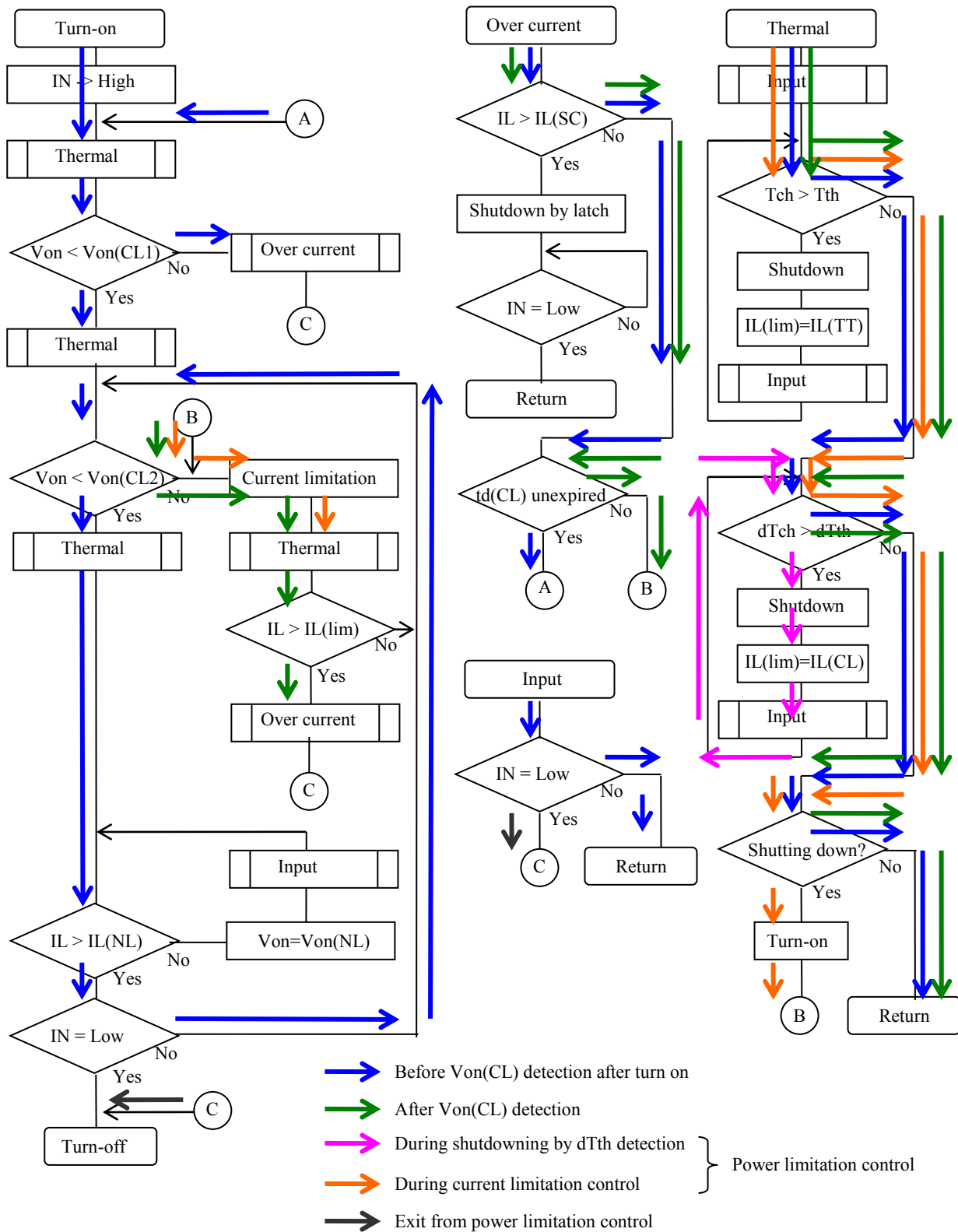

An over load condition including short circuit condition during on-state

(a) $V_{on} > V_{on(CL)}$ with dead condition

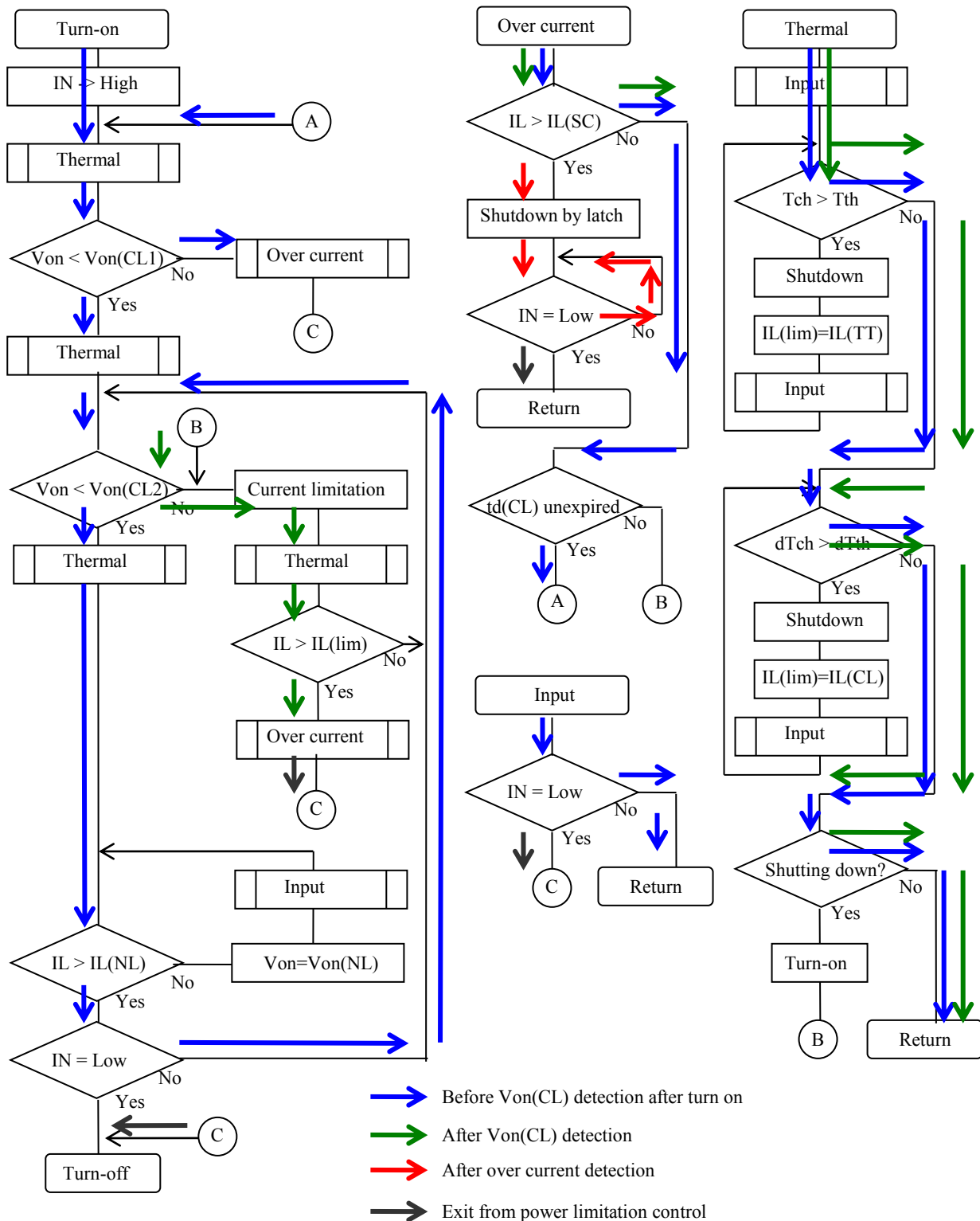

An over load condition including short circuit condition during on-state

(b) $\Delta T_{ch} > \Delta T_{th}$

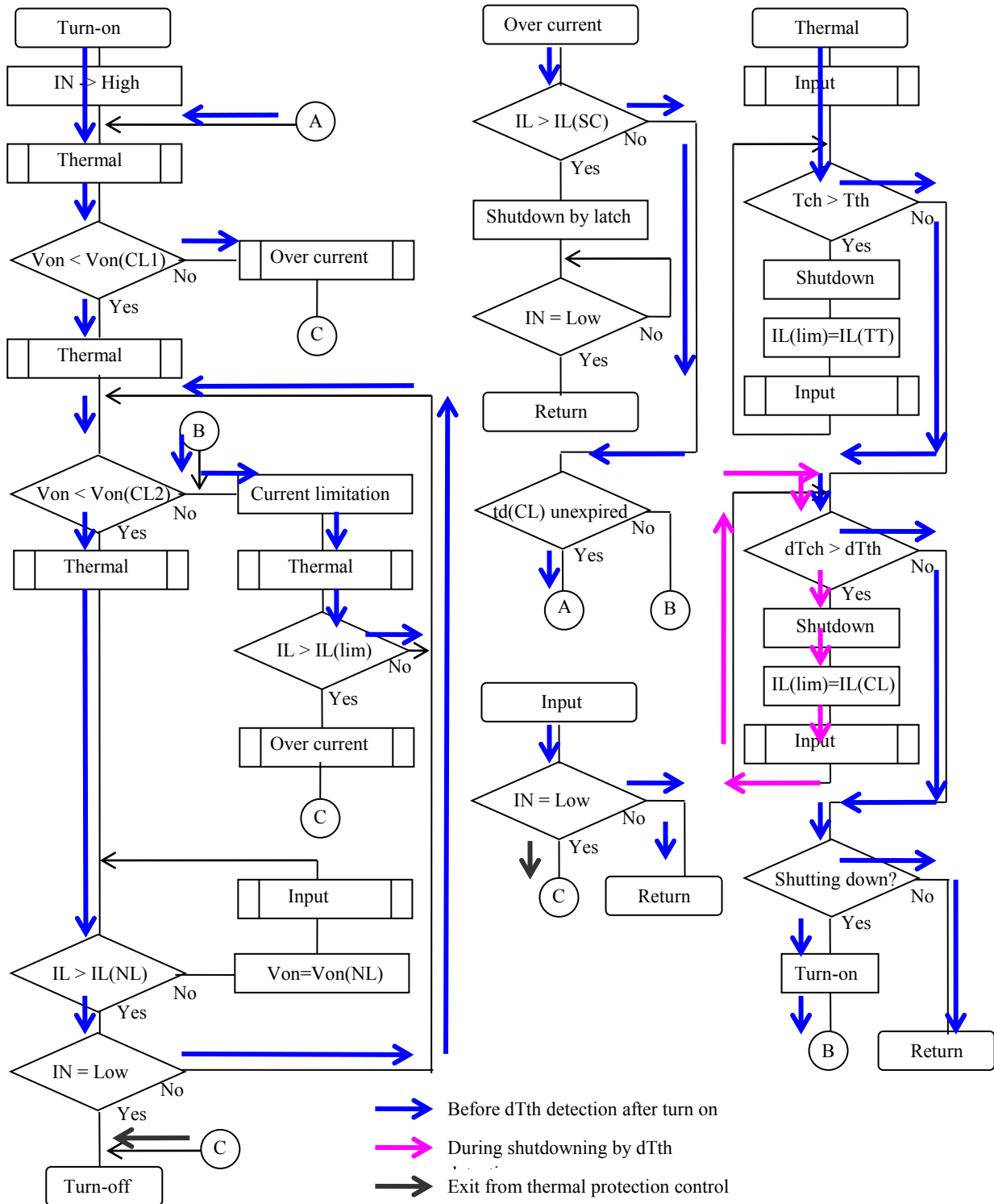

An over load condition including short circuit condition during on-state

(c) $T_{ch} > aT_{th}$

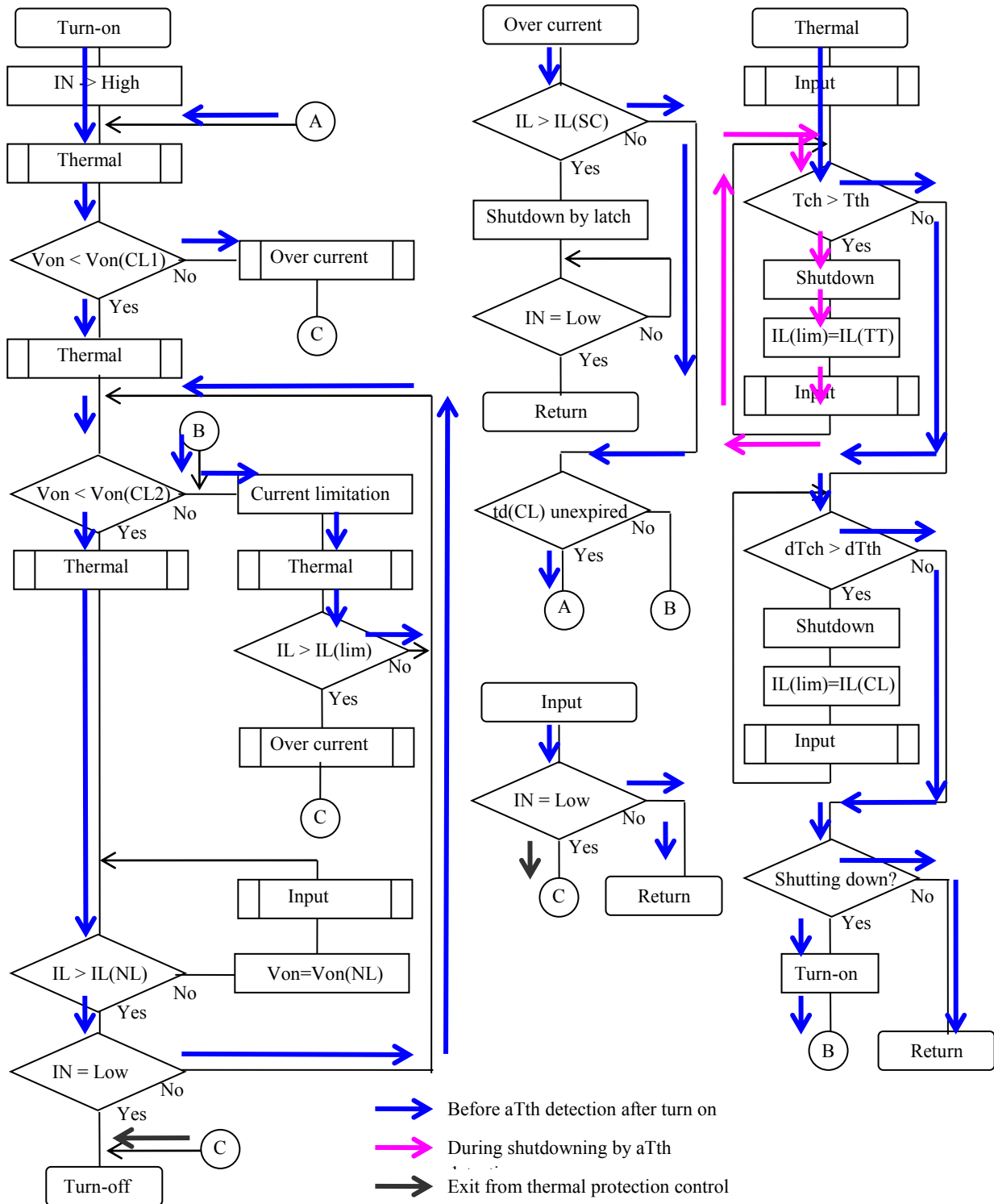

3.6.6 Device behavior at small load current conduction

The device has a function which controls Ron in order to improve KILIS accuracy at small load current conduction. Von (VCC-OUT) is proportionate to IL under normal conditions. Under $IL < IL(NL)$ condition, Ron is controlled to increase to be $Von = Von(NL) = 30mV(typ)$.

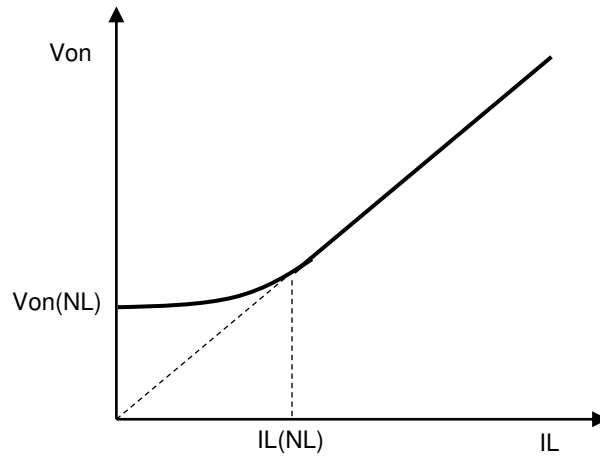

3.6.7 Diagnostic signal

Truth table

	SEN	Input	Output	Diagnostic output ²⁾
Normal Operation	H	H	VCC	IIS = IL/KILIS
		L	L ¹⁾	< 1μA (Iis,dis)
Shutdown by over current detection		H	L ¹⁾	Iis,fault ³⁾
		L	L ¹⁾	< 1μA (Iis,dis)
Power limitation		H	VOUT ⁶⁾	IIS = IL/KILIS in case of Von<Von(CL1) Iis,fault ⁴⁾ in case of Von>Von(CL1)
			L ¹⁾	Iis,fault ⁴⁾
		L	L ¹⁾	< 1μA (Iis,dis)
Thermal toggling		H	VOUT ⁶⁾	IIS = IL/KILIS in case of Von<Von(CL1) Iis,fault ⁵⁾ in case of Von>Von(CL1)
			L ¹⁾	Iis, fault ⁵⁾
		L	L ¹⁾	< 1μA (Iis,dis)
Short circuit to VCC	H	VCC	< 2μA (Iis,offset)	
	L	VOUT ⁷⁾	Iis,fault in case of VOUT>VOUT(OL)	
Open Load	H	VCC	< 2μA (Iis,offset)	
	L	VOUT ⁷⁾	Iis,fault in case of VOUT>VOUT(OL)	
X ⁸⁾	L	X ⁸⁾	X ⁸⁾	< 1μA (Iis,dis)

- 1) In case of OUT terminal is connected to GND via load.
- 2) In case of IS terminal is connected to GND via resistor.
- 3) IS terminal keeps Iis,fault as long as input signal activate after the over current detection.
- 4) IS terminal keeps Iis,fault during power limitation if Von>Von(CL1).
- 5) IS terminal keeps Iis,fault during thermal toggling if Von>Von(CL1)..
- 6) VOUT depends on the short circuit condition
- 7) VOUT depends on the ratio of VCC-OUT-GND resistive component.
- 8) Don't care

Current sense output

The device output analog feedback current proportional to output current from IS pin. In the case of much higher current than nominal load current, current sense output is saturated. In the case of much lower current than nominal load current, current sense output is above 5μA if output current is above IL(CSE) max, current sense output is below 2μA, IIS,offset max, if output current is below IL(CSE) min.

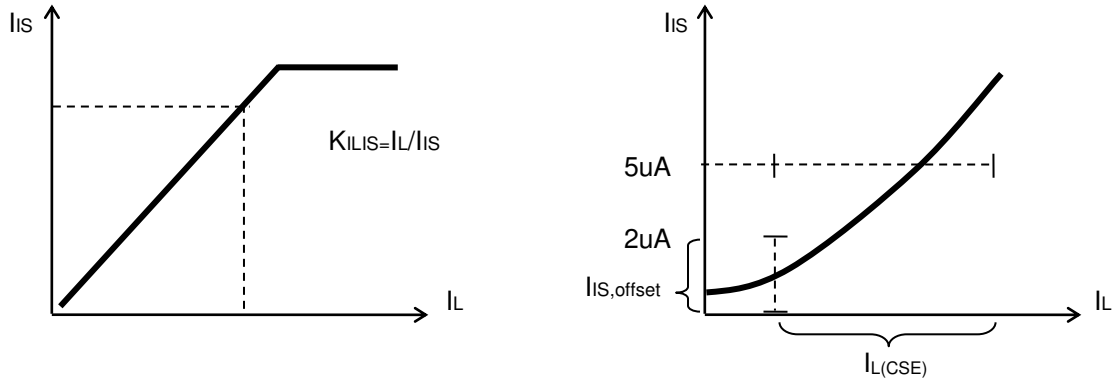

Sense current under fault condition

The device output IIS,fault, constant current, from IS pin under fault condition such as after over current detection, during power limitation and during thermal toggling. IIS,fault is specified with RIS=1kΩ condition. IIS,fault is attenuated depends on VCC-VIS voltage. Operation point as IIS,fault output is also depends on RIS condition. For example, In the case of RIS=1kΩ, IIS,fault could be 3.5mA to 9mA, VCC-VIS could be 4.5V to 10V, VIS could be 9V to 3.5V if VCC=13.5V. In the case of RIS is higher than 1kΩ, Operation point as IIS,fault is lower than specified value but VIS should be higher than RIS=1kΩ condition.

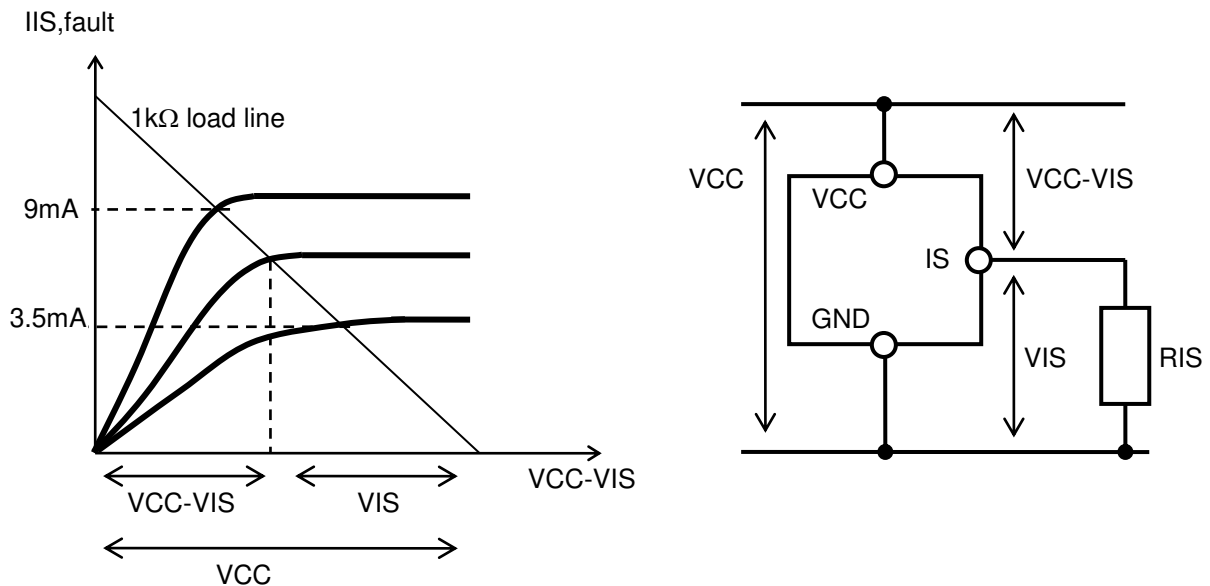

Sense current settling time

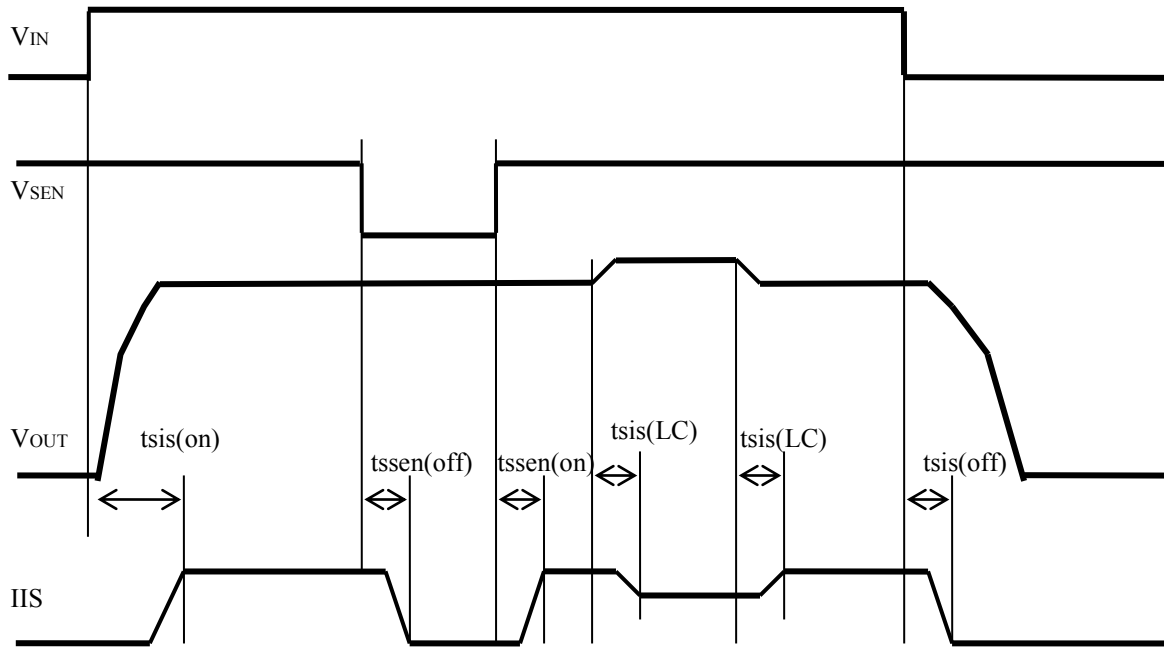

Fault signal delay time at over current detection

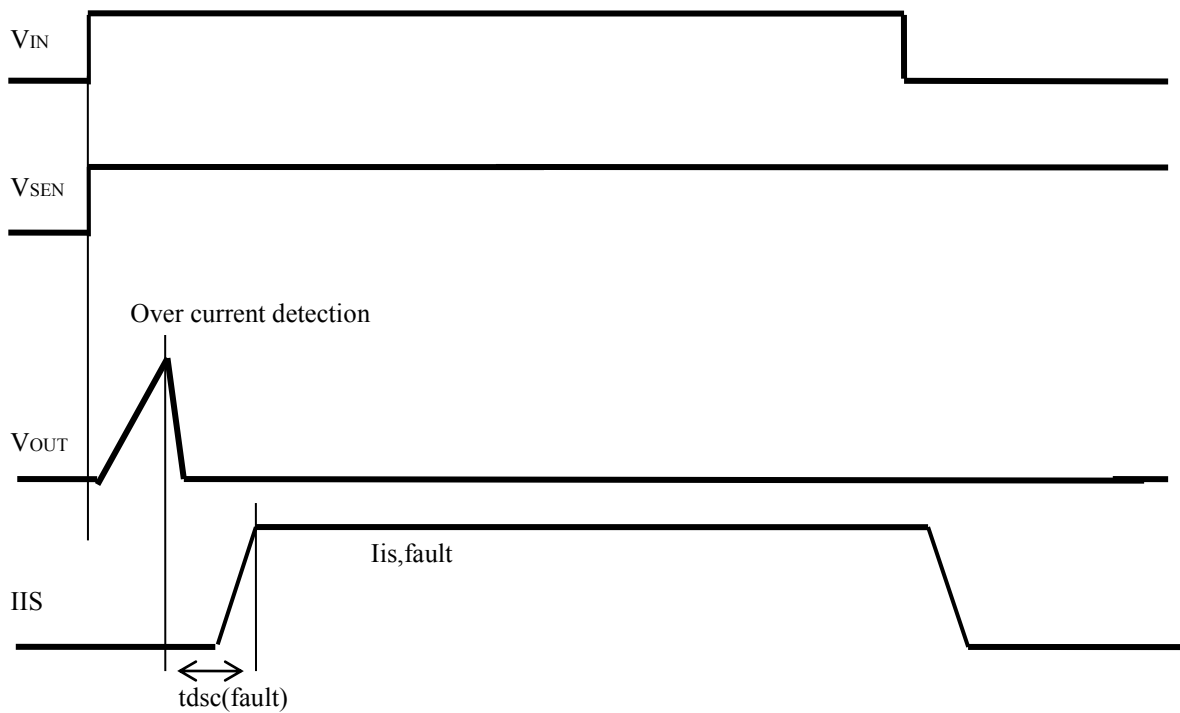

Fault signal delay time at power limitation

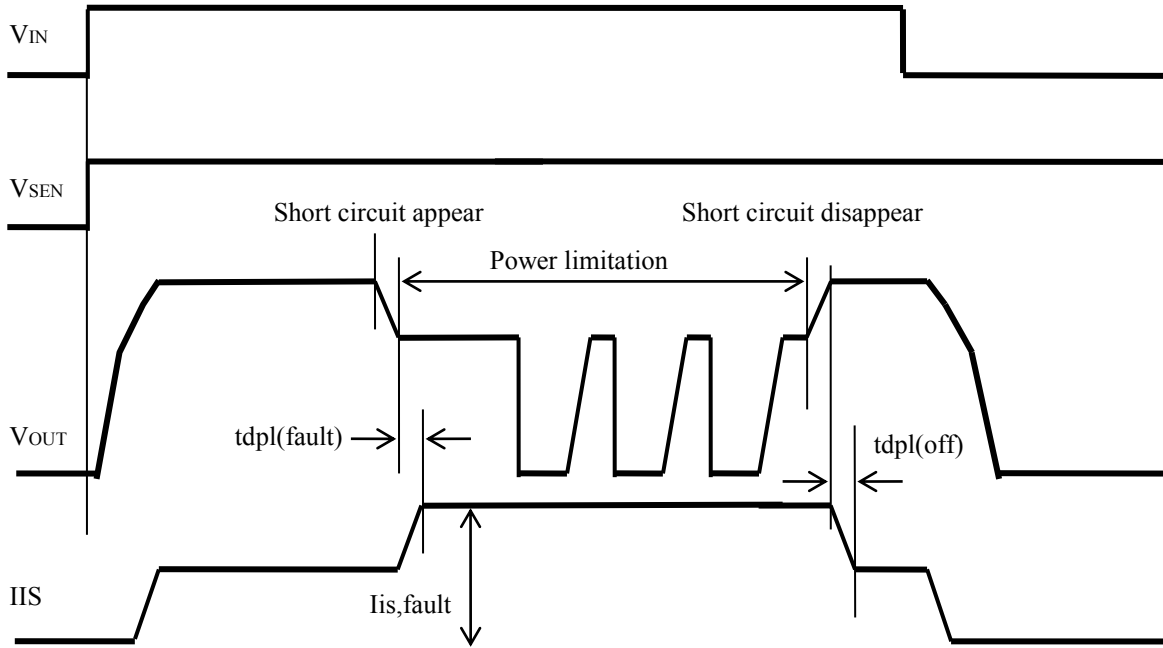

Fault signal delay time at Thermal toggling

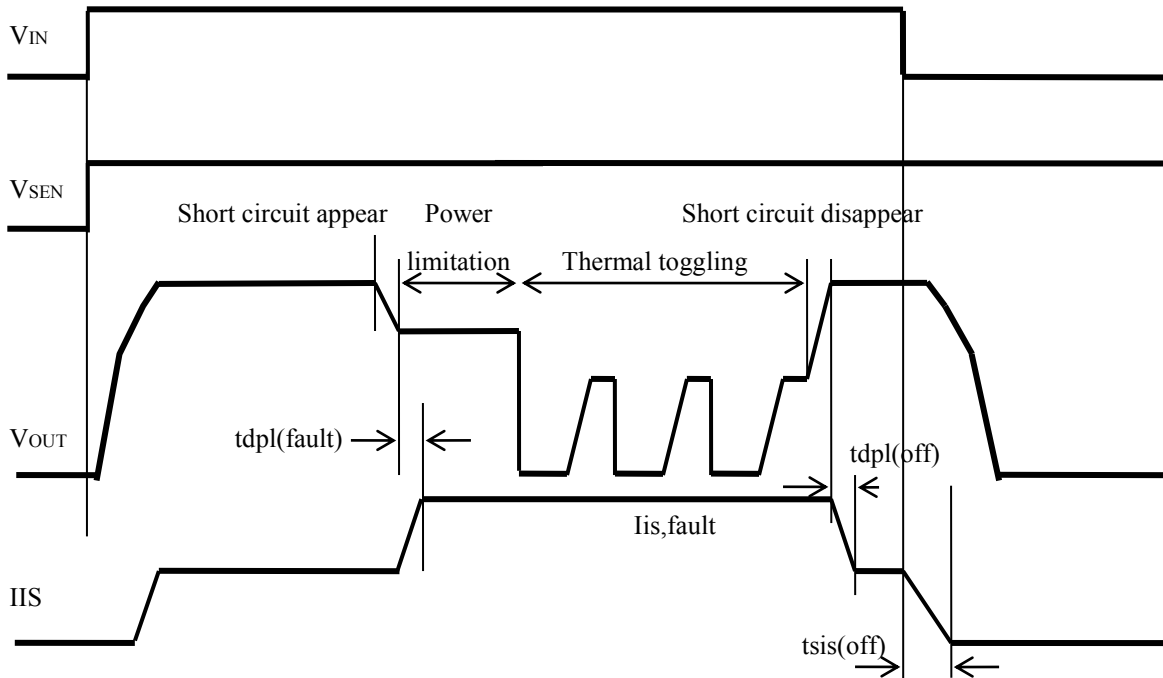

Fault signal delay time at open load detection

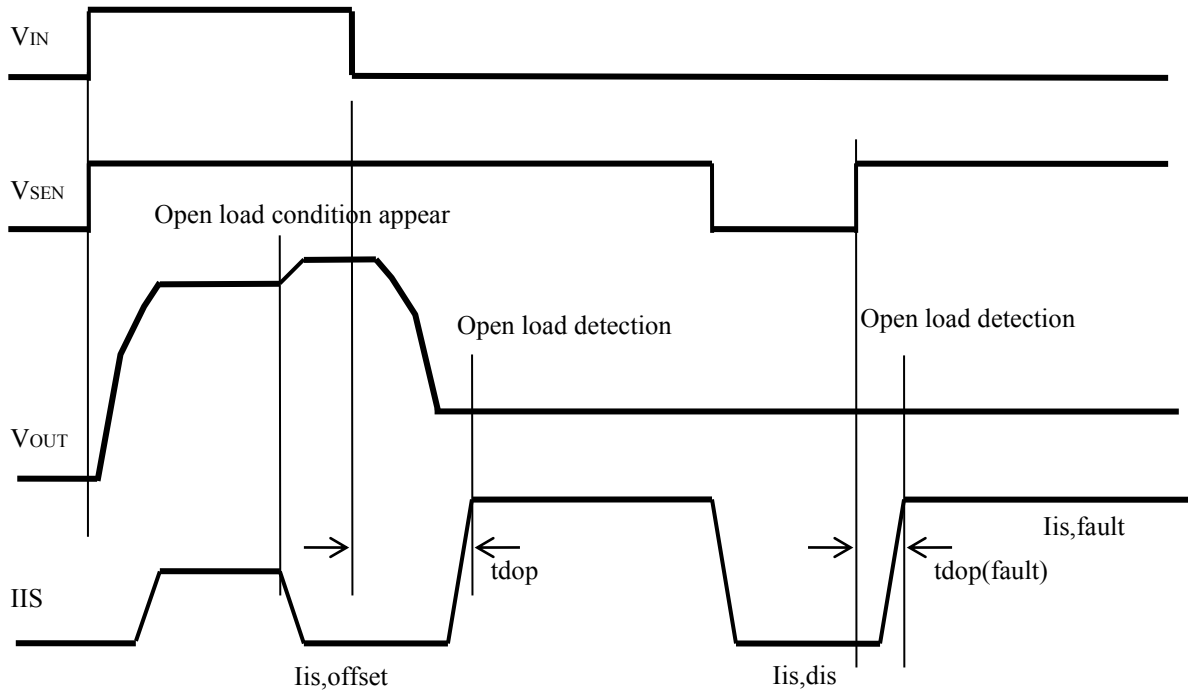

3.6.8 Nominal load

Product	Nominal load
NHS010A	2.0Ω

3.6.9 Driving Capability

Driving Capability is specified as load impedance. Over current detection characteristics is designed above Driving Capability characteristics. If estimated load impedance which comes from peak inrush current is lower than Driving Capability characteristics, this means, the device does not detect inrush current as over current and does not shutdown the output. Depend on the conditions, Power Limitation function may work during inrush current. If estimated load impedance which comes from peak inrush current is lower than Driving Capability characteristics, Power limitation disappear within 30ms. This parameter does not mean that the device can drive the resistive load up to Driving Capability characteristics.

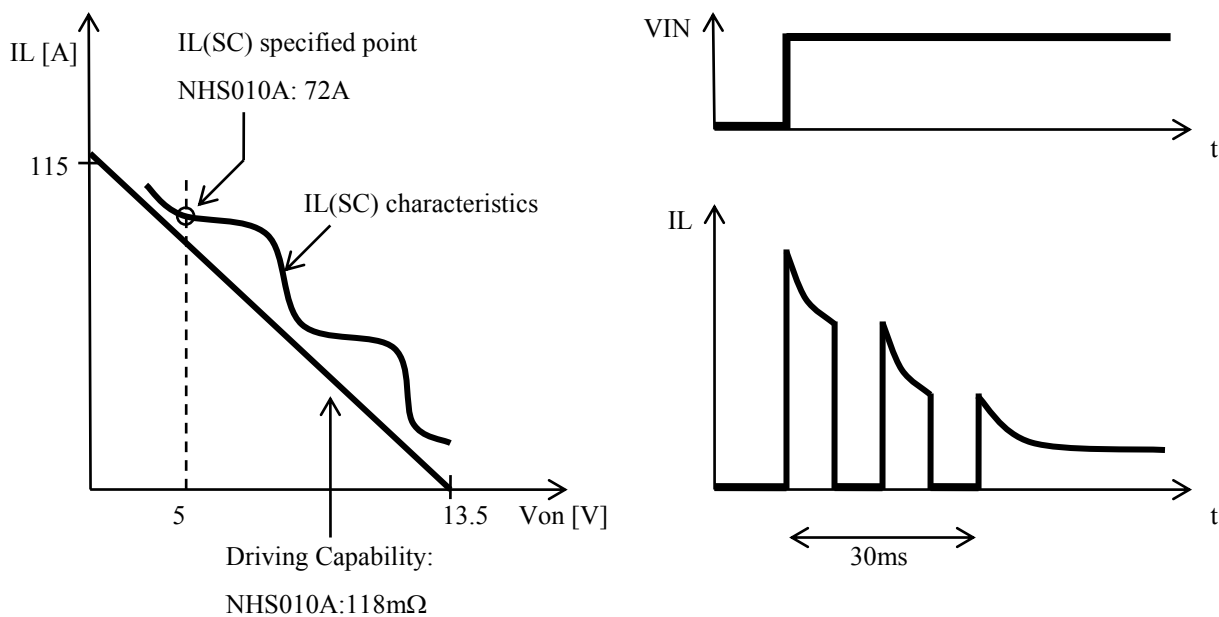

3.6.10 Cross current protection in case of H-bridge high side usage

In case of using High side driver in H-bridge circuit, High side driver protects High side driver itself and also low side driver from high power dissipation by cross current when low side driver switching on.

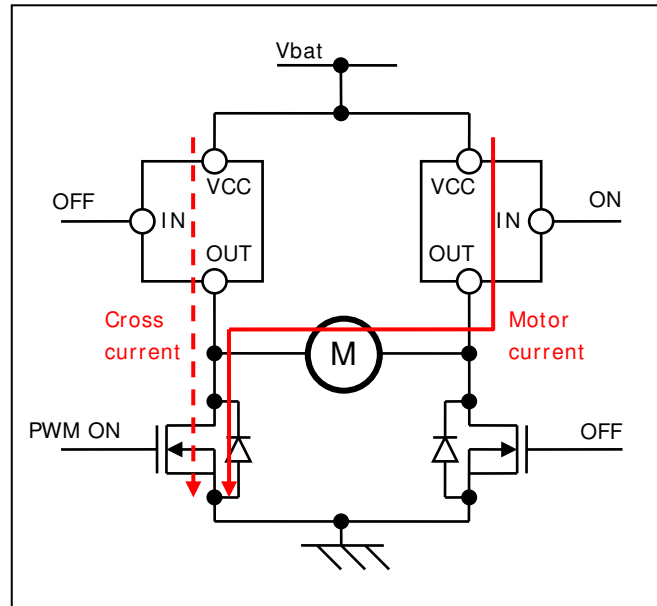

3.6.11 Measurement condition

Switching waveform of OUT terminal

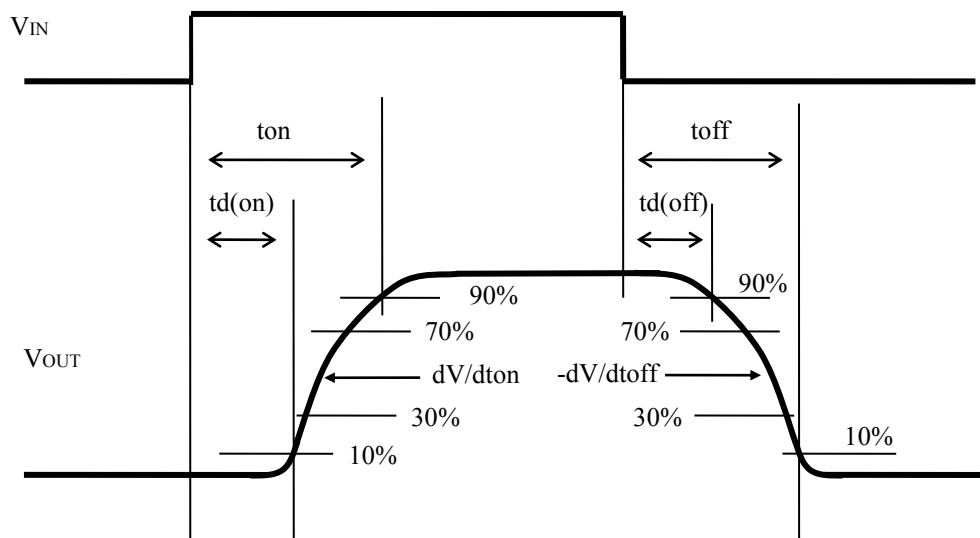

3.7 Package drawing

JEITA Package Code	Renesas Code	Previous Code	Mass(TYP.)[g]
-	PRSS0008ZA-A	P7J5-85-314	0.33

Unit : mm

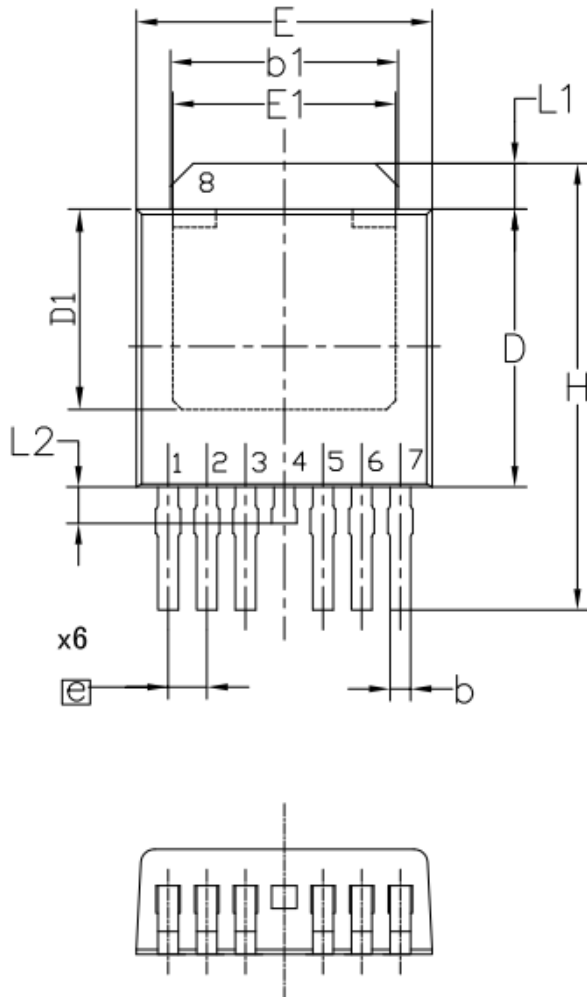

ITEM	DIMENSIONS
D	6.10±0.20
D1	4.4TYP(4.0MIN)
E	6.50±0.20
E1	4.9TYP(4.8MIN)
H	9.8TYP(10.3MAX)
A	2.30±0.10
A1	0.125MAX
b	0.45±0.10
b1	5.0
c	0.50±0.10
c1	0.50±0.10
c2	0.508
e	0.85
L	1.52±0.12
L1	1.0
L2	0.80

NOTE
 1, No Plating area

3.8 Taping information

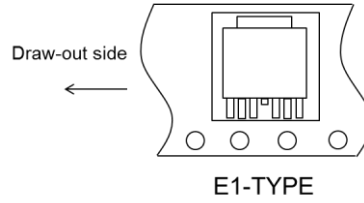

3.9 Marking information

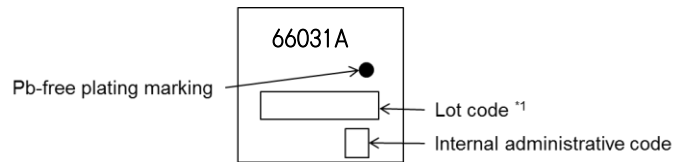

Note: *1. Composition of the lot code

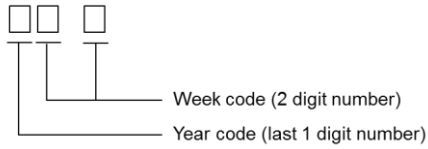

4. Typical characteristics

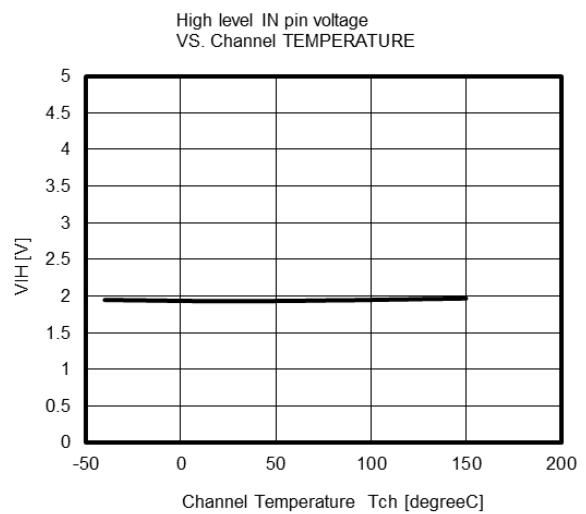
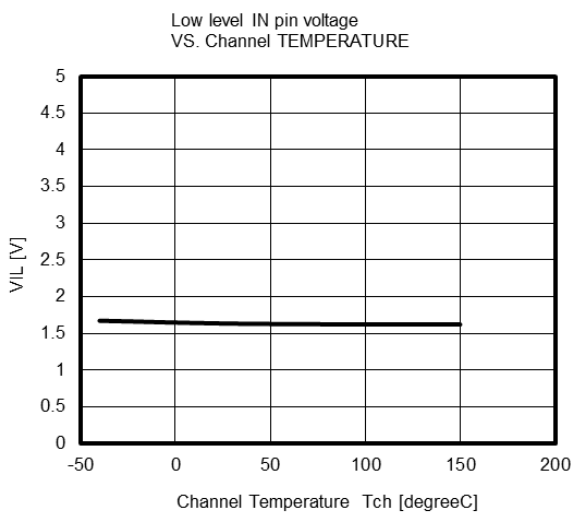
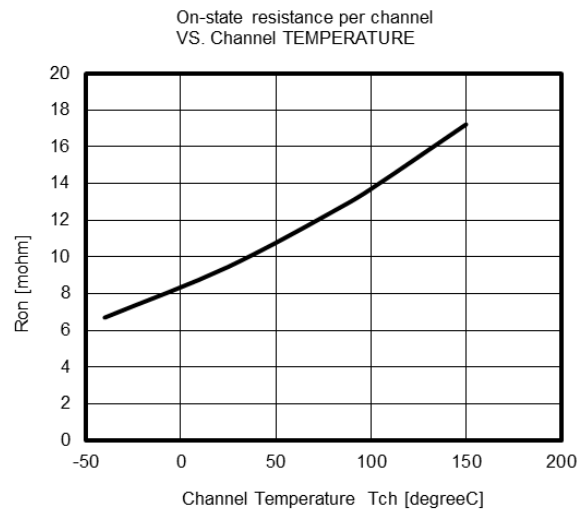
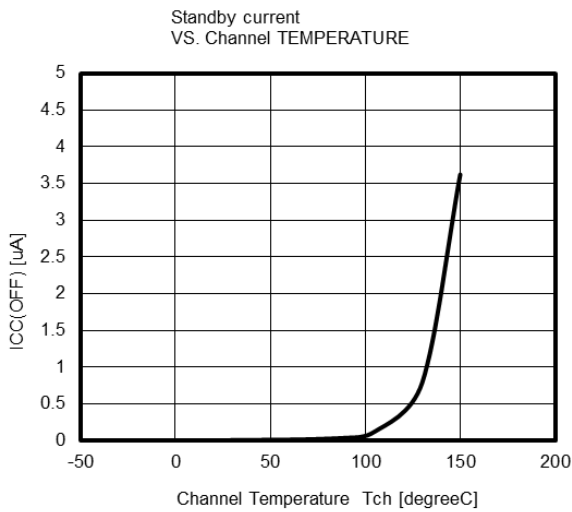
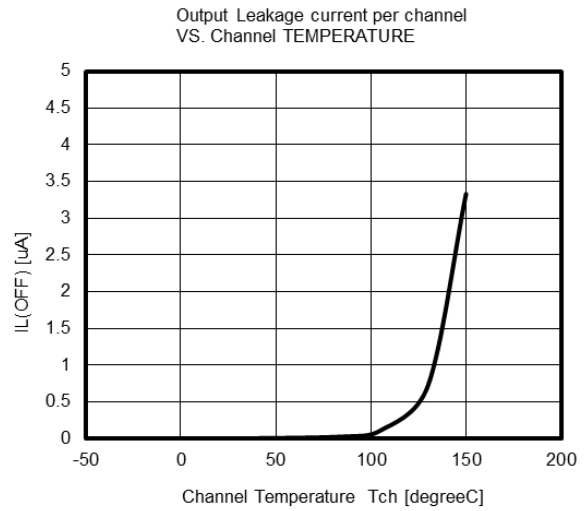
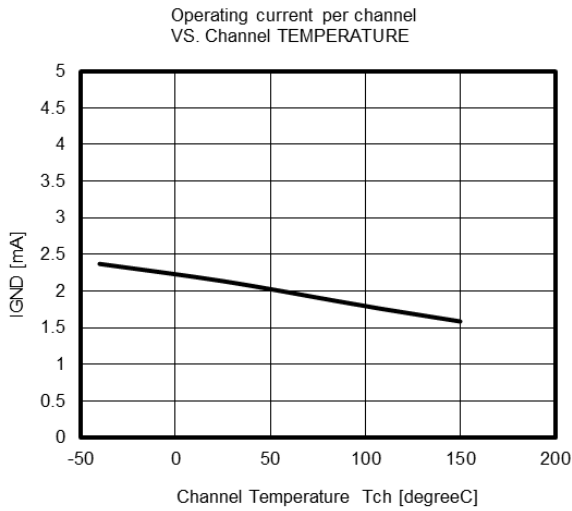

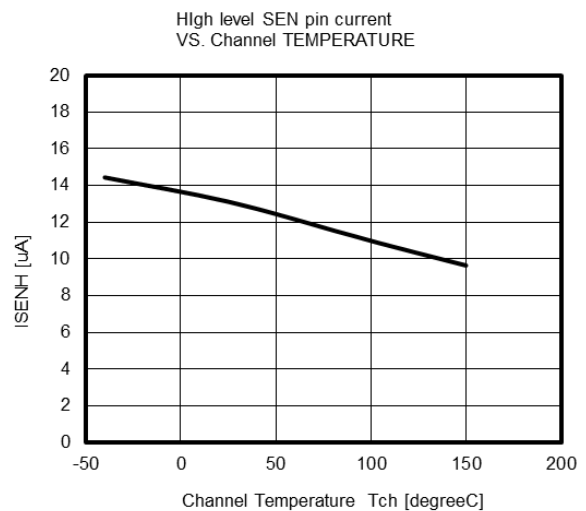
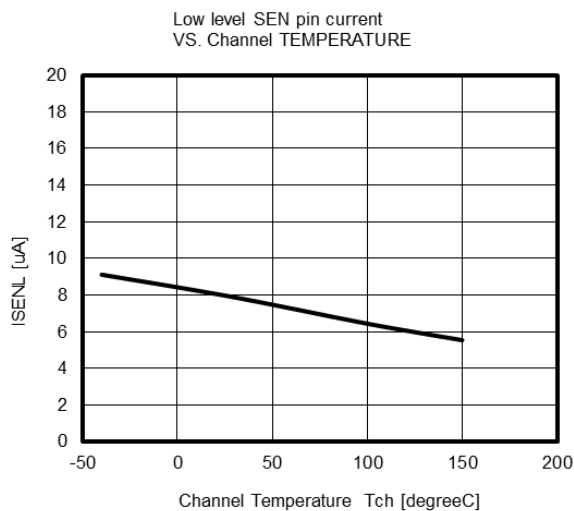
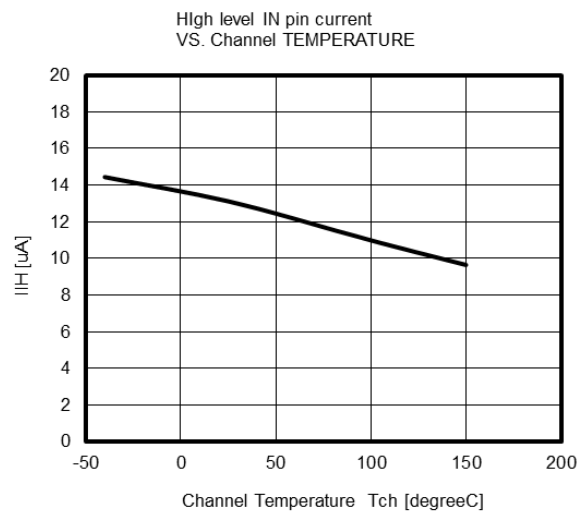
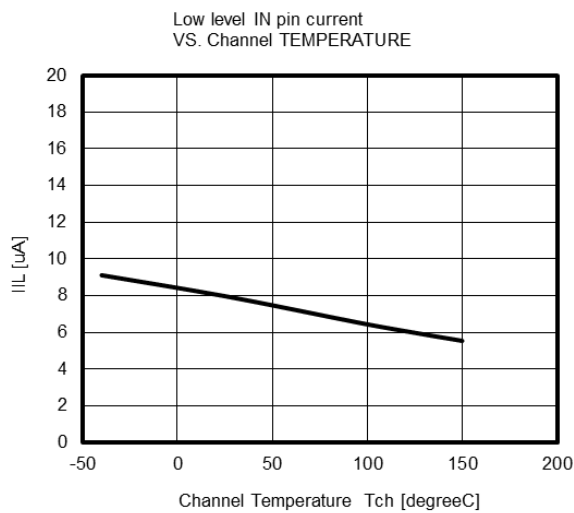
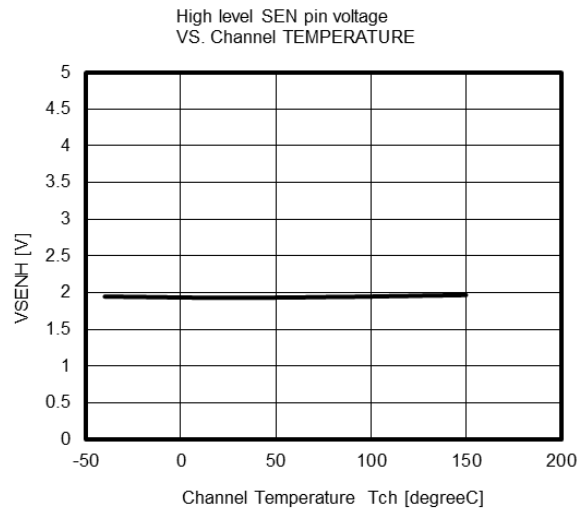
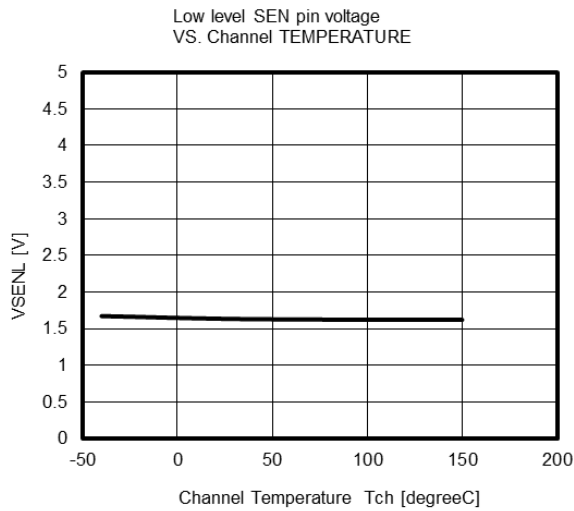

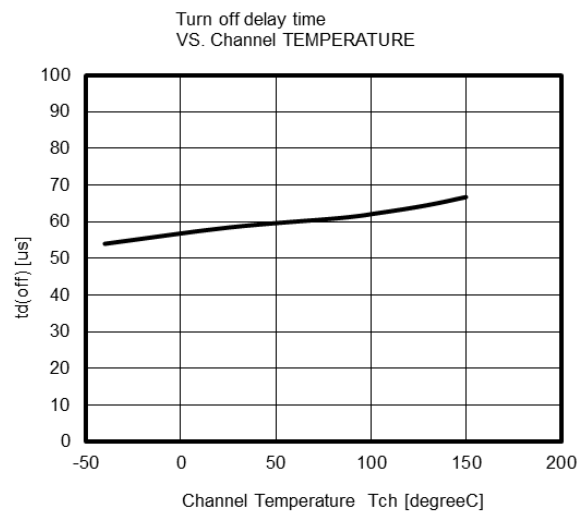
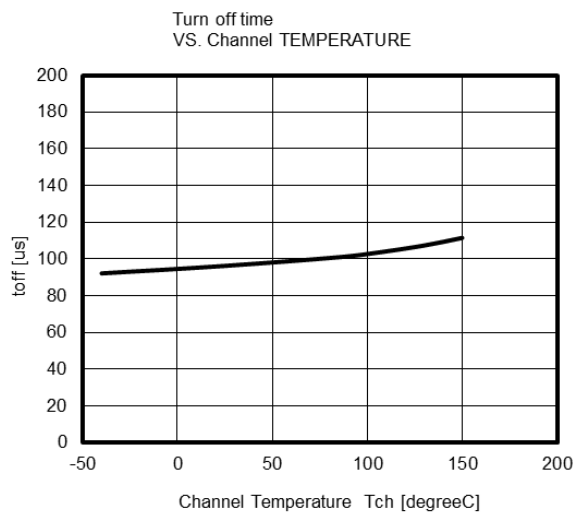
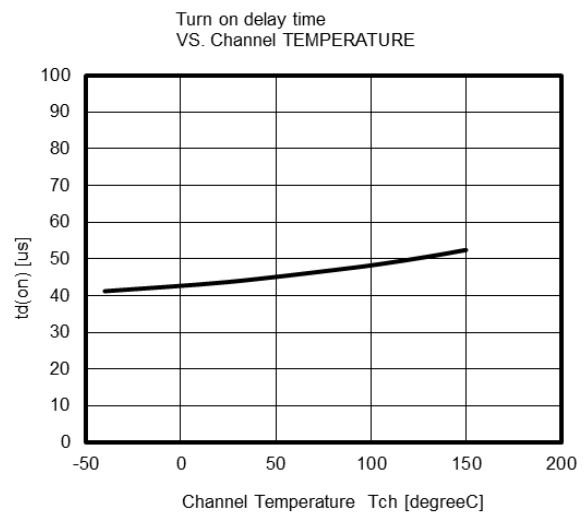
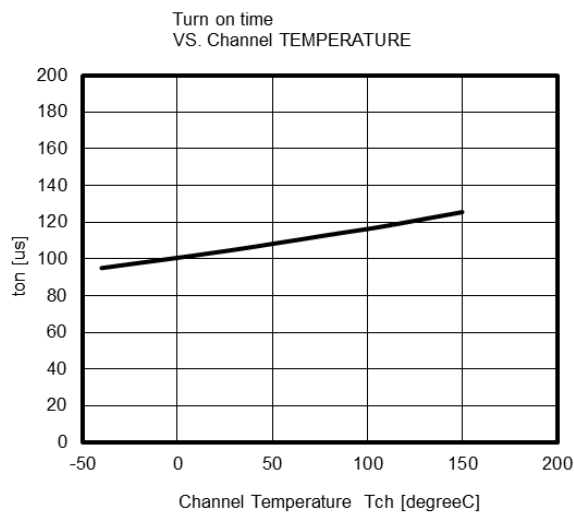
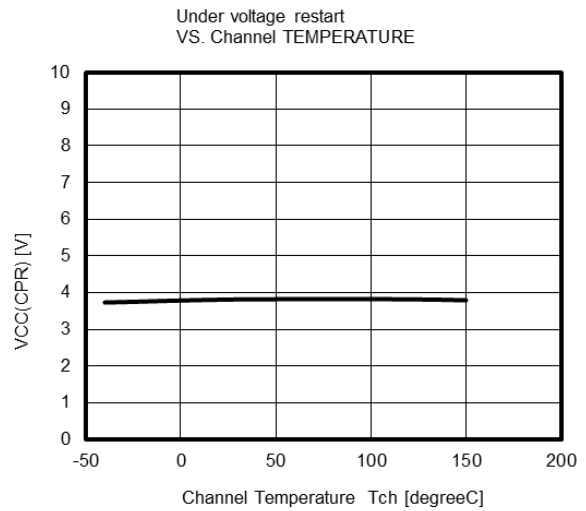
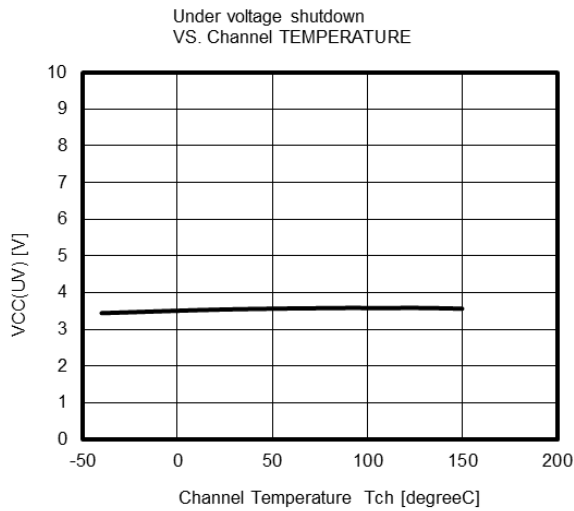

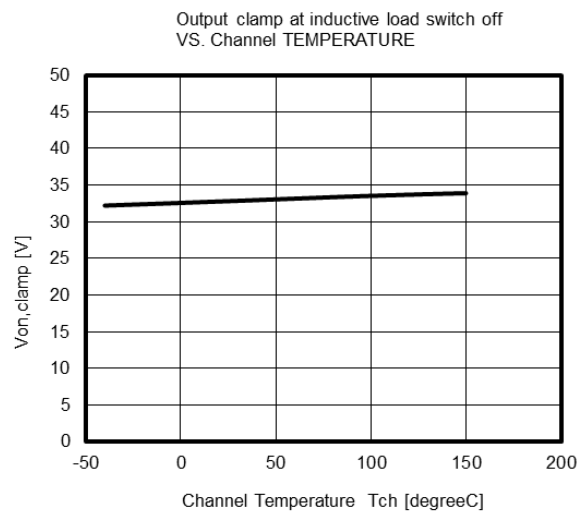
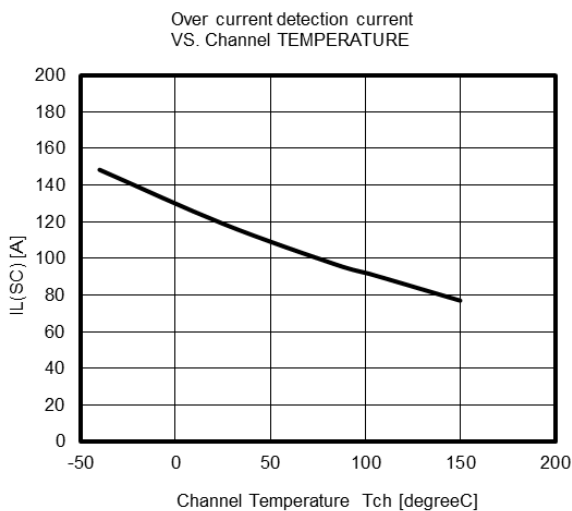
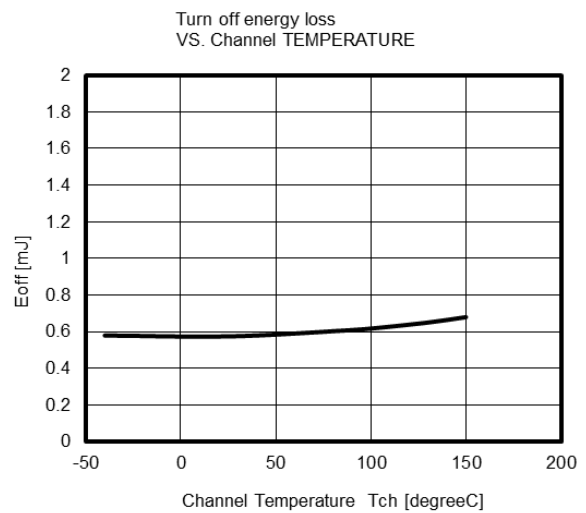
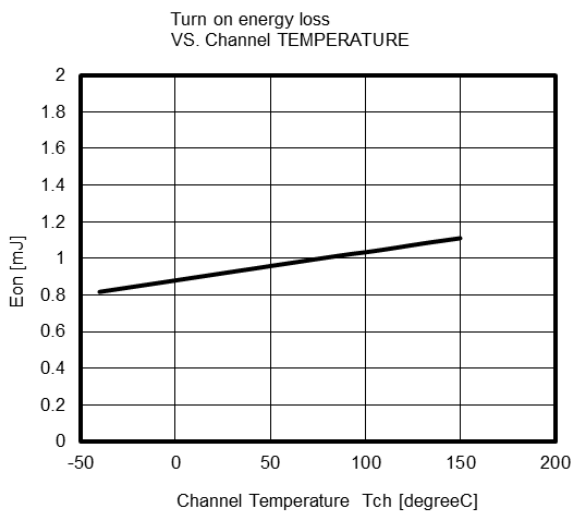
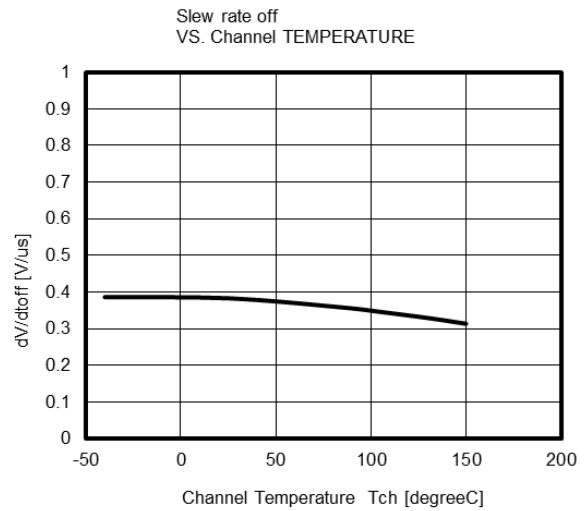
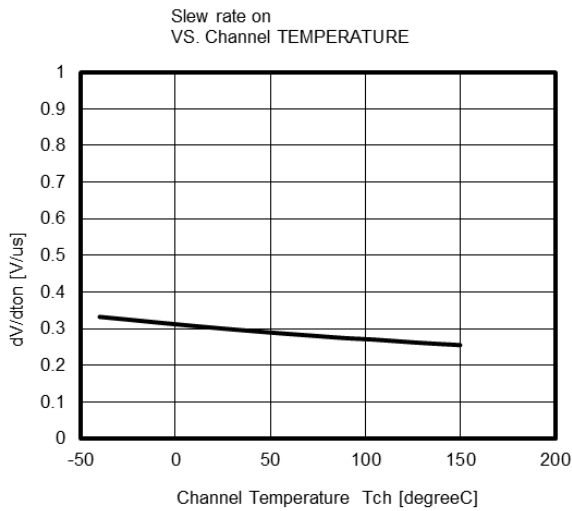

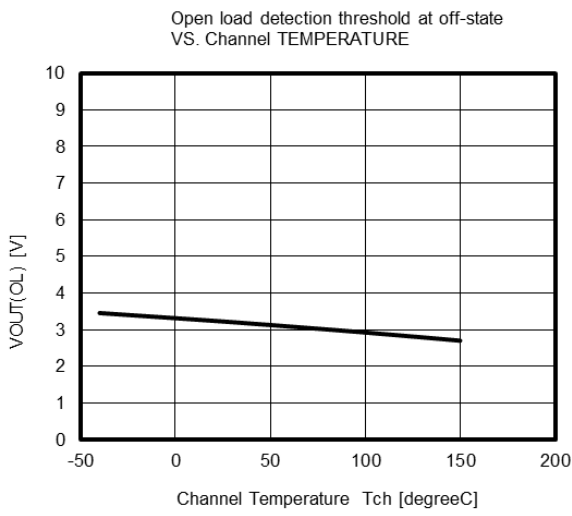
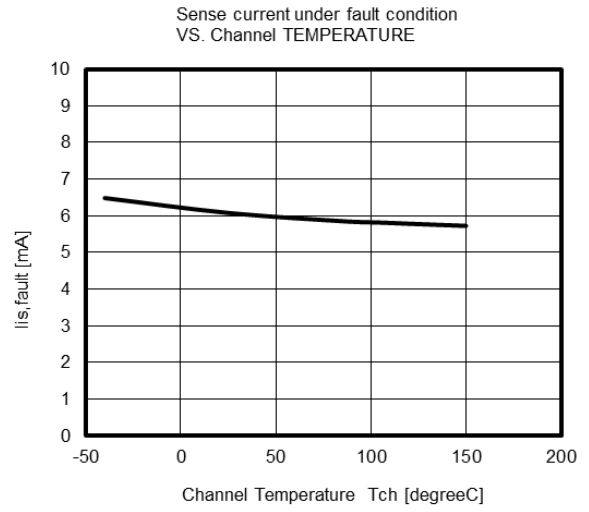
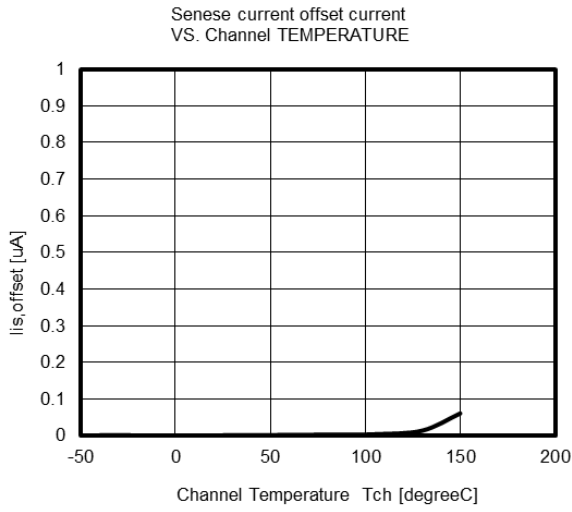

5. Thermal characteristics

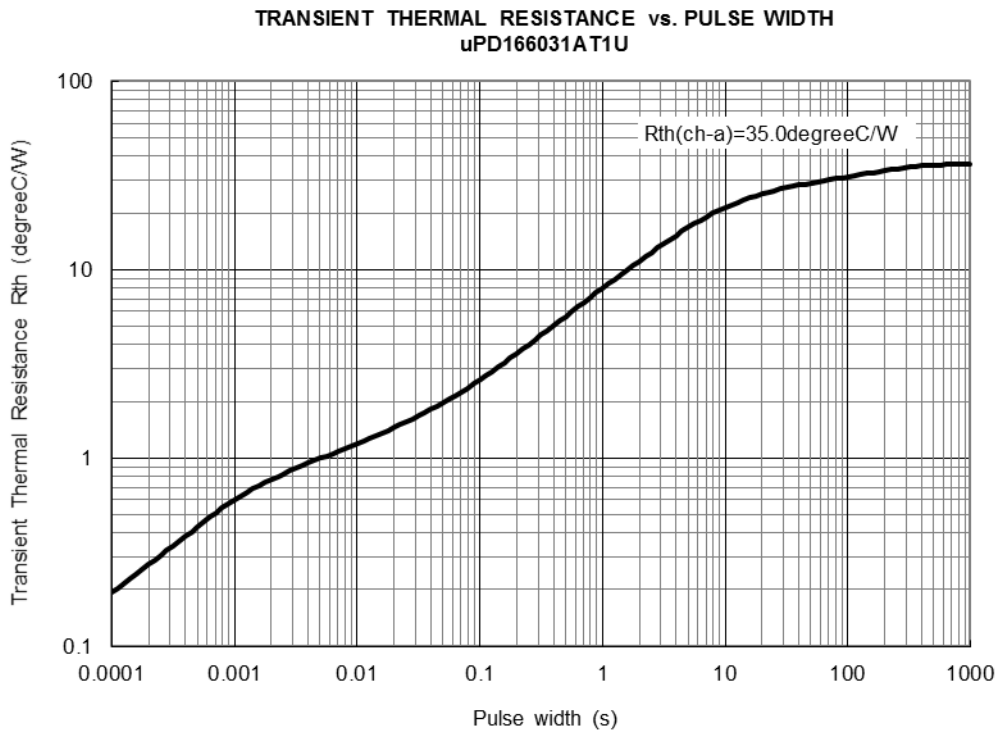

6. Application example in principle

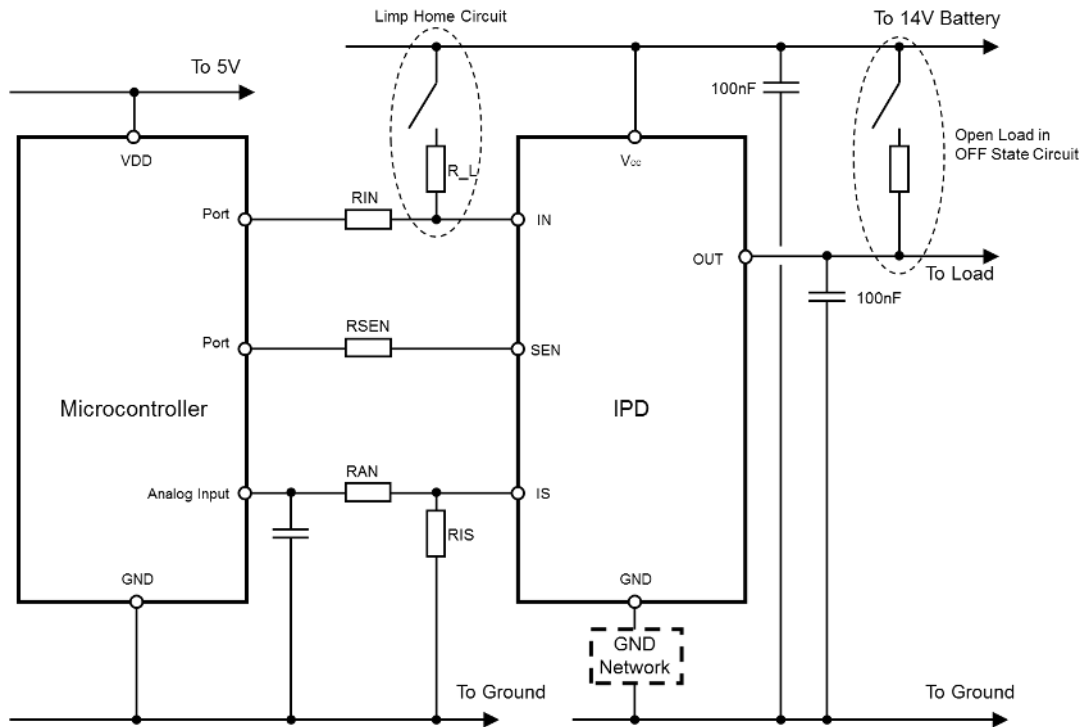

RIN, RSEN, RAN values are in range of 2k to 50kΩ depending microcontroller while R_L value is typically 4kΩ. If necessary to raise HBM tolerated dose, adding resistor between OUT terminal and Ground is effective. Resistor's value is typically 100kΩ

GND Network recommendation

In case of V_{load}dump < 35V

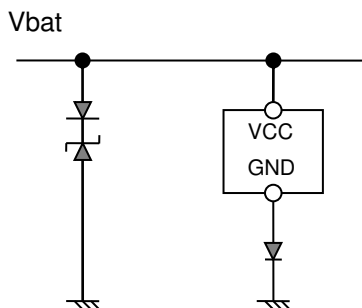

External diode is recommended in order to prevent reverse current toward control logic part at reverse battery condition.

In case of 35V < V_{load}dump < 42V

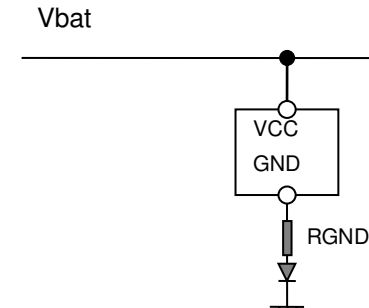

External diode and resistor are recommended in order to prevent reverse current toward control logic part at reverse battery condition and limit the current through ZD_{AZ} at load dump condition. 100Ω is recommended as RGND.

Note: If other component is installed to prevent reverse current at reverse battery condition, diode is not required in GND Network.

Note: Approx. 1kΩ additional resistor in parallel with the diode is recommended if Vf value of the diode is high.

Revision History	μPD166031AT1U Datasheet
-------------------------	--------------------------------

Rev.	Date	Description	
		Page	Summary
1.00	Oct. 30, 2015	1-39	1st issue

All trademarks and registered trademarks are the property of their respective owners.

Notice

1. Descriptions of circuits, software and other related information in this document are provided only to illustrate the operation of semiconductor products and application examples. You are fully responsible for the incorporation of these circuits, software, and information in the design of your equipment. Renesas Electronics assumes no responsibility for any losses incurred by you or third parties arising from the use of these circuits, software, or information.
2. Renesas Electronics has used reasonable care in preparing the information included in this document, but Renesas Electronics does not warrant that such information is error free. Renesas Electronics assumes no liability whatsoever for any damages incurred by you resulting from errors in or omissions from the information included herein.
3. Renesas Electronics does not assume any liability for infringement of patents, copyrights, or other intellectual property rights of third parties by or arising from the use of Renesas Electronics products or technical information described in this document. No license, express, implied or otherwise, is granted hereby under any patents, copyrights or other intellectual property rights of Renesas Electronics or others.
4. You should not alter, modify, copy, or otherwise misappropriate any Renesas Electronics product, whether in whole or in part. Renesas Electronics assumes no responsibility for any losses incurred by you or third parties arising from such alteration, modification, copy or otherwise misappropriation of Renesas Electronics product.
5. Renesas Electronics products are classified according to the following two quality grades: "Standard" and "High Quality". The recommended applications for each Renesas Electronics product depends on the product's quality grade, as indicated below.
"Standard": Computers; office equipment; communications equipment; test and measurement equipment; audio and visual equipment; home electronic appliances; machine tools; personal electronic equipment; and industrial robots etc.
"High Quality": Transportation equipment (automobiles, trains, ships, etc.); traffic control systems; anti-disaster systems; anti-crime systems; and safety equipment etc.
Renesas Electronics products are neither intended nor authorized for use in products or systems that may pose a direct threat to human life or bodily injury (artificial life support devices or systems, surgical implantations etc.), or may cause serious property damages (nuclear reactor control systems, military equipment etc.). You must check the quality grade of each Renesas Electronics product before using it in a particular application. You may not use any Renesas Electronics product for any application for which it is not intended. Renesas Electronics shall not be in any way liable for any damages or losses incurred by you or third parties arising from the use of any Renesas Electronics product for which the product is not intended by Renesas Electronics.
6. You should use the Renesas Electronics products described in this document within the range specified by Renesas Electronics, especially with respect to the maximum rating, operating supply voltage range, movement power voltage range, heat radiation characteristics, installation and other product characteristics. Renesas Electronics shall have no liability for malfunctions or damages arising out of the use of Renesas Electronics products beyond such specified ranges.
7. Although Renesas Electronics endeavors to improve the quality and reliability of its products, semiconductor products have specific characteristics such as the occurrence of failure at a certain rate and malfunctions under certain use conditions. Further, Renesas Electronics products are not subject to radiation resistance design. Please be sure to implement safety measures to guard them against the possibility of physical injury, and injury or damage caused by fire in the event of the failure of a Renesas Electronics product, such as safety design for hardware and software including but not limited to redundancy, fire control and malfunction prevention, appropriate treatment for aging degradation or any other appropriate measures. Because the evaluation of microcomputer software alone is very difficult, please evaluate the safety of the final products or systems manufactured by you.
8. Please contact a Renesas Electronics sales office for details as to environmental matters such as the environmental compatibility of each Renesas Electronics product. Please use Renesas Electronics products in compliance with all applicable laws and regulations that regulate the inclusion or use of controlled substances, including without limitation, the EU RoHS Directive. Renesas Electronics assumes no liability for damages or losses occurring as a result of your noncompliance with applicable laws and regulations.
9. Renesas Electronics products and technology may not be used for or incorporated into any products or systems whose manufacture, use, or sale is prohibited under any applicable domestic or foreign laws or regulations. You should not use Renesas Electronics products or technology described in this document for any purpose relating to military applications or use by the military, including but not limited to the development of weapons of mass destruction. When exporting the Renesas Electronics products or technology described in this document, you should comply with the applicable export control laws and regulations and follow the procedures required by such laws and regulations.
10. It is the responsibility of the buyer or distributor of Renesas Electronics products, who distributes, disposes of, or otherwise places the product with a third party, to notify such third party in advance of the contents and conditions set forth in this document, Renesas Electronics assumes no responsibility for any losses incurred by you or third parties as a result of unauthorized use of Renesas Electronics products.
11. This document may not be reproduced or duplicated in any form, in whole or in part, without prior written consent of Renesas Electronics.
12. Please contact a Renesas Electronics sales office if you have any questions regarding the information contained in this document or Renesas Electronics products, or if you have any other inquiries.

(Note 1) "Renesas Electronics" as used in this document means Renesas Electronics Corporation and also includes its majority-owned subsidiaries.

(Note 2) "Renesas Electronics product(s)" means any product developed or manufactured by or for Renesas Electronics.



SALES OFFICES

Renesas Electronics Corporation

<http://www.renesas.com>

Refer to "<http://www.renesas.com/>" for the latest and detailed information.

Renesas Electronics America Inc.
2801 Scott Boulevard Santa Clara, CA 95050-2549, U.S.A.
Tel: +1-408-588-6000, Fax: +1-408-588-6130

Renesas Electronics Canada Limited
9251 Yonge Street, Suite 8309 Richmond Hill, Ontario Canada L4C 9T3
Tel: +1-905-237-2004

Renesas Electronics Europe Limited
Dukes Meadow, Millboard Road, Bourne End, Buckinghamshire, SL8 5FH, U.K
Tel: +44-1628-585-100, Fax: +44-1628-585-900

Renesas Electronics Europe GmbH
Arcadiastrasse 10, 40472 Düsseldorf, Germany
Tel: +49-211-6503-0, Fax: +49-211-6503-1327

Renesas Electronics (China) Co., Ltd.
Room 1709, Quantum Plaza, No.27 ZhiChunLu Haidian District, Beijing 100191, P.R.China
Tel: +86-10-8235-1155, Fax: +86-10-8235-7679

Renesas Electronics (Shanghai) Co., Ltd.
Unit 301, Tower A, Central Towers, 555 Langao Road, Putuo District, Shanghai, P. R. China 200333
Tel: +86-21-2226-0888, Fax: +86-21-2226-0899

Renesas Electronics Hong Kong Limited
Unit 1601-1611, 16/F., Tower 2, Grand Century Place, 193 Prince Edward Road West, Mongkok, Kowloon, Hong Kong
Tel: +852-2265-6688, Fax: +852-2886-9022

Renesas Electronics Taiwan Co., Ltd.
13F, No. 363, Fu Shing North Road, Taipei 10543, Taiwan
Tel: +886-2-8175-9600, Fax: +886-2-8175-9670

Renesas Electronics Singapore Pte. Ltd.
80 Bendemeer Road, Unit #06-02 Hyflux Innovation Centre, Singapore 339949
Tel: +65-6213-0200, Fax: +65-6213-0300

Renesas Electronics Malaysia Sdn.Bhd.
Unit 1207, Block B, Menara Amcorp, Amcorp Trade Centre, No. 18, Jln Persiaran Barat, 46050 Petaling Jaya, Selangor Darul Ehsan, Malaysia
Tel: +60-3-7955-9390, Fax: +60-3-7955-9510

Renesas Electronics India Pvt. Ltd.
No.777C, 100 Feet Road, HAL II Stage, Indiranagar, Bangalore, India
Tel: +91-80-67208700, Fax: +91-80-67208777

Renesas Electronics Korea Co., Ltd.
12F., 234 Teheran-ro, Gangnam-Gu, Seoul, 135-080, Korea
Tel: +82-2-558-3737, Fax: +82-2-558-5141