



8150 MHz Cavity Bandpass Filter

Part Number: AB8150B1240



ANATECH ELECTRONICS INC
RF & Microwave Filters & Products

Electrical specifications

Center Frequency: 8150MHz
Bandwidth: 500MHz
Frequency Range: 7900~8400MHz
Insertion Loss: =/ <1.5 dB
Return Loss: =/ >14 dB
Rejection: =/ >70 dB@7250MHz
Rejection 2: =/ >70 dB@9000MHz
Impedance: 50 Ohms In/Out
Power: 2 W

Mechanical

Mounting Method: Threaded Mounting
Connector Type: SMA (F)
Dimensions: 3.27" x 1.25" x 0.71" in
Surface Finish: Black

Environmental

Operating Temperature: -45°C to +85°C
Storage Temperature: -55°C to +100°C

Outline Drawing:

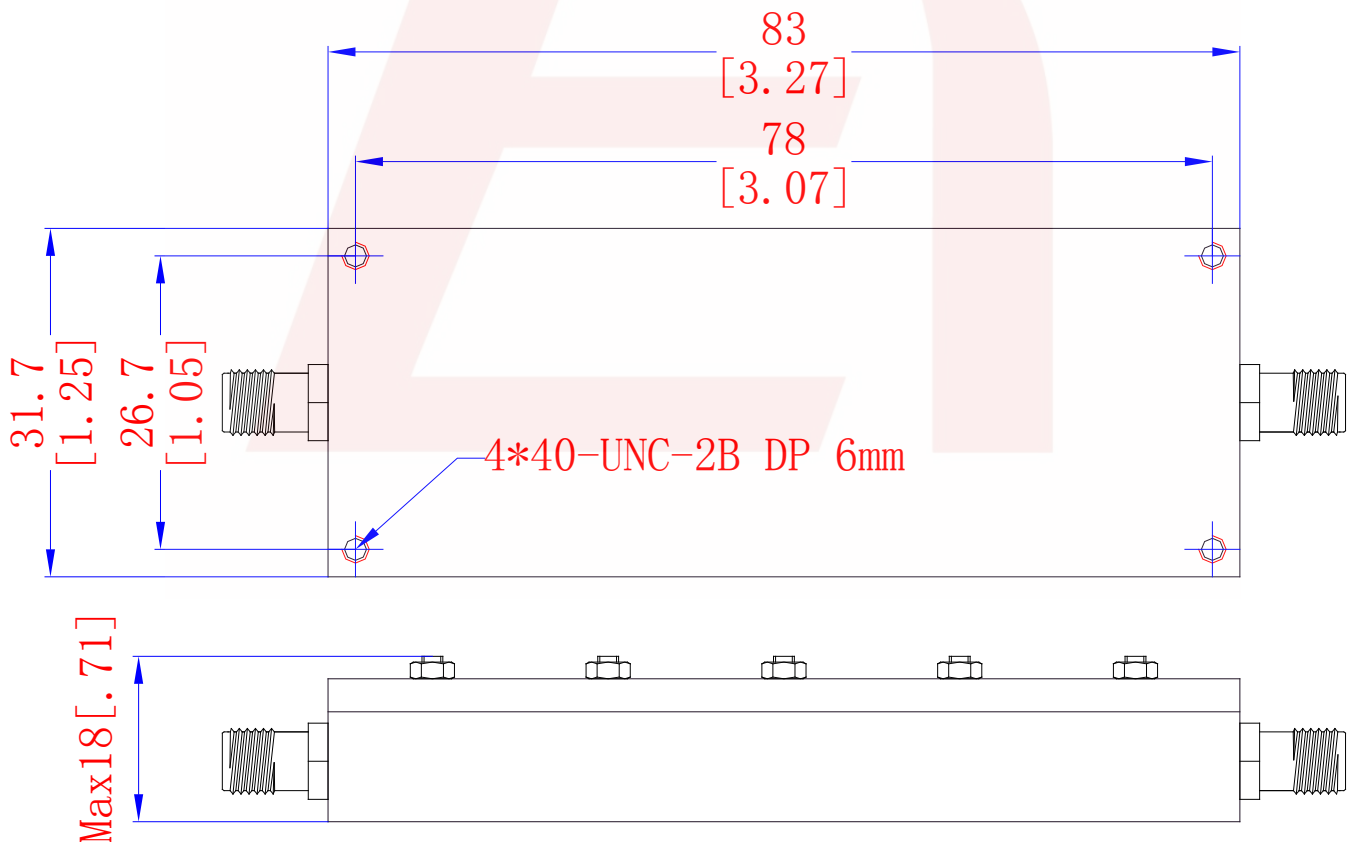

DS-B1240-03152018-Rev0