

## ISL8033EVAL1Z, ISL8033AEVAL1Z

Dual 3A Low Quiescent Current High Efficiency Synchronous Buck Regulator

AN1606  
Rev 1.00  
May 12, 2016

### Description

The ISL8033EVAL1Z, ISL8033AEVAL1Z evaluation boards are intended for use by individuals with requirements for point of load applications sourcing from 2.85V to 6V. The ISL8033EVAL1Z and ISL8033AEVAL1Z boards are used to demonstrate the performance of the ISL8033 and ISL8033A low quiescent current mode converters.

The [ISL8033](#) and [ISL8033A](#) are offered in a 4mmx4mm 24 Ld QFN package with 1mm maximum height. The complete converter occupies less than 5.46cm<sup>2</sup> area.

### Key Features

- Dual 3A high efficiency synchronous buck regulator with up to 95% efficiency
- 180° out-of-phase
- Power-Good (PG) output with 1ms delay
- 2.85V to 6V supply voltage
- 2% output accuracy over temperature/load/line
- Start-up with pre-biased output
- Internal digital soft-start - 1.5ms
- Soft-stop output discharge during disabled
- External synchronization up to 6MHz
- Typical 8µA logic controlled shutdown current
- 100% maximum duty cycle for lowest dropout
- Internal current mode compensation
- Peak current limiting, hiccup mode short-circuit protection and over-temperature protection
- Negative current detection and protection

### Recommended Equipment

The following materials are recommended to perform testing:

- 0V to 10V power supply with at least 3A source current capability or 5V battery
- Electronic loads capable of sinking current up to 3A
- Digital Multimeters (DMMs)
- 100MHz quad-trace oscilloscope
- Signal generator

### Quick Setup Guide

1. Ensure that the circuit is correctly connected to the supply and loads prior to applying any power.
2. Connect the bias supply to VIN1, the plus terminal to VIN1 and the negative return to PGND1.
3. Verify that position is ON for SW2 and SW3.
4. Turn on the power supply.
5. Verify the output voltage is 1.8V for VOUT1 and 1.8V for VOUT2.

### Evaluating the Other Output Voltage

The ISL8033EVAL1Z and ISL8033AEVAL1Z outputs are preset to 1.8V for VOUT1 and 1.8V for VOUT2; however, output voltages can be adjusted from 0.8V to 3.3V. The output voltage programming resistor, R2 (or R5 in Channel 2), will depend on the desired output voltage of the regulator. The value for the feedback resistor is typically between 0Ω and 750kΩ as shown in [Equation 1](#).

Let's set R3/R6 = 100kΩ then R2/R5 will be:

$$R_2 = R_3 \left( \frac{V_{OUT}}{V_{FB}} - 1 \right) \tag{EQ. 1}$$

If the output voltage desired is 0.8V, then leave R3 unpopulated and short R2. For faster response performance, add 47pF in parallel to R2.

### Mode Control

The ISL8033 and ISL8033A have a SYNC pin. Connect to logic high or input voltage VIN for PWM internal synchronization. Connect to an external function generator for external synchronization. Negative edge trigger. Do not leave this pin floating. Do not tie this pin low (or to GND).

TABLE 1. SWITCH SETTINGS

SW2, SW3	ENABLE	ON/OFF CONTROL
1	OFF	Disable VOUT
3	ON	Enable VOUT

### Ordering Information

PART NUMBER	DESCRIPTION
ISL8033EVAL1Z	Dual 1MHz, 3A per channel non-current sharing regulator evaluation board
ISL8033AEVAL1Z	Dual 2.25MHz, 3A per channel non-current sharing regulator evaluation board

# ISL8033EVAL1Z, ISL8033AEVAL1Z Schematics

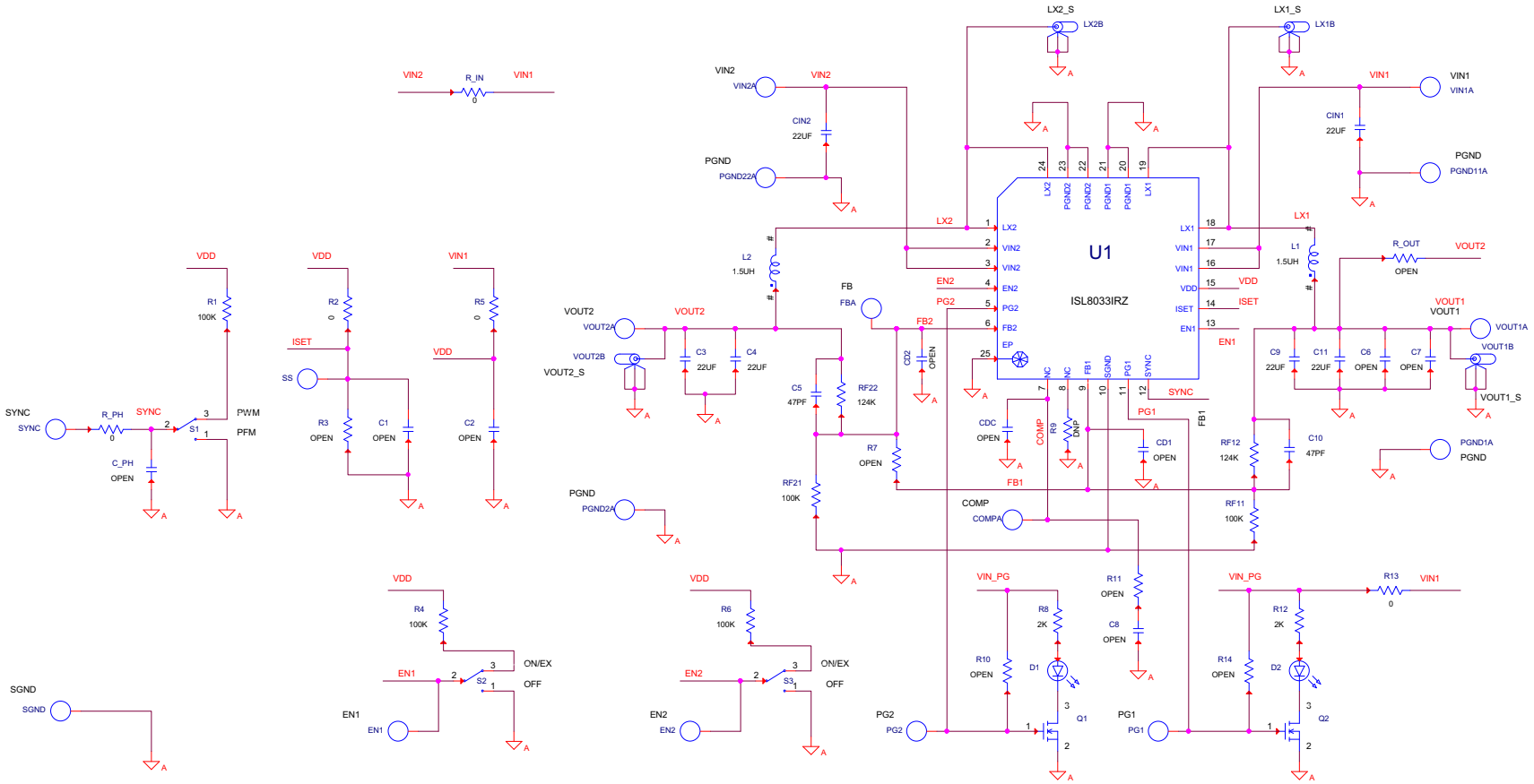

NOTE:  
 PLEASE KEEP FB1, FB2 PINS TRACES SHORT  
 PLEASE KEEP COMP PIN TRACES SHORT (TO C8, R13)

FIGURE 1. ISL8033EVAL1Z SCHEMATIC

# ISL8033EVAL1Z, ISL8033AEVAL1Z Schematics (Continued)

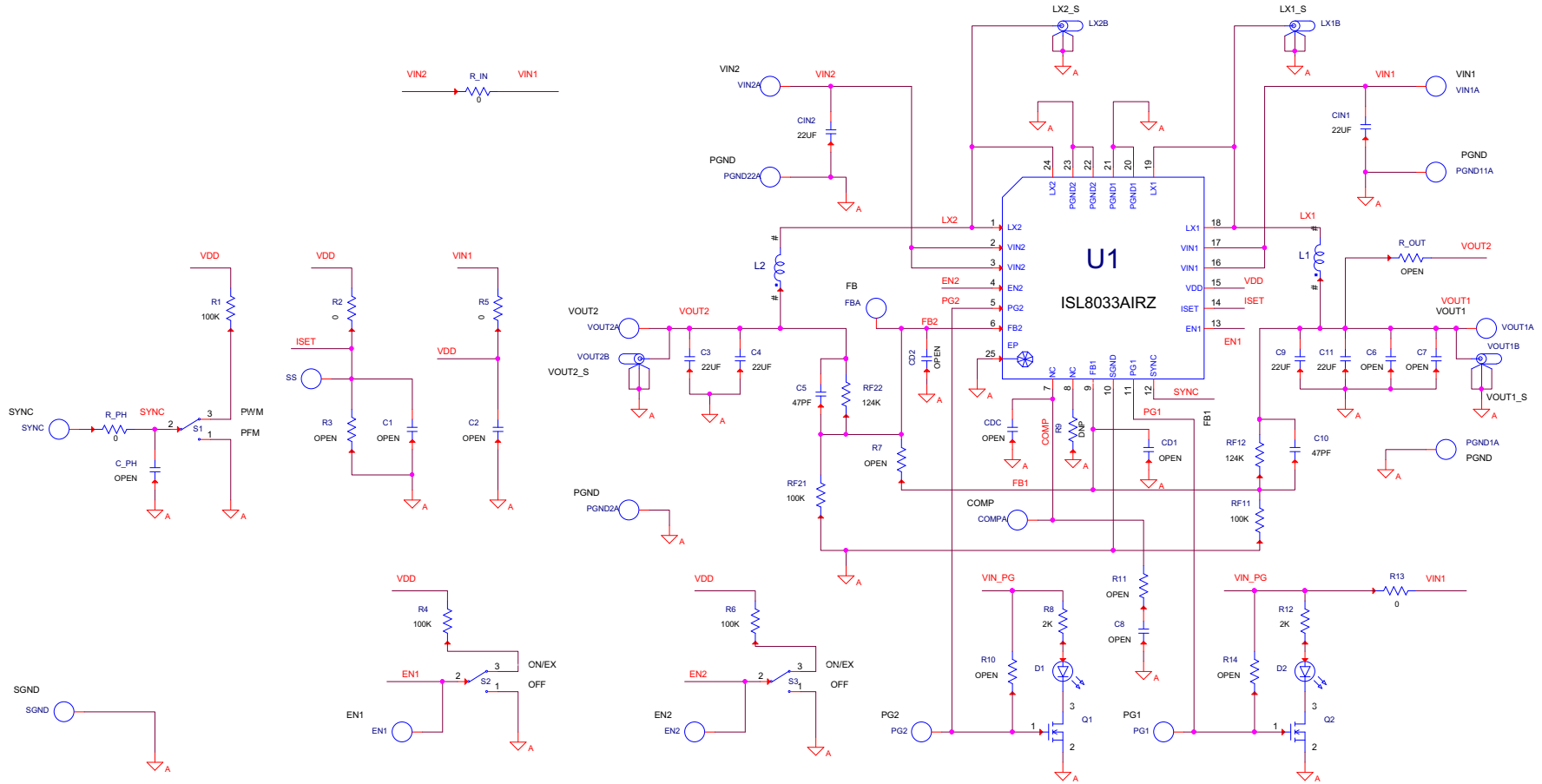

**NOTE:**

- PLEASE KEEP FB1, FB2 PINS TRACES SHORT
- PLEASE KEEP COMP PIN TRACES SHORT (TO C8, R13)

**FIGURE 2. ISL8033AEVAL1Z SCHEMATIC**

TABLE 2. BILL OF MATERIALS

PART NUMBER	QTY	UNITS	REFERENCE DESIGNATOR	DESCRIPTION	MANUFACTURER	MANUFACTURER PART
ISL8033_36EVAL1ZREVAPCB	1	ea.	a) PUT "X" IN ISL8033 BOX ON PCB	PWB-PCB, ISL8033_36EVAL1Z, REVA, ROHS	IMAGINEERING INC.	ISL8033_36EVAL1ZREVAPCB
ISL8033_36EVAL1ZREVAPCB	0	ea.	b) SEE LABEL-RENAME BOARD	PWB-PCB, ISL8033_36EVAL1Z, REVA, ROHS	IMAGINEERING INC.	ISL8033_36EVAL1ZREVAPCB
C2012X5R0J226M-T	6	ea.	C3, C4, C9, C11, CIN1, CIN2	CAP, SMD, 0805, 22µF, 6.3V, 20%, X5R, ROHS	TDK	C2012X5R0J226M
H1045-00120-50V5-T	2	ea.	C5, C10	CAP, SMD, 0603, 12pF, 50V, 5%, COG, ROHS	AVX	06035A120JAT2A
H1045-DNP	0	ea.	C1, C2, C8, CD1, CD2, CDC, C_PH	CAP, SMD, 0603, DNP-PLACE HOLDER, ROHS		
H1046-DNP	0	ea.	C6, C7	CAP, SMD, 0805, DNP-PLACE HOLDER, ROHS		
DR73-1R5-R (ISL8033)	2	ea.	L1, L2	COIL-PWR INDUCTOR, SMD, 7.5mm, 1.5µH, 20%, 6.52A, ROHS	COOPER ELECTRONIC TECH	DR73-1R5-R
FDV0630-R60M (ISL8033A)	2	ea.	L1, L2	Iron Powder Inductor, SMD, 7.4X6.7mm, 0.6µH, 20%, 10A, ROHS	TOKO	FDV0630-R60M
131-4353-00	4	ea.	LX1, LX2, VOUT1_S, VOUT2_S	CONN-SCOPE PROBE TEST PT, COMPACT, PCB MNT, ROHS	TEKTRONIX	131-4353-00
1514-2	8	ea.	a) PGND1, PGND2, PGND11, PGND22, VIN1, VIN2	CONN-TURRET, TERMINAL POST, TH, ROHS	KEYSTONE	1514-2
1514-2	0	ea.	b) VOUT1, VOUT2	CONN-TURRET, TERMINAL POST, TH, ROHS	KEYSTONE	1514-2
5000	6	ea.	a) EN1, EN2, PG1, PG2, SS, SYNC	CONN-MINI TEST PT, VERTICAL, RED, ROHS	KEYSTONE	5000
5000	0	ea.	b) SYNC located left of C_PH	CONN-MINI TEST PT, VERTICAL, RED, ROHS	KEYSTONE	5000
5001	1	ea.	SGND	CONN-MINI TEST PT, VERTICAL, BLK, ROHS	KEYSTONE	5001
5002	2	ea.	COMP, FB	CONN-MINI TEST PT, VERTICAL, WHITE, ROHS	KEYSTONE	5002
LTST-C170CKT	2	ea.	D1, D2	LED-GaAs RED, SMD, 2mmX1.25mm, 100mW, 40mA, 10mcd, ROHS	LITEON/VISHAY	LTST-C170CKT
ISL8033IRZ (ISL8033EVAL1Z)	1	ea.	U1	IC-DUAL 3A BUCK REGULATOR, 24P, QFN, 4X4, ROHS	INTERSIL	ISL8033IRZ
ISL8033AIRZ (ISL8033AEVAL1Z)						
2N7002-7-F-T	2	ea.	Q1, Q2	TRANSISTOR, N-CHANNEL, 3LD, SOT-23, 60V, 115mA, ROHS	DIODES, INC.	2N7002-7-F
H2509-DNP	1	ea.	R9	RES, SMD, 0201, 0Ω, 1/20W, 0%, TF		
H2511-00R00-1/10W-T	4	ea.	R2, R5, R13, R_PH	RES, SMD, 0603, 0Ω, 1/10W, TF, ROHS	VENKEL	CR0603-10W-000T
H2511-01003-1/10W1-T	5	ea.	R1, R4, R6, RF11, RF21	RES, SMD, 0603, 100k, 1/10W, 1%, TF, ROHS		

TABLE 2. BILL OF MATERIALS (Continued)

PART NUMBER	QTY	UNITS	REFERENCE DESIGNATOR	DESCRIPTION	MANUFACTURER	MANUFACTURER PART
H2511-01243-1/10W1-T	2	ea.	RF12, RF22	RES, SMD, 0603, 124k, 1/10W, 1%, TF, ROHS	YAGEO	9C06031A1243FKHFT
H2511-02001-1/10W1-T	2	ea.	R8, R12	RES, SMD, 0603, 2k, 1/10W, 1%, TF, ROHS	KOA	RK73H1JTTD2001F
H2511-DNP	0	ea.	R3, R7, R11, R10, R14	RES, SMD, 0603, DNP-PLACE HOLDER, ROHS		
H2514-00R00-1/4W-T	1	ea.	R_IN	RES, SMD, 1210, 0Ω, 1/4W, TF, ROHS	VENKEL	CR1210-4W-000
H2514-DNP	0	ea.	R_OUT	RES, SMD, 1210, DNP, DNP, DNP, TF, ROHS		
GT11MSCBE-T	3	ea.	S1-S3	SWITCH-TOGGLE, SMD, 6PIN, SPDT, 2POS, ON-ON, ROHS	ITT INDUSTRIES/C&K DIVISION	GT11MSCBE
SJ-5003-BLACK	4	ea.	Bottom four corners	BUMPONS, 0.44inW x 0.20inH, DOMETOP, BLACK	3M	SJ-5003SPBL
5X8-STATIC-BAG	1	ea.	Place assy in bag	BAG, STATIC, 5X8, ZIP LOC	INTERSIL	212403-013
LABEL-RENAME BOARD	1	ea.	RENAME PCB TO: ISL8033EVAL1Z	LABEL, TO RENAME BOARD	INTERSIL	LABEL-RENAME BOARD
LABEL-SERIAL NUMBER	1	ea.		LABEL, FOR SERIAL NUMBER AND BOM REV #		

## ISL8033EVAL1Z, ISL8033AEVAL1Z Board Layout

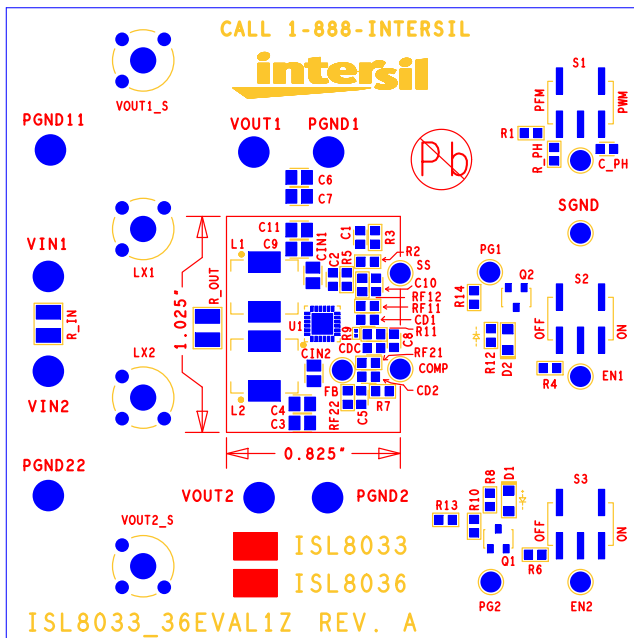

FIGURE 3. TOP COMPONENTS

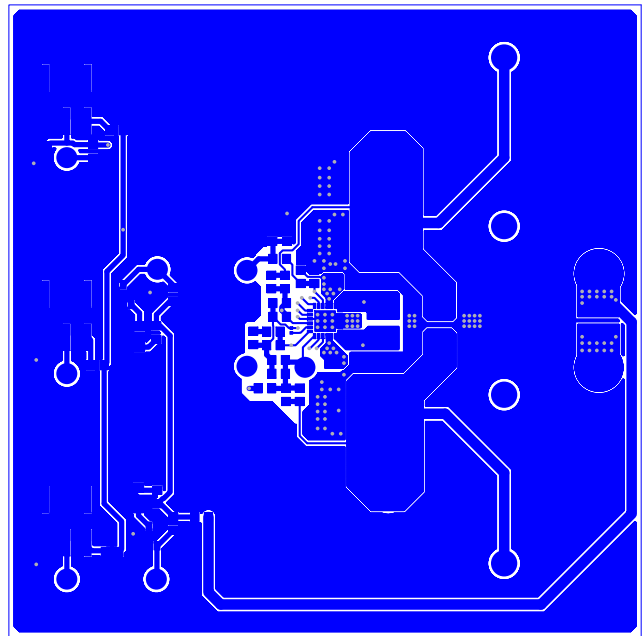

FIGURE 4. TOP LAYER ETCH

# ISL8033EVAL1Z, ISL8033AEVAL1Z Board Layout (Continued)

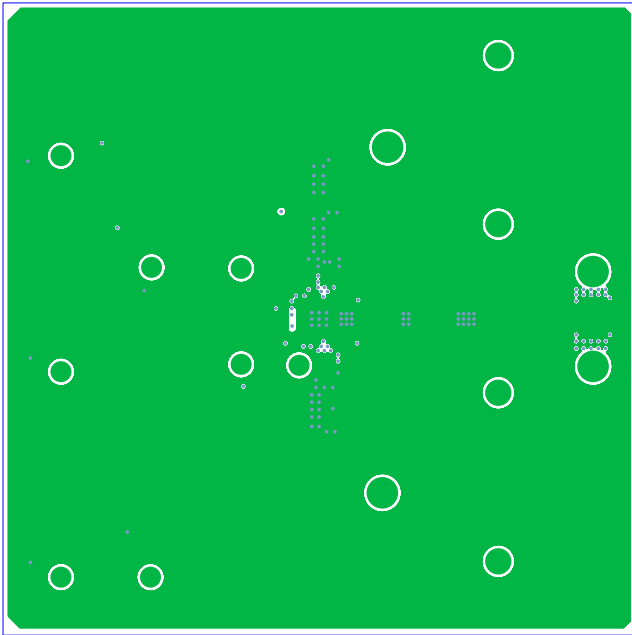

FIGURE 5. 2ND LAYER ETCH

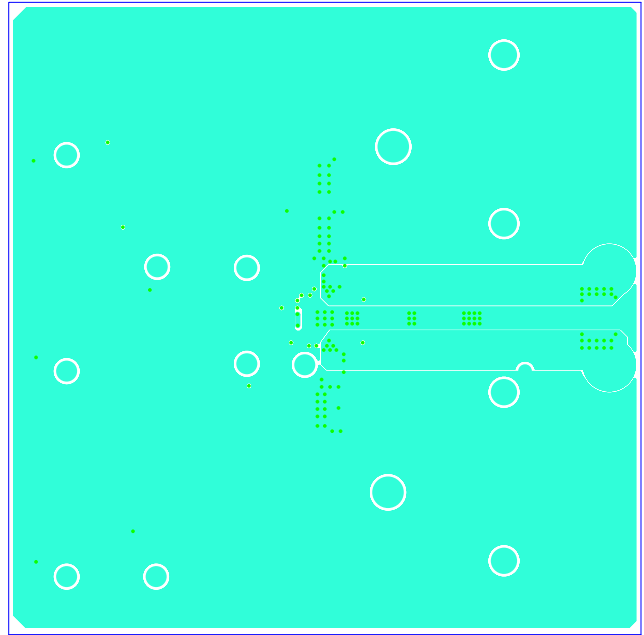

FIGURE 6. 3RD LAYER ETCH

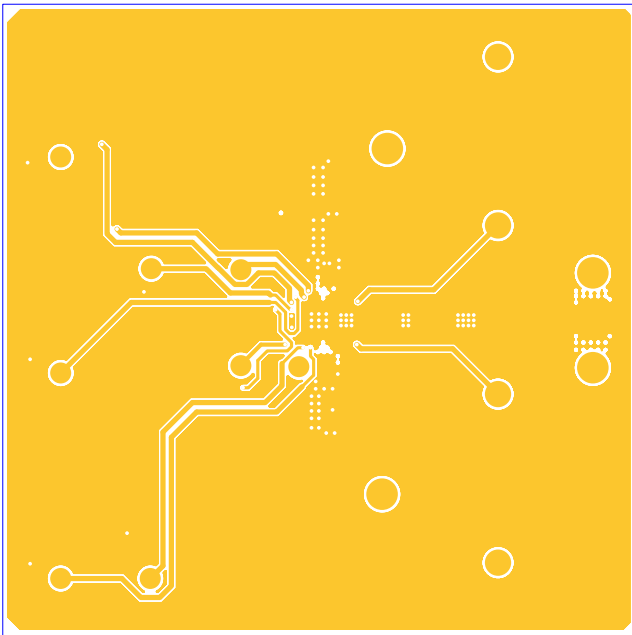

FIGURE 7. BOTTOM LAYER ETCH

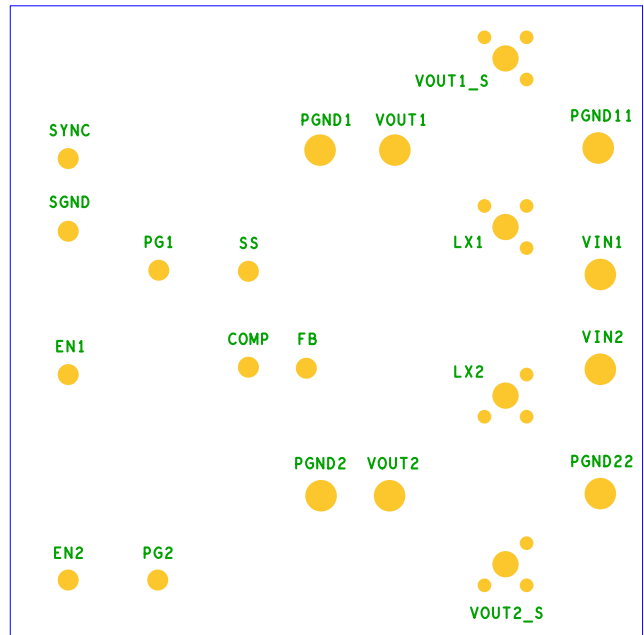

FIGURE 8. BOTTOM COMPONENTS (MIRROR)

## Notice

1. Descriptions of circuits, software and other related information in this document are provided only to illustrate the operation of semiconductor products and application examples. You are fully responsible for the incorporation or any other use of the circuits, software, and information in the design of your product or system. Renesas Electronics disclaims any and all liability for any losses and damages incurred by you or third parties arising from the use of these circuits, software, or information.
2. Renesas Electronics hereby expressly disclaims any warranties against and liability for infringement or any other claims involving patents, copyrights, or other intellectual property rights of third parties, by or arising from the use of Renesas Electronics products or technical information described in this document, including but not limited to, the product data, drawings, charts, programs, algorithms, and application examples.
3. No license, express, implied or otherwise, is granted hereby under any patents, copyrights or other intellectual property rights of Renesas Electronics or others.
4. You shall not alter, modify, copy, or reverse engineer any Renesas Electronics product, whether in whole or in part. Renesas Electronics disclaims any and all liability for any losses or damages incurred by you or third parties arising from such alteration, modification, copying or reverse engineering.
5. Renesas Electronics products are classified according to the following two quality grades: "Standard" and "High Quality". The intended applications for each Renesas Electronics product depends on the product's quality grade, as indicated below.  
"Standard": Computers; office equipment; communications equipment; test and measurement equipment; audio and visual equipment; home electronic appliances; machine tools; personal electronic equipment; industrial robots; etc.  
"High Quality": Transportation equipment (automobiles, trains, ships, etc.); traffic control (traffic lights); large-scale communication equipment; key financial terminal systems; safety control equipment; etc.  
Unless expressly designated as a high reliability product or a product for harsh environments in a Renesas Electronics data sheet or other Renesas Electronics document, Renesas Electronics products are not intended or authorized for use in products or systems that may pose a direct threat to human life or bodily injury (artificial life support devices or systems; surgical implantations; etc.), or may cause serious property damage (space system; undersea repeaters; nuclear power control systems; aircraft control systems; key plant systems; military equipment; etc.). Renesas Electronics disclaims any and all liability for any damages or losses incurred by you or any third parties arising from the use of any Renesas Electronics product that is inconsistent with any Renesas Electronics data sheet, user's manual or other Renesas Electronics document.
6. When using Renesas Electronics products, refer to the latest product information (data sheets, user's manuals, application notes, "General Notes for Handling and Using Semiconductor Devices" in the reliability handbook, etc.), and ensure that usage conditions are within the ranges specified by Renesas Electronics with respect to maximum ratings, operating power supply voltage range, heat dissipation characteristics, installation, etc. Renesas Electronics disclaims any and all liability for any malfunctions, failure or accident arising out of the use of Renesas Electronics products outside of such specified ranges.
7. Although Renesas Electronics endeavors to improve the quality and reliability of Renesas Electronics products, semiconductor products have specific characteristics, such as the occurrence of failure at a certain rate and malfunctions under certain use conditions. Unless designated as a high reliability product or a product for harsh environments in a Renesas Electronics data sheet or other Renesas Electronics document, Renesas Electronics products are not subject to radiation resistance design. You are responsible for implementing safety measures to guard against the possibility of bodily injury, injury or damage caused by fire, and/or danger to the public in the event of a failure or malfunction of Renesas Electronics products, such as safety design for hardware and software, including but not limited to redundancy, fire control and malfunction prevention, appropriate treatment for aging degradation or any other appropriate measures. Because the evaluation of microcomputer software alone is very difficult and impractical, you are responsible for evaluating the safety of the final products or systems manufactured by you.
8. Please contact a Renesas Electronics sales office for details as to environmental matters such as the environmental compatibility of each Renesas Electronics product. You are responsible for carefully and sufficiently investigating applicable laws and regulations that regulate the inclusion or use of controlled substances, including without limitation, the EU RoHS Directive, and using Renesas Electronics products in compliance with all these applicable laws and regulations. Renesas Electronics disclaims any and all liability for damages or losses occurring as a result of your noncompliance with applicable laws and regulations.
9. Renesas Electronics products and technologies shall not be used for or incorporated into any products or systems whose manufacture, use, or sale is prohibited under any applicable domestic or foreign laws or regulations. You shall comply with any applicable export control laws and regulations promulgated and administered by the governments of any countries asserting jurisdiction over the parties or transactions.
10. It is the responsibility of the buyer or distributor of Renesas Electronics products, or any other party who distributes, disposes of, or otherwise sells or transfers the product to a third party, to notify such third party in advance of the contents and conditions set forth in this document.
11. This document shall not be reprinted, reproduced or duplicated in any form, in whole or in part, without prior written consent of Renesas Electronics.
12. Please contact a Renesas Electronics sales office if you have any questions regarding the information contained in this document or Renesas Electronics products.  
(Note 1) "Renesas Electronics" as used in this document means Renesas Electronics Corporation and also includes its directly or indirectly controlled subsidiaries.  
(Note 2) "Renesas Electronics product(s)" means any product developed or manufactured by or for Renesas Electronics.

(Rev.4.0-1 November 2017)



### SALES OFFICES

Renesas Electronics Corporation

<http://www.renesas.com>

Refer to "<http://www.renesas.com/>" for the latest and detailed information.

**Renesas Electronics America Inc.**  
1001 Murphy Ranch Road, Milpitas, CA 95035, U.S.A.  
Tel: +1-408-432-8888, Fax: +1-408-434-5351

**Renesas Electronics Canada Limited**  
9251 Yonge Street, Suite 8309 Richmond Hill, Ontario Canada L4C 9T3  
Tel: +1-905-237-2004

**Renesas Electronics Europe Limited**  
Dukes Meadow, Millboard Road, Bourne End, Buckinghamshire, SL8 5FH, U.K  
Tel: +44-1628-651-700, Fax: +44-1628-651-804

**Renesas Electronics Europe GmbH**  
Arcadiastrasse 10, 40472 Düsseldorf, Germany  
Tel: +49-211-6503-0, Fax: +49-211-6503-1327

**Renesas Electronics (China) Co., Ltd.**  
Room 1709 Quantum Plaza, No.27 ZhichunLu, Haidian District, Beijing, 100191 P. R. China  
Tel: +86-10-8235-1155, Fax: +86-10-8235-7679

**Renesas Electronics (Shanghai) Co., Ltd.**  
Unit 301, Tower A, Central Towers, 555 Langao Road, Putuo District, Shanghai, 200333 P. R. China  
Tel: +86-21-2226-0888, Fax: +86-21-2226-0999

**Renesas Electronics Hong Kong Limited**  
Unit 1601-1611, 16/F., Tower 2, Grand Century Place, 193 Prince Edward Road West, Mongkok, Kowloon, Hong Kong  
Tel: +852-2265-6688, Fax: +852-2886-9022

**Renesas Electronics Taiwan Co., Ltd.**  
13F, No. 363, Fu Shing North Road, Taipei 10543, Taiwan  
Tel: +886-2-8175-9600, Fax: +886-2-8175-9670

**Renesas Electronics Singapore Pte. Ltd.**  
80 Bendemeer Road, Unit #06-02 Hyflux Innovation Centre, Singapore 339949  
Tel: +65-6213-0200, Fax: +65-6213-0300

**Renesas Electronics Malaysia Sdn.Bhd.**  
Unit 1207, Block B, Menara Amcorp, Amcorp Trade Centre, No. 18, Jln Persiaran Barat, 46050 Petaling Jaya, Selangor Darul Ehsan, Malaysia  
Tel: +60-3-7955-9390, Fax: +60-3-7955-9510

**Renesas Electronics India Pvt. Ltd.**  
No.777C, 100 Feet Road, HAL 2nd Stage, Indiranagar, Bangalore 560 038, India  
Tel: +91-80-67208700, Fax: +91-80-67208777

**Renesas Electronics Korea Co., Ltd.**  
17F, KAMCO Yangjae Tower, 262, Gangnam-daero, Gangnam-gu, Seoul, 06265 Korea  
Tel: +82-2-558-3737, Fax: +82-2-558-5338