

NHD-0420AZ-FL-YBW-33V3

Character Liquid Crystal Display Module

NHD- Newhaven Display
0420- 4 Lines x 20 Characters
AZ- Model
F- Transflective
L- Yellow/Green LED Backlight
Y- STN Yellow/Green
B- 6:00 Optimal View
W- Wide Temperature
33V3- 3.3 VDD, 3.0 Volt Backlight
RoHS Compliant

Newhaven Display International, Inc.

2661 Galvin Ct.

Elgin IL, 60124

Ph: 847-844-8795

Fax: 847-844-8796

www.newhavendisplay.com

nhtech@newhavendisplay.com

nhsales@newhavendisplay.com

Document Revision History

| Revision | Date | Description | Changed by |
|----------|----------|---|------------|
| 0 | 10/31/11 | 3.3V LCD Implemented | SB |
| 1 | 11/08/16 | Electrical Characteristics Updated | TM |
| 2 | 5/10/17 | Electrical Characteristics Updated | SB |
| 3 | 3/12/19 | V _{DD} Limits Fixed, Backlight Characteristics Updated | SB |

Functions and Features

- 4 lines x 20 characters
- Built-in controllers (ST7066U)
- +3.3V Power Supply
- 1/16 duty, 1/5 bias
- RoHS compliant

| SYMBOL | REVISION | DATE |
|--------|----------|------|
| | | |

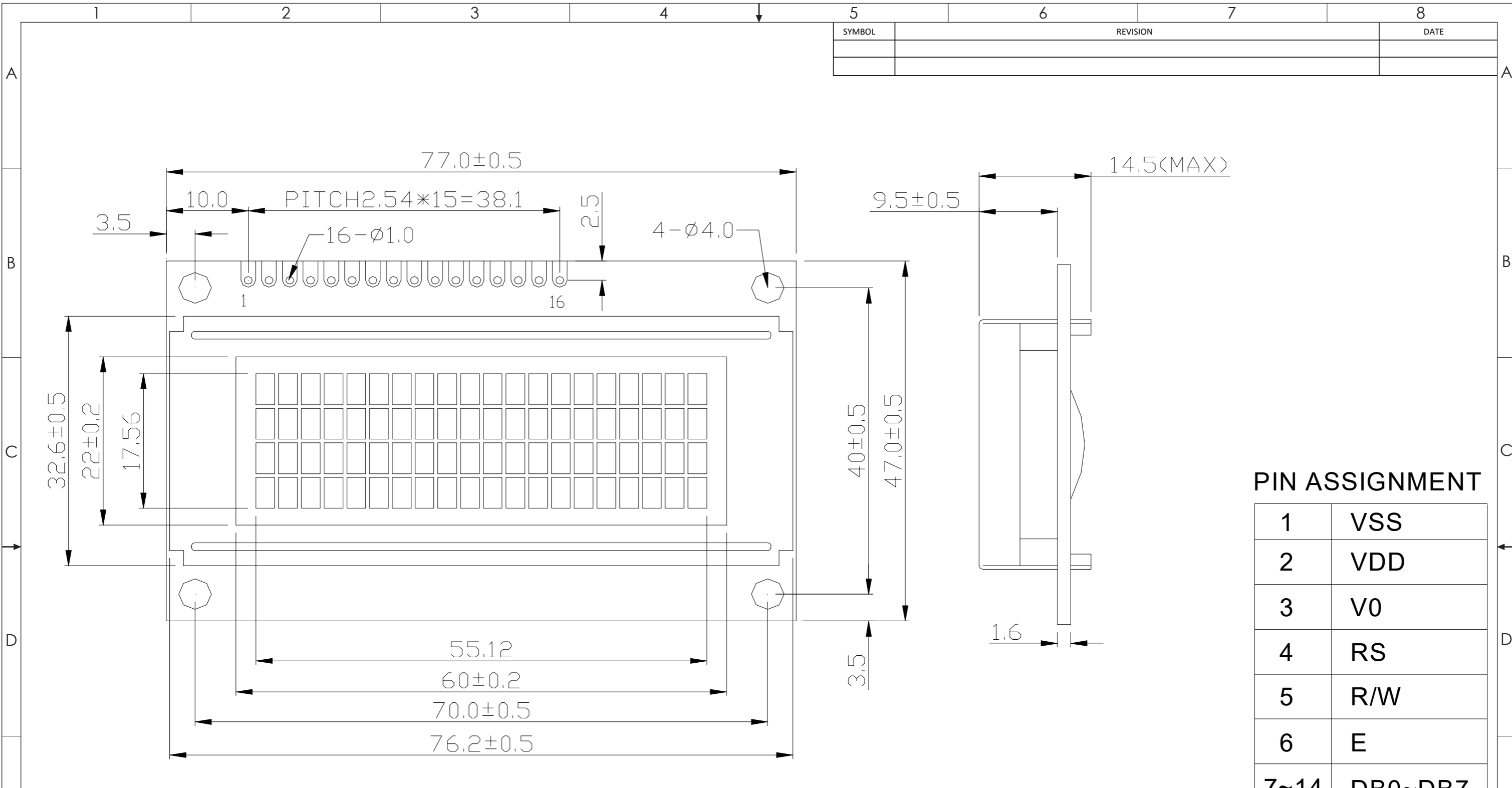

PIN ASSIGNMENT

| | |
|------|---------|
| 1 | VSS |
| 2 | VDD |
| 3 | V0 |
| 4 | RS |
| 5 | R/W |
| 6 | E |
| 7~14 | DB0~DB7 |
| 15 | LED+ |
| 16 | LED- |

- Notes:**
- 1. Driving: 1/16duty, 1/4bias
 - 2. Voltage: VDD 3.3V, VLCD 3.3V
 - 3. Display Type: STN Positive / Yellow-Green / Transflective
 - 4. Optimal View: 6:00
 - 5. Backlight: Yellow / Green LED
 - 6. Driver IC: ST7066U 4/ 8-bit MPU Interface

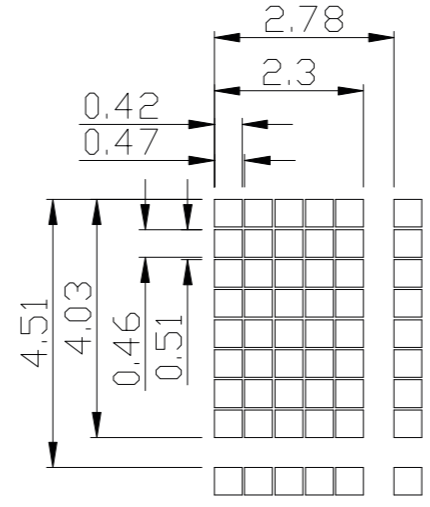

| | | |
|---|--------------------------------|---|
| STANDARD TOLERANCE: (UNLESS OTHERWISE SPECIFIED) | NEWHAVEN DISPLAY INTERNATIONAL | |
| | LINEAR: ±0.3mm | DRAWING/PART NUMBER: NHD-0420AZ-FL-YBW-33V3 |
| UNLESS OTHERWISE SPECIFIED: - DIMENSIONS ARE IN MILLIMETERS - THIRD ANGLE PROJECTION | DRAWN BY: S. Baxi | APPROVED BY: S. Baxi |
| | DRAWN DATE: 03/11/19 | APPROVED DATE: 03/11/19 |
| DO NOT SCALE DRAWING | | REVISION: 1.0 SIZE: A3 SCALE: NS |
| THIS DRAWING IS SOLELY THE PROPERTY OF NEWHAVEN DISPLAY INTERNATIONAL, INC. THE INFORMATION IT CONTAINS IS NOT TO BE DISCLOSED, REPRODUCED OR COPIED IN WHOLE OR PART WITHOUT WRITTEN APPROVAL FROM NEWHAVEN DISPLAY. | | |

Pin Description and Wiring Diagram

| Pin No. | Symbol | External Connection | Function Description |
|---------|-----------------|---------------------|--|
| 1 | V _{SS} | Power Supply | Ground |
| 2 | V _{DD} | Power Supply | Supply Voltage for logic (+3.3V) |
| 3 | V ₀ | Power Supply | Supply Voltage for contrast (approx. 0 V) |
| 4 | RS | MPU | Register Select signal. RS=0: Command, RS=1: Data |
| 5 | R/W | MPU | Read/Write select signal, R/W=1: Read R/W=0: Write |
| 6 | E | MPU | Operation Enable signal. Falling edge triggered. |
| 7-10 | DB0-DB3 | MPU | For low order bi-directional three-state data bus lines. These four are not used during 4-bit operation. |
| 11-14 | DB4-DB7 | MPU | Four high order bi-directional three-state data bus lines. |
| 15 | LED+ | Power Supply | Backlight Anode (+3.0V) |
| 16 | LED- | Power Supply | Backlight Cathode (Ground) |

Recommended LCD connector: 2.54mm pitch pins

Backlight connector: --- Mates with: ---

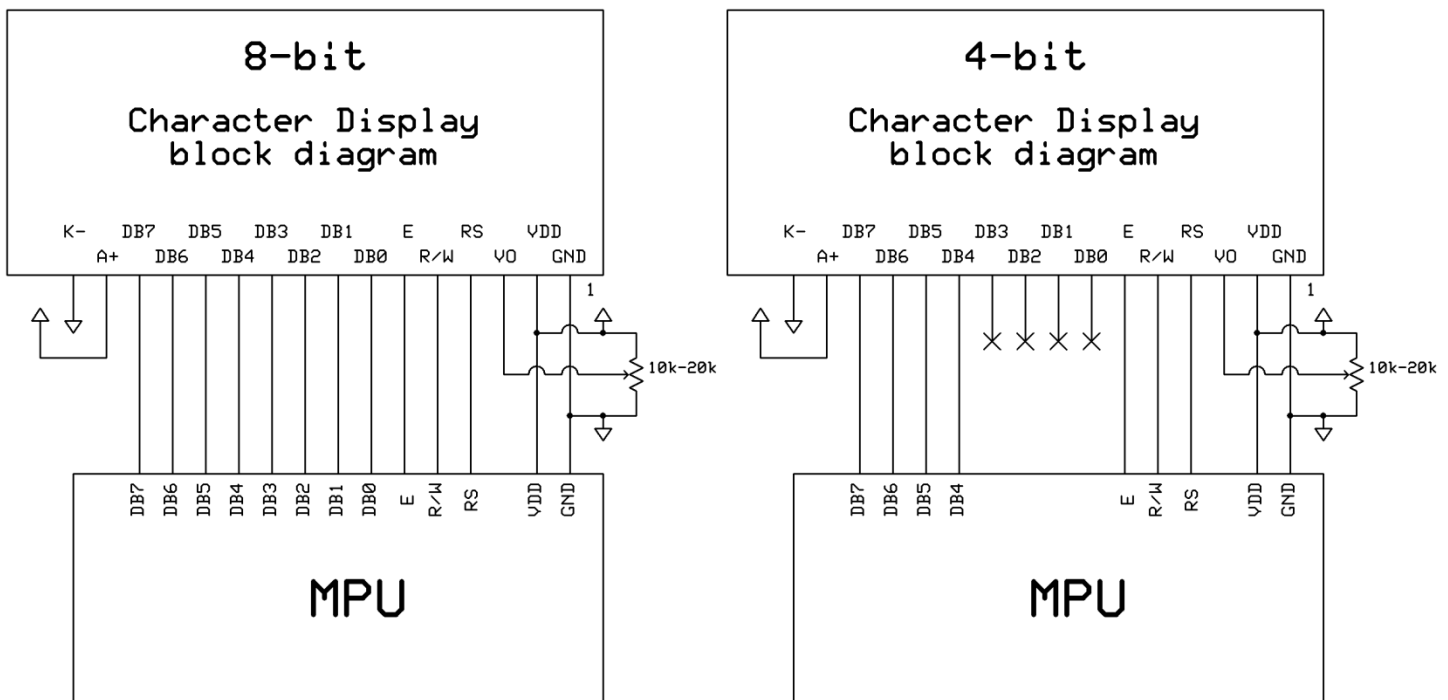

Electrical Characteristics

| Item | Symbol | Condition | Min. | Typ. | Max. | Unit |
|-----------------------------|------------------|---|------------------------|------|-----------------------|------|
| Operating Temperature Range | T _{OP} | Absolute Max | -20 | - | +70 | °C |
| Storage Temperature Range | T _{ST} | Absolute Max | -30 | - | +80 | °C |
| Supply Voltage | V _{DD} | - | 3.1 | 3.3 | 3.5 | V |
| Supply Current | I _{DD} | T _{OP} = 25°C, V _{DD} = 3.3V | 0.5 | 1.5 | 2.0 | mA |
| Supply for LCD (contrast) | V _{LCD} | | 3.1 | 3.3 | 3.5 | V |
| "H" Level input | V _{IH} | - | 0.7 * V _{DD} | - | V _{DD} | V |
| "L" Level input | V _{IL} | - | V _{SS} | - | 0.6 | V |
| "H" Level output | V _{OH} | - | 0.75 * V _{DD} | - | V _{DD} | V |
| "L" Level output | V _{OL} | - | V _{SS} | - | 0.2 * V _{DD} | V |
| Backlight Supply Voltage | V _{LED} | - | 2.8 | 3.0 | 3.2 | V |
| Backlight Supply Current | I _{LED} | V _{LED} = 3.0V | 200 | 280 | 350 | mA |

Optical Characteristics

| Item | Symbol | Condition | Min. | Typ. | Max. | Unit | |
|------------------------|--------|----------------|------------------------|------|------|------|----|
| Optimal Viewing Angles | Top | φY+ | CR ≥ 2 | - | 40 | - | ° |
| | Bottom | φY- | | - | 60 | - | ° |
| | Left | θX- | | - | 60 | - | ° |
| | Right | θX+ | | - | 60 | - | ° |
| Contrast Ratio | CR | - | 2 | 5 | - | - | |
| Response Time | Rise | T _R | T _{OP} = 25°C | - | 150 | 250 | ms |
| | Fall | T _F | | - | 200 | 300 | ms |

Controller Information

Built-in ST7066U Controller.

Please download specification at http://www.newhavendisplay.com/app_notes/ST7066U.pdf

DDRAM Address

| 1 | 2 | 3 | 4 | 5 | 6 | 7 | 8 | 9 | 10 | 11 | 12 | 13 | 14 | 15 | 16 | 17 | 18 | 19 | 20 |
|----|----|----|----|----|----|----|----|----|----|----|----|----|----|----|----|----|----|----|----|
| 00 | 01 | 02 | 03 | 04 | 05 | 06 | 07 | 08 | 09 | 0A | 0B | 0C | 0D | 0E | 0F | 10 | 11 | 12 | 13 |
| 40 | 41 | 42 | 43 | 44 | 45 | 46 | 47 | 48 | 49 | 4A | 4B | 4C | 4D | 4E | 4F | 50 | 51 | 52 | 53 |
| 14 | 15 | 16 | 17 | 18 | 19 | 1A | 1B | 1C | 1D | 1E | 1F | 20 | 21 | 22 | 23 | 24 | 25 | 26 | 27 |
| 54 | 55 | 56 | 57 | 58 | 59 | 5A | 5B | 5C | 5D | 5E | 5F | 60 | 61 | 62 | 63 | 64 | 65 | 66 | 67 |

Table of Commands

| Instruction | Instruction code | | | | | | | | | | Description | Execution time (fosc=270 KHZ) | |
|----------------------------|------------------|-----|-----|-----|-----|-----|-----|-----|-----|-----|-------------|--|--------|
| | RS | R/W | DB7 | DB6 | DB5 | DB4 | DB3 | DB2 | DB1 | DB0 | | | |
| Clear Display | 0 | 0 | 0 | 0 | 0 | 0 | 0 | 0 | 0 | 0 | 1 | Write "20H" to DDRAM and set DDRAM address to "00H" from AC | 1.52ms |
| Return Home | 0 | 0 | 0 | 0 | 0 | 0 | 0 | 0 | 0 | 1 | - | Set DDRAM Address to "00H" from AC and return cursor to its original position if shifted. The contents of DDRAM are not changed. | 1.52ms |
| Entry mode Set | 0 | 0 | 0 | 0 | 0 | 0 | 0 | 0 | 1 | I/D | SH | Sets cursor move direction and specifies display shift. These parameters are performed during data write and read. | 37μs |
| Display ON/OFF control | 0 | 0 | 0 | 0 | 0 | 0 | 0 | 1 | D | C | B | D=1: Entire display on C=1: Cursor on B=1: Blinking cursor on | 37μs |
| Cursor or Display shift | 0 | 0 | 0 | 0 | 0 | 0 | 1 | S/C | R/L | - | - | Sets cursor moving and display shift control bit, and the direction without changing DDRAM data. | 37μs |
| Function set | 0 | 0 | 0 | 0 | 1 | DL | N | F | - | - | - | DL: Interface data is 8/4 bits N: Number of lines is 2/1 F: Font size is 5x11/5x8 | 37μs |
| Set CGRAM Address | 0 | 0 | 0 | 1 | AC5 | AC4 | AC3 | AC2 | AC1 | AC0 | | Set CGRAM address in address counter | 37μs |
| Set DDRAM Address | 0 | 0 | 1 | AC6 | AC5 | AC4 | AC3 | AC2 | AC1 | AC0 | | Set DDRAM address in address counter. | 37μs |
| Read busy Flag and Address | 0 | 1 | BF | AC6 | AC5 | AC4 | AC3 | AC2 | AC1 | AC0 | | Whether during internal operation or not can be known by reading BF. The contents of address counter can also be read. | 0s |
| Write data To Address | 1 | 0 | D7 | D6 | D5 | D4 | D3 | D2 | D1 | D0 | | Write data into internal RAM (DDRAM/CGRAM). | 37μs |
| Read data From RAM | 1 | 1 | D7 | D6 | D5 | D4 | D3 | D2 | D1 | D0 | | Read data from internal RAM (DDRAM/CGRAM). | 37μs |

Timing Characteristics

Writing data from MPU to ST7066U

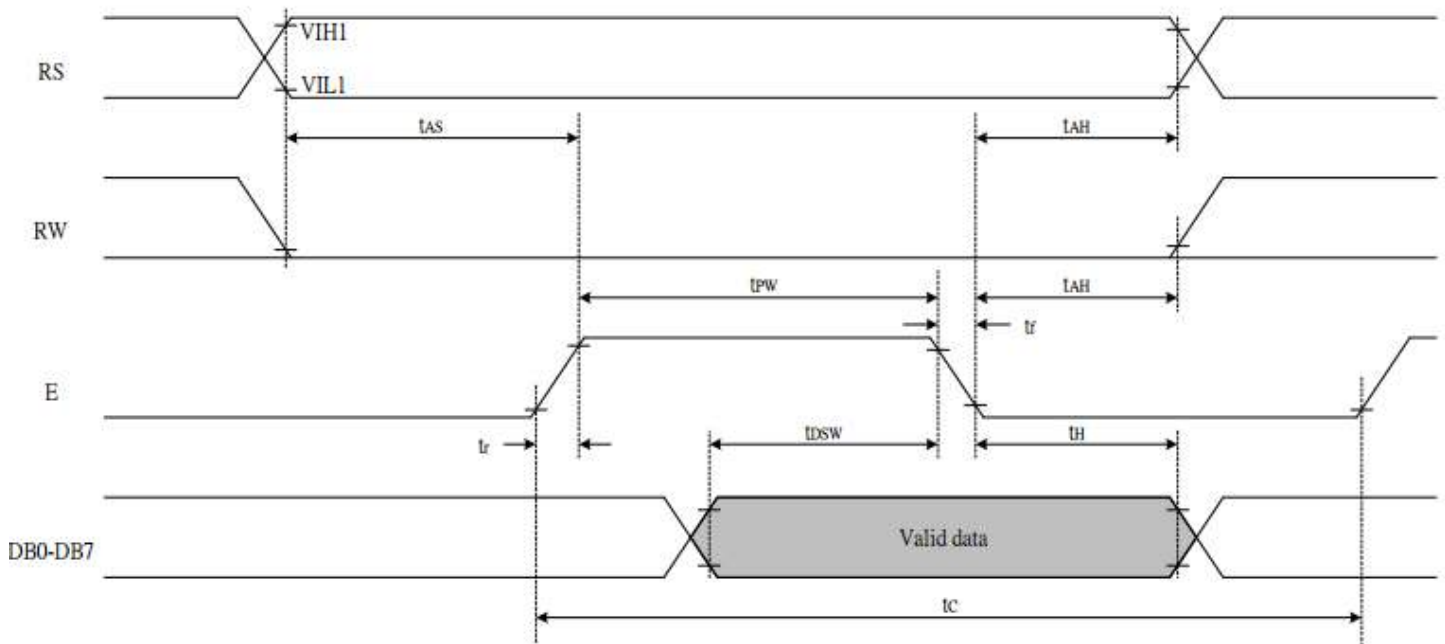

| Write Mode (Writing data from MPU to ST7066U) | | | | | | |
|---|-----------------------|-----------------|------|---|----|----|
| T_C | Enable Cycle Time | Pin E | 1200 | - | - | ns |
| T_{PW} | Enable Pulse Width | Pin E | 140 | - | - | ns |
| T_R, T_F | Enable Rise/Fall Time | Pin E | - | - | 25 | ns |
| T_{AS} | Address Setup Time | Pins: RS,RW,E | 0 | - | - | ns |
| T_{AH} | Address Hold Time | Pins: RS,RW,E | 10 | - | - | ns |
| T_{DSW} | Data Setup Time | Pins: DB0 - DB7 | 40 | - | - | ns |
| T_H | Data Hold Time | Pins: DB0 - DB7 | 10 | - | - | ns |

Reading data from ST7066U to MPU

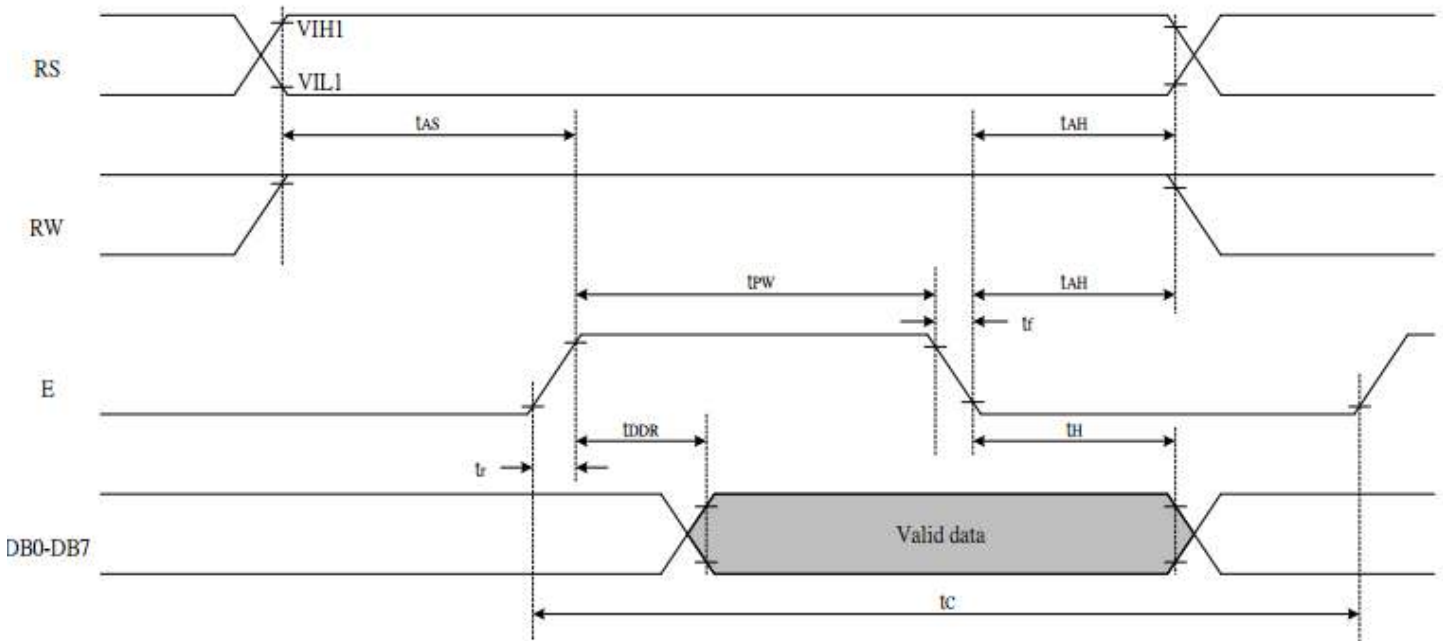

| Read Mode (Reading Data from ST7066U to MPU) | | | | | | |
|--|-----------------------|-----------------|------|---|-----|----|
| T_C | Enable Cycle Time | Pin E | 1200 | - | - | ns |
| T_{PW} | Enable Pulse Width | Pin E | 140 | - | - | ns |
| T_R, T_F | Enable Rise/Fall Time | Pin E | - | - | 25 | ns |
| T_{AS} | Address Setup Time | Pins: RS,RW,E | 0 | - | - | ns |
| T_{AH} | Address Hold Time | Pins: RS,RW,E | 10 | - | - | ns |
| T_{DDR} | Data Setup Time | Pins: DB0 - DB7 | - | - | 100 | ns |
| T_H | Data Hold Time | Pins: DB0 - DB7 | 10 | - | - | ns |

Built-in Font Table

| b7-b4 b3-b0 | 0000 | 0001 | 0010 | 0011 | 0100 | 0101 | 0110 | 0111 | 1000 | 1001 | 1010 | 1011 | 1100 | 1101 | 1110 | 1111 |
|----------------|------------------|------|------|------|------|------|------|------|------|------|------|------|------|------|------|------|
| 0000 | CG RAM (1) | | | 0 | a | P | ^ | F | | | | — | 9 | 3 | o | p |
| 0001 | (2) | ! | 1 | A | Q | a | A | | | | e | F | 7 | G | ä | g |
| 0010 | (3) | " | 2 | B | R | b | r | | | | " | Y | W | X | B | e |
| 0011 | (4) | # | 3 | C | S | c | s | | | | l | 9 | T | E | e | * |
| 0100 | (5) | * | 4 | D | T | d | t | | | | \ | I | f | P | H | a |
| 0101 | (6) | % | 5 | E | U | e | u | | | | . | + | * | 1 | o | 0 |
| 0110 | (7) | & | 6 | F | V | f | v | | | | 7 | 0 | 2 | 3 | P | Z |
| 0111 | (8) | ' | 7 | G | W | g | w | | | | 7 | * | X | 9 | g | n |
| 1000 | (1) | < | 8 | H | X | h | x | | | | 4 | 0 | * | U | J | X |
| 1001 | (2) | > | 9 | I | Y | i | y | | | | o | 7 | 7 | U | " | Y |
| 1010 | (3) | * | : | J | Z | j | z | | | | e | o | n | v | j | 7 |
| 1011 | (4) | + | : | K | L | k | l | | | | * | 9 | E | O | * | n |
| 1100 | (5) | , | < | L | * | l | l | | | | e | 9 | 7 | 7 | e | n |
| 1101 | (6) | — | = | M | J | m | j | | | | u | X | \ | 7 | t | ÷ |
| 1110 | (7) | . | > | N | ^ | n | → | | | | e | E | T | ° | n | |
| 1111 | (8) | / | ? | O | _ | o | ← | | | | e | U | 7 | " | o | ■ |

Example Initialization Program

8-bit Initialization:

```

/*****/
void command(char i)
{
    P1 = i;                //put data on output Port
    D_I =0;               //D/I=LOW : send instruction
    R_W =0;               //R/W=LOW : Write
    E = 1;
    Delay(1);             //enable pulse width >= 300ns
    E = 0;                 //Clock enable: falling edge
}
/*****/
void write(char i)
{
    P1 = i;                //put data on output Port
    D_I =1;               //D/I=HIGH : send data
    R_W =0;               //R/W=LOW : Write
    E = 1;
    Delay(1);             //enable pulse width >= 300ns
    E = 0;                 //Clock enable: falling edge
}
/*****/
void init()
{
    E = 0;
    Delay(100);           //Wait >40 msec after power is applied
    command(0x30);        //command 0x30 = Wake up
    Delay(30);            //must wait 5ms, busy flag not available
    command(0x30);        //command 0x30 = Wake up #2
    Delay(10);            //must wait 160us, busy flag not available
    command(0x30);        //command 0x30 = Wake up #3
    Delay(10);            //must wait 160us, busy flag not available
    command(0x38);        //Function set: 8-bit/2-line
    command(0x10);        //Set cursor
    command(0x0c);        //Display ON; Cursor ON
    command(0x06);        //Entry mode set
}
/*****/
```

4-bit Initialization:

```

/*****/
void command(char i)
{
    P1 = i;                //put data on output Port
    D_I = 0;              //D/I=LOW : send instruction
    R_W = 0;              //R/W=LOW : Write
    Nybble();             //Send lower 4 bits
    i = i<<4;             //Shift over by 4 bits
    P1 = i;                //put data on output Port
    Nybble();             //Send upper 4 bits
}
/*****/
void write(char i)
{
    P1 = i;                //put data on output Port
    D_I = 1;              //D/I=HIGH : send data
    R_W = 0;              //R/W=LOW : Write
    Nybble();             //Clock lower 4 bits
    i = i<<4;             //Shift over by 4 bits
    P1 = i;                //put data on output Port
    Nybble();             //Clock upper 4 bits
}
/*****/
void Nybble()
{
    E = 1;
    Delay(1);              //enable pulse width >= 300ns
    E = 0;                 //Clock enable: falling edge
}
/*****/
void init()
{
    P1 = 0;
    P3 = 0;
    Delay(100);            //Wait >40 msec after power is applied
    P1 = 0x30;             //put 0x30 on the output port
    Delay(30);             //must wait 5ms, busy flag not available
    Nybble();              //command 0x30 = Wake up
    Delay(10);             //must wait 160us, busy flag not available
    Nybble();              //command 0x30 = Wake up #2
    Delay(10);             //must wait 160us, busy flag not available
    Nybble();              //command 0x30 = Wake up #3
    Delay(10);             //can check busy flag now instead of delay
    P1= 0x20;              //put 0x20 on the output port
    Nybble();              //Function set: 4-bit interface
    command(0x28);         //Function set: 4-bit/2-line
    command(0x10);         //Set cursor
    command(0x0F);         //Display ON; Blinking cursor
    command(0x06);         //Entry Mode set
}
/*****/

```

Quality Information

| Test Item | Content of Test | Test Condition | Note |
|---------------------------------------|---|---|------|
| High Temperature storage | Endurance test applying the high storage temperature for a long time. | +80°C , 48hrs | 2 |
| Low Temperature storage | Endurance test applying the low storage temperature for a long time. | -30°C , 48hrs | 1,2 |
| High Temperature Operation | Endurance test applying the electric stress (voltage & current) and the high thermal stress for a long time. | +70°C , 48hrs | 2 |
| Low Temperature Operation | Endurance test applying the electric stress (voltage & current) and the low thermal stress for a long time. | -20°C , 48hrs | 1,2 |
| High Temperature / Humidity Operation | Endurance test applying the electric stress (voltage & current) and the high thermal with high humidity stress for a long time. | +40°C , 90% RH , 48hrs | 1,2 |
| Thermal Shock resistance | Endurance test applying the electric stress (voltage & current) during a cycle of low and high thermal stress. | 0°C, 30min -> 25°C, 5min -> 50°C, 30min = 1 cycle For 10 cycles | |
| Vibration test | Endurance test applying vibration to simulate transportation and use. | 10-55Hz, 1.5mm amplitude. 60 sec in each of 3 directions X,Y,Z For 15 minutes | 3 |
| Static electricity test | Endurance test applying electric static discharge. | VS=800V, RS=1.5kΩ, CS=100pF One time | |

Note 1: No condensation to be observed.

Note 2: Conducted after 4 hours of storage at 25°C, 0%RH.

Note 3: Test performed on product itself, not inside a container.

Precautions for using LCDs/LCMs

See Precautions at www.newhavendisplay.com/specs/precautions.pdf

Warranty Information and Terms & Conditions

http://www.newhavendisplay.com/index.php?main_page=terms