

CONSTANT VOLTAGE AND CONSTANT CURRENT CONTROLLER

Description

The AP4305 is a highly integrated solution for a constant voltage/constant current mode SMPS application.

The AP4305 contains one 1.21V voltage reference with ±0.5% accuracy, one current sensing circuit and two operational amplifiers. Combining the voltage reference with one operational amplifier makes AP4305 an ideal voltage controller for use in adapters and battery chargers. The other low voltage reference combined with the other operational amplifier makes it an ideal current limiter for output low side current sensing.

The AP4305 is available in SOT26 package.

Features

- Constant Voltage and Constant Current Control
- Precision Internal Voltage Reference
- Few External Components
- Easy Compensation
- Low Supply Current: 0.5mA
- Operating Temperature Range: -40 to +105°C
- **Totally Lead-free & Fully RoHS Compliant (Notes 1 & 2)**
- **Halogen and Antimony Free. "Green" Device (Note 3)**

Notes: 1. No purposely added lead. Fully EU Directive 2002/95/EC (RoHS) & 2011/65/EU (RoHS 2) compliant.
 2. See http://www.diodes.com/quality/lead_free.html for more information about Diodes Incorporated's definitions of Halogen- and Antimony-free, "Green" and Lead-free.
 3. Halogen- and Antimony-free "Green" products are defined as those which contain <900ppm bromine, <900ppm chlorine (<1500ppm total Br + Cl) and <1000ppm antimony compounds.

Pin Assignments

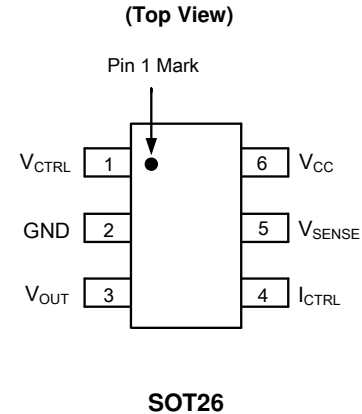

Applications

- Adapters
- Battery Chargers

Typical Applications Circuit

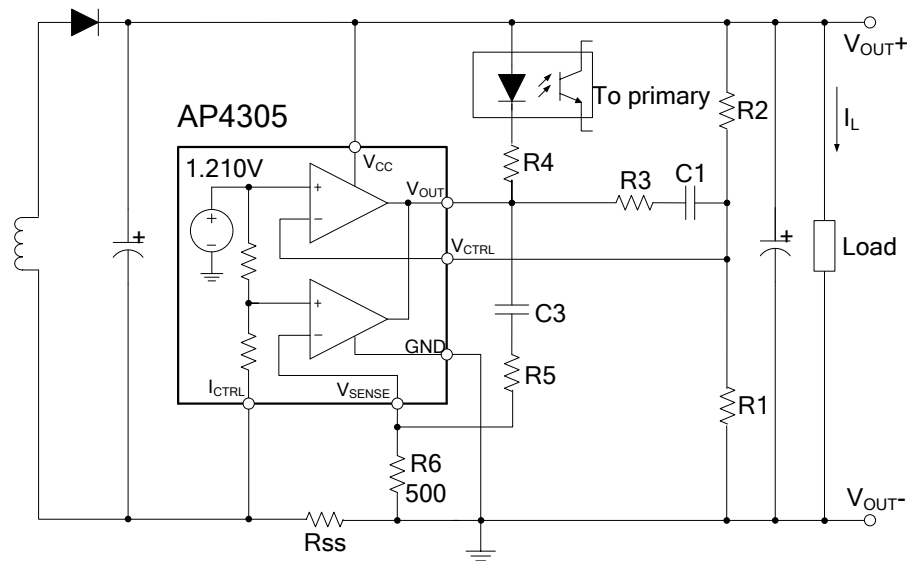

$$V_{OUT} = V_{REF} \times \frac{R1 + R2}{R1} (V)$$

$$CurrentLimit = \frac{V_{SENSE}}{R_{SS}} (A)$$

Typical Application 1

Pin Descriptions

Pin Number	Pin Name	Function
1	V_{CTRL}	Input pin of the voltage control loop
2	GND	Ground
3	V_{OUT}	Output pin. Sinking current only
4	I_{CTRL}	Input pin of the current control loop
5	V_{SENSE}	Input pin of the current control loop
6	V_{CC}	Power supply

Functional Block Diagram

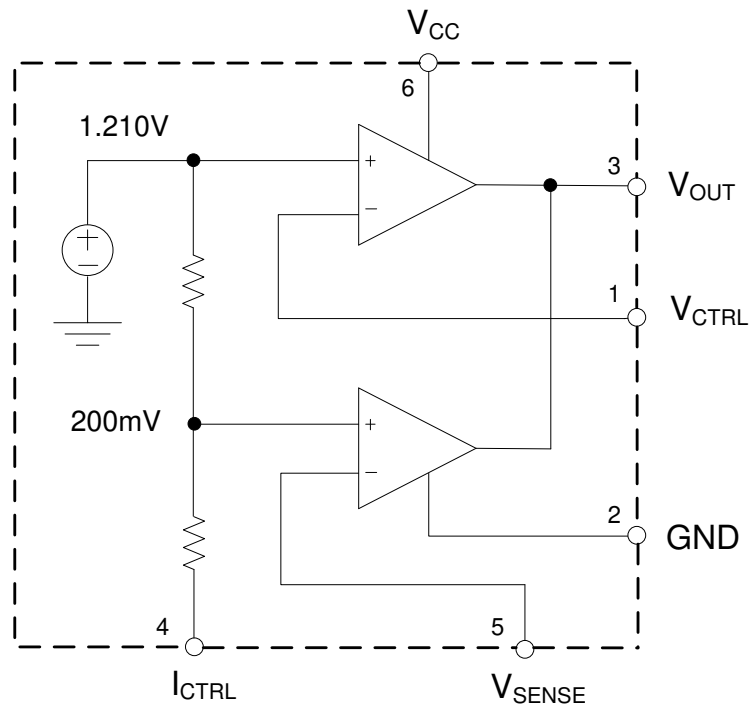

Absolute Maximum Ratings (Note 4)

Symbol	Parameter	Rating	Unit
V_{CC}	Power Supply Voltage	20	V
V_{IN}	Input Voltage	-0.3 to V_{CC}	V
T_J	Junction Temperature	+150	°C
T_{STG}	Storage Temperature	-65 to +150	°C
T_{LEAD}	Lead Temperature (Soldering, 5sec)	+260	°C
θ_{JC}	Package Thermal Resistance (Junction to Case)	92	°C/W

Note 4: Stresses greater than those listed under "Absolute Maximum Ratings" may cause permanent damage to the device. These are stress ratings only, and functional operation of the device at these or any other conditions beyond those indicated under "Recommended Operating Conditions" is not implied. Exposure to "Absolute Maximum Ratings" for extended periods may affect device reliability.

Recommended Operating Conditions

Symbol	Parameter	Min	Max	Unit
V_{CC}	Power Supply Voltage	2.5	18	V
T_A	Operating Temperature Range	-40	+105	°C

Electrical Characteristics ($V_{CC}=5V$, $T_A=+25^{\circ}C$, unless otherwise specified.)

Symbol	Parameter	Conditions	Min	Typ	Max	Unit
TOTAL CURRENT CONSUMPTION						
I_{CC}	Total Supply Current Not Including the Output Sinking Current	$T_A=+25^{\circ}C$	-	0.5	1	mA
		$-40^{\circ}C < T_A < +105^{\circ}C$	-	0.6	-	
VOLTAGE CONTROL LOOP						
G_{mv}	Transconduction Gain (V_{CTRL}). Sink Current Only	$T_A=+25^{\circ}C$	1	3.5	-	mA/mV
		$-40^{\circ}C < T_A < +105^{\circ}C$	-	2.5	-	
V_{REF}	Voltage Control Loop Reference	$T_A=+25^{\circ}C$	1.204	1.21	1.216	V
		$-40^{\circ}C < T_A < +105^{\circ}C$	1.186	-	1.234	
I_{IBV}	Input Bias Current (V_{CTRL})	$T_A=+25^{\circ}C$	-	50	-	nA
		$-40^{\circ}C < T_A < +105^{\circ}C$	-	100	-	
CURRENT CONTROL LOOP						
G_{mi}	Transconduction Gain (I_{CTRL}). Sink Current Only	$T_A=+25^{\circ}C$	1.5	7	-	mA/mV
V_{SENSE}	Current Control Loop Reference	$I_{OUT}=2.5mA$, $T_A=+25^{\circ}C$	198	200	202	mV
		$I_{OUT}=2.5mA$, $-40^{\circ}C < T_A < +105^{\circ}C$	192	-	208	
I_{IBI}	Current Out of Pin I_{CTRL} at 200mV	$T_A=+25^{\circ}C$	-	25	-	μA
		$-40^{\circ}C < T_A < +105^{\circ}C$	-	50	-	
OUTPUT STAGE						
V_{OL}	Low Output Voltage at 10mA Sinking Current	$T_A=+25^{\circ}C$	-	200	-	mV
I_{OS}	Output Short Circuit Current. Output to V_{CC} , Sink Current Only	$T_A=+25^{\circ}C$	-	27	50	mA
		$-40^{\circ}C < T_A < +105^{\circ}C$	-	35	-	

Performance Characteristics

V_{REF} vs. Ambient Temperature

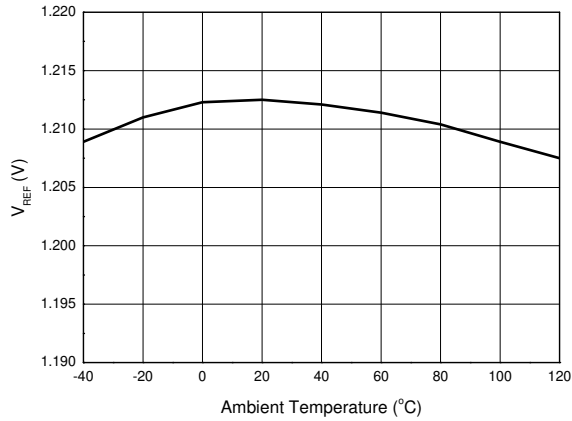

V_{SENSE} vs. Ambient Temperature

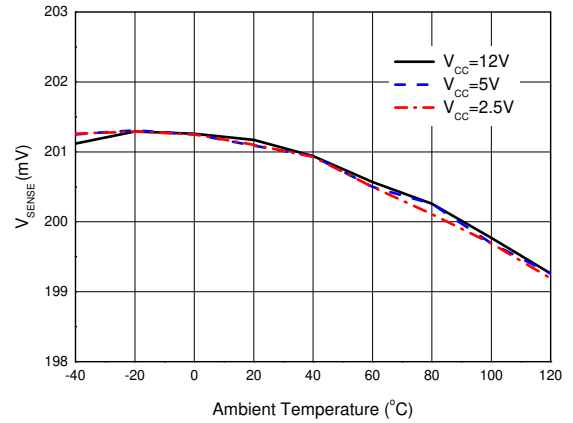

I_{IBV} vs. Ambient Temperature

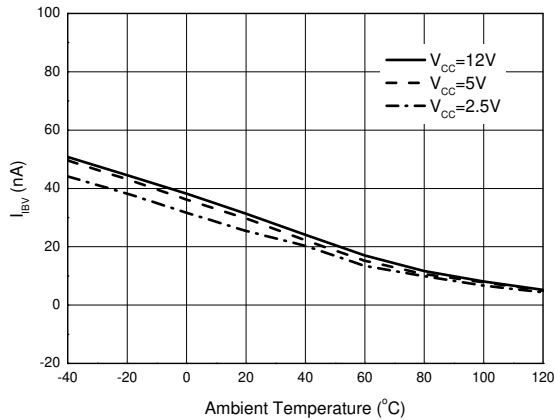

I_{IBI} vs. Ambient Temperature

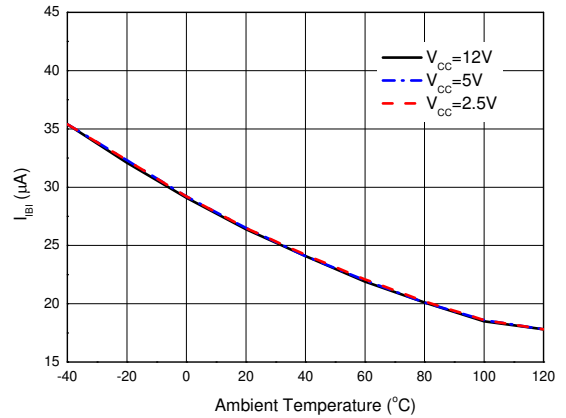

Output Short Circuit Current vs. Ambient Temperature

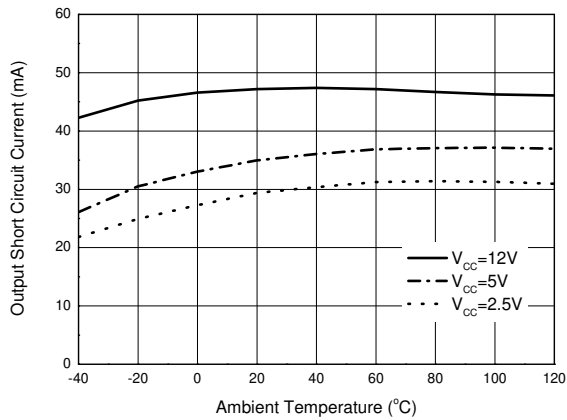

Supply Current vs. Ambient Temperature

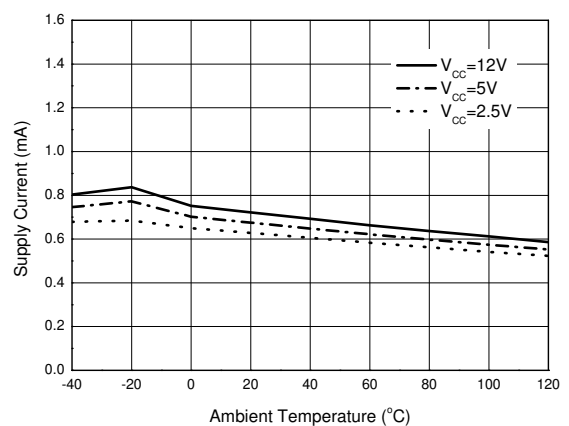

Ordering Information

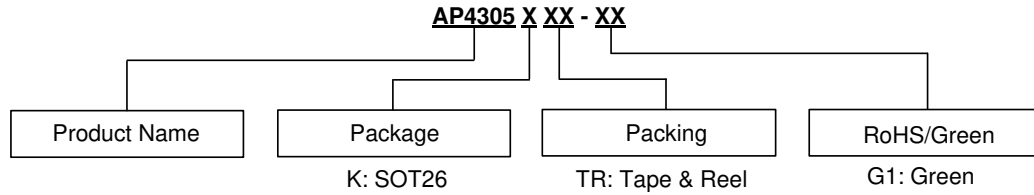

Package	Temperature Range	Part Number	Marking ID	Packing
SOT26	-40 to +105°C	AP4305KTR-G1	G2B	3000/Tape & Reel

Marking Information

(Top View)

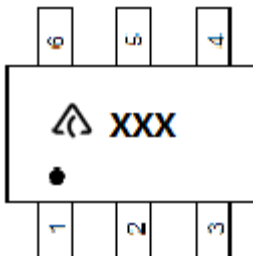

 : Logo
 XXX: Marking ID (See Ordering Information)

Package Outline Dimensions (All dimensions in mm(inch).)

(1) Package Type: SOT26

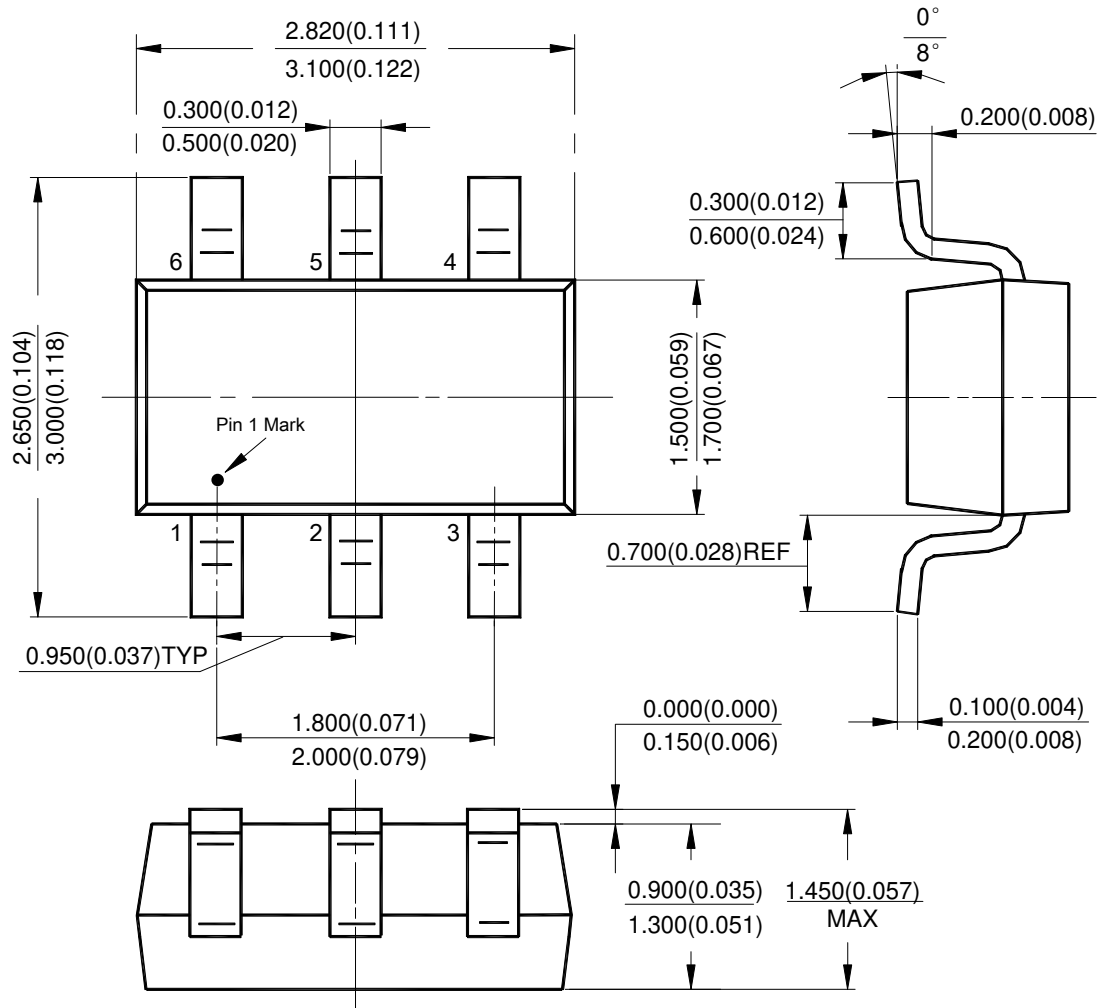

Suggested Pad Layout

(1) Package Type: SOT26

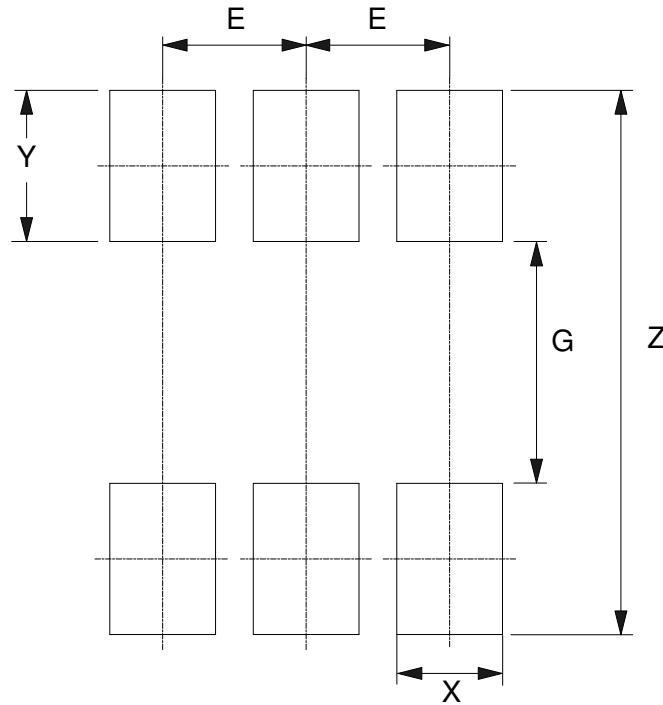

Dimensions	Z (mm)/(inch)	G (mm)/(inch)	X (mm)/(inch)	Y (mm)/(inch)	E (mm)/(inch)
Value	3.600/0.142	1.600/0.063	0.700/0.028	1.000/0.039	0.950/0.037

IMPORTANT NOTICE

DIODES INCORPORATED MAKES NO WARRANTY OF ANY KIND, EXPRESS OR IMPLIED, WITH REGARDS TO THIS DOCUMENT, INCLUDING, BUT NOT LIMITED TO, THE IMPLIED WARRANTIES OF MERCHANTABILITY AND FITNESS FOR A PARTICULAR PURPOSE (AND THEIR EQUIVALENTS UNDER THE LAWS OF ANY JURISDICTION).

Diodes Incorporated and its subsidiaries reserve the right to make modifications, enhancements, improvements, corrections or other changes without further notice to this document and any product described herein. Diodes Incorporated does not assume any liability arising out of the application or use of this document or any product described herein; neither does Diodes Incorporated convey any license under its patent or trademark rights, nor the rights of others. Any Customer or user of this document or products described herein in such applications shall assume all risks of such use and will agree to hold Diodes Incorporated and all the companies whose products are represented on Diodes Incorporated website, harmless against all damages.

Diodes Incorporated does not warrant or accept any liability whatsoever in respect of any products purchased through unauthorized sales channel. Should Customers purchase or use Diodes Incorporated products for any unintended or unauthorized application, Customers shall indemnify and hold Diodes Incorporated and its representatives harmless against all claims, damages, expenses, and attorney fees arising out of, directly or indirectly, any claim of personal injury or death associated with such unintended or unauthorized application.

Products described herein may be covered by one or more United States, international or foreign patents pending. Product names and markings noted herein may also be covered by one or more United States, international or foreign trademarks.

This document is written in English but may be translated into multiple languages for reference. Only the English version of this document is the final and determinative format released by Diodes Incorporated.

LIFE SUPPORT

Diodes Incorporated products are specifically not authorized for use as critical components in life support devices or systems without the express written approval of the Chief Executive Officer of Diodes Incorporated. As used herein:

A. Life support devices or systems are devices or systems which:

1. are intended to implant into the body, or
2. support or sustain life and whose failure to perform when properly used in accordance with instructions for use provided in the labeling can be reasonably expected to result in significant injury to the user.

B. A critical component is any component in a life support device or system whose failure to perform can be reasonably expected to cause the failure of the life support device or to affect its safety or effectiveness.

Customers represent that they have all necessary expertise in the safety and regulatory ramifications of their life support devices or systems, and acknowledge and agree that they are solely responsible for all legal, regulatory and safety-related requirements concerning their products and any use of Diodes Incorporated products in such safety-critical, life support devices or systems, notwithstanding any devices- or systems-related information or support that may be provided by Diodes Incorporated. Further, Customers must fully indemnify Diodes Incorporated and its representatives against any damages arising out of the use of Diodes Incorporated products in such safety-critical, life support devices or systems.

Copyright © 2014, Diodes Incorporated

www.diodes.com