



Atmel Digital Temperature Sensors Evaluation Kit

Atmel AT30TK175 Starter Kit Hardware User Guide

Features

- Four digital temperature sensor devices:
 - Atmel® AT30TSE002B
 - Atmel AT30TS75
 - Atmel AT30TS750
 - Atmel AT30TSE758
- Four event LEDs
- Four alarm status LEDs:
 - Critical, high, low, and normal
- Software switchable V_{CC} : 3.3V, 5.0V, and OFF
- Power LED

Contents

- One Atmel AT30TK175 adapter board
- One Atmel AT88Microbase AVR® base module
- 6-inch USB cable
- 18-inch extension cable

Introduction

This starter kit utilizes the Atmel AT30TK175 adapter board to allow users to experiment and develop with the Atmel AT30TSE002B, AT30TS75, AT30TS750, and AT30TSE758 digital temperature sensors.

The AT30TK175 daughterboard interfaces with the Atmel AT88Microbase board (included in the kit) to provide communication to a PC via a USB interface, allowing designers to learn and experiment with the temperature sensor demonstration utility. In addition, this kit supports a modular approach, enabling the AT30TK175 daughterboard to connect directly to an Atmel STK® series AVR development platform to easily add temperature monitoring capabilities to applications.

Figure 1. Atmel AT30TK175 adapter board

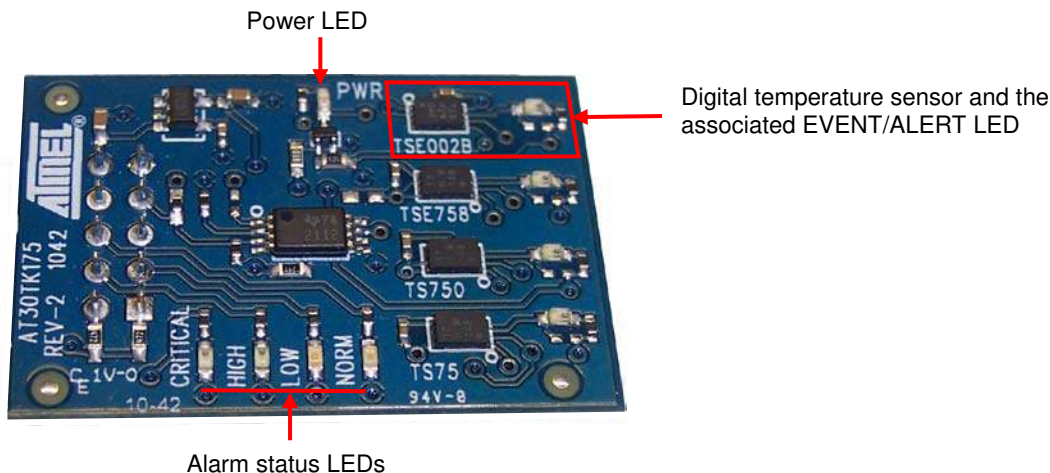



1. Atmel AT30TK175STK Starter Kit

The AT30TK175 is sold with the AT88Microbase to form the Atmel AT30TK175STK starter kit. For additional information on the AT88Microbase, see the “Atmel AT88Microbase Hardware User Guide.”

Figure 1-1. The Atmel AT30TK175 daughterboard with the Atmel AT88Microbase module

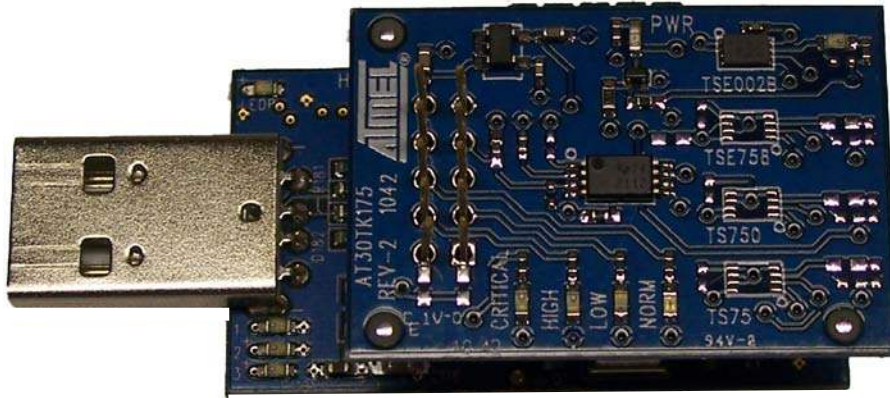

2. Board Configuration

Table 2-1. Seven-bit device address

Device	Atmel AT30TSE002B	Atmel AT30TS75	Atmel AT30TS750	Atmel AT30TSE758
Temperature sensor address	0x1B	0x48	0x49	0x4A
Serial EEPROM address	0x53	-	-	0x52

2.2. 10-pin Interface Header

Table 2-1. I²C pins: SCL, SD

Pins	10	9	8	7	6	5	4	3	2	1
Signal	VCC	GND	CRIT LED	VCC SEL	NORM LED	VCC EN	HIGH LED	LOW LED	SDA	SCL

Figure 2-2. 10-pin interface header orientation

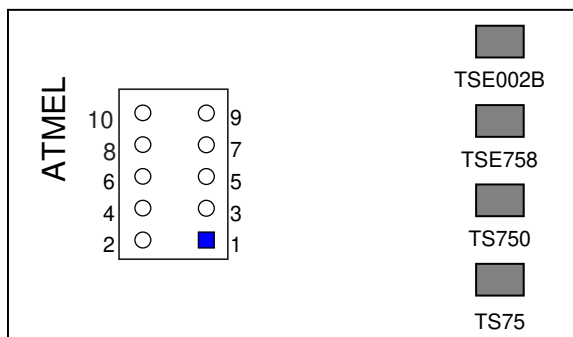

Note: VCC_SEL and VCC_EN are board-level options that allow users to set the board V_{CC} to 3.3V or 5.0V and disable V_{CC} with VCC_EN. These options are provided to allow the temperature sensor to be evaluated with both V_{CC} operating voltages and to evaluate the nonvolatile registers (see Section 2.3).

2.3. Alarm Status LEDs

Table 2-1. Alarm status LEDs

LED	Critical	High	Low	Normal
Color	Red	Red	Yellow	Green
Active state	High	High	High	High

2.4. V_{CC} Enable and Select Pins

Table 2-1. V_{CC} enable and select pins

Control	High	Low	State
VCC_EN	X		ON (Default)
VCC_EN		X	OFF
VCC_SEL	X		3.3V (Default)
VCC_SEL		X	5.0V



3. References and Further Information

Schematics, Gerber files, bill of materials (BOM), and development and demonstration software are conveniently downloadable from the Atmel website.

4. EVALUATION BOARD/KIT IMPORTANT NOTICE

This evaluation board/kit is intended for **ENGINEERING, DEVELOPMENT, DEMONSTRATION** or **EVALUATION PURPOSE ONLY**. It is not a finished product and may not (yet) comply with some or any technical or legal requirements that are applicable to finished products, including, without limitations, directives regarding electromagnetic compatibility, recycling (WEEE), FCC, CE or UL (except as may be otherwise noted on the board/kit). Atmel® supplied this board/kit "AS IS," without any warranties, with all faults, at the buyer's and further users' sole risk. The user assumes all responsibility and liability for proper and safe handling of goods. Further, the user indemnifies Atmel from claims arising from the handling or use of goods. Due to open construction of the product, it is the user's responsibility to take any and all appropriate precautions with regard to electrostatic discharge and any other technical or legal concerns.

EXCEPT TO THE EXTENT OF INDEMNITY SET FORTH ABOVE, NEITHER USER NOR ATMEL SHALL BE LIABLE TO EACH OTHER FOR ANY INDIRECT, SPECIAL, INCIDENTAL, OR CONSEQUENTIAL DAMAGES.

No license is granted under any patent right or other intellectual property right of Atmel covering or relating to any machine, process, or combination in which such Atmel product or services might be or are used.

Mailing Address: Atmel Corporation
 2325 Orchard Parkway
 San Jose, CA 95131

**Atmel Corporation**

2325 Orchard Parkway
San Jose, CA 95131
USA

Tel: (+1)(408) 441-0311

Fax: (+1)(408) 487-2600

www.atmel.com

Atmel Asia Limited

Unit 01-5 & 16, 19F
BEA Tower, Millennium City 5
418 Kwun Tong Road
Kwun Tong, Kowloon
HONG KONG

Tel: (+852) 2245-6100

Fax: (+852) 2722-1369

Atmel Munich GmbH

Business Campus
Parkring 4
D-85748 Garching b. Munich
GERMANY

Tel: (+49) 89-31970-0

Fax: (+49) 89-3194621

Atmel Japan

9F, Tonetsu Shinkawa Bldg.
1-24-8 Shinkawa
Chuo-ku, Tokyo 104-0033
JAPAN

Tel: (+81)(3) 3523-3551

Fax: (+81)(3) 3523-7581

© 2011 Atmel Corporation. All rights reserved. / Rev.: 8745A-DTS-5/11

Atmel®, logo and combinations thereof, and others are registered trademarks or trademarks of Atmel Corporation or its subsidiaries. Other terms and product names may be trademarks of others.

Disclaimer: The information in this document is provided in connection with Atmel products. No license, express or implied, by estoppel or otherwise, to any intellectual property right is granted by this document or in connection with the sale of Atmel products. EXCEPT AS SET FORTH IN THE ATMEL TERMS AND CONDITIONS OF SALES LOCATED ON THE ATMEL WEBSITE, ATMEL ASSUMES NO LIABILITY WHATSOEVER AND DISCLAIMS ANY EXPRESS, IMPLIED OR STATUTORY WARRANTY RELATING TO ITS PRODUCTS INCLUDING, BUT NOT LIMITED TO, THE IMPLIED WARRANTY OF MERCHANTABILITY, FITNESS FOR A PARTICULAR PURPOSE, OR NON-INFRINGEMENT. IN NO EVENT SHALL ATMEL BE LIABLE FOR ANY DIRECT, INDIRECT, CONSEQUENTIAL, PUNITIVE, SPECIAL OR INCIDENTAL DAMAGES (INCLUDING, WITHOUT LIMITATION, DAMAGES FOR LOSS AND PROFITS, BUSINESS INTERRUPTION, OR LOSS OF INFORMATION) ARISING OUT OF THE USE OR INABILITY TO USE THIS DOCUMENT, EVEN IF ATMEL HAS BEEN ADVISED OF THE POSSIBILITY OF SUCH DAMAGES. Atmel makes no representations or warranties with respect to the accuracy or completeness of the contents of this document and reserves the right to make changes to specifications and products descriptions at any time without notice. Atmel does not make any commitment to update the information contained herein. Unless specifically provided otherwise, Atmel products are not suitable for, and shall not be used in, automotive applications. Atmel products are not intended, authorized, or warranted for use as components in applications intended to support or sustain life.