

bq24150/150A/151/151A/152 YFF EVM (HPA256)

Contents

1	Introduction	1
	1.1 EVM Features	1
	1.2 General Description	2
	1.3 I/O Description	2
	1.4 Control and Key Parameters Setting	2
	1.5 Recommended Operating Conditions	2
2	Test Summary	3
	2.1 Definitions	3
	2.2 Equipment	3
	2.3 Equipment Setup	4
	2.4 Procedure	5
3	PCB Layout Guideline	6
4	Bill of Materials, Board Layout and Schematics	8
	4.1 Bill of Materials	8
	4.2 Board Layout	10
	4.3 Schematic	12

List of Figures

1	Connections of the HPA172 Kit	4
2	Original Test Setup for HPA256 (bq2415x EVM)	5
3	The Main Window of the bq2415x Evaluation Software (For bq24150/150A/151/151A/152).....	5
4	Test setup for HPA256	6
5	Top Layer	10
6	Bottom Layer	10
7	Top Assembly	11
8	Top Silk	11

List of Tables

1	Factory Jumper Settings	4
---	-------------------------------	---

1 Introduction

1.1 EVM Features

- Evaluation Module For BQ24150/150A/151/151A/152 in chip-scale (YFF) package
- High Efficiency Fully Integrated NMOS-NMOS Synchronous Buck Charger With 3MHz Frequency
- Integrated Power FETs for Up To 1.25-A Charge Rate
- Programmable Battery Voltage, Charge Current, and Input Current via I²C Interface
- Input Operating Range 4 V–6 V
- Boost Mode Operation for USB OTG
- LED Indication for Status Signals

- Test Points for Key Signals Available for Testing Purpose. Easy Probe Hook-up
- Jumpers Available. Easy to Change Connections.

1.2 General Description

The BQ24150/150A/151/151A/152 evaluation module is a complete charger module for evaluating compact, flexible, high-efficiency, USB-friendly switch-mode charge management solution for single-cell Li-ion and Li-polymer batteries used in a wide range of portable applications.

The BQ24150/150A/151/151A/152 integrates a synchronous PWM controller, power MOSFETs, input current sensing, high-accuracy current and voltage regulation, and charge termination, into a small WCSP package.

The charge parameters can be programmed through an I²C interface.

For details, see the appropriate data sheets ([SLUS824](#), [SLUS847](#), [SLUSA27](#), and [SLUS931](#)).

1.3 I/O Description

Jack	Description
J1-DC+	AC adapter or USB, positive output
J1-DC-	AC adapter or USB, negative output
J2-BAT-	Battery negative terminal, connect to DC-
J2-AUXPWR/CD	Connect to AUXPWR pin or CD pin
J2-BAT+	Charger positive output, connect to CSOUT pin
J3-SCL	I ² C clock, connect to SCL pin
J3-SDA	I ² C data, connect to SDA pin
J3-DC-	AC adapter or USB, negative output
J4-STAT	Status output, can be connected to STAT pin by JMP1 set to EXT (2-3)
J4-OTG/SLRST	Connect to OTG/SLRST pin
J4-DC-	AC adapter or USB, negative output

1.4 Control and Key Parameters Setting

Jack	Description	Factory Setting
JMP1	LED 1-2: Connect STAT pin to LED on EVM EXT 2-3: Connect STAT pin to J4-1	Jumper On LED (1-2)
JMP2	HI 1-2: OTG or SLRST high (input or battery voltage) LO 2-3: OTG or SLRST low (ground)	See Table 1
JMP3	J2-BAT+ connect to J2-AUXPWR/CD	
JMP4	AUXPWR/CD pin connect to high or low or float	
JMP5	OTG/SLRST pin 10k resistor to ground or float	Jumper ON

1.5 Recommended Operating Conditions

		Min	Typ	Max	Unit	Notes
Supply voltage, V _{IN}	Input voltage from ac adapter input	4	5	6	V	
Battery voltage, V _{BAT}	Voltage applied at VBAT terminal of J8	0	3-4.2	4.44	V	
Supply current, I _{AC}	Maximum input current from ac adapter input	0	0.1-0.5	1.5	A	
Charge current, I _{chrg}	Battery charge current	0.55	0.7	1.25	A	
Operating junction temperature range, T _J		0		125	°C	

2 Test Summary

2.1 Definitions

This procedure details how to configure the HPA256 evaluation board. On the test procedure the following naming conventions are followed. Refer to the HPA256 schematic for details.

VXXX :	External voltage supply name (VADP, VBT, VSBT)
LOADW:	External load name (LOADR, LOADI)
V(TPyyy):	Voltage at internal test point TPyyy. For example, V(TP12) means the voltage at TP12.
V(Jxx):	Voltage at jack terminal Jxx
V(TP(XXX)):	Voltage at test point "XXX". For example, V(ACDET) means the voltage at the test point which is marked as "ACDET".
V(XXX, YYY):	Voltage across point XXX and YYY.
I(JXX(YYY)):	Current going out from the YYY terminal of jack XX.
Jxx(BBB):	Terminal or pin BBB of jack xx
Jxx ON :	Internal jumper Jxx terminals are shorted
Jxx OFF:	Internal jumper Jxx terminals are open
Jxx (-YY-)	ON: Internal jumper Jxx adjacent terminals marked as "YY" are shorted
Measure: → A,B	Check specified parameters A, B. If measured values are not within specified limits the unit under test has failed.
Observe → A,B	Observe if A, B occur. If they do not occur, the unit under test has failed.

Assembly drawings have location for jumpers, test points and individual components.

2.2 Equipment

2.2.1 POWER SUPPLIES

Power Supply #1 (PS#1): a power supply capable of supplying 5-V at 2-A is required.

2.2.2 LOAD #1

A 10V (or above), 2A (or above) electronic load that can operate at constant current mode.

2.2.3 LOAD #2

A HP 6060B 3-60V/0–60A, 300W system DC electronic load.
Or: equivalent

2.2.4 METERS

Four Fluke 75, (equivalent or better)
Or: Two equivalent voltage meters and two equivalent current meters. The current meters must be able to measure 2A current.

2.2.5 COMPUTER

A computer with at least one USB port and a USB cable. The bq2415x evaluation software must be properly installed.

2.2.6 HPA172 COMMUNICATION KIT

A HPA172 USB to I2C communication kit.

2.2.7 SOFTWARE

Unzip BQ2415xSetup.zip and double click on the “SETUP.EXE” file. Follow the installation steps.

2.3 Equipment Setup

- (A) Set the power supply #1 for 5V ± 100mV DC, 2.0 ± 0.1A current limit and then turn off supply.
- (B) Connect the output of power supply #1 in series with a current meter (multimeter) to J1 (DC+, DC-).
- (C) Connect a voltage meter across J1 (DC+, DC-).
- (D) Connect the Load #2 in series with a current meter (multimeter) to J2 (BAT+, BAT-). Make sure a voltage meter is connected across J2 (BAT+, BAT-). Turn on the Load #2. Use the constant voltage mode. Set the output voltage to 2.5V.
- (E) Turn off Load #2.
- (F) Connect J5 to HPA172 kit by 10-pin ribbon cable. Connect the USB port of the HPA172 kit to the USB port of the computer. The connections are shown in [Figure 1](#).

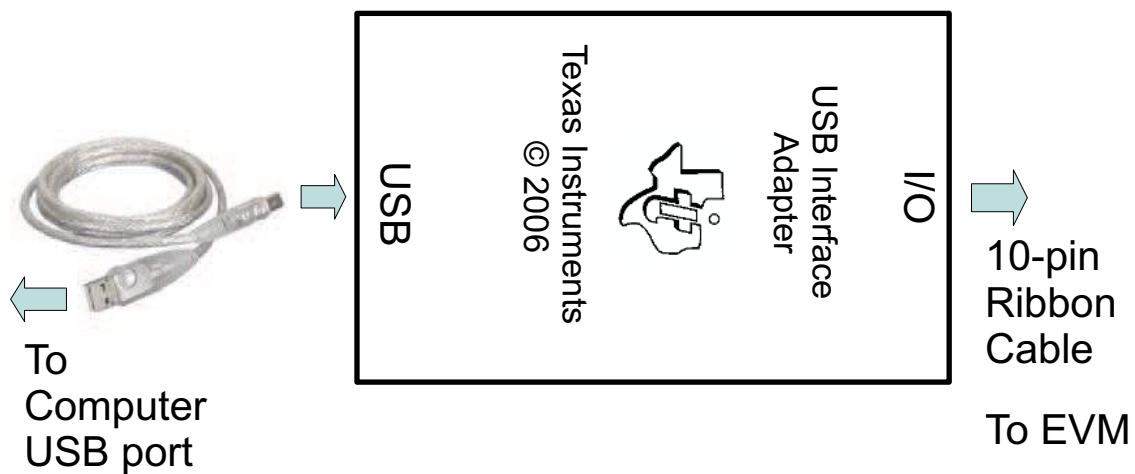

Figure 1. Connections of the HPA172 Kit

(G) Installed jumpers per [Table 1](#)

Table 1. Factory Jumper Settings

Spin	JMP1	JMP2	JMP3	JMP4	JMP5
HPA256-001 (bq24150)	(-LED-) ON	(-LO-) ON	ON	OFF	ON
HPA256-002 (bq24151)	(-LED-) ON	(-LO-) ON	ON	OFF	ON
HPA256-003 (bq24152)	(-LED-) ON	(-LO-) ON	ON	OFF	ON
HPA256-004 (bq24150A)	(-LED-) ON	(-LO-) ON	ON	OFF	ON
HPA256-005 (bq24151A)	(-LED-) ON	(-LO-) ON	ON	OFF	ON

(H) After the steps above, the test setup is shown in [Figure 2](#)

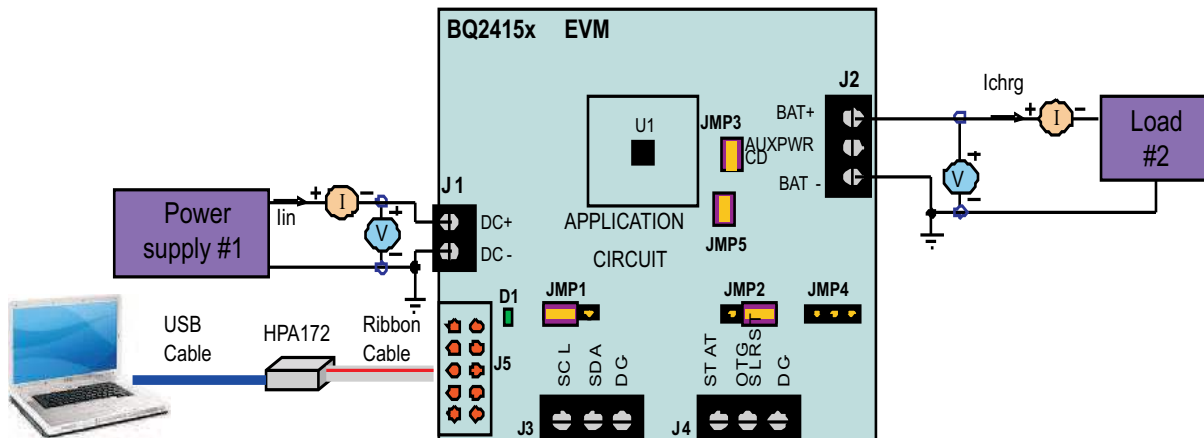

Figure 2. Original Test Setup for HPA256 (bq2415x EVM)

- (I) Turn on the computer.
- Open the bq2415x evaluation software. The main window of the software is shown in [Figure 3](#).

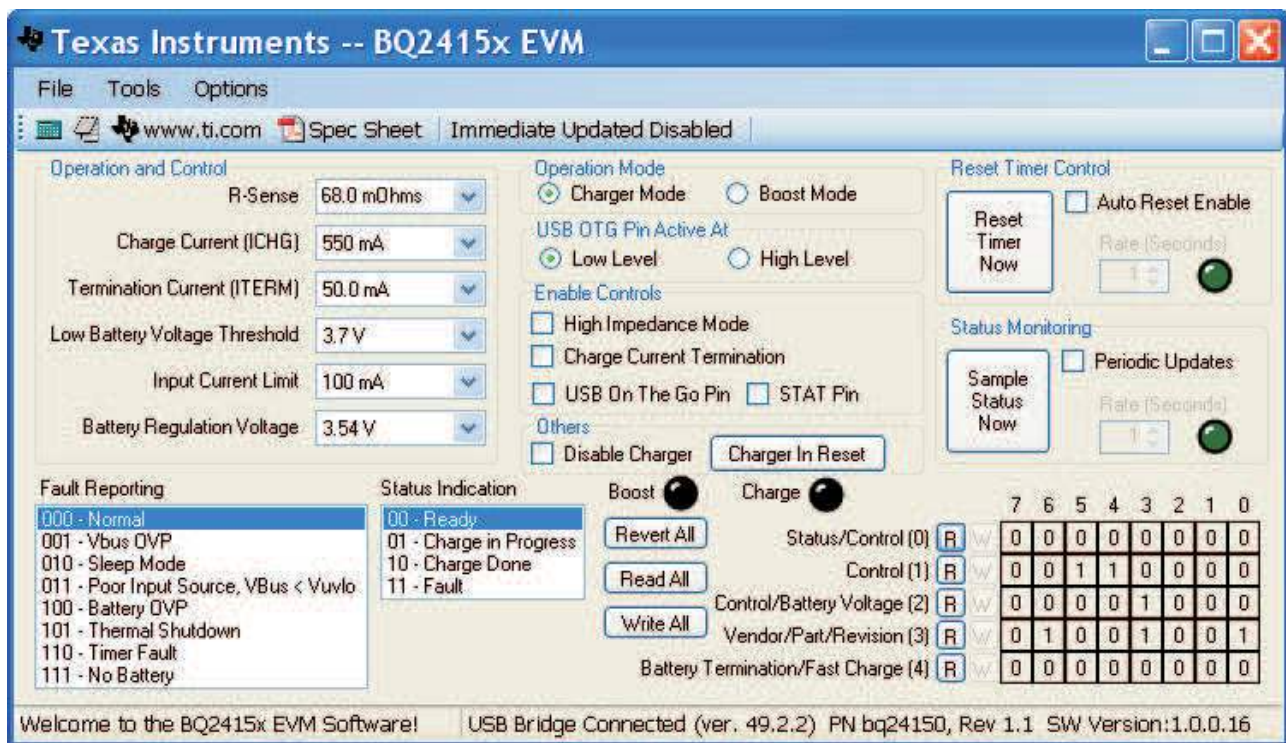

Figure 3. The Main Window of the bq2415x Evaluation Software (For bq24150/150A/151/151A/152)

2.4 Procedure

2.4.1 Charge Voltage and Current Regulation

1. Make sure the EQUIPMENT SETUP steps are followed. Turn on PS#1.
2. Software setup:
 - Click Immediate Update Disabled button. It changes to Immediate Update Enabled. Check Auto Reset Enable, set Rate to 5 seconds. Check Periodic Updates, set Rate to 1 second. Make sure

Operation Mode is Charger Mode. Uncheck Charge Current Termination. Check STAT Pin. Select Battery Regulation Voltage to 4.20V.

Measure → $V(J2(VBAT+, VBAT-)) = 4.2 \pm 100mV$

Observe → D1 is on.

3. Enable Load #2.

Measure → $V(J2(VBAT+, VBAT-)) = 2.5 \pm 100mV$

Measure → $I_{chrg} = 160mA \pm 40mA$

Measure → $I_{in} = 93mA \pm 5mA$

4. Select Charge Current to 950mA, select Input Current Limit to 500mA.

Measure → $I_{chrg} = 750mA \pm 100mA$

Measure → $I_{in} = 475mA \pm 25mA$

5. Check Disable Charger. Turn off PS#1, turn off Load #2 and disconnect

2.4.2 Boost Function

1. Adjust PS#1 output to 3.7V and disable the output. Connect the PS#1 in series with a current meter (multimeter) to J2 (BAT+, BAT-). Make sure a voltage meter is connected across J2 (BAT+, BAT-).
2. Set the Load #1 current to 200mA ± 20mA but disable the output. Connect the output of the Load #1 in series with a current meter (multimeter) to J1 (DC+, DC-). Make sure a voltage meter is connected across J1 (DC+, DC-). The setup is now like Figure 4 for HPA256.

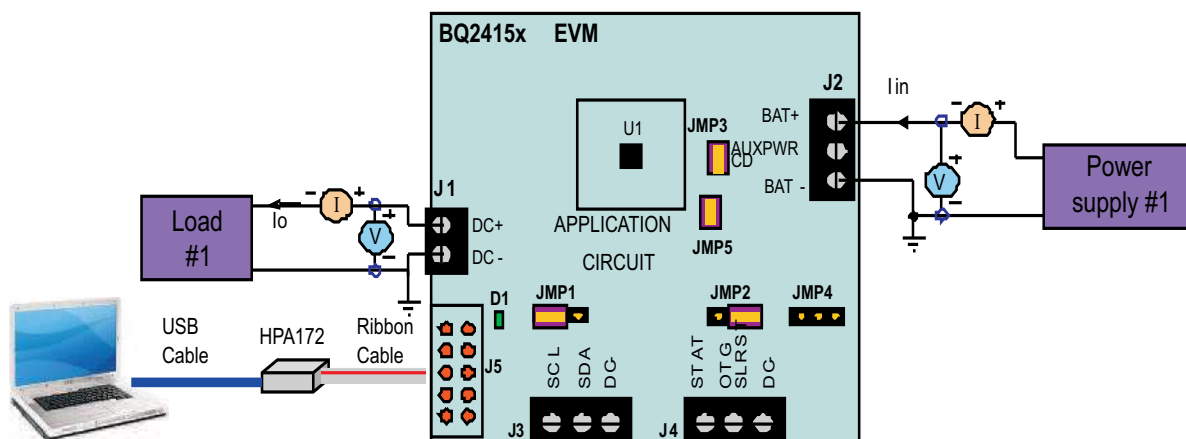

Figure 4. Test setup for HPA256

3. Turn on PS#1 output
4. Software setup: Change Operation Mode to Boost Mode.

Measure → $V(J1(DC+, DC-))=5V \pm 0.2V$

5. Enable Load #1.

Measure → $V(J1(DC+, DC-))=5V \pm 0.2V$

Measure → $I_{in} = 330mA \pm 40mA$

Measure → $I_o = 200mA \pm 20mA$

3 PCB Layout Guideline

1. To obtain optimal performance, the power input capacitors, connected from input to PGND, should be placed as close as possible to the IC.
2. The output inductor should be placed close to the IC and the output capacitor connected between the inductor and PGND of the IC. The intent is to minimize the current path loop area from the SW pin through the LC filter and back to the PGND pin. To prevent high frequency oscillation problems, proper layout to minimize high frequency current path loop is critical.
3. The sense resistor should be adjacent to the junction of the inductor and output capacitor. Route the sense leads connected across the RSNS back to the IC, close to each other (minimize loop area) or

- on top of each other on adjacent layers (do not route the sense leads through a high-current path).
4. Place all decoupling capacitor close to their respective IC pin and as close as to PGND (do not place components such that routing interrupts power stage currents). All small control signals should be routed away from the high current paths.
 5. The PCB should have a ground plane (return) connected directly to the return of all components through vias (two vias per capacitor for power-stage capacitors, two vias for the IC PGND, one via per capacitor for small-signal components). A star ground design approach is typically used to keep circuit block currents isolated (high-power/low-power small-signal) which reduces noise-coupling and ground-bounce issues. A single ground plane for this design gives good results. With this small layout and a single ground plane, there is no ground-bounce issue, and having the components segregated minimizes coupling between signals.
 6. The high-current charge paths into VBUS, PMID and from the SW pins must be sized appropriately for the maximum charge current in order to avoid voltage drops in these traces. The PGND pins should be connected to the ground plane to return current through the internal low-side FET.

4 Bill of Materials, Board Layout and Schematics

4.1 Bill of Materials

'24150-001	'24151-002	bq24152-003	'24150A-004	'24151A-005	RefDes	Value	Description	Size	Part Number	MFR
1	1	1	1	1	C1	1uF	Capacitor, Ceramic, X5R, 16V, +-10%	603	GRM188R61C105K	muRata
1	1	1	1	1	C2	4.7uF	Capacitor, Ceramic, X7R, 16V, +-10%	805	GRM21BR71C475K	muRata
2	2	2	2	2	C3, C9	10uF	Capacitor, Ceramic, X5R, 6.3V, +-20%	603	GRM188R60J106M	muRata
2	2	2	2	2	C4, C5	1uF	Capacitor, Ceramic, X5R, 10V, +-10%	402	GRM155R61A105K	muRata
1	1	1	1	1	C6	10nF	Capacitor, Ceramic, X5R, 16V, +-10%	402	GRM155R61C103K	muRata
2	2	2	2	2	C7, C8	0.1uF	Capacitor, Ceramic, X7R, 16V, +-10%	402	GRM155R71C104K	muRata
1	1	1	1	1	D1	Green	Diode, LED, Green, 2.1-V, 20-mA, 6-mcd	603	LTST-C190GKT	Liteon
1	1	1	1	1	D2	BAT54C	Diode, Dual Schottky, 200-mA, 30-V	SOT23	BAT54C	Vishay-Liteon
1	1	1	1	1	J1	ED1514/2DS	Terminal Block, 2-pin, 6-A, 3.5mm	0.27 x 0.25 inch	ED1514/2DS	OST
3	3	3	3	3	J2, J3, J4	ED1515/3DS	Terminal Block, 3-pin, 6-A, 3.5mm	0.41 x 0.25 inch	ED1515/3DS	OST
1	1	1	1	1	J5	2510-6002UB	Connector, Male Straight 2x5 pin, 100mil spacing, 4 Wall	0.338 x 0.788 inch	2510-6002UB	3M
3	3	3	3	3	JMP1, JMP2, JMP4	PTC03SAAN	Header, 3-pin, 100mil spacing, (36-pin strip)	0.100 inch x 3	PTC03SAAN	Sullins
2	2	2	2	2	JMP3, JMP5	PTC02SAAN	Header, 2-pin, 100mil spacing, (36-pin strip)	0.100 inch x 2	PTC02SAAN	Sullins
4	4	4	4	4		929950-00	Shorting jumpers, 2-pin, 100mil spacing,		929950-00	3M/ESD
1	1	1	1	1	L1	1.0uH	2.5mmx2mm, 1.0uH, +/-30%, 1.5A	0.11x0.09 inch	"LQM2HPN1R0MJ0 or MIPS2520D1R0 or MDT2520-CN1R0M or CP1008"	muRata or FDK or TOKO or Inter-Technical
1	1	1	1	1	R1	0.068	Resistor, Chip, 68mohm, 125mW, 5%	402	ERJ-2BWJR068X	Panasonic
1	1	1	1	1	R2	5.1k	Resistor, Chip, 5.1k-Ohms, 1/16-W, 5%	603	Std	Std

'24150-001	'24151-002	bq24152-003	'24150A-004	'24151A-005	RefDes	Value	Description	Size	Part Number	MFR
1	1	1	1	1	R3	10k	Resistor, Chip, 10k-Ohms, 1/16-W, 5%	603	Std	Std
1	1	1	1	1	R4	200	Resistor, Chip, 200-Ohms, 1/16-W, 5%	603	Std	Std
1	1	1	1	1	R5	200	Resistor, Chip, 200-Ohms, 1/16-W, 5%	603	Std	Std
1	0	0	0	0	U1	BQ24150YFF	IC, Battery Charger for Single-Cell Li-Ion and Li-Polymer Battery	WCSP	BQ24150YFF	TI
0	1	0	0	0	U1	BQ24151YFF	IC, Battery Charger for Single-Cell Li-Ion and Li-Polymer Battery	WCSP	BQ24151YFF	TI
0	0	1	0	0	U1	BQ24152YFF	IC, Battery Charger for Single-Cell Li-Ion and Li-Polymer Battery	WCSP	BQ24152YFF	TI
0	0	0	1	0	U1	BQ24150AYFF	IC, Battery Charger for Single-Cell Li-Ion and Li-Polymer Battery	WCSP	BQ24150AYFF	TI
0	0	0	0	1	U1	BQ24151AYFF	IC, Battery Charger for Single-Cell Li-Ion and Li-Polymer Battery	WCSP	BQ24151AYFF	TI
1	1	1	1	1	--	HPA256	PCB, 2.0 In x 2.0 In x 0.031 In		PCB	Any

4.2 Board Layout

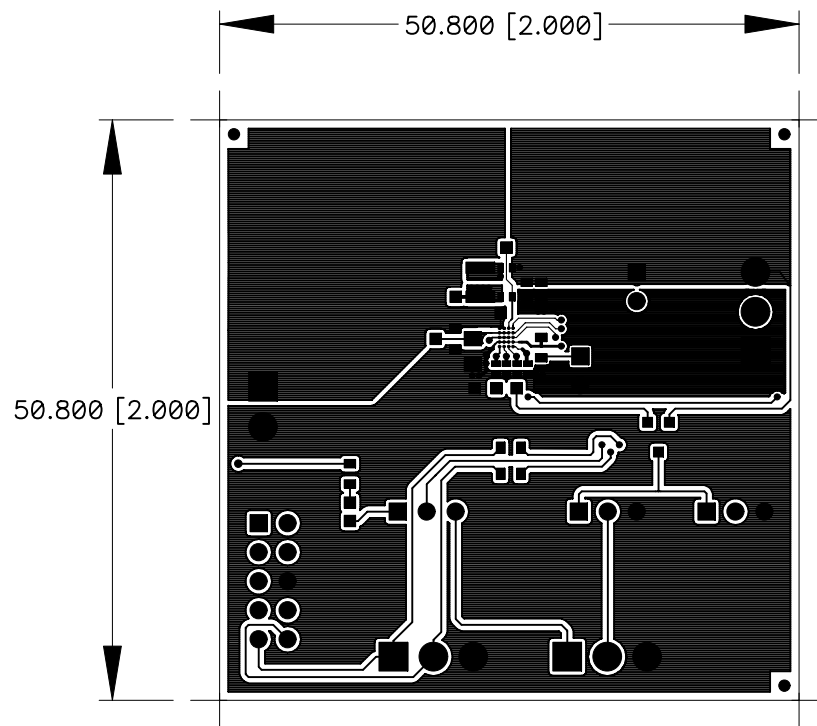

Figure 5. Top Layer

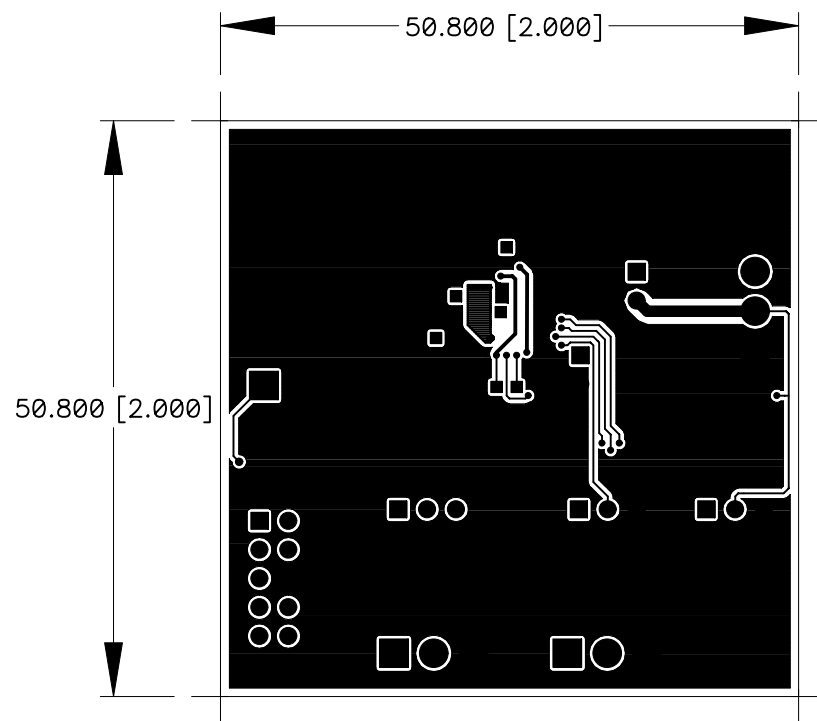

Figure 6. Bottom Layer

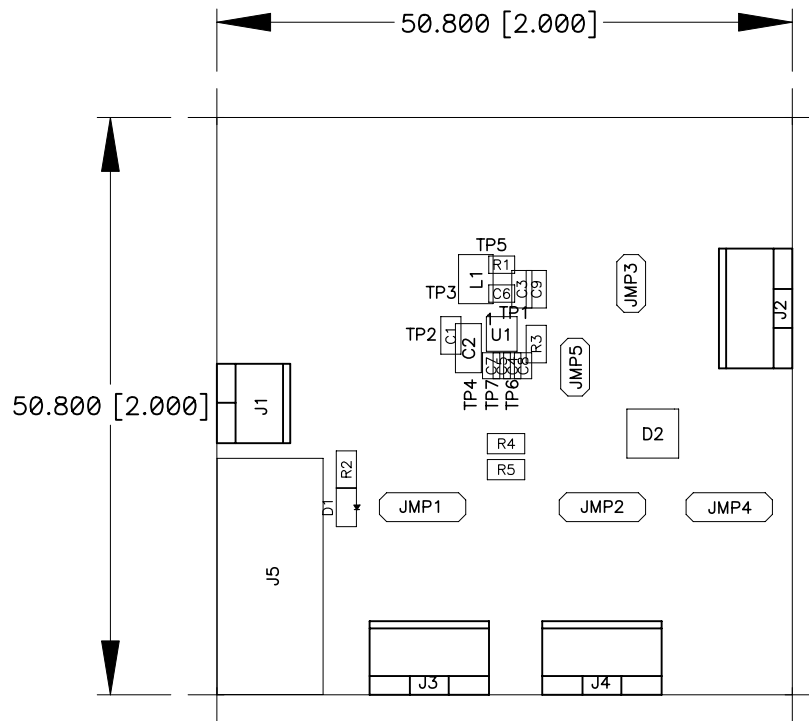

Figure 7. Top Assembly

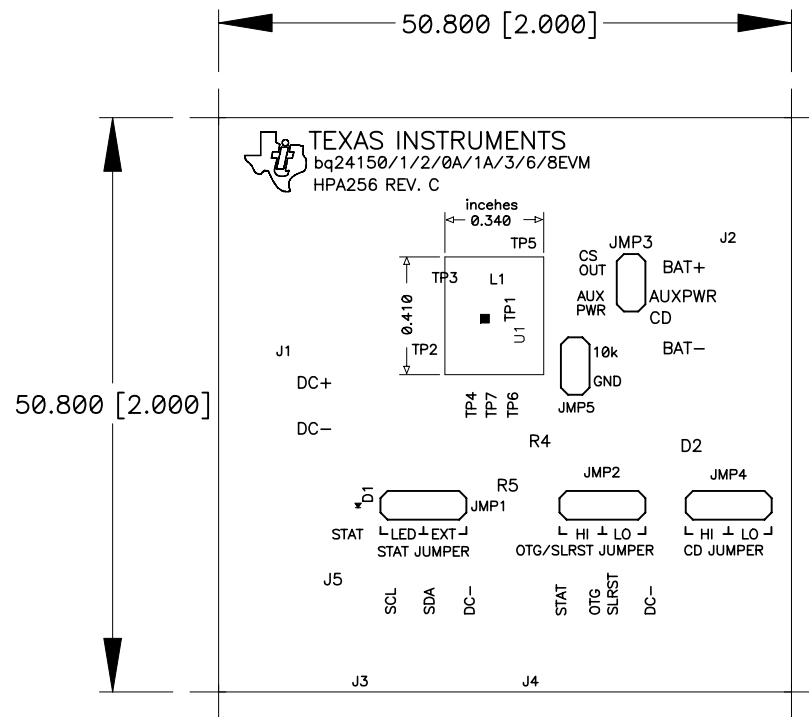
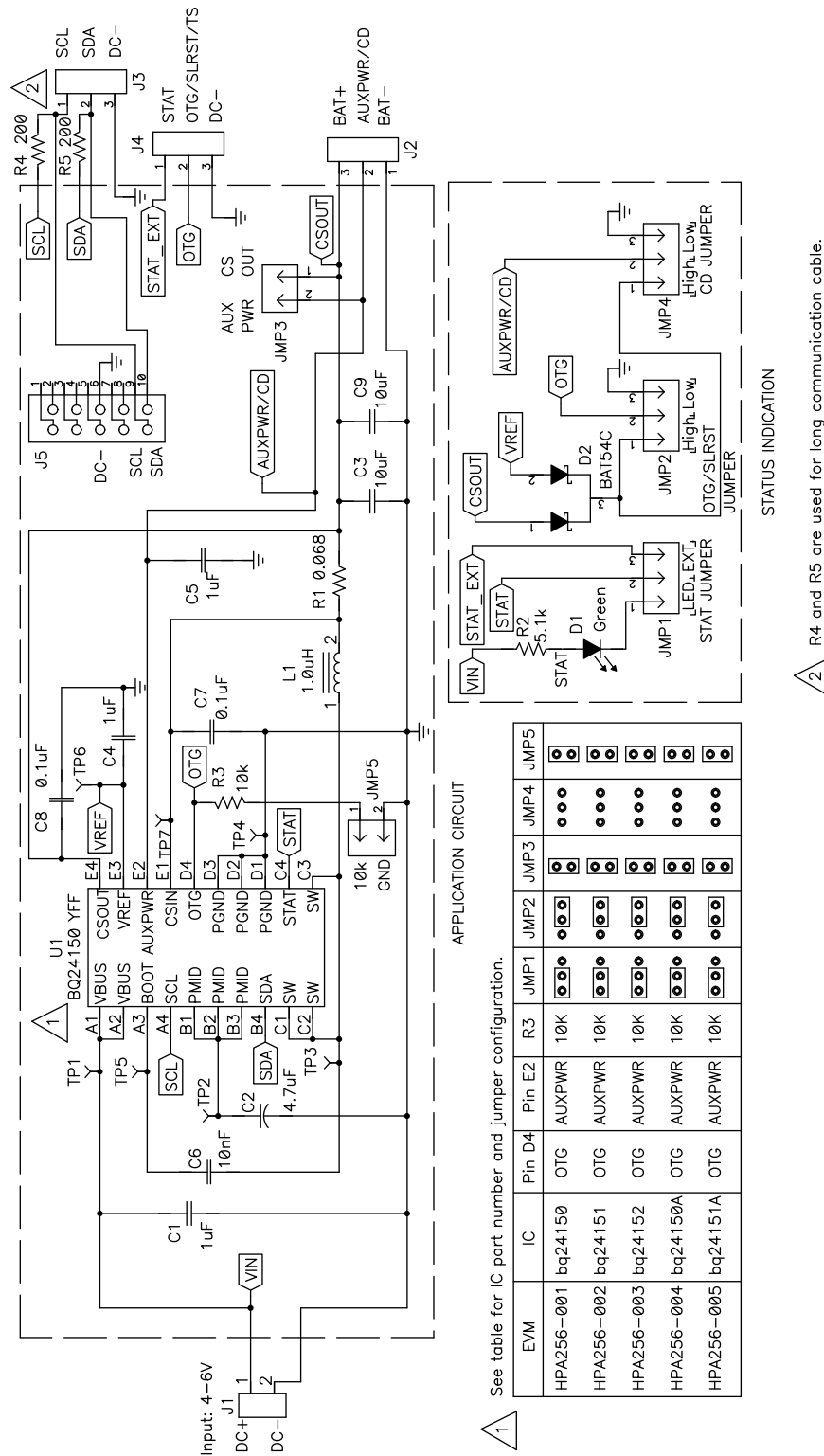

Figure 8. Top Silk

4.3 Schematic



APPLICATION CIRCUIT

See table for IC part number and jumper configuration.

EVM	IC	Pin D4	Pin E2	R3	JMP1	JMP2	JMP3	JMP4	JMP5
HPA256-001	bq24150	OTG	AUXPWR	10k	●●	●●	●●	●●	●●
HPA256-002	bq24151	OTG	AUXPWR	10k	●●	●●	●●	●●	●●
HPA256-003	bq24152	OTG	AUXPWR	10k	●●	●●	●●	●●	●●
HPA256-004	bq24150A	OTG	AUXPWR	10k	●●	●●	●●	●●	●●
HPA256-005	bq24151A	OTG	AUXPWR	10k	●●	●●	●●	●●	●●

STATUS INDICATION

△ R4 and R5 are used for long communication cable.

Evaluation Board/Kit Important Notice

Texas Instruments (TI) provides the enclosed product(s) under the following conditions:

This evaluation board/kit is intended for use for **ENGINEERING DEVELOPMENT, DEMONSTRATION, OR EVALUATION PURPOSES ONLY** and is not considered by TI to be a finished end-product fit for general consumer use. Persons handling the product(s) must have electronics training and observe good engineering practice standards. As such, the goods being provided are not intended to be complete in terms of required design-, marketing-, and/or manufacturing-related protective considerations, including product safety and environmental measures typically found in end products that incorporate such semiconductor components or circuit boards. This evaluation board/kit does not fall within the scope of the European Union directives regarding electromagnetic compatibility, restricted substances (RoHS), recycling (WEEE), FCC, CE or UL, and therefore may not meet the technical requirements of these directives or other related directives.

Should this evaluation board/kit not meet the specifications indicated in the User's Guide, the board/kit may be returned within 30 days from the date of delivery for a full refund. **THE FOREGOING WARRANTY IS THE EXCLUSIVE WARRANTY MADE BY SELLER TO BUYER AND IS IN LIEU OF ALL OTHER WARRANTIES, EXPRESSED, IMPLIED, OR STATUTORY, INCLUDING ANY WARRANTY OF MERCHANTABILITY OR FITNESS FOR ANY PARTICULAR PURPOSE.**

The user assumes all responsibility and liability for proper and safe handling of the goods. Further, the user indemnifies TI from all claims arising from the handling or use of the goods. Due to the open construction of the product, it is the user's responsibility to take any and all appropriate precautions with regard to electrostatic discharge.

EXCEPT TO THE EXTENT OF THE INDEMNITY SET FORTH ABOVE, NEITHER PARTY SHALL BE LIABLE TO THE OTHER FOR ANY INDIRECT, SPECIAL, INCIDENTAL, OR CONSEQUENTIAL DAMAGES.

TI currently deals with a variety of customers for products, and therefore our arrangement with the user **is not exclusive.**

TI assumes **no liability for applications assistance, customer product design, software performance, or infringement of patents or services described herein.**

Please read the User's Guide and, specifically, the Warnings and Restrictions notice in the User's Guide prior to handling the product. This notice contains important safety information about temperatures and voltages. For additional information on TI's environmental and/or safety programs, please contact the TI application engineer or visit www.ti.com/esh.

No license is granted under any patent right or other intellectual property right of TI covering or relating to any machine, process, or combination in which such TI products or services might be or are used.

FCC Warning

This evaluation board/kit is intended for use for **ENGINEERING DEVELOPMENT, DEMONSTRATION, OR EVALUATION PURPOSES ONLY** and is not considered by TI to be a finished end-product fit for general consumer use. It generates, uses, and can radiate radio frequency energy and has not been tested for compliance with the limits of computing devices pursuant to part 15 of FCC rules, which are designed to provide reasonable protection against radio frequency interference. Operation of this equipment in other environments may cause interference with radio communications, in which case the user at his own expense will be required to take whatever measures may be required to correct this interference.

EVM Warnings and Restrictions

It is important to operate this EVM within the input voltage range of 4 V to 6 V and the output voltage range of 0 V to 4.44 V .

Exceeding the specified input range may cause unexpected operation and/or irreversible damage to the EVM. If there are questions concerning the input range, please contact a TI field representative prior to connecting the input power.

Applying loads outside of the specified output range may result in unintended operation and/or possible permanent damage to the EVM. Please consult the EVM User's Guide prior to connecting any load to the EVM output. If there is uncertainty as to the load specification, please contact a TI field representative.

During normal operation, some circuit components may have case temperatures greater than 65°C. The EVM is designed to operate properly with certain components above 125°C as long as the input and output ranges are maintained. These components include but are not limited to linear regulators, switching transistors, pass transistors, and current sense resistors. These types of devices can be identified using the EVM schematic located in the EVM User's Guide. When placing measurement probes near these devices during operation, please be aware that these devices may be very warm to the touch.

Mailing Address: Texas Instruments, Post Office Box 655303, Dallas, Texas 75265
Copyright © 2011, Texas Instruments Incorporated

IMPORTANT NOTICE

Texas Instruments Incorporated and its subsidiaries (TI) reserve the right to make corrections, modifications, enhancements, improvements, and other changes to its products and services at any time and to discontinue any product or service without notice. Customers should obtain the latest relevant information before placing orders and should verify that such information is current and complete. All products are sold subject to TI's terms and conditions of sale supplied at the time of order acknowledgment.

TI warrants performance of its hardware products to the specifications applicable at the time of sale in accordance with TI's standard warranty. Testing and other quality control techniques are used to the extent TI deems necessary to support this warranty. Except where mandated by government requirements, testing of all parameters of each product is not necessarily performed.

TI assumes no liability for applications assistance or customer product design. Customers are responsible for their products and applications using TI components. To minimize the risks associated with customer products and applications, customers should provide adequate design and operating safeguards.

TI does not warrant or represent that any license, either express or implied, is granted under any TI patent right, copyright, mask work right, or other TI intellectual property right relating to any combination, machine, or process in which TI products or services are used. Information published by TI regarding third-party products or services does not constitute a license from TI to use such products or services or a warranty or endorsement thereof. Use of such information may require a license from a third party under the patents or other intellectual property of the third party, or a license from TI under the patents or other intellectual property of TI.

Reproduction of TI information in TI data books or data sheets is permissible only if reproduction is without alteration and is accompanied by all associated warranties, conditions, limitations, and notices. Reproduction of this information with alteration is an unfair and deceptive business practice. TI is not responsible or liable for such altered documentation. Information of third parties may be subject to additional restrictions.

Resale of TI products or services with statements different from or beyond the parameters stated by TI for that product or service voids all express and any implied warranties for the associated TI product or service and is an unfair and deceptive business practice. TI is not responsible or liable for any such statements.

TI products are not authorized for use in safety-critical applications (such as life support) where a failure of the TI product would reasonably be expected to cause severe personal injury or death, unless officers of the parties have executed an agreement specifically governing such use. Buyers represent that they have all necessary expertise in the safety and regulatory ramifications of their applications, and acknowledge and agree that they are solely responsible for all legal, regulatory and safety-related requirements concerning their products and any use of TI products in such safety-critical applications, notwithstanding any applications-related information or support that may be provided by TI. Further, Buyers must fully indemnify TI and its representatives against any damages arising out of the use of TI products in such safety-critical applications.

TI products are neither designed nor intended for use in military/aerospace applications or environments unless the TI products are specifically designated by TI as military-grade or "enhanced plastic." Only products designated by TI as military-grade meet military specifications. Buyers acknowledge and agree that any such use of TI products which TI has not designated as military-grade is solely at the Buyer's risk, and that they are solely responsible for compliance with all legal and regulatory requirements in connection with such use.

TI products are neither designed nor intended for use in automotive applications or environments unless the specific TI products are designated by TI as compliant with ISO/TS 16949 requirements. Buyers acknowledge and agree that, if they use any non-designated products in automotive applications, TI will not be responsible for any failure to meet such requirements.

Following are URLs where you can obtain information on other Texas Instruments products and application solutions:

Products

Audio	www.ti.com/audio
Amplifiers	amplifier.ti.com
Data Converters	dataconverter.ti.com
DLP® Products	www.dlp.com
DSP	dsp.ti.com
Clocks and Timers	www.ti.com/clocks
Interface	interface.ti.com
Logic	logic.ti.com
Power Mgmt	power.ti.com
Microcontrollers	microcontroller.ti.com
RFID	www.ti-rfid.com
RF/IF and ZigBee® Solutions	www.ti.com/lprf

Applications

Communications and Telecom	www.ti.com/communications
Computers and Peripherals	www.ti.com/computers
Consumer Electronics	www.ti.com/consumer-apps
Energy and Lighting	www.ti.com/energy
Industrial	www.ti.com/industrial
Medical	www.ti.com/medical
Security	www.ti.com/security
Space, Avionics and Defense	www.ti.com/space-avionics-defense
Transportation and Automotive	www.ti.com/automotive
Video and Imaging	www.ti.com/video
Wireless	www.ti.com/wireless-apps

TI E2E Community Home Page

e2e.ti.com

Mailing Address: Texas Instruments, Post Office Box 655303, Dallas, Texas 75265
Copyright © 2011, Texas Instruments Incorporated