

PART NUMBER	REVISION	DESCRIPTION	FEED TYPE
2150256-2	C	FINE CRIMP HEIGHT ADJUST	PNEUMATIC
7-2150256-2	C	PNEUMATIC AND CRIMP TOOLING KIT	PNEUMATIC
7-2150256-7	A	CRIMP TOOLING KIT	-

ATLANTIC VERSION TERMINATOR INTERFACE ADAPTER

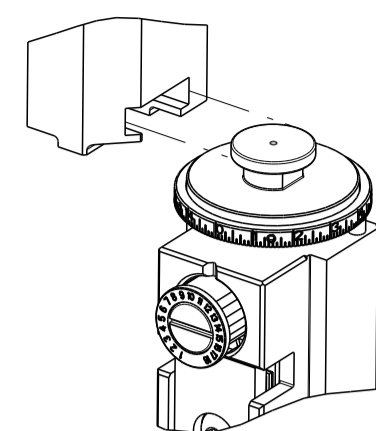

APPLICATOR DATA		
CRIMP	SIZE	TYPE
WIRE	3.05 mm [.120]	F
INSUL	4.06 mm [.160]	F
APPLICATOR INSTRUCTIONS 408-35043		

TERMINAL DATA: METALLON TERMINAL TE CRIMP SPECIFICATION

TERMINAL NAME: TERMINAL RING

WIRE STRIP LENGTH	INSULATION DIAMETER RANGE
.185-.200 IN [4.70-5.08 mm]	∅.060-.113 IN [1.52-2.87 mm]

TERMINAL APPLICATION SPECIFICATION	114-2065

TERMINALS APPLIED

TE TERMINAL	METALLON TERMINAL	TE TERMINAL	LEAR TERMINAL
2113265-1	139-6914	2113265-2	101614-K02
2113265-3	139-6913	2113265-4	101617-K02
2113265-5	101614-K01	2113265-6	101614-K17
2113265-7	101620-K01	2113265-8	101620-K02
2113265-9	101620-K17	1-2113265-0	101617-K01
1-2113265-1	101617-K17	1-2113265-2	101619-K01
1-2113265-3	101619-K02	1-2113265-4	101619-K17
1-2113265-5	101625-K01	1-2113265-6	101625-K02
1-2113265-7	101625-K17	1-2113265-8	101626-K01
1-2113265-9	101626-K02	2-2113265-0	101626-K17

WIRE SIZE	CRIMP HEIGHT mm [INCH]	CRIMP HEIGHT REFERENCE SETTING
18 AWG	1.91+/-0.05 [0.075+/-0.002]	2.6
20 AWG	1.80+/-0.05 [0.071+/-0.002]	4.0

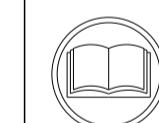

- 1. RECOMMENDED SPARE PARTS
- 2. REFER TO SUPPLIED INSTRUCTION SHEET FOR CLEANING, LUBRICATION AND STORAGE OF APPLICATOR.
- 3. APPLY PART NUMBER 2-23419-6 LOCTITE TO THREADS OF ITEM 242. APPLY PART NUMBER 1-23419-5 LOCTITE TO THREADS OF ITEM 50.
- 4. CRIMP HEIGHT REFERENCE SETTING WAS THE SETTING USED WHEN THE APPLICATOR WAS QUALIFIED AT THE FACTORY. ADJUSTMENT MAY BE NECESSARY WHEN RUNNING APPLICATOR IN THE FIELD.
- 5. TERMINAL PITCH NOT COMPATIBLE WITH MECHANICAL FEED.
- 6. UNLESS SPECIFIED OTHERWISE TORQUE VALUES SHALL BE USED PER DOCUMENT, 101-35000.

***WARNING**
ON INSTALLATION, SET WIRE DISC TO CRIMP HEIGHT REFERENCE SETTING FOR LARGEST WIRE SIZE. CRIMP HEIGHT REFERENCE SETTINGS GREATER THAN THE VALUE SHOWN MAY CAUSE DAMAGE TO THE CRIMP TOOLING. REFER TO THE INSTRUCTION SHEET FOR PROPER SETUP AND ADJUSTMENTS.

LOC	DIST	REVISIONS					
A	66	P	LTN	DESCRIPTION	DATE	OWN	APVD
		A2		ECR-18-015532	29SEP2018	FZ	KZ
		B		ECR-18-017906	14NOV2018	TB	CT
		C		ECR-21-003300	17MAR2021	FJ	TE
		C1		ECR-23-178996	21JUN2023	FZ	JAH

-	1	1	2119641-1	FEED CAM, AIR FEED	248	
-	1	1	2119082-9	CAM, SNAIL, INSULATION ADJUSTMENT	244	
-	1	1	2079764-1	WASHER, WAVE SPRING, CREST-TO-CREST	243	
-	1	1	2119083-1	RETAINER, INSULATION DIAL	242	
-	1	1	2844940-3	AIR FEED MODULE	238	
-	1	1	1-18028-0	WASHER, FLAT, REG M8	192	
-	1	1	6-993111-6	PIN, SLOTTED SPRING 3.0 X 14.0	177	
-	1	1	8-22280-7	SPRING, COMPRESSION	176	
-	1	1	1752353-2	GUIDE PIN,HOLDDOWN	175	
-	1	1	1901680-2	GUIDE PIN,HOLDDOWN	174	
-	REF	REF	994970-2	COUNTER, MAGNETIC	164	
-	1	1	455888-5	SPACER, CRIMPER	82	
-	1	1	2119791-9	DEPRESSOR, WIRE	73	
-	1	1	1803607-4	DOCUMENTATION PACKAGE	71	
-	2	2	2-18032-2	SCR, SET, FLT PNT, M3 X 10.0	70	
-	1	1	2119740-1	TAG, IDENTIFICATION	67	
-	2	2	2168078-1	SCREW, DRIVE, RH, RoHS, 2 x .188	66	
-	1	1	1901681-5	HOLDDOWN, TERMINAL	65	
-	1	1	2168083-2	SCR, SKT HD CAP, RoHS, M4 X 8.0	60	
-	1	1	5-18022-5	SCR, HEX HD CAP, M4 X 6.0	59	
-	4	4	2168400-4	SHCS, LOW HEAD, RoHS, M4 X 8	57	
-	2	2	2-2168083-5	SCR, SKT HD CAP, RoHS, M4 X 14	56	
-	2	2	5018030-1	NUT, HEX, REG, RoHS, M3	54	
-	2	2	986965-8	NUT, LOCK, HEX, TORQUE (M4)	53	
-	1	1	1-5018030-0	NUT, HEX, REG, RoHS, M3.5	52	
-	1	1	2063961-1	FEED FINGER	51	
-	1	1	1752354-2	STANDOFF,HOLD-DOWN	50	
-	1	1	18023-9	SCR, SKT HD CAP M4 X 6.0	49	
-	1	1	2119655-5	APPLICATOR BASIC ASSEMBLY, EF	46	
-	1	1	1803517-1	RAM ASSEMBLY, EF ATLANTIC	44	
-	1	1	1803602-1	SCR, BHSC, RoHS (M8 X 25)	41	
-	8	8	1-18028-2	WASHER, FLAT, REG M4	33	
-	2	2	2168083-9	SCR, SKT HD CAP, RoHS, M4 X 20	31	
-	2	2	2168083-2	SCR, SKT HD CAP, RoHS, M4 X 8.0	29	
-	1	1	240639-1	STRIPPER (MACHINING)	27	
-	2	2	1-2168083-5	SCR, SKT HD CAP, RoHS, M4 X 30	25	
-	1	1	1752371-5	PLATE, STRIP GUIDE	24	
-	2	2	2-22281-3	SPRING, COMPRESSION	22	
-	1	1	1803292-1	DRAG	20	
-	1	1	1901696-3	STRIP GUIDE, REAR	19	
-	1	1	1901695-3	STRIP GUIDE, FRONT	18	
-	4	4	1-2079383-1	SCR, BHSC, RoHS (M6 X 12)	17	
-	1	1	1752360-1	SPACER,HOLD-DOWN	13	
-	1	1	240644-1	PLATE, REAR SHEAR	11	
-	-	-	-	-	10	
-	1	1	690482-1	PLATE, FRONT SHEAR	9	
-	1	2	1	1803060-1	ANVIL, COMBINATION, END FEED	8
-	1	1	1	690474-2	BLADE, SLUG	7
-	1	1	1	7-240641-2	SPACER	5
-	1	1	1	238011-2	BLOCK, CRIMPER SPACER	4
-	1	2	1	2-1633961-3	CRIMPER, INSULATION F PREMIUM	3
-	1	1	1	455888-3	SPACER, CRIMPER	2
-	1	2	1	456409-3	CRIMPER, WIRE .120 "F" PREMIUM	1
-	77	72	2	PART NO	DESCRIPTION	ITEM NO

ATLANTIC VERSION
Shown on sheets 1 of 4 & 2 of 4
(Pacific version shown on sheets 3 of 4 & 4 of 4)

DIMENSIONS:		TOLERANCES UNLESS OTHERWISE SPECIFIED:		OWN: STAKEM 03MAY2012	TE Connectivity Harrisburg, PA 17105-3608
mm		0 PLC ± 1 PLC ± 2 PLC ± 3 PLC ± 4 PLC ± ANGLES ±		CHK: G. BAILEY 03MAY2012	
MATERIAL:		FINISH:		APVD: T. ELBIN 03MAY2012	NAME: Ocean End Feed Applicator
				SIZE: A1	CAGE CODE: 00779
				WEIGHT:	DRAWING NO: C=2150256
				Customer Accessible Production Drawing	
				SCALE: 1:1	SHEET 1 OF 4
				REV: C1	

LOC	DIST	REV	DATE	BY	APPV
A	66				

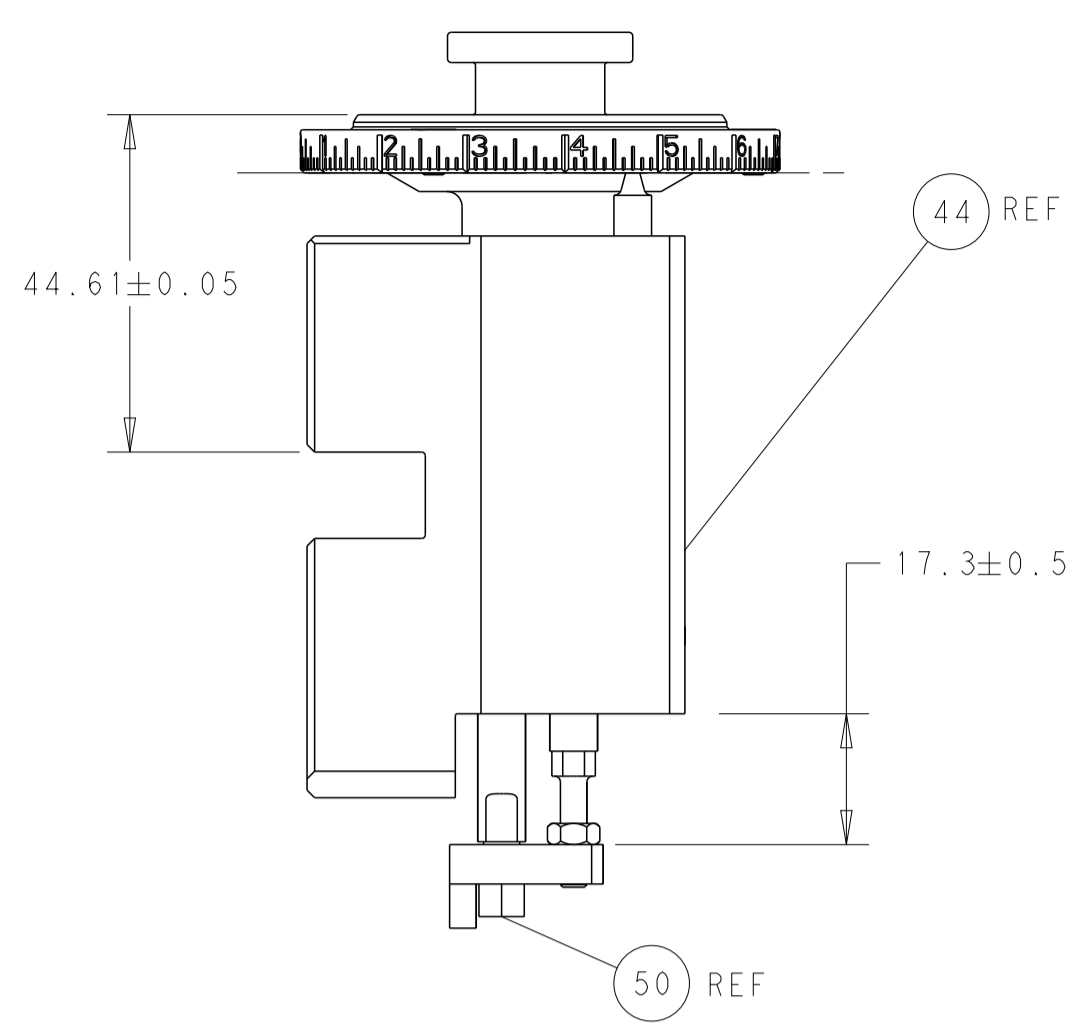

RAM AND HOLDDOWN SET-UP

FEED TYPE

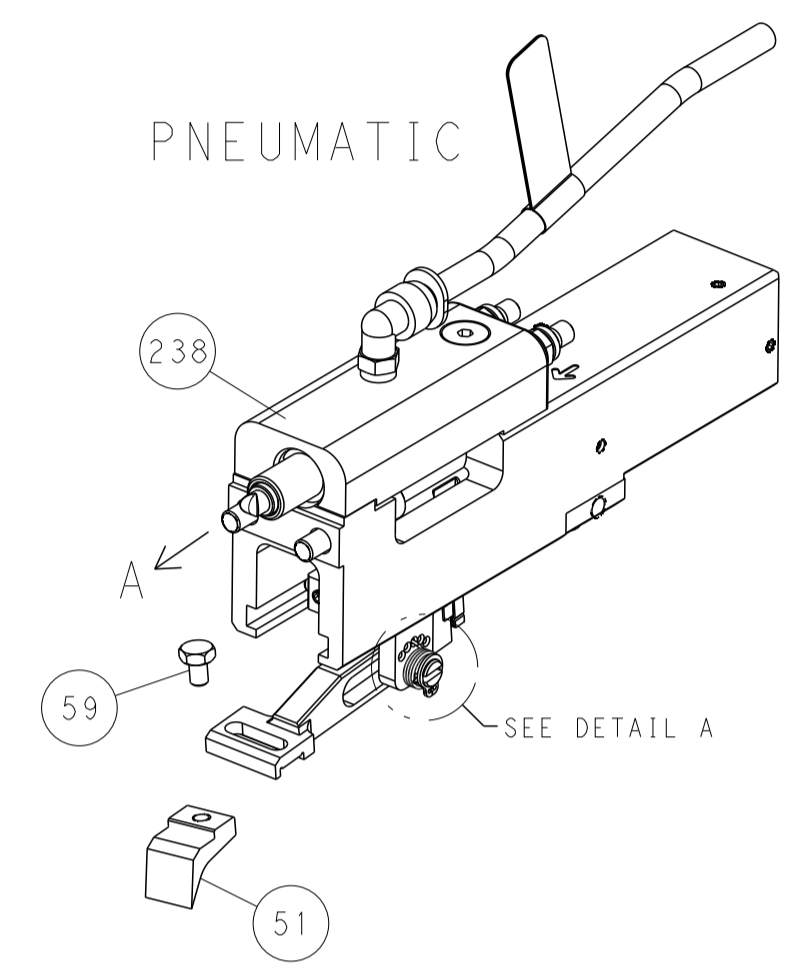

FEED SPRING SETTING POSITION

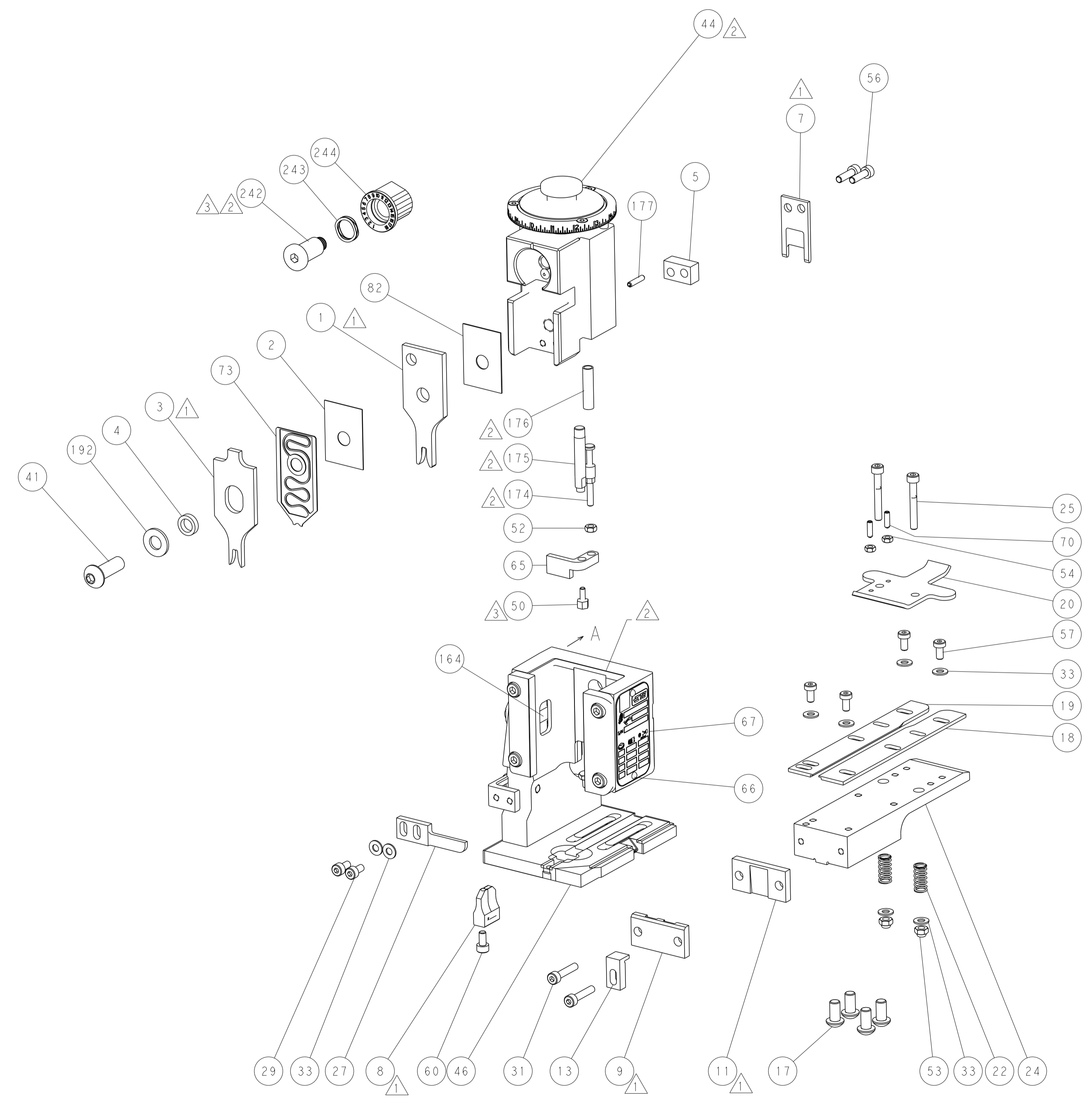
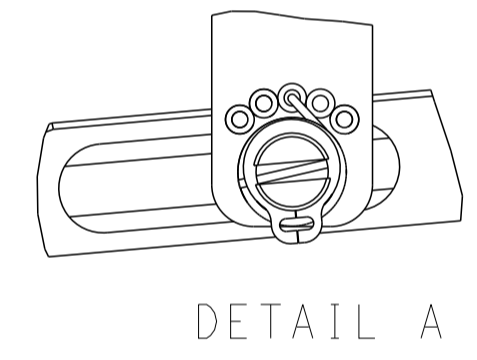

CAM POSITION

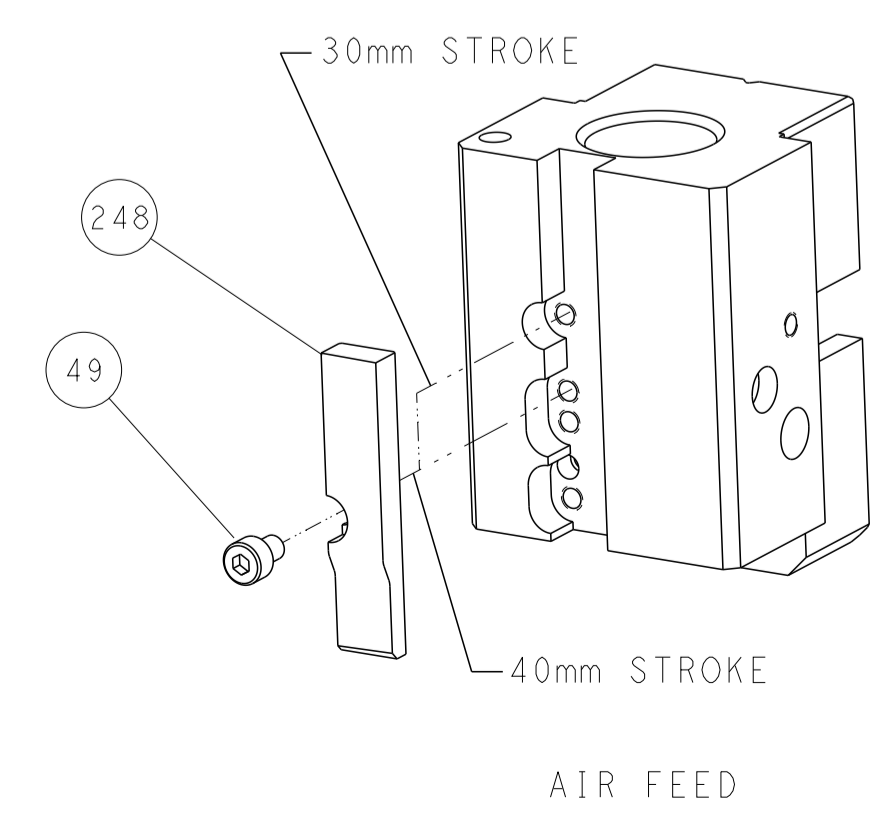

ATLANTIC VERSION
 Shown on sheets 1 of 4 & 2 of 4
 (Pacific version shown on sheets 3 of 4 & 4 of 4)

<small>THIS DRAWING IS UNPUBLISHED. RELEASED FOR PUBLICATION BY TYCO ELECTRONICS CORPORATION. ALL RIGHTS RESERVED.</small>		DWN: K. STAKEM 03MAY2012 CHK: G. BAILEY 03MAY2012 APVD: T. ELBIN 03MAY2012	TE Connectivity Harrisburg, PA 17105-3608
DIMENSIONS: mm TOLERANCES UNLESS OTHERWISE SPECIFIED: 0 PLC ± 1 PLC ± 2 PLC ± 3 PLC ± 4 PLC ± ANGLES ± MATERIAL: - FINISH: -		NAME: Ocean End Feed Applicator PRODUCT SPEC: - APPLICATION SPEC: - SIZE: A1 CAGE CODE: 00779 DRAWING NO: C=2150256 WEIGHT: - SCALE: 1:1	RESTRICTED TO: - SHEET 2 OF 4 REV C1
Customer Accessible Production Drawing			

PART NUMBER	REVISION	DESCRIPTION	FEED TYPE
2-2150256-2	C	FINE CRIMP HEIGHT ADJUST	PNEUMATIC
7-2150256-7	A	CRIMP TOOLING KIT	-

PACIFIC VERSION TERMINATOR
 INTERFACE ADAPTER

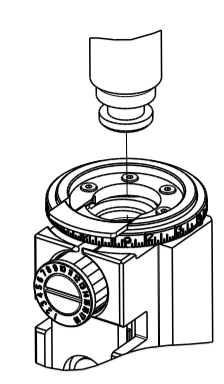

APPLICATOR DATA		
CRIMP	SIZE	TYPE
WIRE	3.05 mm [.120]	F
INSUL	4.06 mm [.160]	F
APPLICATOR INSTRUCTIONS 408-35043		

TERMINAL DATA: METALLON TERMINAL TE CRIMP SPECIFICATION			
TERMINAL NAME: RING TERMINAL			
WIRE STRIP LENGTH		INSULATION DIAMETER RANGE	
4.70 - 5.08mm [.185-.200 IN]		∅ 1.52-2.87mm [.060 - .113]	
TERMINAL APPLICATION SPECIFICATION	114-2065	-	-
TERMINALS APPLIED			
TE TERMINAL	METALLON TERMINAL	TE TERMINAL	LEAR TERMINAL
2113265-1	139-6914	2113265-2	101614-K02
2113265-3	139-6913	2113265-4	101617-K02
2113265-5	101614-K01	2113265-6	101614-K17
2113265-7	101620-K01	2113265-8	101620-K02
2113265-9	101620-K17	1-2113265-0	101617-K01
1-2113265-1	101617-K17	1-2113265-2	101619-K01
1-2113265-3	101619-K02	1-2113265-4	101619-K17
1-2113265-5	101625-K01	1-2113265-6	101625-K02
1-2113265-7	101625-K17	1-2113265-8	101626-K01
1-2113265-9	101626-K02	2-2113265-0	101626-K17

WIRE SIZE	CRIMP HEIGHT mm [INCH]	CRIMP HEIGHT REFERENCE SETTING
18 AWG	1.91+/-0.05 [.075+/-0.002]	2.6
20 AWG	1.80+/-0.05 [.071+/-0.002]	4.0

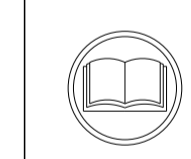

- 1 RECOMMENDED SPARE PARTS
- 2 REFER TO SUPPLIED INSTRUCTION SHEET FOR CLEANING, LUBRICATION AND STORAGE OF APPLICATOR.
- 3 APPLY PART NUMBER 2-23419-6 LOCTITE TO THREADS OF ITEM 242. APPLY PART NUMBER 1-23419-5 LOCTITE TO THREADS OF ITEM 50.
- 4 CRIMP HEIGHT REFERENCE SETTING WAS THE SETTING USED WHEN THE APPLICATOR WAS QUALIFIED AT THE FACTORY. ADJUSTMENT MAY BE NECESSARY WHEN RUNNING APPLICATOR IN THE FIELD.
- 5 TERMINAL PITCH NOT COMPATIBLE WITH MECHANICAL FEED.
- 6. UNLESS SPECIFIED OTHERWISE TORQUE VALUES SHALL BE USED PER DOCUMENT, 101-35000.

LOC	DIST	REVISIONS					
A	66	P	LTN	DESCRIPTION	DATE	DWN	APVD
-	-	-	-	SEE SHEET 1	-	-	-

-	1	2119082-9	CAM, SNAIL, INSULATION ADJUSTMENT	244
-	1	2079764-1	WASHER, WAVE SPRING, CREST-TO-CREST	243
-	1	2119083-1	RETAINER, INSULATION DIAL	242
-	1	2844940-3	AIR FEED MODULE	238
-	1	1-18028-0	WASHER, FLAT, REG M8	192
-	4	2079383-9	SCR, BHSC, RoHS (M6 X 20)	186
-	1	6-993111-6	PIN, SLOTTED SPRING 3.0 X 14.0	177
-	1	8-22280-7	SPRING, COMPRESSION	176
-	1	1752353-2	GUIDE PIN,HOLDDOWN	175
-	1	1901680-2	GUIDE PIN,HOLDDOWN	174
-	REF	994970-2	COUNTER, MAGNETIC	164
-	1	2119641-2	FEED CAM, AIR FEED	152
-	1	2168083-8	SCR, SKT HD CAP, RoHS, M4 X 16	144
-	1	2119655-6	APPLICATOR BASIC ASSEMBLY, EF	141
-	1	1803518-1	RAM ASSEMBLY, EF PACIFIC	140
-	1	455888-5	SPACER, CRIMPER	82
-	1	2119791-9	DEPRESSOR, WIRE	73
-	1	1803607-4	DOCUMENTATION PACKAGE	71
-	2	2-18032-2	SCR, SET, FLT PNT, M3 X 10.0	70
-	1	2119740-1	TAG, IDENTIFICATION	67
-	2	2168078-1	SCREW, DRIVE, RH, RoHS, 2 x .188	66
-	1	1901681-5	HOLDDOWN, TERMINAL	65
-	1	5-18022-5	SCR, HEX HD CAP, M4 X 6.0	59
-	4	2168400-4	SHCS, LOW HEAD, RoHS, M4 X 8	57
-	2	2-2168083-5	SCR, SKT HD CAP, RoHS, M4 X 14	56
-	2	5018030-1	NUT, HEX, REG, RoHS, M3	54
-	2	986965-8	NUT, LOCK, HEX, TORQUE (M4)	53
-	1	1-5018030-0	NUT, HEX, REG, RoHS, M3.5	52
-	1	2063961-1	FEED FINGER	51
-	1	1752354-2	STANDOFF,HOLD-DOWN	50
-	1	18023-9	SCR, SKT HD CAP M4 X 6.0	49
-	1	1803602-1	SCR, BHSC, RoHS (M8 X 25)	41
-	8	1-18028-2	WASHER, FLAT, REG M4	33
-	2	2168083-9	SCR, SKT HD CAP, RoHS, M4 X 20	31
-	2	2168083-2	SCR, SKT HD CAP, RoHS, M4 X 8.0	29
-	1	240639-1	STRIPPER (MACHINING)	27
-	2	1-2168083-5	SCR, SKT HD CAP, RoHS, M4 X 30	25
-	1	1752371-5	PLATE, STRIP GUIDE	24
-	2	2-22281-3	SPRING, COMPRESSION	22
-	1	1803292-1	DRAG	20
-	1	1901696-3	STRIP GUIDE, REAR	19
-	1	1901695-3	STRIP GUIDE, FRONT	18
-	1	1752360-1	SPACER,HOLD-DOWN	13
-	1	240644-1	PLATE, REAR SHEAR	11
-	-	-	-	10
-	1	690482-1	PLATE, FRONT SHEAR	9
-	1	1803060-1	ANVIL, COMBINATION, END FEED	8
-	1	690474-2	BLADE, SLUG	7
-	1	7-240641-2	SPACER	5
-	1	238011-2	BLOCK, CRIMPER SPACER	4
-	1	2-1633961-3	CRIMPER, INSULATION F PREMIUM	3
-	1	455888-3	SPACER, CRIMPER	2
-	1	456409-3	CRIMPER, WIRE .120 "F" PREMIUM	1
-	77-22	PART NO	DESCRIPTION	ITEM NO

***WARNING**
 ON INSTALLATION, SET WIRE DISC TO CRIMP HEIGHT REFERENCE SETTING FOR LARGEST WIRE SIZE. CRIMP HEIGHT REFERENCE SETTINGS GREATER THAN THE VALUE SHOWN MAY CAUSE DAMAGE TO THE CRIMP TOOLING. REFER TO THE INSTRUCTION SHEET FOR PROPER SETUP AND ADJUSTMENTS.

PACIFIC VERSION
 Shown on sheets 3 of 4 & 4 of 4
 (Atlantic version shown on sheets 1 of 4 & 2 of 4)

DIMENSIONS: mm 		TOLERANCES UNLESS OTHERWISE SPECIFIED: 0 PLC ± 1 PLC ± 2 PLC ± 3 PLC ± 4 PLC ± ANGLES ± FINISH		DWN: R. STAKEM 03MAY2012 CHK: G. BAILEY 03MAY2012 APVD: T. ELBIN 03MAY2012		NAME: Ocean End Feed Applicator SIZE: A1 CAGE CODE: 00779 DRAWING NO: 2150256 SCALE: 1:1 SHEET: 3 OF 4 REV: C1	
MATERIAL: -		WEIGHT: -		Customer Accessible Production Drawing		RESTRICTED TO: -	

LOC	DIST	REVISIONS			
P	LTN	DESCRIPTION	DATE	DMN	APVD
A	66	SEE SHEET 1	-	-	-

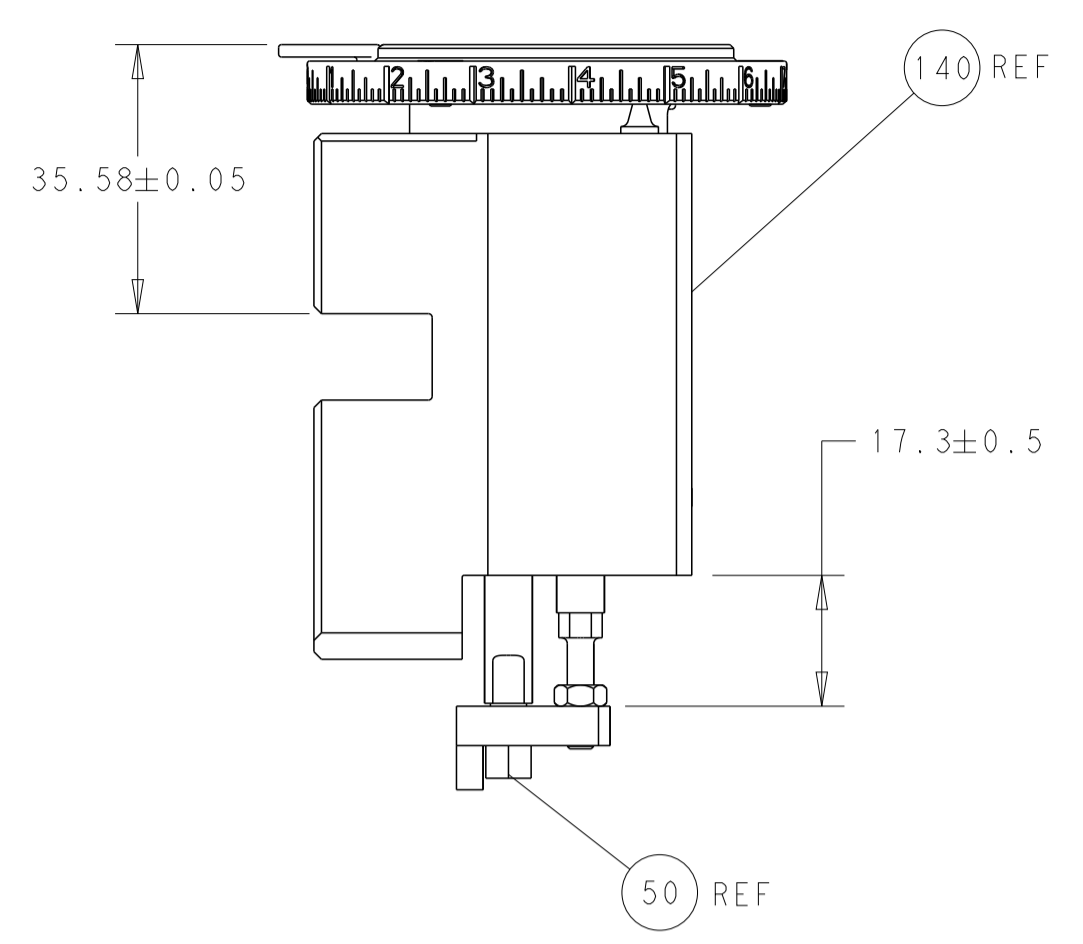

RAM AND HOLDDOWN SET-UP

FEED TYPE

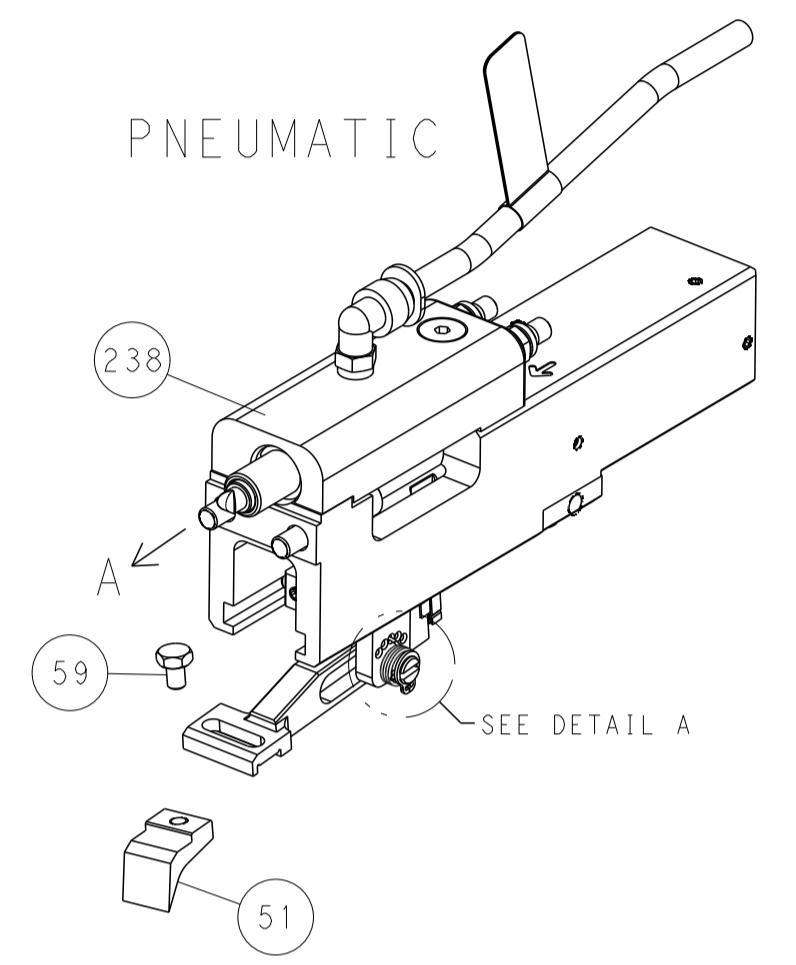

FEED SPRING SETTING POSITION

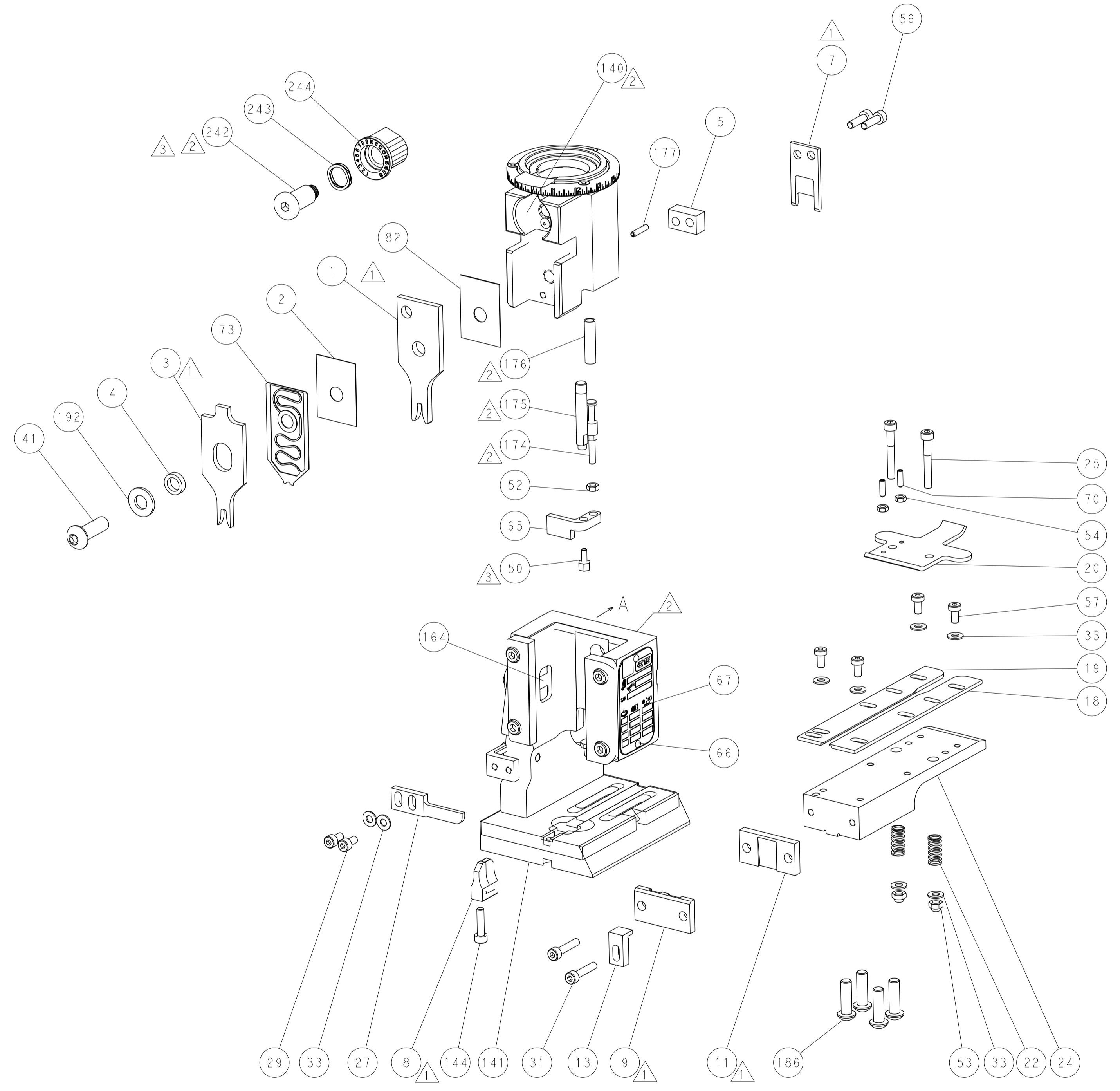
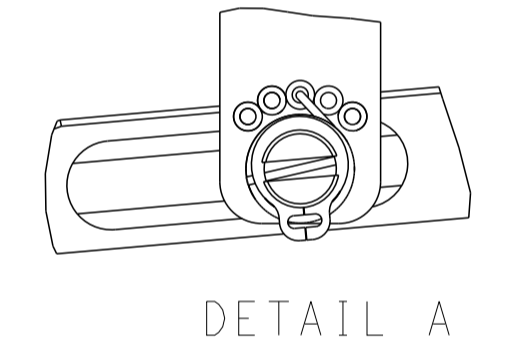

CAM POSITION

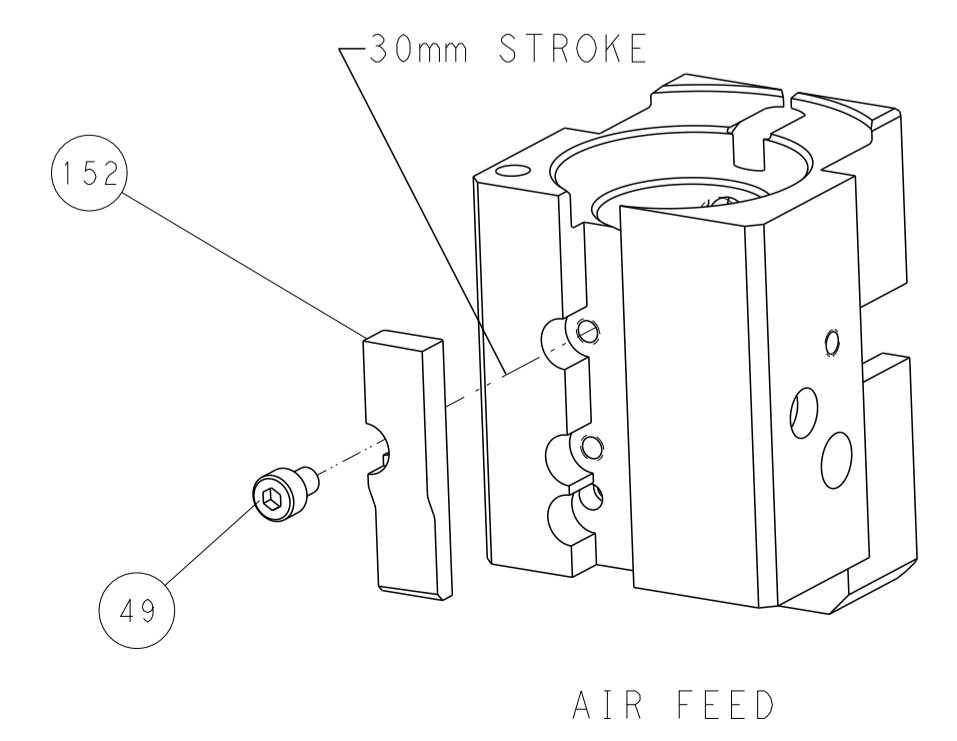

PACIFIC VERSION
 Shown on sheets 3 of 4 & 4 of 4
 (Atlantic version shown on sheets 1 of 4 & 2 of 4)

<small>THIS DRAWING IS UNPUBLISHED. RELEASED FOR PUBLICATION BY TYCO ELECTRONICS CORPORATION. ALL RIGHTS RESERVED.</small>		DWN: K. STAKEM 03MAY2012 CHK: G. BAILEY 03MAY2012 APVD: T. ELBIN 03MAY2012	TE Connectivity Harrisburg, PA 17105-3608
DIMENSIONS: mm TOLERANCES UNLESS OTHERWISE SPECIFIED: 0 PLC ±. 1 PLC ±. 2 PLC ±. 3 PLC ±. 4 PLC ±. ANGLES ±. MATERIAL: . FINISH: .		NAME: Ocean End Feed Applier APPLICATION SPEC: . PRODUCT SPEC: . SIZE: A1 CAGE CODE: 00779 DRAWING NO: C=2150256 WEIGHT: . SCALE: 1:1 SHEET: 4 OF 4 REV: C1	RESTRICTED TO: .