

10W CONVECTION COOLED

The F Series is a broad line of robust, field-proven DC to HV DC converters which deliver 10 Watts continuous output power. Outputs range from 100V to 12kV. The input and output are galvanically isolated so a unit can be used to deliver a positive or negative high voltage output. The output voltage is proportional to input voltage with a low 0.7V typical turn-on voltage.

The F Series employs a quasi-sinewave oscillator, a fully enclosed transformer, input and output filtering, and a 5-sided metal enclosure. As a result, these modules exhibit very low EMI/RFI, noise and ripple. A dual output option has a center-tap pin which, when grounded provides both positive and negative outputs from one compact module.

DC-HVDC CONVERTER



Features

- Output Voltages from 100V to 12kV
- Output Voltage Proportional to Input
- Low Turn-on Voltage 0.7VDC
- Input to Output Isolation
- Dual Output Option
- Arc & Short Circuit Protected
- No Minimum Load
- 3 Year Warranty

Typical Applications



- Mass Spectrometry
- Electrostatic Chucks
- Electrophoresis
- Capacitor Charging
- Particle Counter
- Isolation Testing
- Medical Laser Treatment

Dimensions

2.80 x 1.70 x 0.85" (71.1 x 43.2 x 21.6mm)

Block Diagram

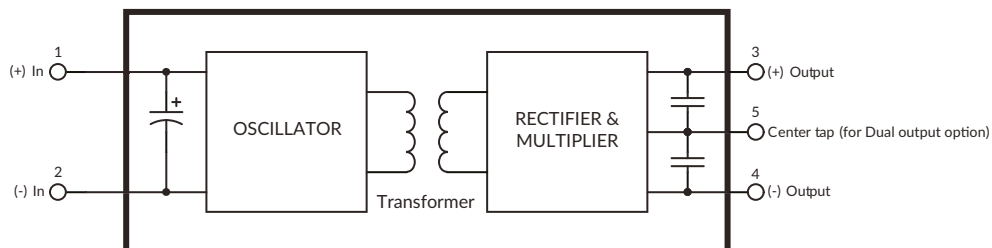

Input

Characteristic	Minimum	Typical	Maximum	Units	Notes & Conditions
Input Voltage Range	0.7		12, 15	VDC	See Models & Ratings table
Input Current, No Load			500	mA	
Input Current, Full Load			1.5	A	

Output

Characteristic	Minimum	Typical	Maximum	Units	Notes & Conditions
Output Voltage			12 000	VDC	See Models & Ratings table
Output Current			100	mA	See Models & Ratings table
Output Voltage Tolerance		±5		%	At Max Vout, Full Load
Minimum Load	No minimum load required				
Regulation	Unregulated, Output is proportional to Input. See Application Notes				
Short Circuit Protection	Protected against short circuit conditions indefinitely				
Ripple and Noise	0.1		2.5	%	1 See Models & Ratings table
Response Time			260	msec	0 to Max Vout, Full Load

General

Characteristic	Minimum	Typical	Maximum	Units	Notes & Conditions
Isolation: Input to Output			3500	V	<±3,500 Bias for Models F01 to F60
Isolation: Input to Output			500	V	<±500 Bias for Models F70 to F121
Switching Frequency	25		125	kHz	Stable frequency over entire output voltage range.
Construction	Case material is black anodized aluminum. UL 94 V-0 rated solid vacuum encapsulation.				
Mean Time Between Failure	810			khrs	Bellcore TR 332

Environmental

Characteristic	Minimum	Typical	Maximum	Units	Notes & Conditions
Operating Temperature	-10		+70	°C	Standard operating temperature
Storage Temperature	-25		+90	°C	
Cooling	Natural convection				
Humidity			95	%RH	Non-condensing

Notes:

- Maximum rated output current is available at maximum rated output voltage and derates linearly as input voltage is decreased.
- Output voltage is load dependent. Under light or no-load conditions, reduce the input voltage so maximum rated output voltage is not exceeded.
- Specifications after 1 hour warm-up, full load, at 25°C unless otherwise indicated.
- Proper thermal management techniques are required to maintain safe case temperature at maximum power output.
- Ripple specification for center-tapped units applies to the voltage between the positive and negative output terminals.

Models & Ratings

Model Number	Output Voltage	Output Current ⁽¹⁾	Input Voltage	Ripple
F01	0 to 100V	100mA	0 to 12V	<0.6%
F02	0 to 200V	50mA	0 to 12V	<1.0%
F02CT	0 +/-100V	50mA	0 to 12V	<1.0%
F02RH	0 to 200V	50mA	0 to 12V	<1.0%
F03	0 to 300V	33.3mA	0 to 12V	<1.0%
F03CT	0 to +/-150V	33.3mA	0 to 12V	<1.0%
F03H	0 to 300V	33.3mA	0 to 12V	<1.0%
F04	0 to 400V	25mA	0 to 12V	<1.0%
F04CT	0 to +/-200V	25mA	0 to 12V	<1.0%
F04CTH	0 to +/-200V	25mA	0 to 12V	<1.0%
F04H	0 to 400V	25mA	0 to 12V	<1.0%
F05	0 to 500V	20mA	0 to 12V	<0.1%
F05H	0 to 500V	20mA	0 to 12V	<0.1%
F06	0 to 600V	16mA	0 to 12V	<0.1%
F06CT	0 to +/-300V	16mA	0 to 12V	<0.1%
F08	0 to 800V	12.5mA	0 to 12V	<0.1%
F10	0 to 1000V	10mA	0 to 12V	<0.1%
F10CT	0 to +/-500V	10mA	0 to 12V	<0.1%
F12	0 to 1200V	8.3mA	0 to 12V	<0.1%
F12CT	0 to +/-600V	8.3mA	0 to 12V	<0.1%
F15	0 to 1500V	6.6mA	0 to 12V	<0.1%
F15CTH	0 to +/-750V	6.6mA	0 to 12V	<0.1%
F15H	0 to 1500V	6.6mA	0 to 12V	<0.1%
F20	0 to 2000V	5mA	0 to 12V	<1.0%
F30	0 to 3000V	3.3mA	0 to 15V	<1.0%
F30CT	0 to +/-1500V	3.3mA	0 to 15V	<1.0%
F30H	0 to 3000V	3.3mA	0 to 15V	<1.0%
F40	0 to 4000V	2.5mA	0 to 15V	<1.0%
F40CT	0 to +/-2000V	2.5mA	0 to 15V	<1.0%
F50	0 to 5000V	2mA	0 to 15V	<1.0%
F50CT	0 to +/-2500V	2mA	0 to 15V	<1.0%
F60	0 to 6000V	1.66mA	0 to 15V	<1.0%
F60CT	0 to +/-3000V	1.66mA	0 to 15V	<1.0%
F60H	0 to 6000V	1.66mA	0 to 15V	<1.0%
F80	0 to 8000V	1.25mA	0 to 15V	<2.5%
F80CT	0 to +/-4000V	1.25mA	0 to 15V	<2.5%
F101R	0 to 10,000V	1mA	0 to 15V	<2.5%
F121	0 to 12,000V	0.83mA	0 to 15V	<2.5%
F121CT	0 to +/-6000V	0.83mA	0 to 15V	<2.5%

Notes:

1. All orderable part numbers are listed above.
 2. CT indicates dual output, center tap.

3. H suffix indicates drilled mounting holes for F01 to F60.
 4. R suffix is used as a RoHS indicator for legacy models.

Case Temperature Hot Spot

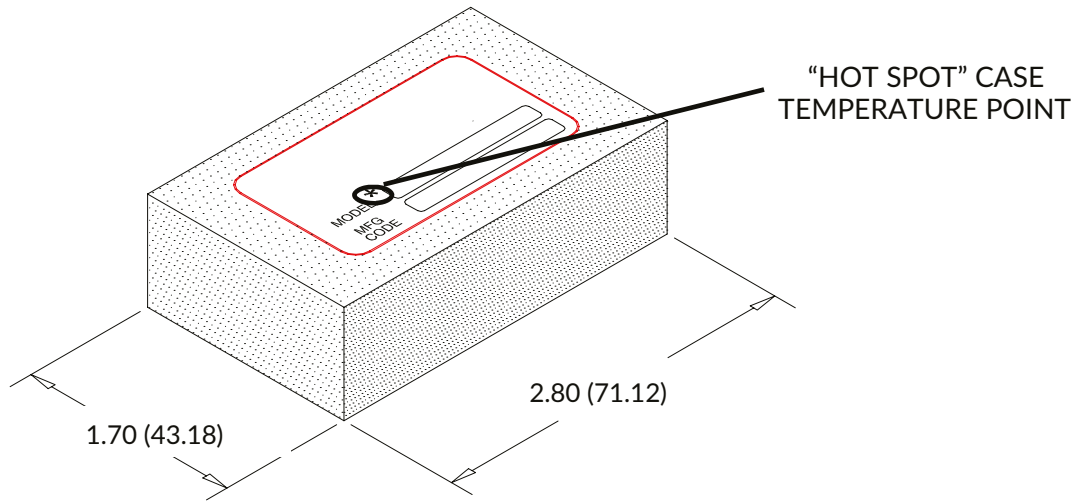

Mechanical Details

F01-F60

Top View

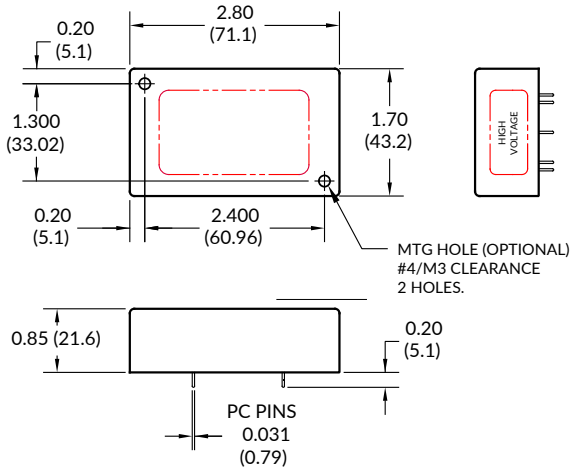

PCB Layout

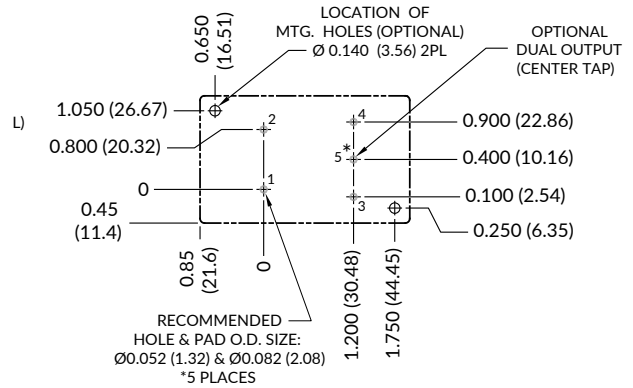

F80-F121

Top View

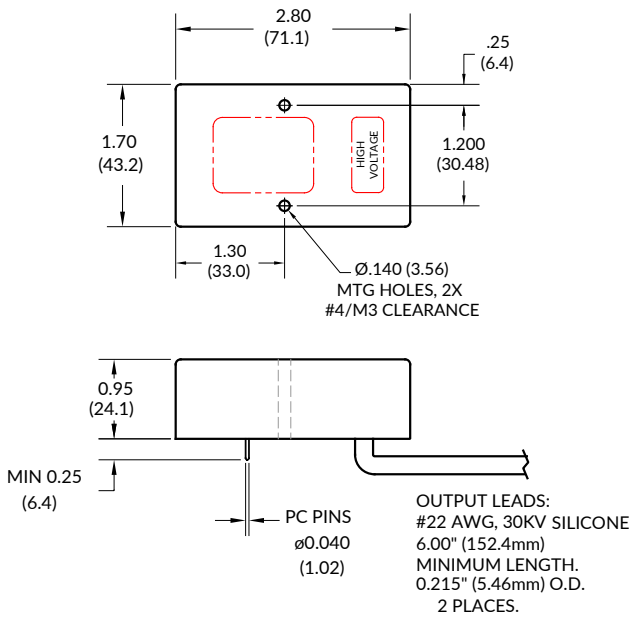

PCB Layout

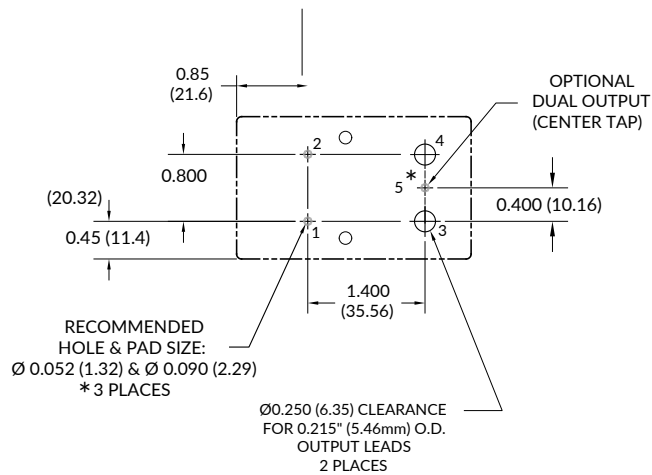

Pin	Function
1	(+) Input
2	(-) Input
3	(+) Output
4	(-) Output
5	Dual Output/Center Tap (Optional)

Notes:

- All dimensions are in inches (mm)
- Weight 5oz (142g)
- Tolerance: X.XX±0.02 (0.51)
- Pin Tolerance: ±0.005 (0.127)
- Case is internally connected to (-) Input.

Mounting Kit

Positive Output

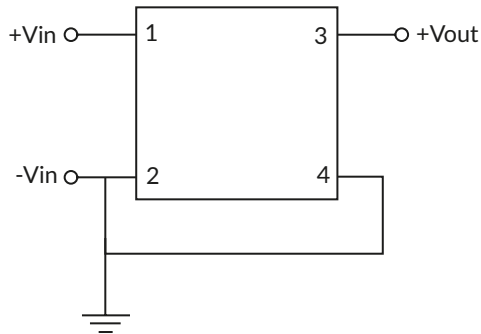

Negative Output

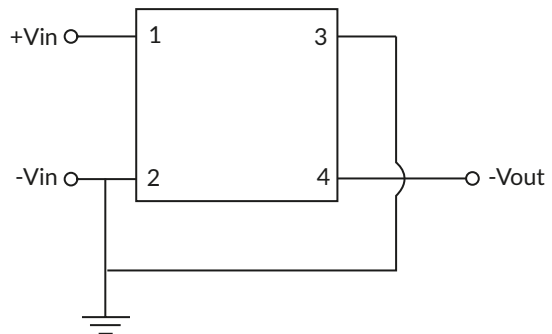

Dual Output

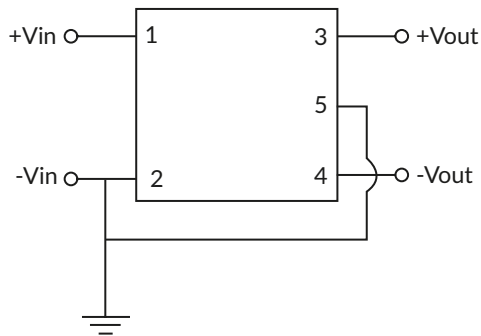

Output Voltage vs. Input Voltage

