

AFBR-0545Z Fast Ethernet Media Converter Board with the AFBR-5972Z Transceiver



Application Note 5549

Introduction

The Avago AFBR-5972Z transceiver module enables system designer to implement a 100 Mbps Fast Ethernet data link over standard plastic optical fiber (POF, NA = 0.5). The AFBR-0545Z media converter board allows a system designer to quickly evaluate AFBR-5972Z transceiver module performance. The transceiver module can be connected with Avago Versatile Link connectors (AFBR-4526Z). The AFBR-5972Z module is lead free and RoHS compatible.

AFBR-0545Z Media Converter Kit

The media converter kit includes:

1. Media converter board (2 pieces)
2. 12V DC power supply (2 pieces) plus power supply adapter (5 types, 2 pieces each)
3. 2 meter POF Cable (NA = 0.5) with duplex connector for the AFBR-5972Z (P/N HFBR-RSD002Z)
4. CAT 5 patch cable (2 pieces)
5. AFBR-0545Z application note

As shown in Figure 1, the media converter board includes a twisted pair interface, optical transceiver module, a media converter PHY chip, and power supply interface. The media converter PHY chip translates the data signal from the twisted pair domain to the optical domain.

POF cable has many significant advantages over twisted pair copper media.

- Optical cable is immune to, and does not generate, EM fields.
- Complete galvanic isolation is also achieved using optical communication links.
- Plastic optical fiber (POF) also offers a lower weight media.
- POF offers a low cost cable solution and easy field termination.

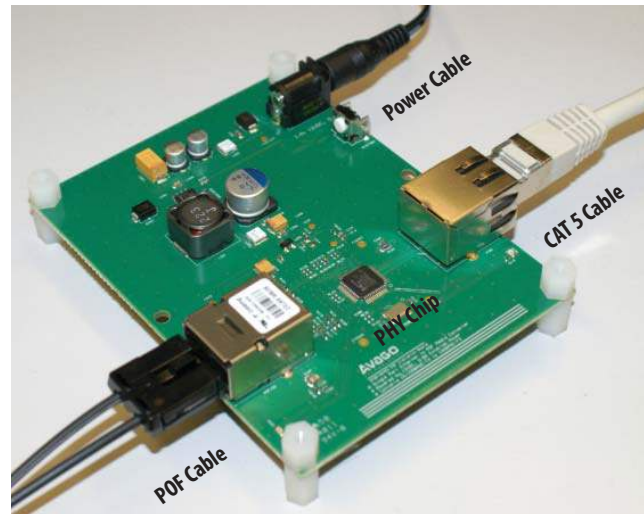

Figure 1. AFBR-0545Z media converter board with the AFBR-5972Z transceiver

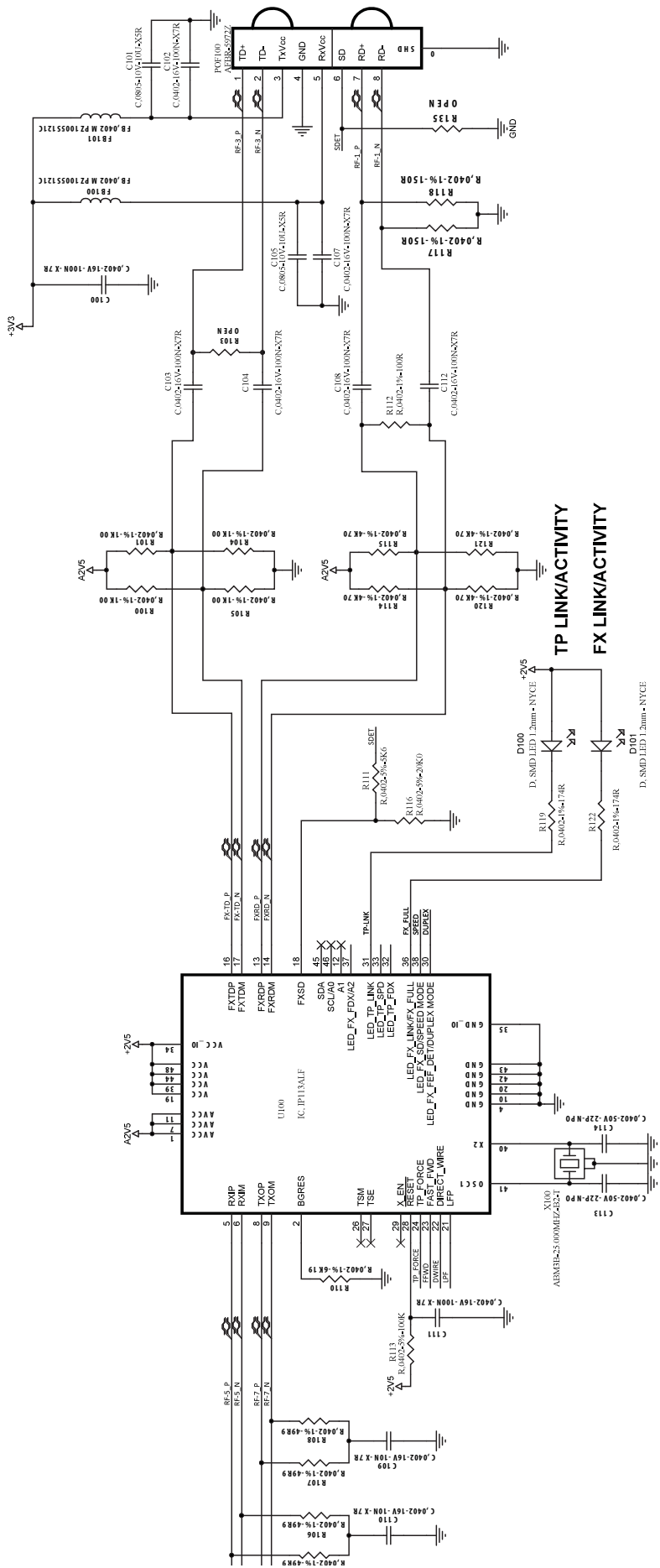

Figure 2. AFBR-0545Z Media converter board schematic

AFBR-0545Z Circuit Design

The schematic for the AFBR-0545Z media converter board is shown in Figure 2. The data signal from the twisted pair medium is routed through magnetic (part of RJ 45 jack) to the IC Plus IP113ALF input media converter input pins (RXIP and RXIM). The IP113ALF is configured for 100 Mbps full duplex mode. The transmitter output of the IP113ALF (FXTDP and FXTDM) is AC coupled to the input of the Avago AFBR-5972Z transceiver module through a differential transmission line with a 100 Ω impedance. Resistor R103 is not populated because AFBR-5972Z has an internal 100 Ω resistor for termination (see AFBR-5972Z data sheet). Resistor R112 provides a 100 Ω termination for the receiver of the AFBR-5972Z module. The voltage divider between the IP113ALF and AFBR-5972Z module biases the IP113ALF PHY chip. Resistors R117 and R118 are needed as termination of the receiver output stage of AFBR-5972Z. The signal detect (SD) output signal of the transceiver module is connected to the PHY chip FXSD pin through the voltage divider formed by resistors R111 and R116. The FXSD pin is active when the threshold voltage is higher than 1.35 V.

LED2 and LED1 (in Figure 3) provides visual information about the presence of supply voltage at AFBR-5972Z module and RJ 45 jack respectively. LED1 also provides information about twisted pair link connection. LED2 provides information about the full duplex optical link connection.

Fast Ethernet Measurement Setup

The Fast Ethernet measurement setup converts the data signal from the twisted pair domain to the optical domain and back again to the twisted pair domain. The Fast Ethernet link is created by connecting the RJ 45 interface of the media converter board to the network through a CAT5 patch cable. The duplex POF cable is connected between the AFBR-5972Z modules, as shown in Figure 4.



Figure 3. AFBR-0545Z media converter evaluation board



Figure 4. Fast Ethernet measurement setup

Packet Loss Measurement using the Ping Command

This procedure checks the functionality of the AFBR-0545Z media converter board and creates an optical link network to measure packet loss.

1. Connect the power supply to the AFBR-0545Z media converter boards. LED1 and LED2 will flash one time and a red light can be seen coming out of the AFBR-5972Z module. This indicates that the media converter boards are functional.
2. Connect one end of CAT 5 patch cable to the RJ45 interface and other end to the network. LED1 will flash on and off. Connect the RJ45 interface of the other media converter board to a computer or a laptop. LED1 will flash on and off.
3. Connect the 2-meter POF duplex cable between the two AFBR-5972Z media converter boards. This makes a duplex communication optical link. LED1 and LED2 on both media converter boards will flash synchronously, indicating an active optical link network has been created.

With the link established, a packet loss measurement can be made with the Internet Ping protocol and ping command.

Internet Ping Command

The Internet ping command bounces a small packet off a domain or IP address to test network communications, and then reports how long the packet took to make the round trip. The ping command is one of the most commonly used utilities on the Internet by both people and automated programs for conducting the most basic network test.

Command Prompt in Windows NT, 2000, and XP

To use the ping command, open a Command Prompt window:

Click **Start** Click **Run** Type **cmd** and press enter

In Command Prompt window type “ping -n 10 avagotech.com”. This means that the ping command will ping avagotech.com ten times (Figure 5).

As shown in Figure 5, the ping command pinged the avagotech website ten times and also provided statistics for the avagotech.com link. For example, the number of packets sent, received and lost as well as the minimum, maximum and average round-trip time in milliseconds were reported. In this example there were no packets lost (0% loss).

For the test shown in Figure 6, the CAT5 patch cable from the media converter board (which is connected to a computer or laptop) was purposely removed to observe the packet loss. The results of the ping command “ping -n 10 avagotech.com” – with the CAT5 patch cable removed – show the packet loss phenomena. Ten packets were sent, six packets were received and four packets failed to reach the destination host. Packet loss was 40%.

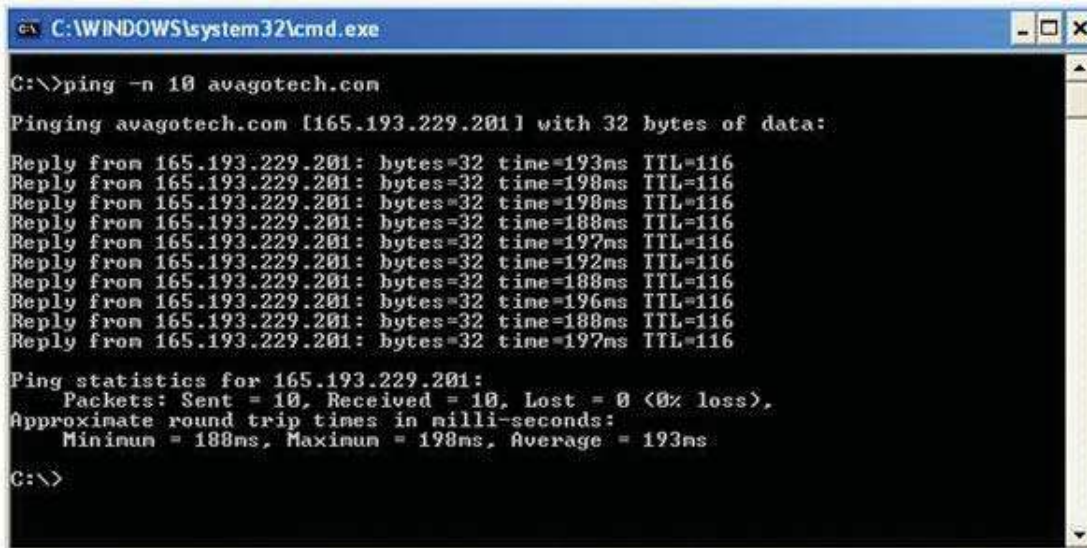

```
C:\WINDOWS\system32\cmd.exe
C:\>ping -n 10 avagotech.com

Pinging avagotech.com [165.193.229.201] with 32 bytes of data:

Reply from 165.193.229.201: bytes=32 time=193ms TTL=116
Reply from 165.193.229.201: bytes=32 time=198ms TTL=116
Reply from 165.193.229.201: bytes=32 time=198ms TTL=116
Reply from 165.193.229.201: bytes=32 time=188ms TTL=116
Reply from 165.193.229.201: bytes=32 time=197ms TTL=116
Reply from 165.193.229.201: bytes=32 time=192ms TTL=116
Reply from 165.193.229.201: bytes=32 time=188ms TTL=116
Reply from 165.193.229.201: bytes=32 time=196ms TTL=116
Reply from 165.193.229.201: bytes=32 time=188ms TTL=116
Reply from 165.193.229.201: bytes=32 time=197ms TTL=116

Ping statistics for 165.193.229.201:
    Packets: Sent = 10, Received = 10, Lost = 0 (0% loss),
    Approximate round trip times in milli-seconds:
        Minimum = 188ms, Maximum = 198ms, Average = 193ms

C:\>
```

Figure 5. Ping statistics for avagotech.com: Packet loss = 0%

```
C:\WINDOWS\system32\cmd.exe
C:\>ping -n 10 avagotech.com
Pinging avagotech.com [165.193.229.201] with 32 bytes of data:
Reply from 165.193.229.201: bytes=32 time=241ms TTL=116
Reply from 165.193.229.201: bytes=32 time=221ms TTL=116
Reply from 165.193.229.201: bytes=32 time=194ms TTL=116
Reply from 165.193.229.201: bytes=32 time=217ms TTL=116
Reply from 165.193.229.201: bytes=32 time=208ms TTL=116
Reply from 165.193.229.201: bytes=32 time=189ms TTL=116
Request timed out.
Request timed out.
Destination host unreachable.
Destination host unreachable.

Ping statistics for 165.193.229.201:
    Packets: Sent = 10, Received = 6, Lost = 4 (40% loss),
    Approximate round trip times in milli-seconds:
        Minimum = 189ms, Maximum = 241ms, Average = 211ms

C:\>
```

Figure 6. Ping statistics for avagotech.com: Packet loss = 40%

References

1. IC Plus Corporation: <http://www.icplus.com.tw/>
2. Avago AFBR-5972Z transceiver data sheet: www.avagotech.com/docs/AV02-2701EN

For product information and a complete list of distributors, please go to our web site: www.avagotech.com

Avago, Avago Technologies, and the A logo are trademarks of Avago Technologies in the United States and other countries. Data subject to change. Copyright © 2005-2012 Avago Technologies. All rights reserved. AV02-3374EN - July 6, 2012

