

Common Mode Choke Coils(Line Filters) for AC Power Supply

Toroidal Core Type TF Series

Conformity to RoHS Directive

TDK common mode choke coils(line filters) are used in a wide range of prevention of electromagnetic interference(EMI) and radio frequency interference(RFI) from power supply lines and for prevention of multifunctioning of products such as measuring equipment and system equipment.

FEATURES

- Wide range of selection.
- High impedance at applicable frequency.
- High self-resonant frequency.

PRODUCT IDENTIFICATION

TF □□□□ V - A □□□Y □R□ - 01
 (1) (2) (3) (4) (5) (6) (7)

- (1) Core shape
TF: Toroidal core
- (2) Dimensional code
Width×Depth
- (3) External shape code
V: Vertical type H: Horizontal type
- (4) High μ material
- (5) Inductance value
Example) 133:13mH
- (6) Rated current value
Example) 3R0:3.0A
- (7) Product management number

SELECTION CHART

Series	Configuration	Type	Inductance value min.	Rated current (A)	Handling power* $L \times I^2$ (mH×A ²)	Weight (g)typ.	Minimum package quantity (pieces/box)
TF	Vertical type	TF1813V	2 to 20mH	0.7 to 3.2	20	5	960
		TF2518V	0.65 to 9mH	2.5 to 10	50	15	560
		TF2721V	1 to 13mH	2.5 to 10	75	20	460
		TF3020V	0.35 to 13mH	3 to 20	130	30	440
		TF3525V	0.65 to 20mH	3 to 20	195	41	240
	Horizontal type	TF1713H	2 to 20mH	0.7 to 3.2	20	5.3	960
		TF2520H	0.65 to 9mH	2.5 to 10	50	15	550
		TF2722H	1 to 13mH	2.5 to 10	75	20	380
		TF3022H	0.35 to 13mH	3 to 20	130	32	320
		TF3526H	0.65 to 20mH	3 to 20	195	42	280
	Vertical type (For high frequency)	TF2628V-1H	25 to 65 μ H	6 to 12	3.65	18	700
		TF3524V-1H	25 to 120 μ H	8 to 20	10.8	40	320

* Handling power=(Inductance value)×(Current)². It is possible to design within the range below this value.
 [Example] The coil for 2A can make even the inductance of 2.5mH or less a product for handling power 10.

• Conformity to RoHS Directive: This means that, in conformity with EU Directive 2002/95/EC, lead, cadmium, mercury, hexavalent chromium, and specific bromine-based flame retardants, PBB and PBDE, have not been used, except for exempted applications.

• All specifications are subject to change without notice.

Horizontal Type TF Series

FEATURES

- This series uses a high permeability toroidal ferrite core and therefore provide large inductance with a little number of turns.
- Therefore its stray capacity is small and it keeps the impedance required to effectively suppress high frequency noises.
- Products mounted on a base with fixed leads are easy to insert to circuit boards.

TF1713H-A(HORIZONTAL TYPE WITH TERMINAL BASE) TYPE SHAPES AND DIMENSIONS/CIRCUIT DIAGRAM

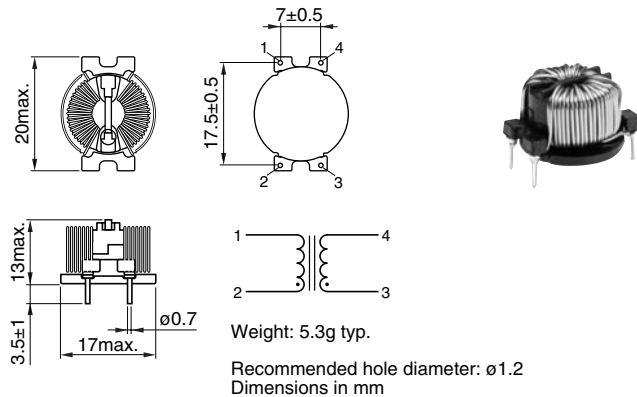

TYPICAL ELECTRICAL CHARACTERISTICS IMPEDANCE vs. FREQUENCY CHARACTERISTICS

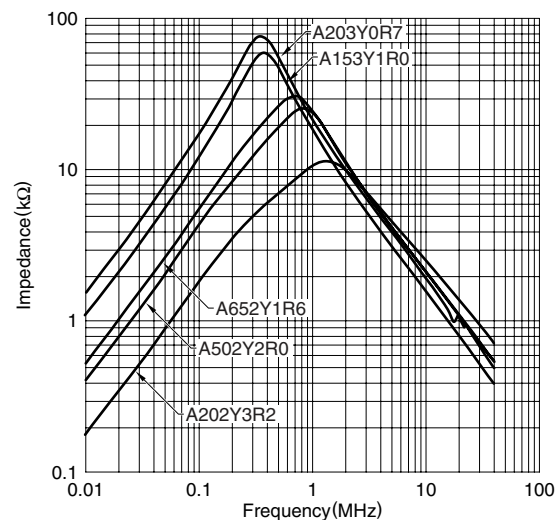

ELECTRICAL CHARACTERISTICS (STANDARD LINE UP)

Part No.	Inductance (mH)min.	DC resistance (Ω)max.	Rated current Iac(A)max.
TF1713H-A203Y0R7-01	20	0.73	0.7
TF1713H-A153Y1R0-01	15	0.44	1
TF1713H-A652Y1R6-01	6.5	0.19	1.6
TF1713H-A502Y2R0-01	5	0.14	2
TF1713H-A202Y3R2-01	2	0.065	3.2

- Measuring equipment of inductance value:
LCR meter(HP4261A, HP4263B or equivalent)[f=1kHz]

PACKAGING QUANTITIES

TF1713H-A	960pieces/box
-----------	---------------

RATINGS

Item	Standard value	Conditions
Rated voltage(V)	80 to 280	50Hz/60Hz
Dielectric withstanding voltage(V)	2000	Between each winding for 1 minute
Insulation resistance (M Ω)	100min.	Between each winding for DC.500V
Temperature rise($^{\circ}$ C)	45max.	With line resistance
Operating temperature range($^{\circ}$ C)	-20 to +120	Including self-temperature rise
Storage temperature range($^{\circ}$ C)	-20 to +85	
Resistance to soldering temperature*1	260 \pm 5 $^{\circ}$ C, 10 \pm 1sec	Solder bath method
Applicable safety standard*2	350 \pm 5 $^{\circ}$ C, 5sec max.	Soldering iron method
	Electrical Appliance and Material Safety Law ("DENAN"), IEC60065, UL6500, CSA C22.2	

*1 Pb free solder(Sn-3Ag-0.5Cu)

*2 However, this product is not recognized by each regulations.

TF2520H-A(HORIZONTAL TYPE WITH TERMINAL BASE) TYPE SHAPES AND DIMENSIONS/CIRCUIT DIAGRAM

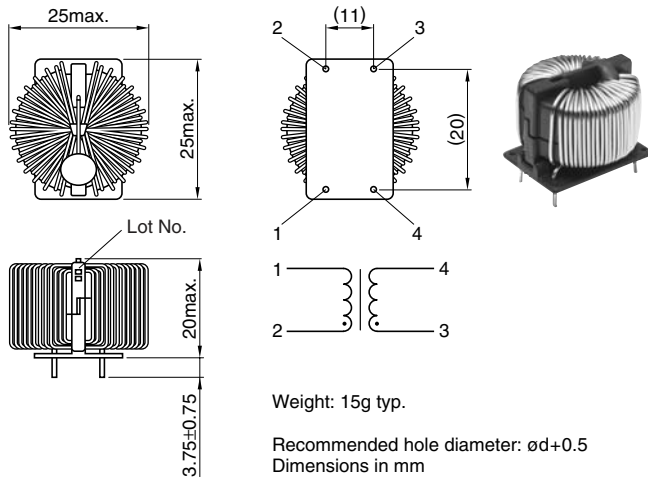

TYPICAL ELECTRICAL CHARACTERISTICS IMPEDANCE vs. FREQUENCY CHARACTERISTICS

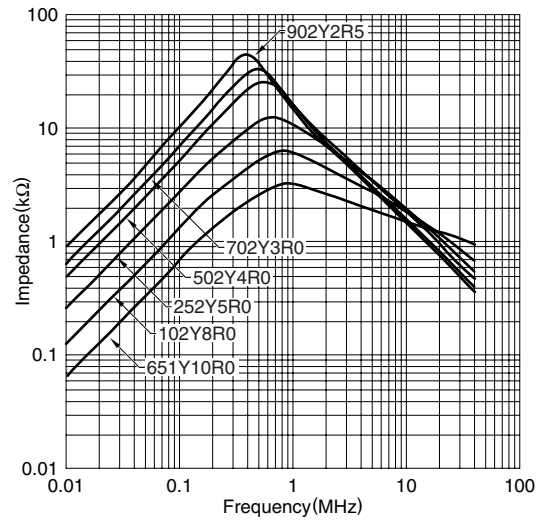

ELECTRICAL CHARACTERISTICS (STANDARD LINE UP)

Part No.	Inductance (mH)min.	DC resistance (Ω)max.	Rated current Iac(A)max.	ϕd (mm)
TF2520H-A902Y2R5-01	9	0.12	2.5	0.6
TF2520H-A702Y3R0-01	7	0.095	3	0.65
TF2520H-A502Y4R0-01	5	0.075	4	0.7
TF2520H-A252Y5R0-01	2.5	0.05	5	0.75
TF2520H-A102Y8R0-01	1	0.025	8	0.95
TF2520H-A651Y10R0-01	0.65	0.02	10	1

- Measuring equipment of inductance value:
LCR meter(HP4261A, HP4263B or equivalent)[f=1kHz]

PACKAGING QUANTITIES

TF2520H-A	550pieces/box
-----------	---------------

RATINGS

Item	Standard value	Conditions
Rated voltage(V)	80 to 280	50Hz/60Hz
Dielectric withstanding voltage(V)	2000	Between each winding for 1 minute
Insulation resistance (M Ω)	100min.	Between each winding for DC.500V
Temperature rise($^{\circ}$ C)	45max.	With line resistance
Operating temperature range($^{\circ}$ C)	-20 to +120	Including self-temperature rise
Storage temperature range($^{\circ}$ C)	-20 to +85	
Resistance to soldering temperature*1	260 \pm 5 $^{\circ}$ C, 10 \pm 1sec	Solder bath method
Applicable safety standard*2	350 \pm 5 $^{\circ}$ C, 5sec max.	Soldering iron method
	Electrical Appliance and Material Safety Law ("DENAN"), IEC60065, UL6500, CSA C22.2	

*1 Pb free solder(Sn-3Ag-0.5Cu)

*2 However, this product is not recognized by each regulations.

TF2722H-A(HORIZONTAL TYPE WITH TERMINAL BASE) TYPE SHAPES AND DIMENSIONS/CIRCUIT DIAGRAM

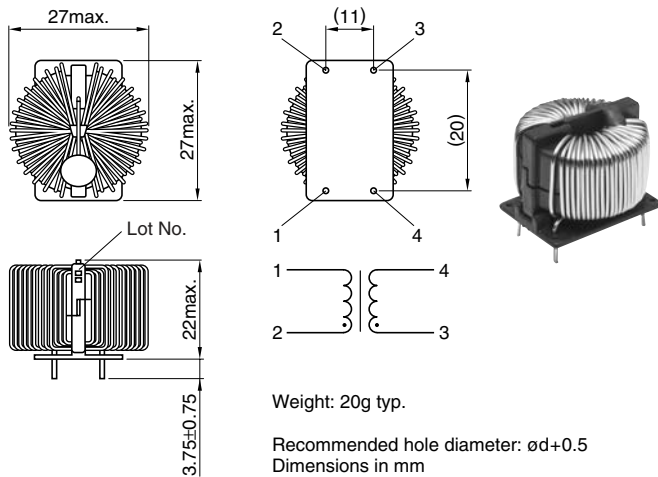

ELECTRICAL CHARACTERISTICS (STANDARD LINE UP)

Part No.	Inductance (mH)min.	DC resistance (m Ω)max.	Rated current Iac(A)max.	ϕd (mm)
TF2722H-A133Y2R5-01	13	130	2.5	0.65
TF2722H-A103Y3R0-01	10	90	3	0.7
TF2722H-A652Y4R0-01	6.5	60	4	0.8
TF2722H-A422Y5R0-01	4.2	40	5	0.9
TF2722H-A152Y8R0-01	1.5	20	8	1
TF2722H-A102Y10R0-01	1	11	10	1.2

- Measuring equipment of inductance value:
LCR meter(HP4261A, HP4263B or equivalent)[f=1kHz]

PACKAGING QUANTITIES

TF2722H-A	380pieces/box
-----------	---------------

TYPICAL ELECTRICAL CHARACTERISTICS IMPEDANCE vs. FREQUENCY CHARACTERISTICS

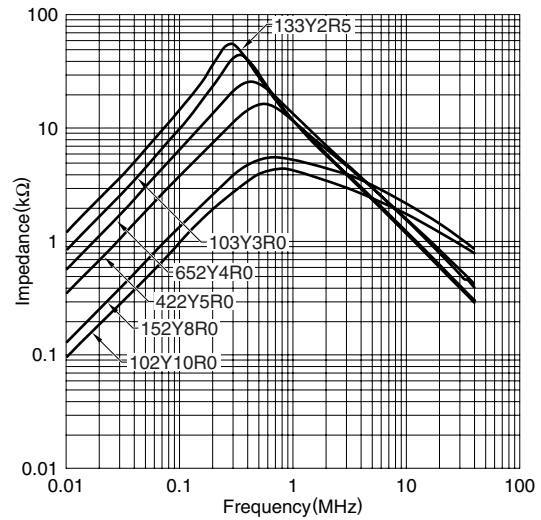

RATINGS

Item	Standard value	Conditions
Rated voltage(V)	80 to 280	50Hz/60Hz
Dielectric withstanding voltage(V)	2000	Between each winding for 1 minute
Insulation resistance (M Ω)	100min.	Between each winding for DC.500V
Temperature rise($^{\circ}$ C)	45max.	With line resistance
Operating temperature range($^{\circ}$ C)	-20 to +120	Including self-temperature rise
Storage temperature range($^{\circ}$ C)	-20 to +85	
Resistance to soldering temperature*1	260 \pm 5 $^{\circ}$ C, 10 \pm 1sec	Solder bath method
Applicable safety standard*2	350 \pm 5 $^{\circ}$ C, 5sec max.	Soldering iron method
	Electrical Appliance and Material Safety Law ("DENAN"), IEC60065, UL6500, CSA C22.2	

*1 Pb free solder(Sn-3Ag-0.5Cu)

*2 However, this product is not recognized by each regulations.

TF3022H-A(HORIZONTAL TYPE WITH TERMINAL BASE) TYPE SHAPES AND DIMENSIONS/CIRCUIT DIAGRAM

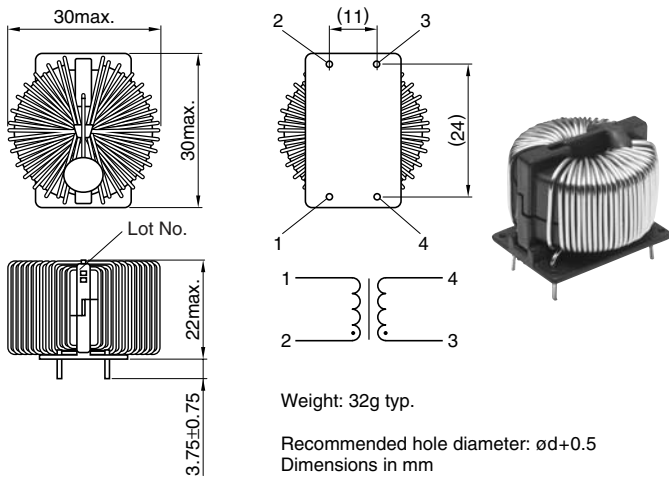

TYPICAL ELECTRICAL CHARACTERISTICS IMPEDANCE vs. FREQUENCY CHARACTERISTICS

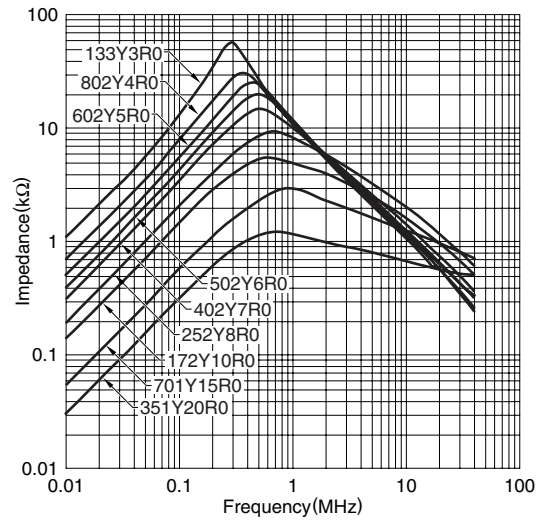

ELECTRICAL CHARACTERISTICS (STANDARD LINE UP)

Part No.	Inductance (mH)min.	DC resistance (Ω)max.	Rated current lac(A)max.	ød (mm)
TF3022H-A133Y3R0-01	13	0.1	3	0.75
TF3022H-A802Y4R0-01	8	0.07	4	0.8
TF3022H-A602Y5R0-01	6	0.05	5	0.9
TF3022H-A502Y6R0-01	5	0.04	6	0.95
TF3022H-A402Y7R0-01	4	0.035	7	1
TF3022H-A252Y8R0-01	2.5	0.025	8	1.1
TF3022H-A172Y10R0-01	1.7	0.015	10	1.3
TF3022H-A701Y15R0-01	0.7	0.007	15	1.6
TF3022H-A351Y20R0-01	0.35	0.005	20	1.7

• Measuring equipment of inductance value:
LCR meter(HP4261A, HP4263B or equivalent)[f=1kHz]

PACKAGING QUANTITIES

TF3022H-A	320pieces/box
-----------	---------------

RATINGS

Item	Standard value	Conditions
Rated voltage(V)	80 to 280	50Hz/60Hz
Dielectric withstanding voltage(V)	2000	Between each winding for 1 minute
Insulation resistance (MΩ)	100min.	Between each winding for DC.500V
Temperature rise(°C)	45max.	With line resistance
Operating temperature range(°C)	-20 to +120	Including self-temperature rise
Storage temperature range(°C)	-20 to +85	
Resistance to soldering temperature*1	260±5°C, 10±1sec	Solder bath method
Applicable safety standard*2	350±5°C, 5sec max.	Soldering iron method
	Electrical Appliance and Material Safety Law ("DENAN"), IEC60065, UL6500, CSA C22.2	

*1 Pb free solder(Sn-3Ag-0.5Cu)

*2 However, this product is not recognized by each regulations.

TF3526H-A(HORIZONTAL TYPE WITH TERMINAL BASE) TYPE SHAPES AND DIMENSIONS/CIRCUIT DIAGRAM

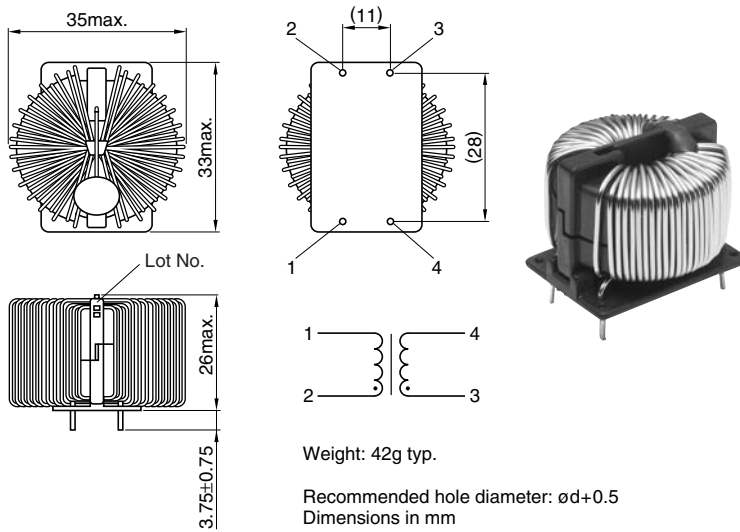

TYPICAL ELECTRICAL CHARACTERISTICS IMPEDANCE vs. FREQUENCY CHARACTERISTICS

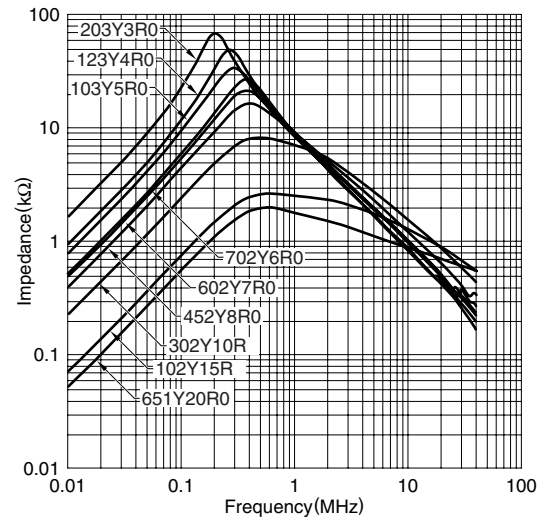

ELECTRICAL CHARACTERISTICS (STANDARD LINE UP)

Part No.	Inductance (mH)min.	DC resistance (mΩ)max.	Rated current Iac(A)max.	φd (mm)
TF3526H-A203Y3R0-01	20	130	3	0.75
TF3526H-A123Y4R0-01	12	75	4	0.85
TF3526H-A103Y5R0-01	10	55	5	0.95
TF3526H-A702Y6R0-01	7	45	6	1
TF3526H-A602Y7R0-01	6	35	7	1.1
TF3526H-A452Y8R0-01	4.5	25	8	1.2
TF3526H-A302Y10R0-01	3	18	10	1.3
TF3526H-A102Y15R0-01	1	6	15	1.7
TF3526H-A651Y20R0-01	0.65	4	20	1.8

- Measuring equipment of inductance value:
LCR meter(HP4261A, HP4263B or equivalent)[f=1kHz]

PACKAGING QUANTITIES

TF3526H-A	280pieces/box
-----------	---------------

RATINGS

Item	Standard value	Conditions
Rated voltage(V)	80 to 280	50Hz/60Hz
Dielectric withstanding voltage(V)	2000	Between each winding for 1 minute
Insulation resistance (MΩ)	100min.	Between each winding for DC.500V
Temperature rise(°C)	45max.	With line resistance
Operating temperature range(°C)	-20 to +120	Including self-temperature rise
Storage temperature range(°C)	-20 to +85	
Resistance to soldering temperature*1	260±5°C, 10±1sec	Solder bath method
	350±5°C, 5sec max.	Soldering iron method
Applicable safety standard*2	Electrical Appliance and Material Safety Law ("DENAN"), IEC60065, UL6500, CSA C22.2	

*1 Pb free solder(Sn-3Ag-0.5Cu)

*2 However, this product is not recognized by each regulations.

Vertical Type TF Series

TF1813V-A(VERTICAL TYPE WITH TERMINAL BASE) TYPE SHAPES AND DIMENSIONS/CIRCUIT DIAGRAM

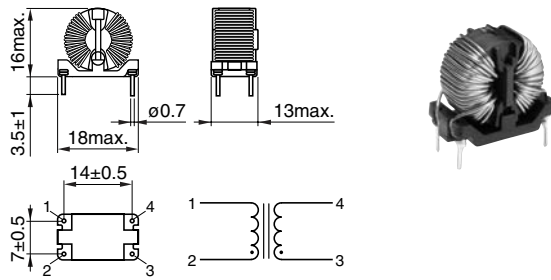

Weight: 5g typ.

Recommended hole diameter: $\phi 1.2$
Dimensions in mm

TYPICAL ELECTRICAL CHARACTERISTICS IMPEDANCE vs. FREQUENCY CHARACTERISTICS

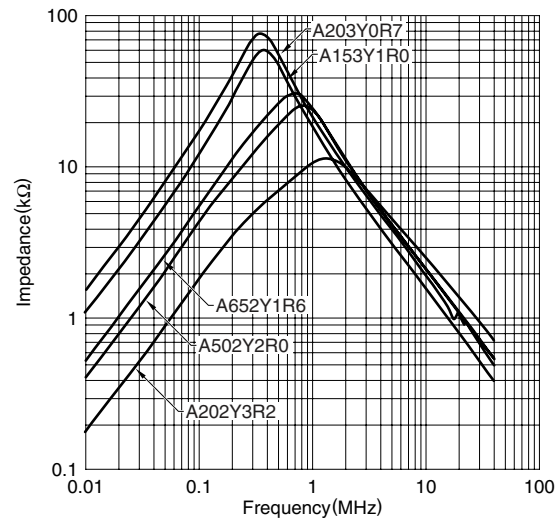

ELECTRICAL CHARACTERISTICS (STANDARD LINE UP)

Part No.	Inductance (mH)min.	DC resistance (Ω)max.	Rated current Iac(A)max.
TF1813V-A203Y0R7-01	20	0.73	0.7
TF1813V-A153Y1R0-01	15	0.44	1
TF1813V-A652Y1R6-01	6.5	0.19	1.6
TF1813V-A502Y2R0-01	5	0.14	2
TF1813V-A202Y3R2-01	2	0.065	3.2

- Measuring equipment of inductance value:
LCR meter(HP4261A, HP4263B or equivalent)[f=1kHz]

PACKAGING QUANTITIES

TF1813V-A	960pieces/box
-----------	---------------

RATINGS

Item	Standard value	Conditions
Rated voltage(V)	80 to 280	50Hz/60Hz
Dielectric withstanding voltage(V)	2000	Between each winding for 1 minute
Insulation resistance (M Ω)	100min.	Between each winding for DC.500V
Temperature rise($^{\circ}$ C)	45max.	With line resistance
Operating temperature range($^{\circ}$ C)	-20 to +120	Including self-temperature rise
Storage temperature range($^{\circ}$ C)	-20 to +85	
Resistance to soldering temperature*1	260 \pm 5 $^{\circ}$ C, 10 \pm 1sec	Solder bath method
Applicable safety standard*2	350 \pm 5 $^{\circ}$ C, 5sec max.	Soldering iron method
	Electrical Appliance and Material Safety Law ("DENAN"), IEC60065, UL6500, CSA C22.2	

*1 Pb free solder(Sn-3Ag-0.5Cu)

*2 However, this product is not recognized by each regulations.

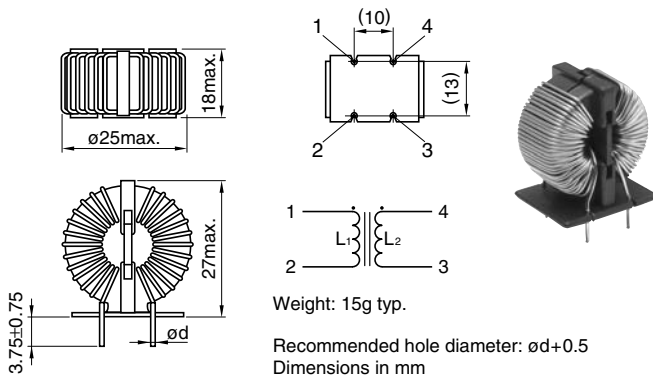
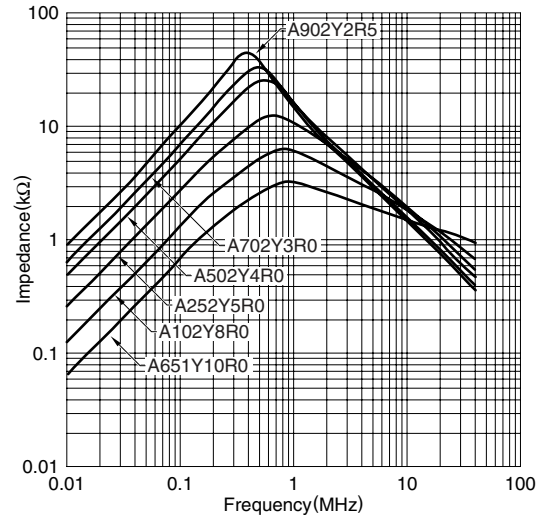
**TF2518V-A(VERTICAL TYPE WITH TERMINAL BASE) TYPE
SHAPES AND DIMENSIONS/CIRCUIT DIAGRAM**

**TYPICAL ELECTRICAL CHARACTERISTICS
IMPEDANCE vs. FREQUENCY CHARACTERISTICS**

**ELECTRICAL CHARACTERISTICS
(STANDARD LINE UP)**

Part No.	Inductance (mH)min.	DC resistance (Ω)max.	Rated current lac(A)max.	ϕd (mm)
TF2518V-A902Y2R5-01	9	0.12	2.5	0.6
TF2518V-A702Y3R0-01	7	0.095	3	0.65
TF2518V-A502Y4R0-01	5	0.075	4	0.7
TF2518V-A252Y5R0-01	2.5	0.05	5	0.75
TF2518V-A102Y8R0-01	1	0.025	8	0.95
TF2518V-A651Y10R0-01	0.65	0.02	10	1

- Measuring equipment of inductance value:
LCR meter(HP4261A, HP4263B or equivalent)[f]=1kHz]

PACKAGING QUANTITIES

TF2518V-A	560pieces/box
-----------	---------------

RATINGS

Item	Standard value	Conditions
Rated voltage(V)	80 to 280	50Hz/60Hz
Dielectric withstanding voltage(V)	2000	Between each winding for 1 minute
Insulation resistance (M Ω)	100min.	Between each winding for DC.500V
Temperature rise($^{\circ}$ C)	45max.	With line resistance
Operating temperature range($^{\circ}$ C)	-20 to +120	Including self-temperature rise
Storage temperature range($^{\circ}$ C)	-20 to +85	
Resistance to soldering temperature*1	260 \pm 5 $^{\circ}$ C, 10 \pm 1sec	Solder bath method
Applicable safety standard*2	350 \pm 5 $^{\circ}$ C, 5sec max.	Soldering iron method
	Electrical Appliance and Material Safety Law ("DENAN"), IEC60065, UL6500, CSA C22.2	

*1 Pb free solder(Sn-3Ag-0.5Cu)

*2 However, this product is not recognized by each regulations.

TF2721V-A(VERTICAL TYPE WITH TERMINAL BASE) TYPE SHAPES AND DIMENSIONS/CIRCUIT DIAGRAM

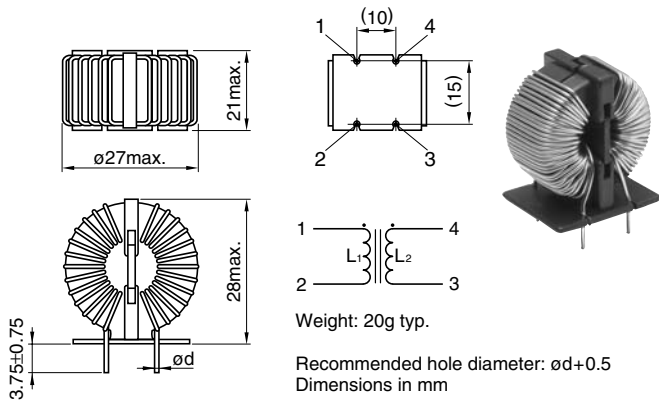

ELECTRICAL CHARACTERISTICS (STANDARD LINE UP)

Part No.	Inductance (mH)min.	DC resistance (mΩ)max.	Rated current Iac(A)max.	ød (mm)
TF2721V-A133Y2R5-01	13	130	2.5	0.65
TF2721V-A103Y3R0-01	10	90	3	0.7
TF2721V-A652Y4R0-01	6.5	60	4	0.8
TF2721V-A422Y5R0-01	4.2	40	5	0.9
TF2721V-A152Y8R0-01	1.5	20	8	1
TF2721V-A102Y10R0-01	1	11	10	1.2

- Measuring equipment of inductance value:
LCR meter(HP4261A, HP4263B or equivalent)[f=1kHz]

PACKAGING QUANTITIES

TF2721V-A	460pieces/box
-----------	---------------

TYPICAL ELECTRICAL CHARACTERISTICS IMPEDANCE vs. FREQUENCY CHARACTERISTICS

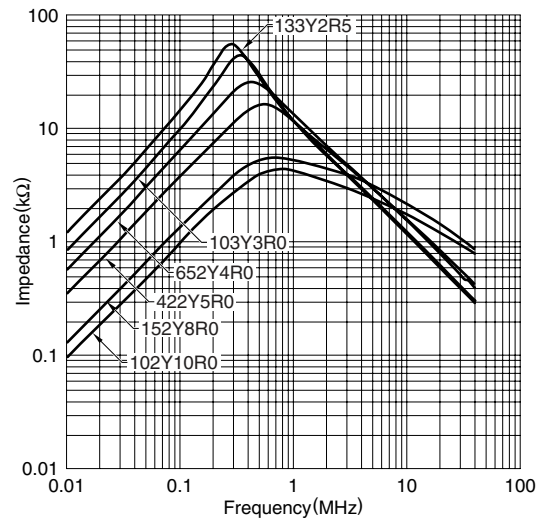

RATINGS

Item	Standard value	Conditions
Rated voltage(V)	80 to 280	50Hz/60Hz
Dielectric withstanding voltage(V)	2000	Between each winding for 1 minute
Insulation resistance (MΩ)	100min.	Between each winding for DC.500V
Temperature rise(°C)	45max.	With line resistance
Operating temperature range(°C)	-20 to +120	Including self-temperature rise
Storage temperature range(°C)	-20 to +85	
Resistance to soldering temperature*1	260±5°C, 10±1sec	Solder bath method
Applicable safety standard*2	350±5°C, 5sec max.	Soldering iron method
	Electrical Appliance and Material Safety Law ("DENAN"), IEC60065, UL6500, CSA C22.2	

*1 Pb free solder(Sn-3Ag-0.5Cu)

*2 However, this product is not recognized by each regulations.

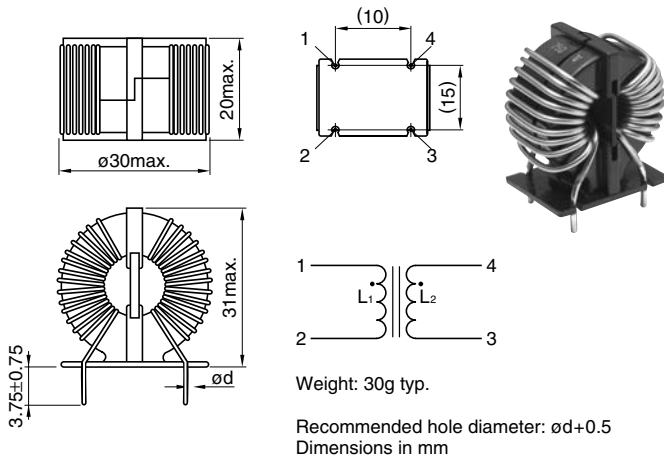
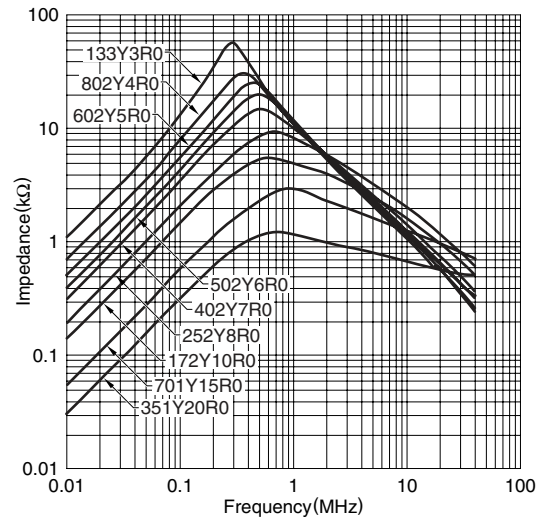
**TF3020V-A(VERTICAL TYPE WITH TERMINAL BASE) TYPE
SHAPES AND DIMENSIONS/CIRCUIT DIAGRAM**

**TYPICAL ELECTRICAL CHARACTERISTICS
IMPEDANCE vs. FREQUENCY CHARACTERISTICS**

**ELECTRICAL CHARACTERISTICS
(STANDARD LINE UP)**

Part No.	Inductance (mH)min.	DC resistance (Ω)max.	Rated current lac(A)max.	ϕd (mm)
TF3020V-A133Y3R0-01	13	0.1	3	0.75
TF3020V-A802Y4R0-01	8	0.07	4	0.8
TF3020V-A602Y5R0-01	6	0.05	5	0.9
TF3020V-A502Y6R0-01	5	0.04	6	0.95
TF3020V-A402Y7R0-01	4	0.035	7	1
TF3020V-A252Y8R0-01	2.5	0.025	8	1.1
TF3020V-A172Y10R0-01	1.7	0.015	10	1.3
TF3020V-A701Y15R0-01	0.7	0.007	15	1.6
TF3020V-A351Y20R0-01	0.35	0.005	20	1.7

- Measuring equipment of inductance value:
LCR meter(HP4261A, HP4263B or equivalent)[f=1kHz]

PACKAGING QUANTITIES

TF3020V-A	440pieces/box
-----------	---------------

RATINGS

Item	Standard value	Conditions
Rated voltage(V)	80 to 280	50Hz/60Hz
Dielectric withstanding voltage(V)	2000	Between each winding for 1 minute
Insulation resistance (M Ω)	100min.	Between each winding for DC.500V
Temperature rise($^{\circ}$ C)	45max.	With line resistance
Operating temperature range($^{\circ}$ C)	-20 to +120	Including self-temperature rise
Storage temperature range($^{\circ}$ C)	-20 to +85	
Resistance to soldering temperature*1	260 \pm 5 $^{\circ}$ C, 10 \pm 1sec	Solder bath method
	350 \pm 5 $^{\circ}$ C, 5sec max.	Soldering iron method

*1 Pb free solder(Sn-3Ag-0.5Cu)

*2 However, this product is not recognized by each regulations.

TF3525V-A(VERTICAL TYPE WITH TERMINAL BASE) TYPE SHAPES AND DIMENSIONS/CIRCUIT DIAGRAM

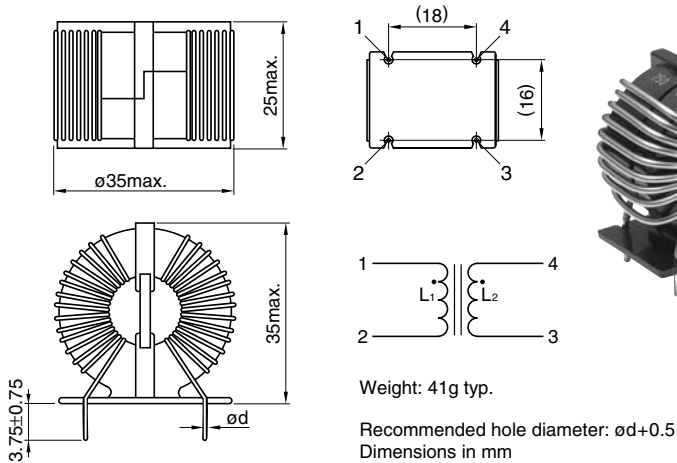

TYPICAL ELECTRICAL CHARACTERISTICS IMPEDANCE vs. FREQUENCY CHARACTERISTICS

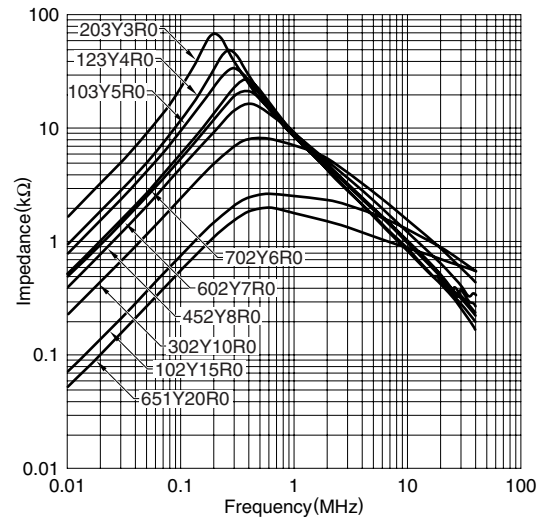

ELECTRICAL CHARACTERISTICS (STANDARD LINE UP)

Part No.	Inductance (mH)min.	DC resistance (mΩ)max.	Rated current Iac(A)max.	ϕd (mm)
TF3525V-A203Y3R0-01	20	130	3	0.75
TF3525V-A123Y4R0-01	12	75	4	0.85
TF3525V-A103Y5R0-01	10	55	5	0.95
TF3525V-A702Y6R0-01	7	45	6	1
TF3525V-A602Y7R0-01	6	35	7	1.1
TF3525V-A452Y8R0-01	4.5	25	8	1.2
TF3525V-A302Y10R0-01	3	18	10	1.3
TF3525V-A102Y15R0-01	1	6	15	1.7
TF3525V-A651Y20R0-01	0.65	4	20	1.8

- Measuring equipment of inductance value:
LCR meter(HP4261A, HP4263B or equivalent)[f=1kHz]

PACKAGING QUANTITIES

TF3525V-A	240pieces/box
-----------	---------------

RATINGS

Item	Standard value	Conditions
Rated voltage(V)	80 to 280	50Hz/60Hz
Dielectric withstanding voltage(V)	2000	Between each winding for 1 minute
Insulation resistance (MΩ)	100min.	Between each winding for DC.500V
Temperature rise(°C)	45max.	With line resistance
Operating temperature range(°C)	-20 to +120	Including self-temperature rise
Storage temperature range(°C)	-20 to +85	
Resistance to soldering temperature*1	260±5°C, 10±1sec	Solder bath method
	350±5°C, 5sec max.	Soldering iron method
Applicable safety standard*2	Electrical Appliance and Material Safety Law ("DENAN"), IEC60065, UL6500, CSA C22.2	

*1 Pb free solder(Sn-3Ag-0.5Cu)

*2 However, this product is not recognized by each regulations.

Vertical Type (For High Frequency) TF Series

FEATURES

- This series is designed to reduce stray capacity between windings by using a single-layer coil construction on Ni-Zn ferrite cores, which offer excellent high frequency characteristics.
- This series provides excellent noise suppression for high frequency ranges including the FM band.

TF2628V-1H(VERTICAL TYPE WITH TERMINAL BASE) TYPE SHAPES AND DIMENSIONS/CIRCUIT DIAGRAM

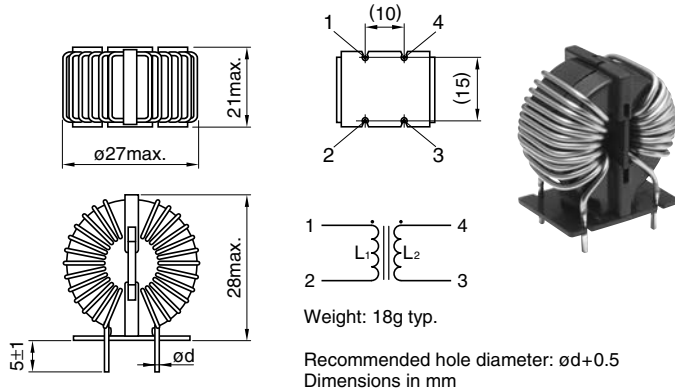

TYPICAL ELECTRICAL CHARACTERISTICS IMPEDANCE vs. FREQUENCY CHARACTERISTICS

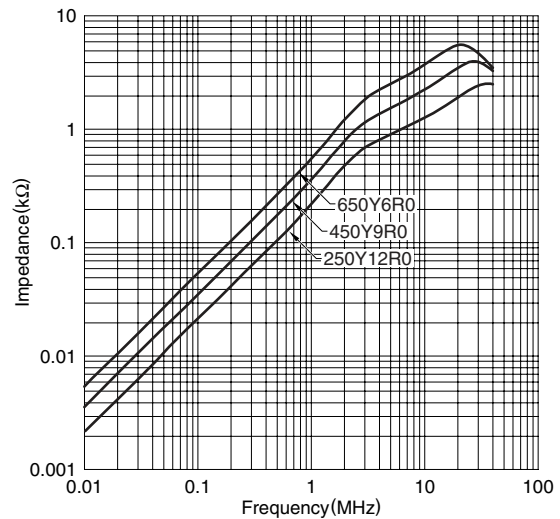

ELECTRICAL CHARACTERISTICS (STANDARD LINE UP)

Part No.	Inductance (μH)min.	DC resistance ($\text{m}\Omega$)max.	Rated current Iac (A)max.	ϕd (mm)
TF2628V-650Y6R0-1H	65	20	6	0.8
TF2628V-450Y9R0-1H	45	12	9	1
TF2628V-250Y12R0-1H	25	9	12	1.2

- Measuring equipment of inductance value:
LCR meter(HP4261A, HP4263B or equivalent)[$f=10\text{kHz}$]

PACKAGING QUANTITIES

TF2628V-1H	700pieces/box
------------	---------------

RATINGS

Item	Standard value	Conditions
Rated voltage(V)	80 to 280	50Hz/60Hz
Dielectric withstanding voltage(V)	2000	Between each winding for 1 minute
Insulation resistance ($\text{M}\Omega$)	100min.	Between each winding for DC.500V
Temperature rise($^{\circ}\text{C}$)	45max.	With line resistance
Operating temperature range($^{\circ}\text{C}$)	-20 to +120	Including self-temperature rise
Storage temperature range($^{\circ}\text{C}$)	-20 to +85	
Resistance to soldering temperature*1	260 \pm 5 $^{\circ}\text{C}$, 10 \pm 1sec	Solder bath method
Applicable safety standard*2	350 \pm 5 $^{\circ}\text{C}$, 5sec max.	Soldering iron method
	Electrical Appliance and Material Safety Law ("DENAN"), IEC60065, UL6500, CSA C22.2	

*1 Pb free solder(Sn-3Ag-0.5Cu)

*2 However, this product is not recognized by each regulations.

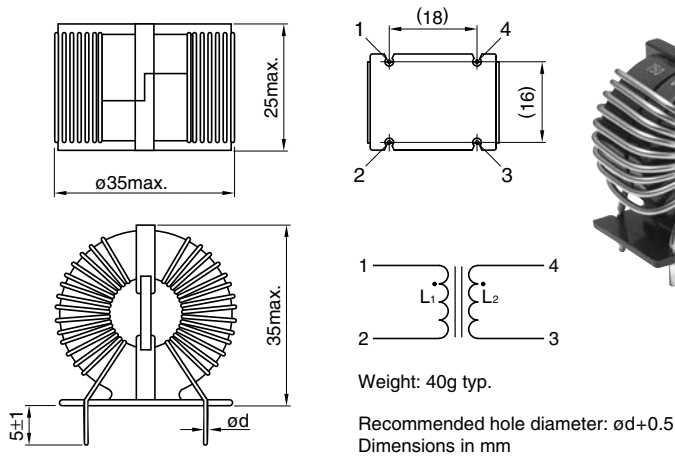
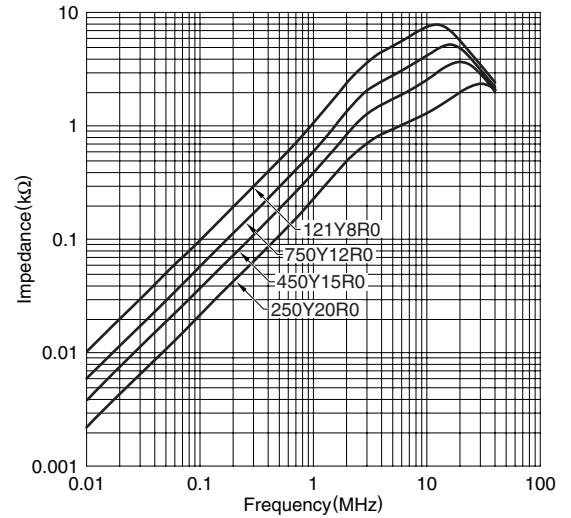
**TF3524V-1H(VERTICAL TYPE WITH TERMINAL BASE) TYPE
SHAPES AND DIMENSIONS/CIRCUIT DIAGRAM**

**TYPICAL ELECTRICAL CHARACTERISTICS
IMPEDANCE vs. FREQUENCY CHARACTERISTICS**

**ELECTRICAL CHARACTERISTICS
(STANDARD LINE UP)**

Part No.	Inductance (μH)min.	DC resistance ($\text{m}\Omega$)max.	Rated current Iac(A)max.	ϕd (mm)
TF3524V-121Y8R0-1H	120	20	8	1
TF3524V-750Y12R0-1H	75	10	12	1.3
TF3524V-450Y15R0-1H	45	7	15	1.6
TF3524V-250Y20R0-1H	25	5	20	1.8

- Measuring equipment of inductance value:
LCR meter(HP4261A, HP4263B or equivalent)[f=10kHz]

PACKAGING QUANTITIES

TF3524V-1H	320pieces/box
------------	---------------

RATINGS

Item	Standard value	Conditions
Rated voltage(V)	80 to 280	50Hz/60Hz
Dielectric withstanding voltage(V)	2000	Between each winding for 1 minute
Insulation resistance ($\text{M}\Omega$)	100min.	Between each winding for DC.500V
Temperature rise($^{\circ}\text{C}$)	45max.	With line resistance
Operating temperature range($^{\circ}\text{C}$)	-20 to +120	Including self-temperature rise
Storage temperature range($^{\circ}\text{C}$)	-20 to +85	
Resistance to soldering temperature*1	260 \pm 5 $^{\circ}\text{C}$, 10 \pm 1sec	Solder bath method
	350 \pm 5 $^{\circ}\text{C}$, 5sec max.	Soldering iron method
Applicable safety standard*2	Electrical Appliance and Material Safety Law ("DENAN"), IEC60065, UL6500, CSA C22.2	

*1 Pb free solder(Sn-3Ag-0.5Cu)

*2 However, this product is not recognized by each regulations.