

NanoRF Edge Launch Connector

HIGH FREQUENCY CONTACTS SUPPORT HIGH PERFORMANCE
UP TO 70 GHZ



High frequency contacts support high performance up to 70 Ghz



Description

TE Connectivity (TE) has introduced the NanoRF Edge Launch connector. This product offers higher density and ruggedness over SMPM and SMPS edge launch options, and integrates the RF above an optical interconnect (with TE's hybrid RF/optical modules). This product offers higher density and ruggedness over SMPM and SMPS edge launch options, and the technology can be leveraged to support SOSA aligned NanoRF connector modules.

ROBUST AND SPACE SAVING

- NanoRF contact plug in module is terminated to the pc board, eliminating the need for cables

EASIER TERMINATION

- Bullet adapter takes up tolerance between edge launch termination and mating face and decreases the mating force required for stacked boards

VERSATILE

- Contact and module design is configurable for different sizes and contact counts

INDUSTRY STANDARDS

- Supports VITA 67.3 interface for VPX industry standard implementations with SOSA compliance to support plug-in computing modules

MARKETS SERVED

- Military
- Radar

APPLICATIONS

- RF switches
- Tuners
- Software defined radios (RF devices for use in embedded computing systems)

ELECTRICAL

- **Frequency range** of 2 MHz to 40 GHz and 1.5:1 over the frequency range of 40 GHz to 85 GHz.
- VSWR of 1.4:1 over the frequency range of 2 MHz to 40 GHz and 1.5:1 over the frequency range of 40 GHz to 67 GHz.
- **Crosstalk:** Frequency Range 3 GHz to 27 GHz and can achieve 100 db of crosstalk
- **Insertion Loss:** Not be greater than $0.12 * \sqrt{f}$ dB, where f is in GHz. Maximum insertion loss at 20 GHz = 0.5367 dB.
- Meets VITA 72 Shock and Vibration
- Meets VITA 67 Environmental Requirement

Test report to 108-163-006-1 Spec

STANDARDS AND SPECIFICATIONS

- **EIA-364:** Electrical Connector/Socket Test Procedures Including Environmental Classifications
- **ANSI/VITA 67.3:** Coaxial Interconnect on VPX, Spring-Loaded Contact on Backplane
- **ANSI/VITA 48.1:** Mechanical Specification for Microcomputers Using RED1 Air Cooling
- **ANSI/VITA 46.0:** VPX Baseline Standard
- **ANSI/VITA 65.0-2019:** OpenVPX System Standard
- **ANSI/VITA 65.1-2019:** OpenVPX System Standard – Profile Tables
- **MIL-STD-810H:** Environmental Engineering Considerations and Laboratory Tests, Jan 2019





NanoRF Edge Launch Connector

Eliminates Cables in the Plug-In Module

Direct Board Termination

- NanoRF contact on plug-in module directly terminated to the board
- Contacts fixed in module frame mounted to board
- Upper rows (if needed) use cabling







	Part Number	Description
	2332714-2	Daughtercard Assembly, Edge Launch, 67.3 (for separable solution w/bullet)
	2332709-2	Backplane Module, RF, 67.3C, Edge Launch

With Bullet Adapter

- NanoRF contacts tightly positioned in module
- Bullets take up tolerance between edge launch terminations and NanoRF mating face
- Ideal for stacked boards. Contact row heights in VITA 65.1 support stacked boards
- This approach is implemented today with 67.3 SMPM



	Part Number	Description
	2332714-2	Daughtercard Assembly, Edge Launch, 67.3
	2337098-1	SMPS Edge Launch: 6 Position
	2331630-1	Adapter, SMPS, Bullet
	2332709-2	Backplane Module, RF, 67.3C, Edge Launch

NanoRF Edge Launch Kit

- 6 bullets
- SMPS solder bar
- 6 SMPS to NanoRF adapters
- Daughtercard module



Part Number	Description
2393429-1	Stainless Steel Kit
2393429-2	Aluminum Kit

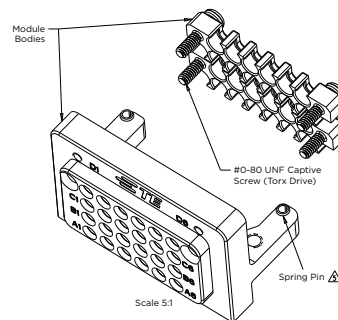
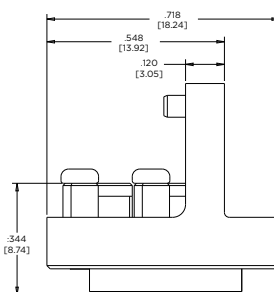
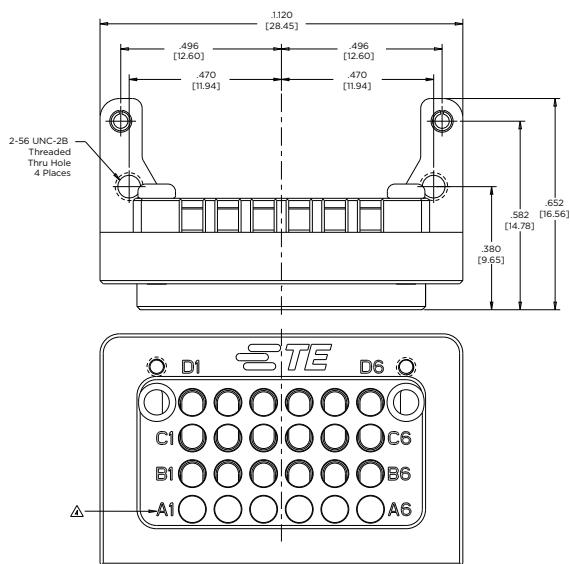

MATERIAL

Module Bodies: Aluminum Alloy
Screws and Spring Pins: Stainless Steel

FINISH

Module Bodies: Clear Chromate Conversion Coating
Screws and Spring Pins: Passivated

NanoRF Edge Launch Connector

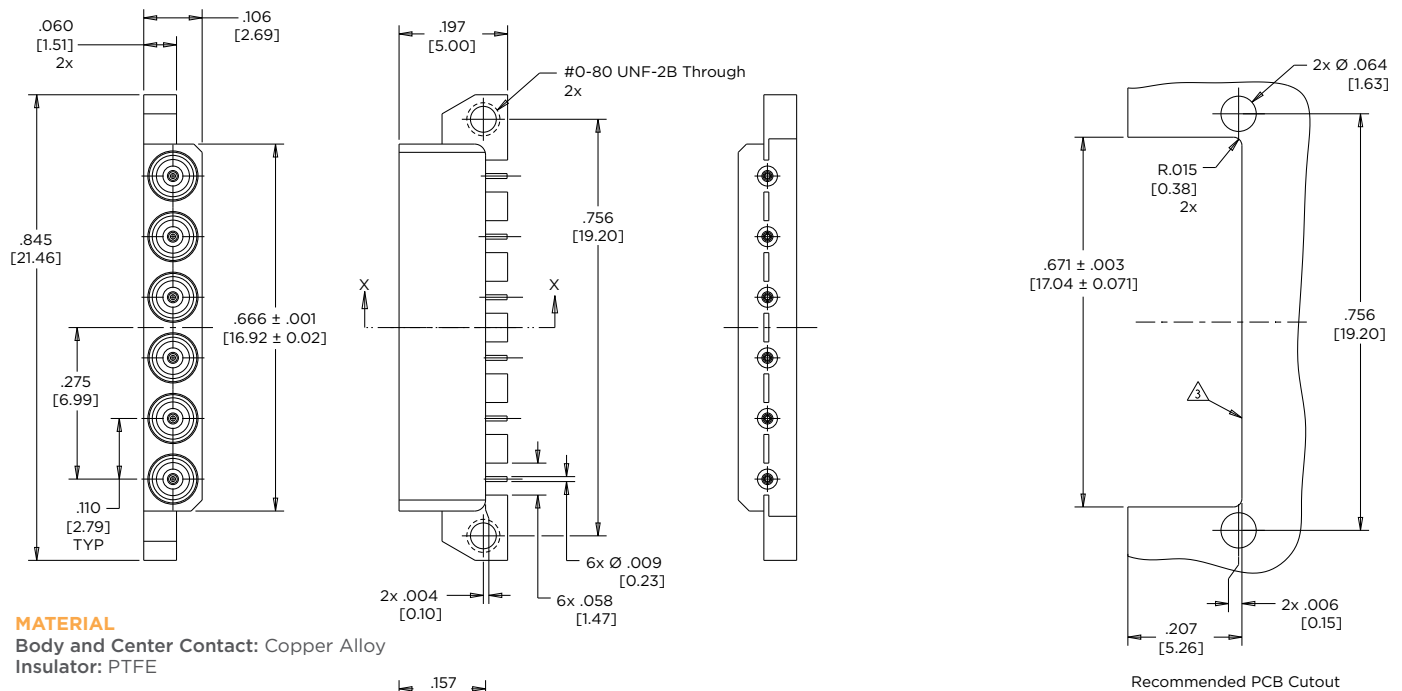

MATERIAL

Body and Center Contact: Copper Alloy
Insulator: PTFE

FINISH

Front Body: 50-90 µin.
 Gold Plate over Nickel
Center Contact: 35-70 µin.
 Gold Plate over Nickel
Rear Body: 3-15 µin.
 Gold Plate over Nickel

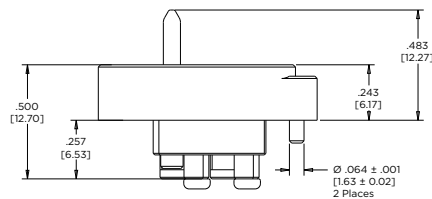
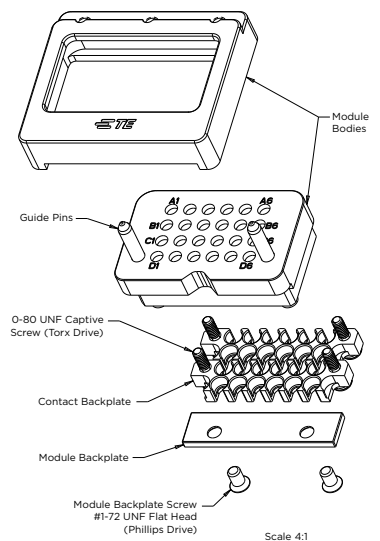
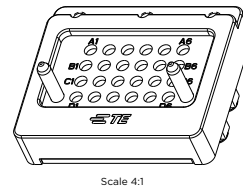
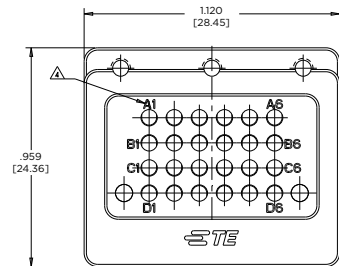
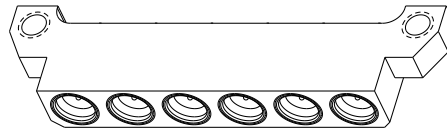
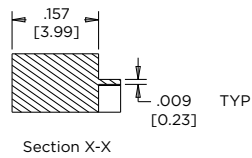

MATERIAL

Module Bodies and Backplates: Aluminum Alloy
Guide Pin: Stainless Steel, per UNS S30300
Screws: 300 Series Stainless Steel

FINISH

Module Bodies: Clear Chromate Conversion Coating
Screws and Guide Pin: Passivated

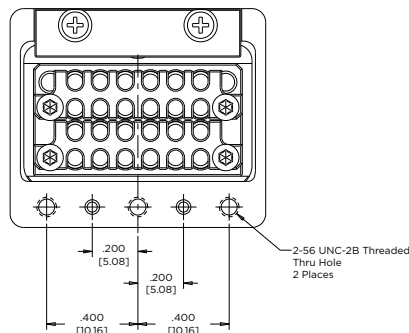

NanoRF Edge Launch Connector

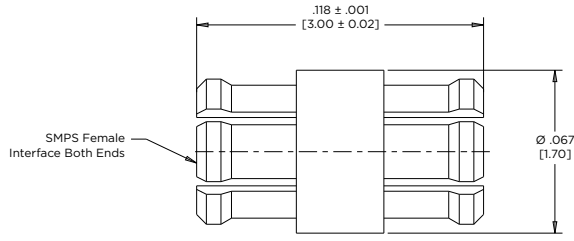

MATERIAL

Body and Center Contact: Copper Alloy
Insulator: PTFE

FINISH

Body and Center Contact: Gold Plate over Nickel

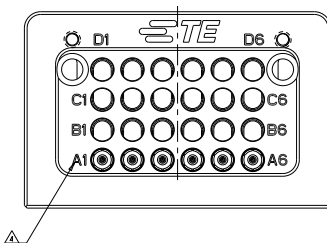
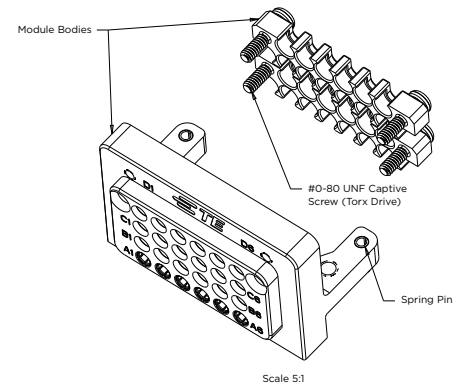
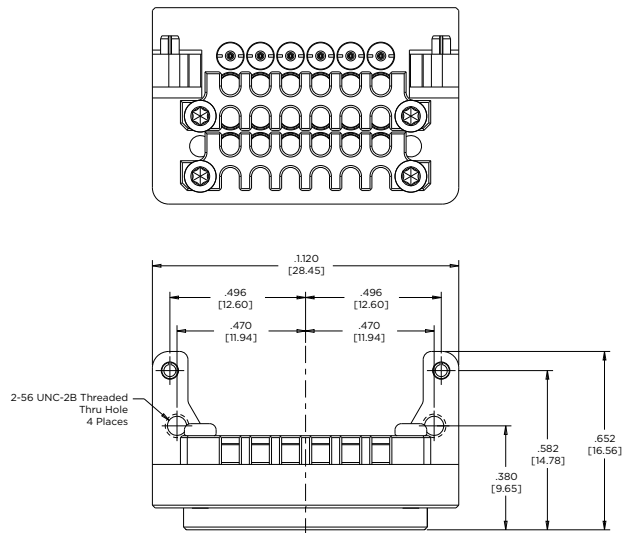

MATERIAL

Module Bodies: Aluminum Alloy
Screws and Spring Pins: Stainless Steel
Contact Bodies and Pin: Copper Alloy
Insulator: PTFE

FINISH

Module Bodies: Clear Chromate Conversion Coating
Screws and Spring Pins: Passivated
Front Contact Body and Pin: 50-90 μm . Gold Plate over Nickel
Rear Contact Body: 3-15 μm . Gold Plate over Nickel

Compatibility is Standard



NanoRF Backplane Modules



NanoRF Backplane Contacts



Mezzanine Connectors

Empower Engineers to Solve Problems, Moving the World Forward.

AMP | AGASTAT | CII | DEUTSCH | DRI | HARTMAN | KILOVAC
MICRODOT | NANONICS | POLAMCO | Raychem | Rochester | SEACON

CONNECT WITH US

We make it easy to connect with our experts and are ready to provide all the support you need. Visit te.com/support to chat with a Product Information Specialist.

QUALITY STARTS WITH THE RIGHT APPLICATION TOOLING

Creating a quality crimp connection is essential to delivering high performance and reliability in extreme environments. From low to high volume wire processing, TE has you covered with a full range of application tooling and a global field service team.

- [View all application tooling](#)
- [Connect with our experts to find the right tool for your application](#)

te.com/nanoRF-Edge

AMP, AGASTAT, CII, DEUTSCH, DRI, HARTMAN, KILOVAC, MICRODOT, NANONICS, POLAMCO, Raychem, Rochester, SEACON, TE, TE Connectivity, and TE connectivity (logo) are trademarks owned or licensed by TE Connectivity. All other logos, products and/or company names referred to herein might be trademarks of their respective owners.

The information given herein, including drawings, illustrations and schematics which are intended for illustration purposes only, is believed to be reliable. However, TE Connectivity makes no warranties as to its accuracy or completeness and disclaims any liability in connection with its use. TE Connectivity's obligations shall only be as set forth in TE Connectivity's Standard Terms and Conditions of Sale for this product and in no case will TE Connectivity be liable for any incidental, indirect or consequential damages arising out of the sale, resale, use or misuse of the product. Users of TE Connectivity products should make their own evaluation to determine the suitability of each such product for the specific application.

© 2021 TE Connectivity All Rights Reserved.

2385918-1 06/21

NanoRF Edge Launch Connector

TE Connectivity
Aerospace, Defense & Marine
2900 Fulling Mill Road
Middletown, PA 17057