

PART NUMBER	REVISION	DESCRIPTION	FEED TYPE
2150420-1	B	FINE CRIMP HEIGHT ADJUST	MECHANICAL
2150420-2	B	FINE CRIMP HEIGHT ADJUST	PNEUMATIC
7-2150420-1	B	MECHANICAL AND CRIMP TOOLING KIT	MECHANICAL
7-2150420-2	B	PNEUMATIC AND CRIMP TOOLING KIT	PNEUMATIC
7-2150420-7	A	CRIMP TOOLING KIT	-

ATLANTIC VERSION TERMINATOR INTERFACE ADAPTER

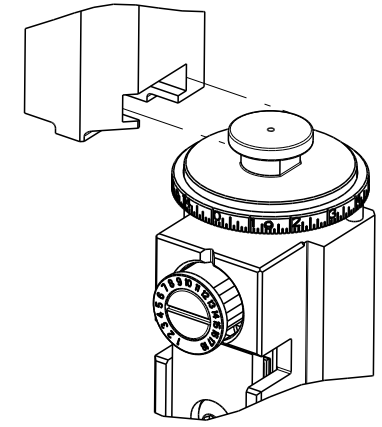

APPLICATOR DATA		
CRIMP	SIZE	TYPE
WIRE	2.29 mm [.090]	F
INSUL	4.57 mm [.180]	F

APPLICATOR INSTRUCTIONS 408-35043

TERMINAL DATA: TE TERMINAL		TE CRIMP SPECIFICATION
TERMINAL NAME: RECEPTACLE FASTON .187 SERIES		
WIRE STRIP LENGTH		INSULATION DIAMETER RANGE
3.75-3.76 mm [.148-.148 IN]		∅2.79-4.06 mm [.110-.160 IN]
TERMINAL APPLICATION SPECIFICATION	114-35000	
TERMINALS APPLIED		
TE TERMINAL	TE TERMINAL	TE TERMINAL
1217149-1		

WIRE SIZE	CRIMP HEIGHT mm [INCH]	CRIMP HEIGHT REFERENCE SETTING
14 AWG	1.88 +/- 0.05 [.074 +/- .002]	4.6
16 AWG	1.60 +/- 0.05 [.063 +/- .002]	7.7
18 AWG	1.42 +/- 0.05 [.056 +/- .002]	9.5

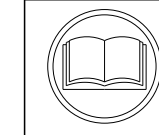

- 1 RECOMMENDED SPARE PARTS
- 2 REFER TO SUPPLIED INSTRUCTION SHEET FOR CLEANING, LUBRICATION AND STORAGE OF APPLICATOR.
- 3 APPLY PART NUMBER 2-23419-6 LOCTITE TO THREADS OF ITEM 242. APPLY PART NUMBER 1-23419-5 LOCTITE TO THREADS OF ITEM 180.
- 4 CRIMP HEIGHT REFERENCE SETTING WAS THE SETTING USED WHEN THE APPLICATOR WAS QUALIFIED AT THE FACTORY. ADJUSTMENT MAY BE NECESSARY WHEN RUNNING APPLICATOR IN THE FIELD.
- 5. UNLESS SPECIFIED OTHERWISE TORQUE VALUES SHALL BE USED PER DOCUMENT, 101-35000.

ATLANTIC VERSION
Shown on sheets 1 of 4 & 2 of 4
(Pacific version shown on sheets 3 of 4 & 4 of 4)

LOC	DIST	REVISIONS					
		P	LTN	DESCRIPTION	DATE	OWN	APVD
A	66	1		DEVELOPMENT	19FEB2014	YY	UG
		A		RELEASED	11MAR2014	YY	UG
		B		ECR-20-003067	02MAR2020	TB	TE

-	1	-	1	-	2119641-1	FEED CAM, AIR FEED	248
-	1	1	1	1	2119082-9	CAM, SNAIL, INSULATION ADJUSTMENT	244
-	1	1	1	1	2079764-1	WASHER, WAVE SPRING, CREST-TO-CREST	243
3	-	1	1	1	2119083-1	RETAINER, INSULATION DIAL	242
-	-	1	-	1	2119580-1	MECHANICAL FEED ASSEMBLY	239
-	1	-	1	-	2844940-3	AIR FEED MODULE	238
-	1	1	1	1	1-18028-0	WASHER, FLAT, REG M8	192
3	-	1	1	1	1752354-5	STANDOFF, HOLD-DOWN	180
-	1	1	1	1	6-993111-6	PIN, SLOTTED SPRING 3.0 X 14.0	177
-	1	1	1	1	8-22280-7	SPRING, COMPRESSION	176
-	1	1	1	1	1752353-2	GUIDE PIN, HOLDDOWN	175
-	1	1	1	1	1901680-2	GUIDE PIN, HOLDDOWN	174
-	REF	REF	REF	REF	994970-2	COUNTER, MAGNETIC	164
-	1	1	1	1	455888-5	SPACER, CRIMPER	82
-	1	1	1	1	1803607-4	DOCUMENTATION PACKAGE	71
-	2	2	2	2	2-18032-2	SCR, SET, FLT PNT, M3 X 10.0	70
-	1	1	1	1	2119740-1	TAG, IDENTIFICATION	67
-	2	2	2	2	2168078-1	SCREW, DRIVE, RH, RoHS, 2 x .188	66
-	1	1	1	1	1901681-5	HOLDDOWN, TERMINAL	65
-	2	2	2	2	2168400-5	SHCS, LOW HEAD, RoHS, M4 X 20	64
-	1	1	1	1	2168083-2	SCR, SKT HD CAP, RoHS, M4 X 8.0	60
-	1	1	1	1	5-18022-5	SCR, HEX HD CAP, M4 X 6.0	59
-	-	1	-	1	2063961-1	FEED FINGER	58
-	3	3	3	3	2168400-4	SHCS, LOW HEAD, RoHS, M4 X 8	57
-	2	2	2	2	2168083-2	SCR, SKT HD CAP, RoHS, M4 X 8.0	56
-	2	2	2	2	5018030-1	NUT, HEX, REG, RoHS, M3	54
-	2	2	2	2	986965-8	NUT, LOCK, HEX, TORQUE (M4)	53
-	1	1	1	1	1-5018030-0	NUT, HEX, REG, RoHS, M3.5	52
-	1	-	1	-	2063961-9	FEED FINGER	51
-	1	2	1	2	18023-9	SCR, SKT HD CAP M4 X 6.0	49
-	-	1	-	1	2119652-1	FEED CAM, PRE FEED	48
-	-	1	-	1	2119653-1	FEED CAM, POST FEED	47
-	1	1	1	1	2119655-5	APPLICATOR BASIC ASSEMBLY, EF	46
-	1	1	1	1	1803517-1	RAM ASSEMBLY, EF ATLANTIC	44
-	1	1	1	1	1803602-1	SCR, BHSC, RoHS (M8 X 25)	41
-	7	7	7	7	1-18028-2	WASHER, FLAT, REG M4	33
-	2	2	2	2	2168083-9	SCR, SKT HD CAP, RoHS, M4 X 20	31
-	2	2	2	2	2168083-2	SCR, SKT HD CAP, RoHS, M4 X 8.0	29
-	1	1	1	1	240639-1	STRIPPER (MACHINING)	27
-	2	2	2	2	1-2168083-5	SCR, SKT HD CAP, RoHS, M4 X 30	25
-	1	1	1	1	1-1752371-2	PLATE, STRIP GUIDE	24
-	1	1	1	1	240825-1	PLATE, STRIP HOLD DOWN	23
-	2	2	2	2	2-22281-3	SPRING, COMPRESSION	22
-	1	1	1	1	1803292-4	DRAG	20
-	2	2	2	2	1901259-5	GUIDE, LOWER STRIP	18
-	4	4	4	4	1-2079383-1	SCR, BHSC, RoHS (M6 X 12)	17
1	-	1	1	1	240644-5	PLATE, REAR SHEAR	11
-	-	-	-	-	-	-	10
1	-	1	1	1	4-690495-7	PLATE, FRONT SHEAR	9
1	1	2	2	1	4-1803000-4	ANVIL, COMBINATION, END FEED	8
1	-	1	1	1	2217206-4	BLADE, SLUG	7
-	-	-	-	-	-	-	6
-	1	1	1	1	240641-5	SPACER	5
-	1	1	1	1	238011-2	BLOCK, CRIMPER SPACER	4
1	1	2	2	1	2119582-3	CRIMPER, INSULATION F PREMIUM	3
-	1	1	1	1	455888-3	SPACER, CRIMPER	2
1	1	2	2	1	4-456406-7	CRIMPER, WIRE PREMIUM	1
-	77	72	71	2	-1	PART NO	ITEM NO

DIMENSIONS:		TOLERANCES UNLESS OTHERWISE SPECIFIED:		OWN	CHK	DATE	NAME	
mm	0 PLC	±		Y. YIN	G. BAILEY	19FEB2014	TE Connectivity	
	1 PLC	±					Harrisburg, PA 17105-3608	
	2 PLC	±					Ocean End Feed	
	3 PLC	±					Applicator	
	4 PLC	±					-	
	ANGLES	±					-	
	FINISH	±					-	
MATERIAL				APVD	U. GUO	19FEB2014	SIZE	CAGE CODE
				APPLICATION SPEC			A1	00779
							DRAWING NO	2150420
				WEIGHT			SCALE	1:1
							SHEET	1 of 4
							REV	B

LOC	DIST	REV	DESCRIPTION	DATE	OWN	APVD
A	66		SEE SHEET 1			

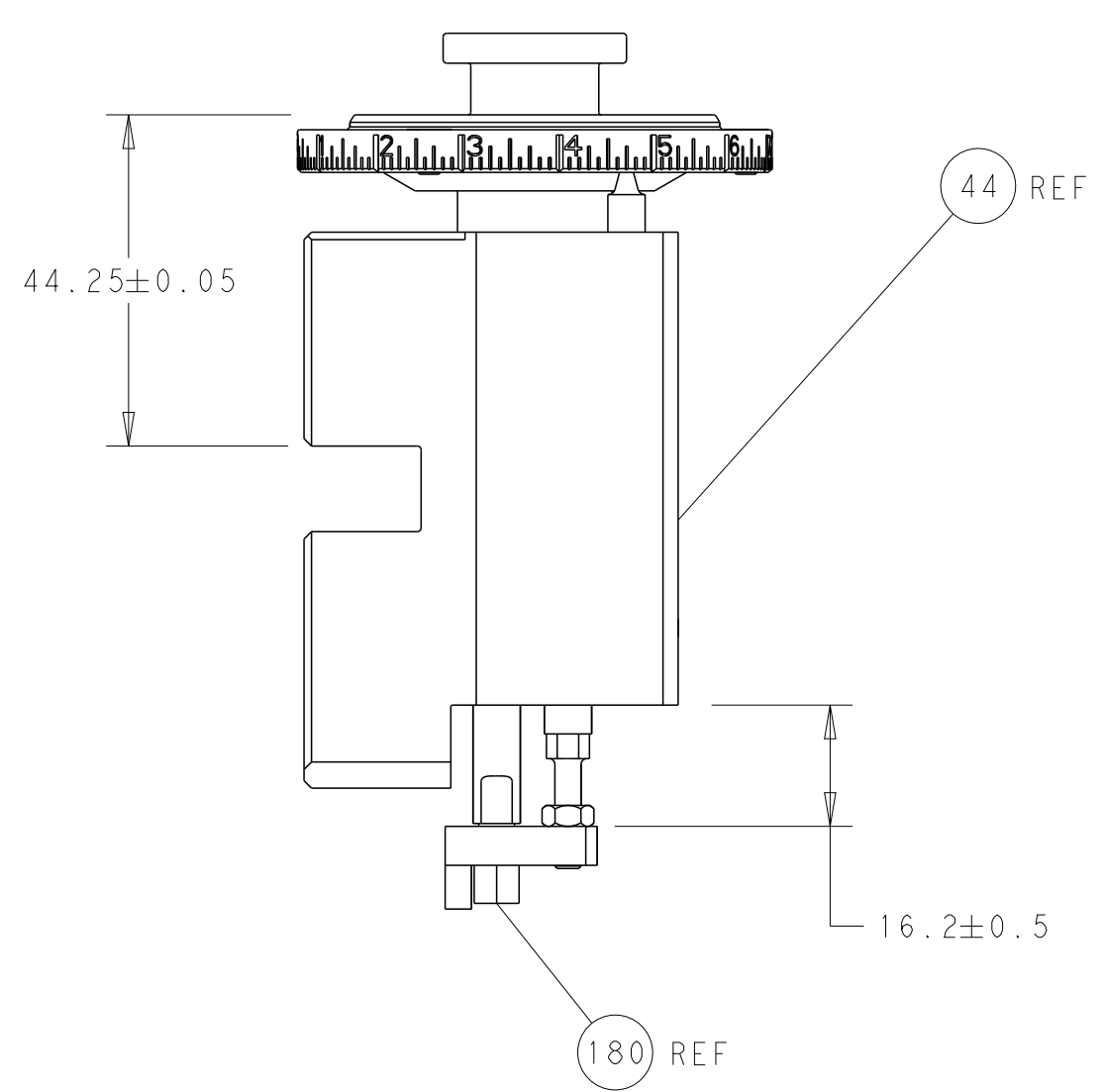

RAM AND HOLDDOWN SET-UP

FEED TYPE
MECHANICAL

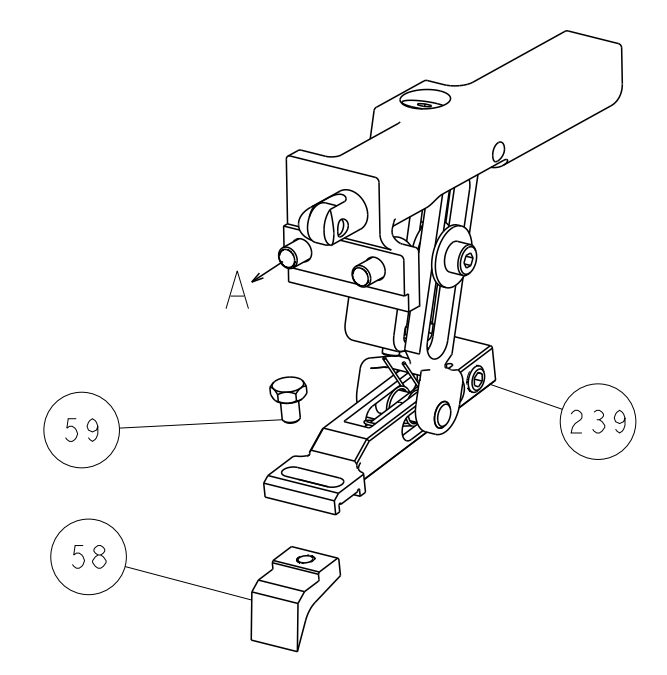

PNEUMATIC

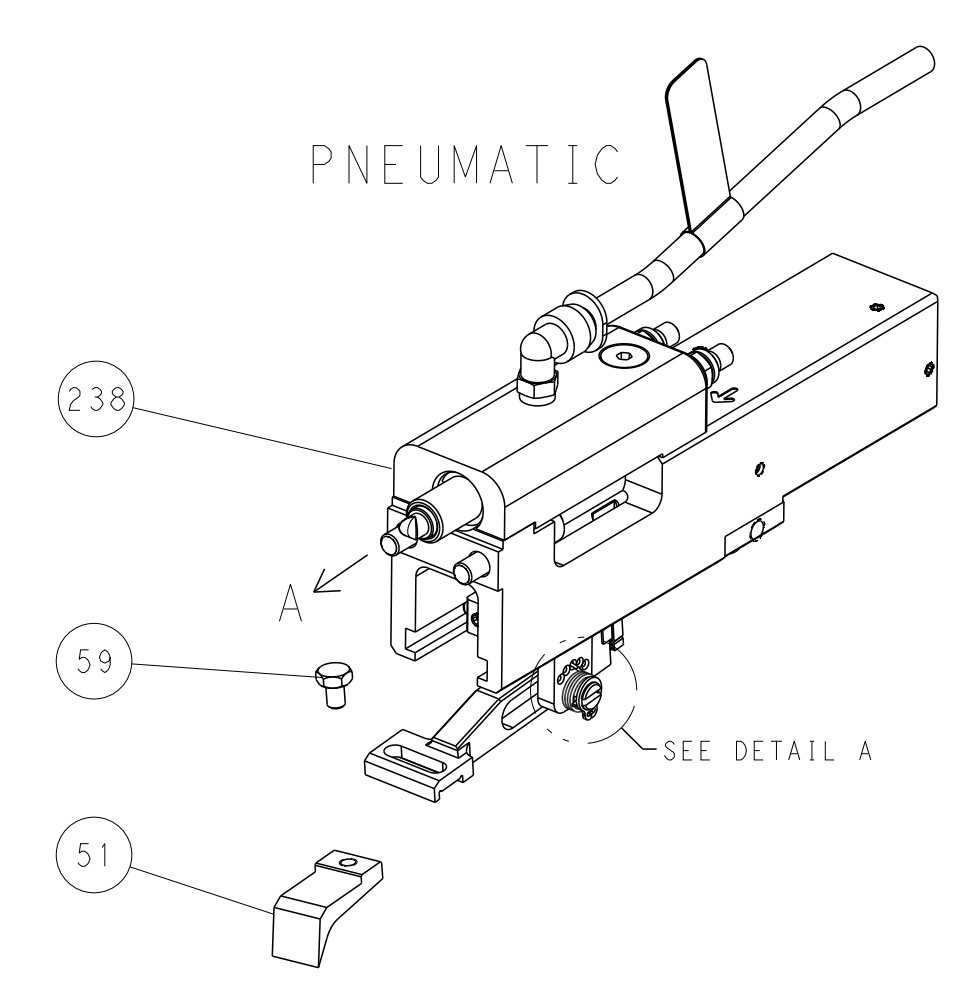

FEED SPRING
SETTING POSITION

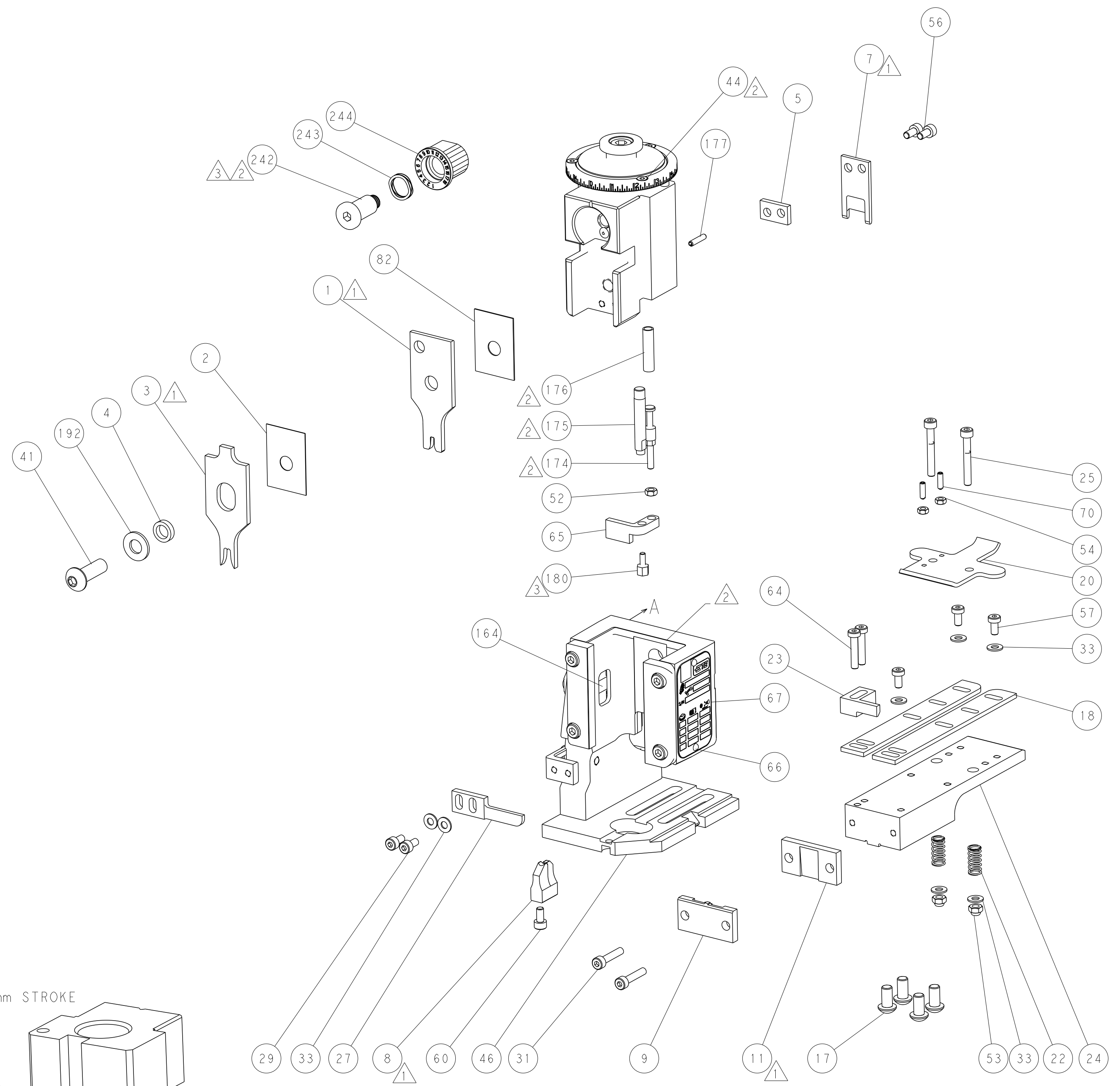
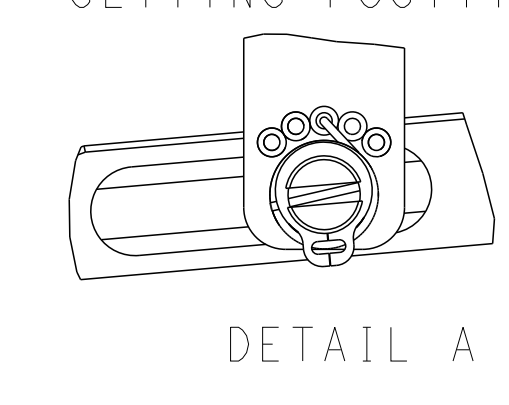

CAM POSITIONS

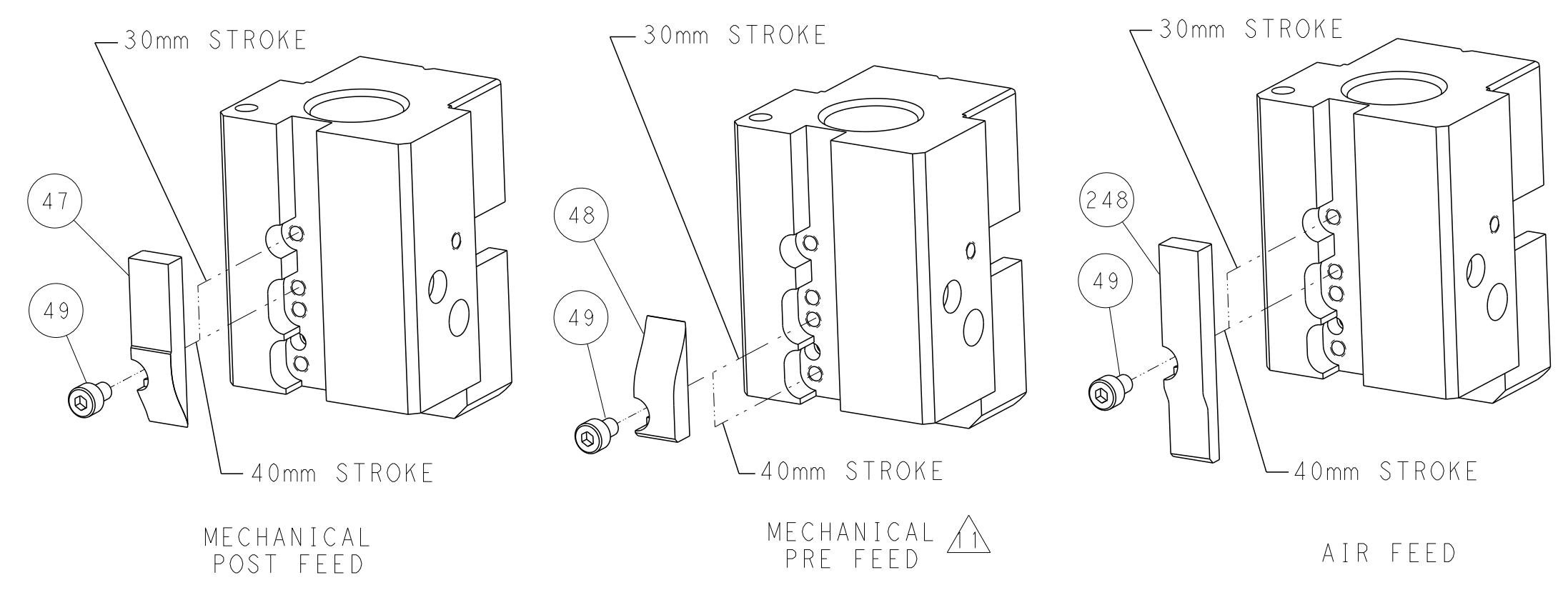

ATLANTIC VERSION
 Shown on sheets 1 of 4 & 2 of 4
 (Pacific version shown on sheets 3 of 4 & 4 of 4)

DIMENSIONS: mm 		TOLERANCES UNLESS OTHERWISE SPECIFIED: 0 PLC ± 1 PLC ± 2 PLC ± 3 PLC ± 4 PLC ± ANGLES ± FINISH		DWN Y. YIN 19FEB2014 CHK G. BAILEY 19FEB2014 APVD H. GUO 19FEB2014 PRODUCT SPEC APPLICATION SPEC WEIGHT Customer Accessible Production Drawing		NAME Ocean End Feed Applicator SIZE CAGE CODE DRAWING NO A1 00779 C=2150420 SCALE 1:1 SHEET 2 OF 4 REV B		RESTRICTED TO -	
-----------------------	--	---	--	--	--	--	--	--------------------	--

PART NUMBER	REVISION	DESCRIPTION	FEED TYPE
2-2150420-1	B	FINE CRIMP HEIGHT ADJUST	MECHANICAL
2-2150420-2	B	FINE CRIMP HEIGHT ADJUST	PNEUMATIC
7-2150420-7	A	CRIMP TOOLING KIT	-

PACIFIC VERSION TERMINATOR
INTERFACE ADAPTER

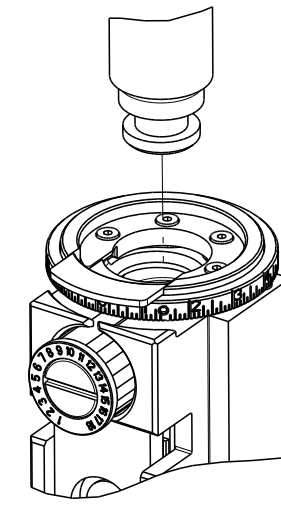

APPLICATOR DATA		
CRIMP	SIZE	TYPE
WIRE	2.29 mm (.090)	F
INSUL	4.57 mm (.180)	F
APPLICATOR INSTRUCTIONS 408-35043		

TERMINAL DATA: TE TERMINAL		TE CRIMP SPECIFICATION	
TERMINAL NAME: RECEPTACLE FASTON .187 SERIES			
WIRE STRIP LENGTH		INSULATION DIAMETER RANGE	
3.75-3.76 mm (.148-.148 IN)		2.79-4.06 mm (.110-.160 IN)	
TERMINAL APPLICATION SPECIFICATION	114-35000	-	-
TERMINALS APPLIED			
TE TERMINAL	TE TERMINAL	TE TERMINAL	TE TERMINAL
1217149-1			

WIRE SIZE	CRIMP HEIGHT mm [INCH]	CRIMP HEIGHT REFERENCE SETTING
14 AWG	1.88 +/- 0.05 [.074 +/- .002]	4.6
16 AWG	1.60 +/- 0.05 [.063 +/- .002]	7.7
18 AWG	1.42 +/- 0.05 [.056 +/- .002]	9.5



- RECOMMENDED SPARE PARTS
- REFER TO SUPPLIED INSTRUCTION SHEET FOR CLEANING, LUBRICATION AND STORAGE OF APPLICATOR.
- APPLY PART NUMBER 2-23419-6 LOCTITE TO THREADS OF ITEM 242. APPLY PART NUMBER 1-23419-5 LOCTITE TO THREADS OF ITEM 180.
- CRIMP HEIGHT REFERENCE SETTING WAS THE SETTING USED WHEN THE APPLICATOR WAS QUALIFIED AT THE FACTORY. ADJUSTMENT MAY BE NECESSARY WHEN RUNNING APPLICATOR IN THE FIELD.
- UNLESS SPECIFIED OTHERWISE TORQUE VALUES SHALL BE USED PER DOCUMENT, 101-35000.

***WARNING**
ON INSTALLATION, SET WIRE DISC TO CRIMP HEIGHT REFERENCE SETTING FOR LARGEST WIRE SIZE. CRIMP HEIGHT REFERENCE SETTINGS GREATER THAN THE VALUE SHOWN MAY CAUSE DAMAGE TO THE CRIMP TOOLING. REFER TO THE INSTRUCTION SHEET FOR PROPER SETUP AND ADJUSTMENTS.

LOC	DIST	REVISIONS					
		P	LTN	DESCRIPTION	DATE	OWN	APVD
A	66	-	-	SEE SHEET 1	-	-	-

-	1	1	2119082-9	CAM, SNAIL, INSULATION ADJUSTMENT	244	
-	1	1	2079764-1	WASHER, WAVE SPRING, CREST-TO-CREST	243	
3	-	1	2119083-1	RETAINER, INSULATION DIAL	242	
-	-	1	2119580-1	MECHANICAL FEED ASSEMBLY	239	
-	1	-	2844940-3	AIR FEED MODULE	238	
-	1	1	1-18028-0	WASHER, FLAT, REG M8	192	
-	4	4	2079383-9	SCR, BHSC, RoHS (M6 X 20)	186	
3	-	1	1752354-5	STANDOFF, HOLD-DOWN	180	
-	1	1	6-993111-6	PIN, SLOTTED SPRING 3.0 X 14.0	177	
-	1	1	8-22280-7	SPRING, COMPRESSION	176	
-	1	1	1752353-2	GUIDE PIN, HOLDDOWN	175	
-	1	1	1901680-2	GUIDE PIN, HOLDDOWN	174	
-	REFREF	-	994970-2	COUNTER, MAGNETIC	164	
-	1	-	2119641-2	FEED CAM, AIR FEED	152	
-	1	1	2168083-8	SCR, SKT HD CAP, RoHS, M4 X 16	144	
-	-	1	2119653-2	FEED CAM, POST FEED	142	
-	1	1	2119655-6	APPLICATOR BASIC ASSEMBLY, EF	141	
-	1	1	1803518-1	RAM ASSEMBLY, EF PACIFIC	140	
-	1	1	455888-5	SPACER, CRIMPER	82	
-	1	1	1803607-4	DOCUMENTATION PACKAGE	71	
-	2	2	2-18032-2	SCR, SET, FLT PNT, M3 X 10.0	70	
-	1	1	2119740-1	TAG, IDENTIFICATION	67	
-	2	2	2168078-1	SCREW, DRIVE, RH, RoHS, 2 x .188	66	
-	1	1	1901681-5	HOLDDOWN, TERMINAL	65	
-	2	2	2168400-5	SHCS, LOW HEAD, RoHS, M4 X 20	64	
-	1	1	5-18022-5	SCR, HEX HD CAP, M4 X 6.0	59	
-	-	1	2063961-1	FEED FINGER	58	
-	3	3	2168400-4	SHCS, LOW HEAD, RoHS, M4 X 8	57	
-	2	2	2168083-2	SCR, SKT HD CAP, RoHS, M4 X 8.0	56	
-	2	2	5018030-1	NUT, HEX, REG, RoHS, M3	54	
-	2	2	986965-8	NUT, LOCK, HEX, TORQUE (M4)	53	
-	1	1	1-5018030-0	NUT, HEX, REG, RoHS, M3.5	52	
-	1	-	2063961-9	FEED FINGER	51	
-	1	2	18023-9	SCR, SKT HD CAP M4 X 6.0	49	
-	-	1	2119652-1	FEED CAM, PRE FEED	48	
-	1	1	1803602-1	SCR, BHSC, RoHS (M8 X 25)	41	
-	7	7	1-18028-2	WASHER, FLAT, REG M4	33	
-	2	2	2168083-9	SCR, SKT HD CAP, RoHS, M4 X 20	31	
-	2	2	2168083-2	SCR, SKT HD CAP, RoHS, M4 X 8.0	29	
-	1	1	240639-1	STRIPPER (MACHINING)	27	
-	2	2	1-2168083-5	SCR, SKT HD CAP, RoHS, M4 X 30	25	
-	1	1	1-1752371-2	PLATE, STRIP GUIDE	24	
-	1	1	240825-1	PLATE, STRIP HOLD DOWN	23	
-	2	2	2-22281-3	SPRING, COMPRESSION	22	
-	1	1	1803292-4	DRAG	20	
-	2	2	1901259-5	GUIDE, LOWER STRIP	18	
1	-	1	240644-5	PLATE, REAR SHEAR	11	
-	-	-	-	-	10	
1	-	1	4-690495-7	PLATE, FRONT SHEAR	9	
1	1	1	4-1803000-4	ANVIL, COMBINATION, END FEED	8	
1	-	1	2217206-4	BLADE, SLUG	7	
-	-	-	-	-	6	
-	1	1	240641-5	SPACER	5	
-	1	1	238011-2	BLOCK, CRIMPER SPACER	4	
1	1	1	2119582-3	CRIMPER, INSULATION F PREMIUM	3	
-	1	1	455888-3	SPACER, CRIMPER	2	
1	1	1	4-456406-7	CRIMPER, WIRE PREMIUM	1	
-	77	22	21	PART NO	DESCRIPTION	ITEM NO

PACIFIC VERSION
Shown on sheets 3 of 4 & 4 of 4
(Atlantic version shown on sheets 1 of 4 & 2 of 4)

DIMENSIONS:		TOLERANCES UNLESS OTHERWISE SPECIFIED:		DRAWN		DATE	
mm	0 PLC ±	1 PLC ±	2 PLC ±	Y. YIN	19FEB2014	CHK	19FEB2014
	3 PLC ±	4 PLC ±	ANGLES ±	G. BAILEY	19FEB2014	APVD	19FEB2014
MATERIAL	FINISH	WEIGHT	SCALE	TE Connectivity Harrisburg, PA 17105-3608 Ocean End Feed Applicator Customer Accessible Production Drawing SCALE 1:1 SHEET 3 OF 4 REV B			

LOC		DIST		REVISIONS			
A	66	P	LTM	DESCRIPTION	DATE	OWN	APVD
		-		SEE SHEET 1			

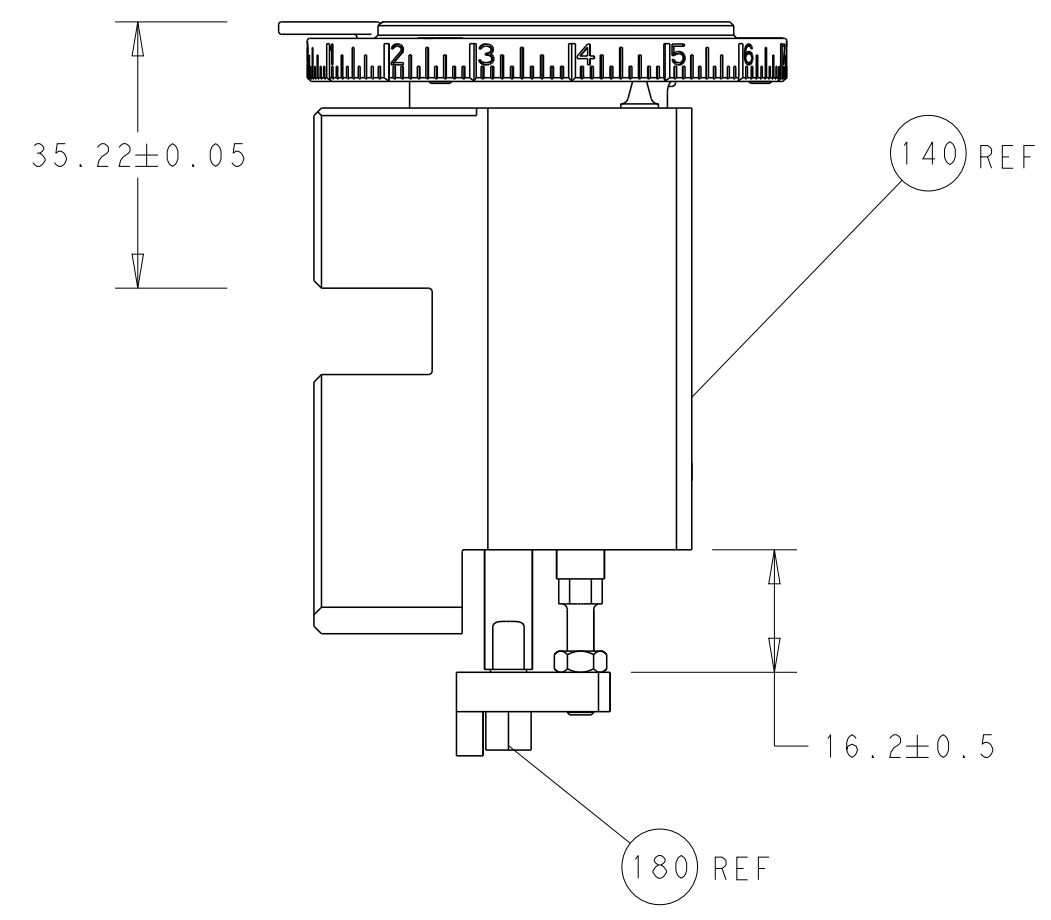

RAM AND HOLDDOWN SET-UP

FEED TYPE
MECHANICAL

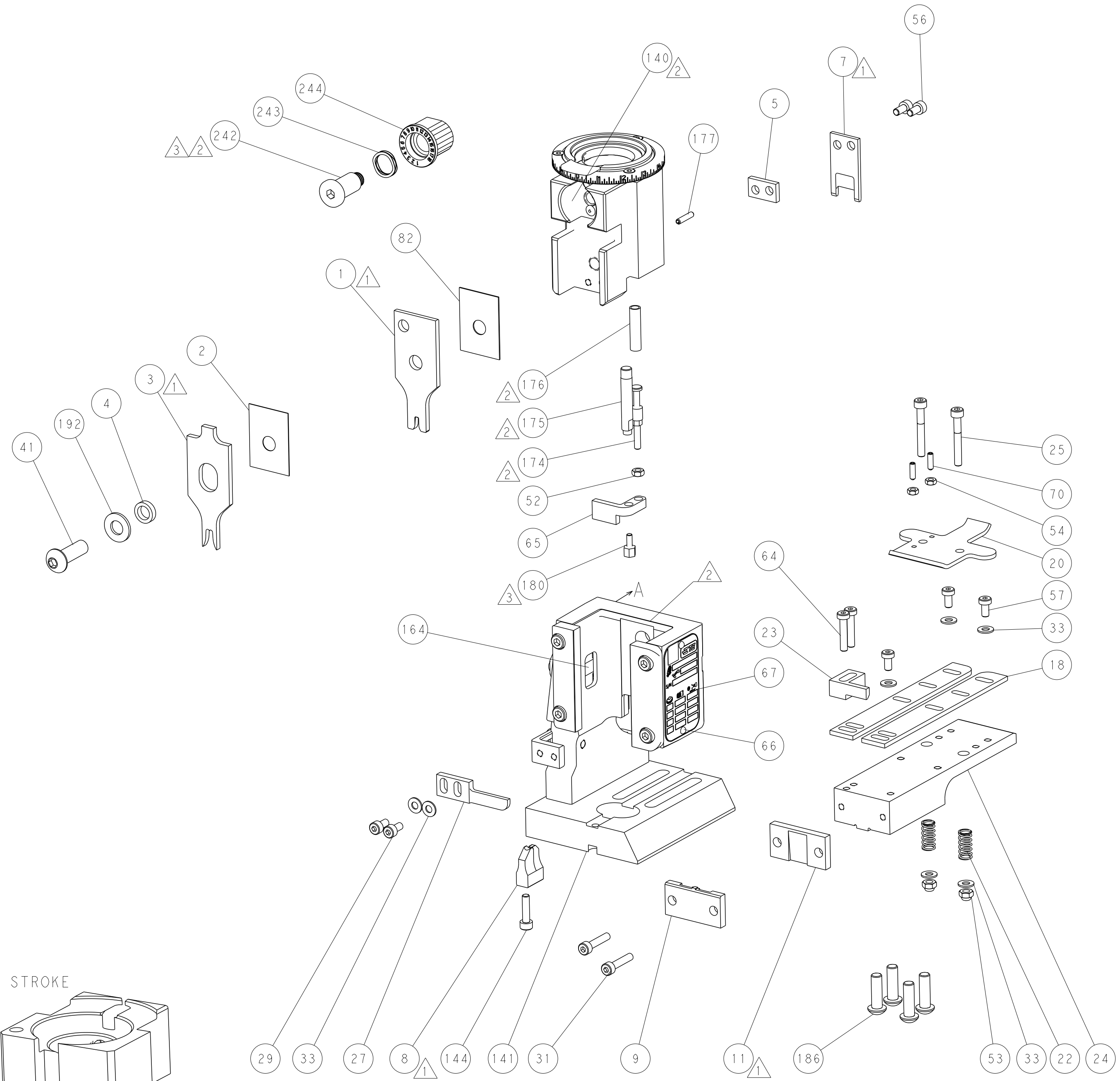
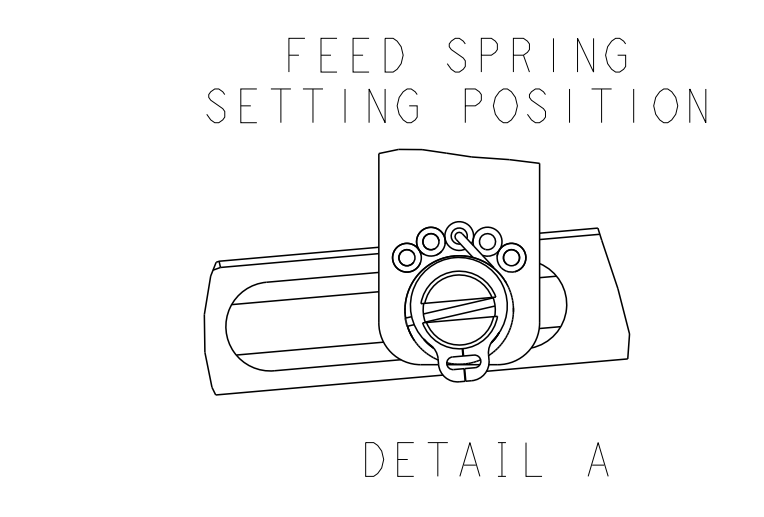
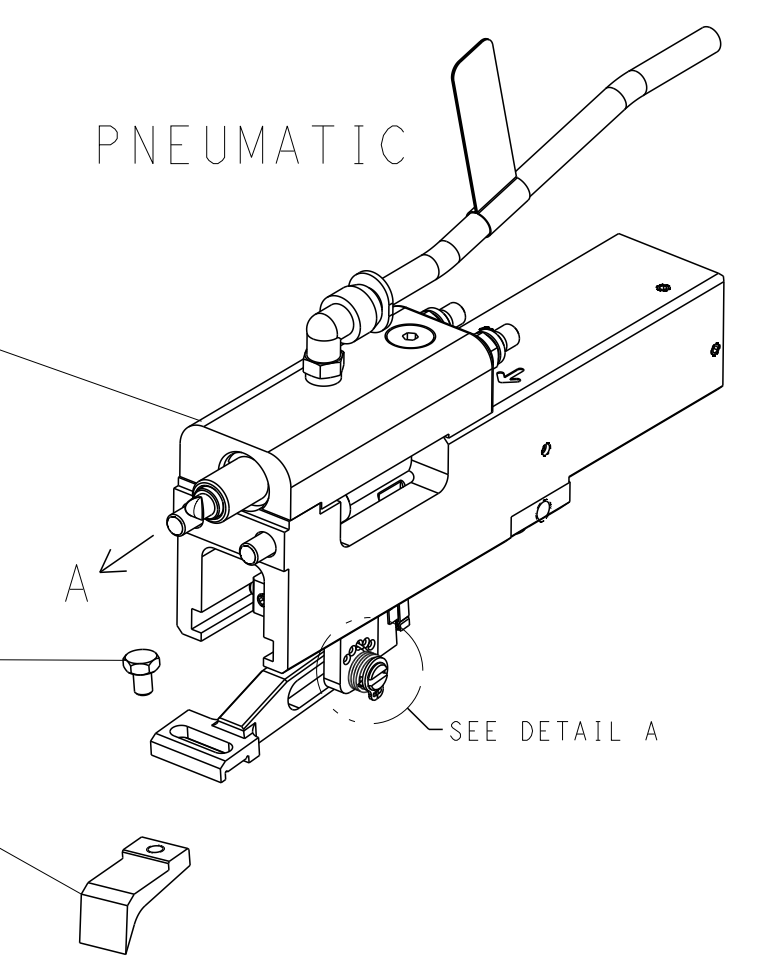
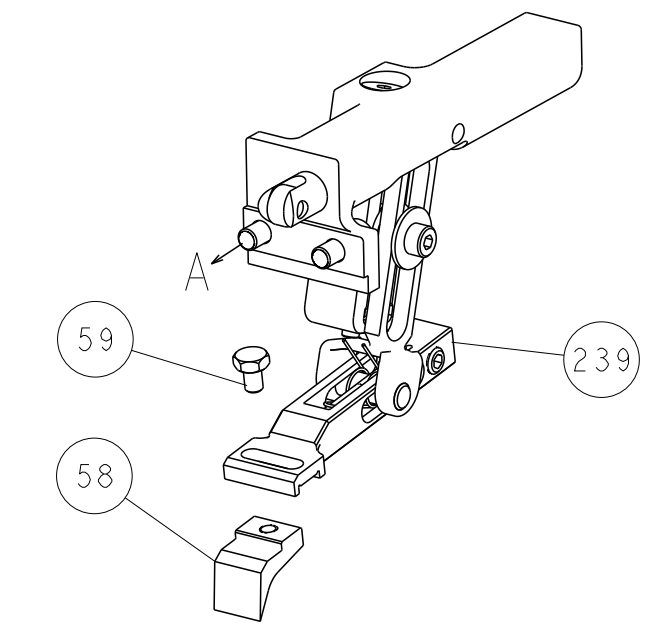

CAM POSITIONS

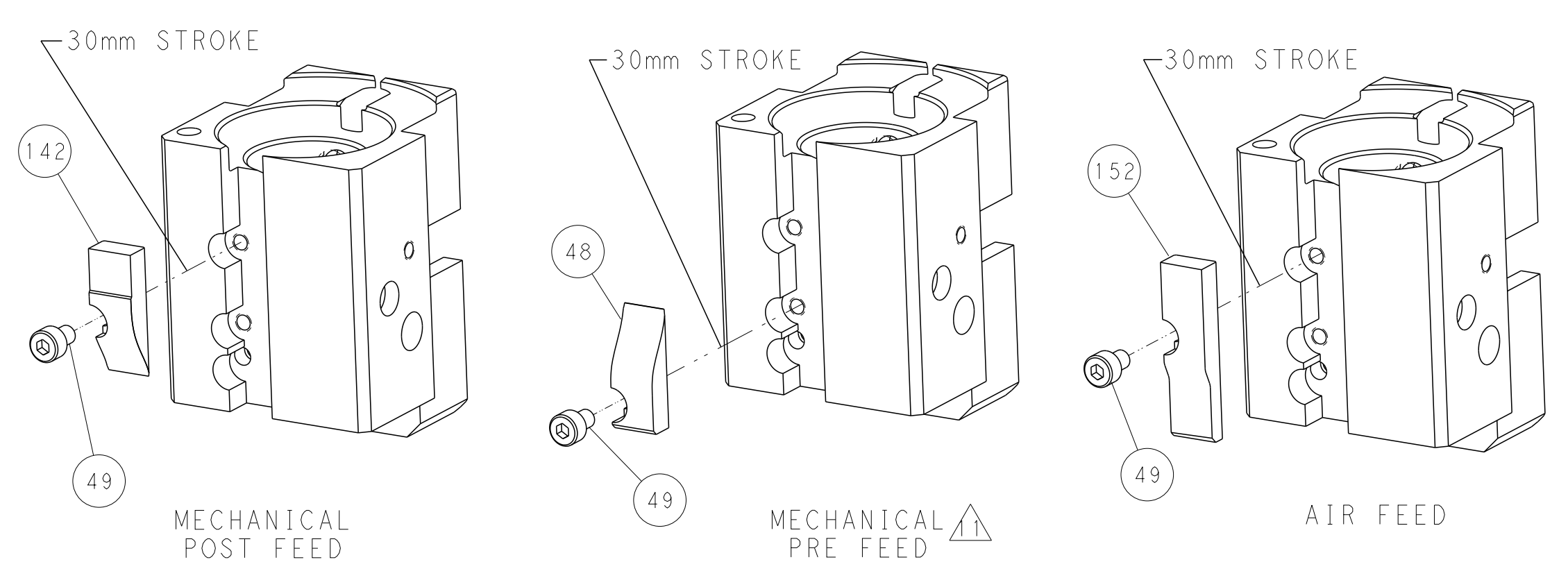

PACIFIC VERSION
 Shown on sheets 3 of 4 & 4 of 4
 (Atlantic version shown on sheets 1 of 4 & 2 of 4)

DIMENSIONS:		TOLERANCES UNLESS OTHERWISE SPECIFIED:		DWG: Y. YIN 19FEB2014		CHK: G. BAILEY 19FEB2014		NAME: STE TE Connectivity Harrisburg, PA 17105-3608	
mm	0 PLC ±	1 PLC ±	2 PLC ±	3 PLC ±	4 PLC ±	APVD: J. GUO 19FEB2014	PRODUCT SPEC	APPLICATION SPEC	RESTRICTED TO
MATERIAL:	FINISH:	WEIGHT:	SCALE: 1:1	SHEET: 4	OF: 4	REV: B	Customer Accessible Production Drawing		