

Switching Power Supply Type SPD 100W DIN rail mounting



- Installation on DIN Rail 7.5 or 15mm
- Short circuit protection
- PFC standard
- Power ready output on 24VDC
- LED indicator for DC power ON
- LED indicator for DC low
- Standard parallel function
- Very compact dimensions
- UL, cUL listed and TUV/CE approved
- Class I Div 2 Groups A, B, C, D approved

Product Description

This SPD is the most compact 100W power supply on the market. Relay output for “power ready” parallel function and PFC are included. Performances are unique with high efficiencies and the possibility of being used up to 70°C with a little derating.

Ordering Key

SP D 24 100 1

Model _____
 Mounting (D = Din rail) _____
 Output voltage _____
 Output power _____
 Input Type _____

Input type: 1= single phase

Approvals



Output Performances

MODEL NO.	INPUT VOLTAGE	OUTPUT WATTAGE	OUTPUT VOLTAGE	OUTPUT CURRENT	EFF. (min.)	EFF. (typ.)
Single Output Models						
SPD12100	90~264 VAC	100.8 WATTS	+12 VDC	8,4 A	82%	84%
SPD24100	90~264 VAC	100.8 WATTS	+24 VDC	4,2 A	84%	86%
SPD48100	90~264 VAC	100.8 WATTS	+48 VDC	2,1 A	86%	88%

Output Data

Line regulation	± 1%	Voltage fall time ($I_{o,nom}$ V_i nom)	150ms max
Load regulation		Rated continuous loading	
Non parallel model	±1%	12V Model	8.4A @ 12VDC/6.9A @ 14.5VDC
Parallel model	±5%	24V Model	4.2A @ 24VDC/3.5A @ 28.5VDC
Minimum load	0A	48V Model	2.1A @ 48VDC/1.8A @ 56VDC
Turn on time (full resistive load)		Reverse voltage	
V_i nom, I_o nom 12V/24V models with 7000 μ F CAP	1000ms	12V Model	VDC 18
V_i nom, I_o nom 48V models with 3500 μ F CAP	2000ms	24V Model	VDC 35
Transient recovery time	2ms	48V Model	VDC 63
Ripple and noise	50mVpp	Capacitor load	7000 μ F
Output voltage accuracy	±1%	Voltage rise time	
Temperature coefficient	±0.03%/°C	V_i nom I_o nom	150ms
Hold up time		V_i nom, I_o nom 12V/24V models with 7000 μ F CAP	500ms
$V_i=115$ VAC	15ms	48V model with 3500 μ F CAP	500ms
$V_i=230$ VAC	30ms		

Input Data

Rated input voltage	100 - 240VAC	Power dissipation (Vi : 230VAC, Io nom)	12V Model	18.5W
Voltage range			24V Model	15W
	AC		48V Model	14W
	DC			
Rated input current (Vi:90VAC, Io nom)	Typ.	2.4A	Frequency range	47-63Hz
Inrush current			Leakage current	
	Vi= 115VAC	30A	Input-Output	0.25mA
	Vi= 230VAC	60A	Input-FG	3.5mA

Controls and Protections

Overload	12V Model	14.5V to 17.4V	Over voltage protection	VDC	
	24V Model	30.0V to 33.0V		Min.	Max.
	48V Model	60.0V to 66.0V			
Input fuse	T3.15A/250VAC internal ¹⁾		12V Model	14.5	16.5
Output short circuit	Fold forward		24V Model	30	33
Power ready output threshold at start up	≥17.6-19.4VDC		48V Model	60	66
Electrical isolation	500VDC		Internal surge voltage protection (IEC 61000-4-5)	Varistor	
Contact rating at60VDC	0.3A				

¹⁾ Fuse not replaceable by user

General Data (@ nominal line, full load, 25°C)

Ambient temperature	-35°C to +71°C	Isolation resistance	input/output, @500VDC	100MΩ
Derating (>61°C to +71°C)	2.5%/C	Altitude during operation	5000m	
Ambient humidity	22 - 95% RH	Installation position	Vertical	
Storage temperature	-40°C to +85°C	MTB (Bellcore issue 6 @ 40°C, GB)		
Protection degree	IP20			
Cooling	Free air convection			
Pollution degree	2			
Switching frequency				
Vi nom, Io nom	45-60 kHz			
Isolation voltage		Case material	Plastic: PC, UL94-V0	
Input/output	3,000/4,242 VAC/VDC	Dimensions LxWxD mm(inch)	90(3.6) x 54(2.13) x 114(4.49)	
Input/FG	1,500/2,121 VAC/VDC	Weight	430 g	
Output/FG	500/710 VAC/VDC			

Norms and Standards

Vibration resistance	meet IEC 60068-2-6 (Mounting by rail: 10-500Hz, 2G, along X, Y, Z each Axis, 60 min for each Axis)	CE	EN 61000-6-3, EN 55022 Class B, EN 61000-3-2, EN 61000-3-3, EN 61000-6-2, EN 55024, EN 61000-4-2 Level 4, EN 61000-4-3 Level 3, EN 61000-4-4 Level 4, EN 61000-4-5 L-Level 3, L/N-FG Level 4, EN 61000-4-6 Level 3, EN 61000-4-8 Level 4, EN 61000-4-11, ENV 50204 Level 2, EN 61204-3
Shock resistance	meet IEC 60068-2-27 (15G, 11ms, 3 Axis, 6 faces, 3 times for each face)		
UL/cUL	UL508 listed, UL60950-1		
TUV	EN 60950-1, CB scheme EN 61558-1, EN 61558-2-17 (meet EN 60204)		
ISA	12.12.01 Class I Div 2 Groups A, B, C, D		

Block Diagram

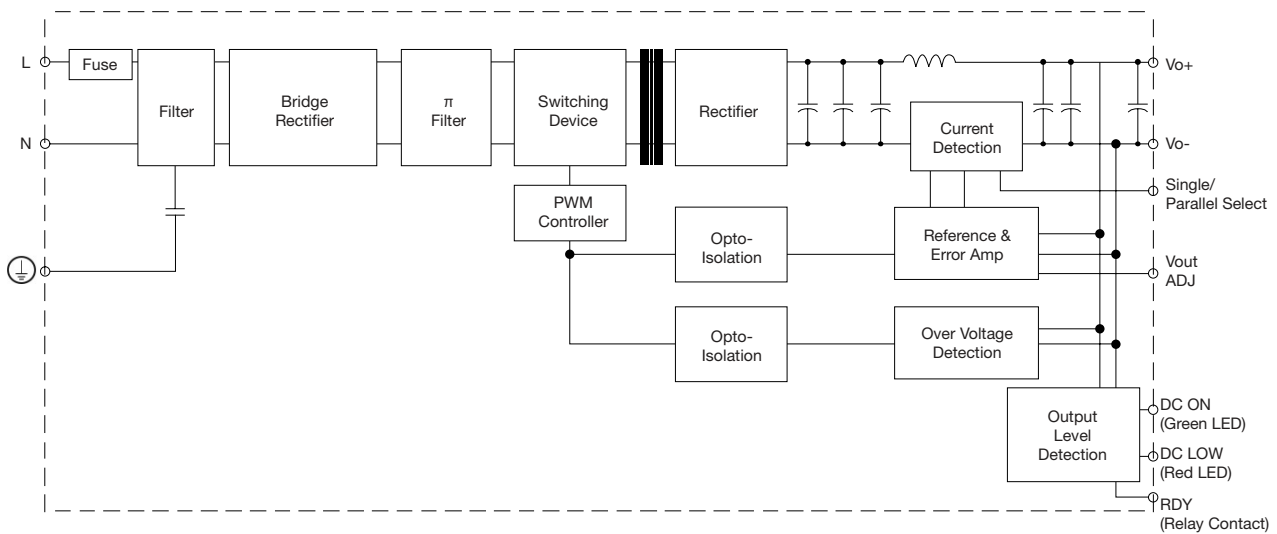

Pin Assignment and Front Controls

Pin No.	Designation	Description
1	RDY	A normal open relay contact for DC ON level control
2		Never connect
3, 4	V+	Positive output terminal
5, 6	V-	Negative output terminal
7	⊥	Ground this terminal to minimize high-frequency emissions
8	N	Input terminals (neutral conductor, no polarity at DC input)
9	L	Input terminals (phase conductor, no polarity at DC input)
	DC ON	Operation indicator LED
	DC LO	DC LOW voltage indicator LED
	Vout ADJ	Trimmer-potentiometer for Vout adjustment

Typ. Efficiency Curve

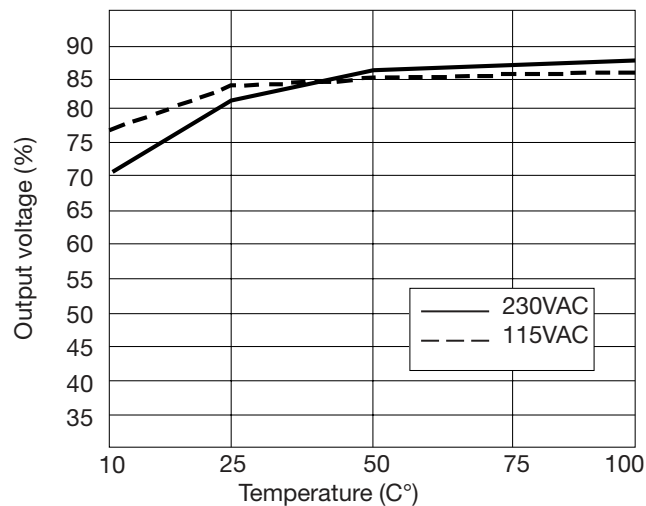

Derating Diagram

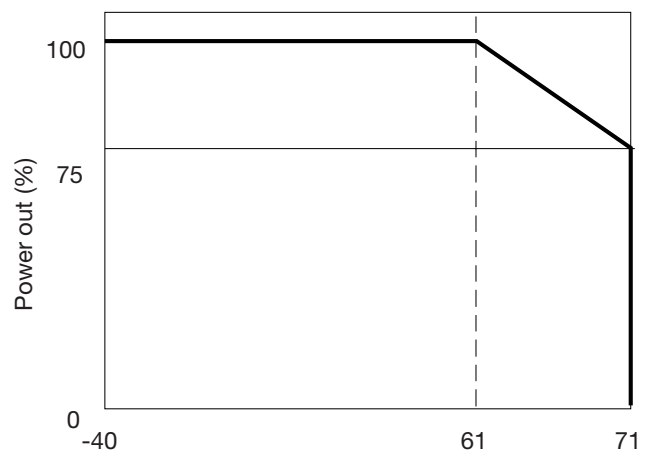

Typ. Current Limited Curve

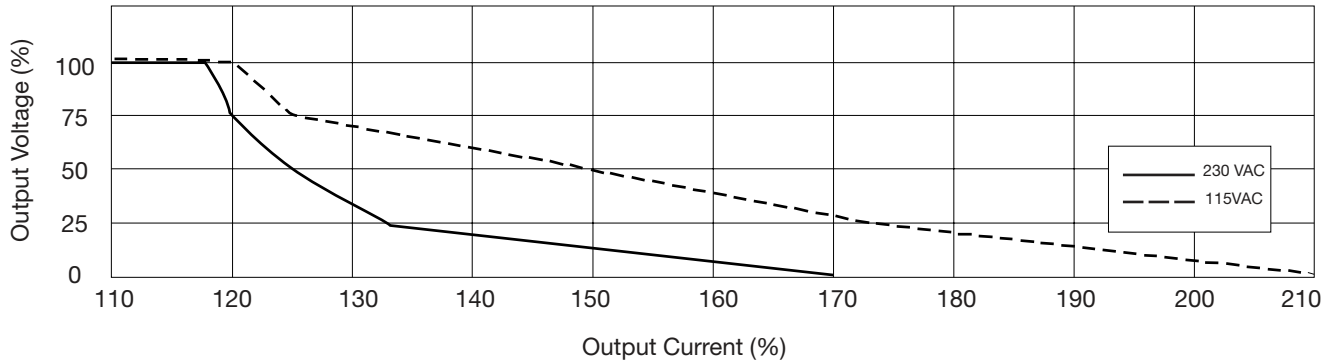

Installation

Ventilation and cooling	Normal convection All sides 25mm free space for cooling is recommended	Max. torque for terminal	
		Input terminal	0.56Nm (5.0lb-in)
		Output terminal	0.56Nm (5.0lb-in)
Connector size range		General tolerance mm(in.)	
Spring terminal	AWG24-14 (0.2~2mm ²) flexible/solid cable, 10mm stripping at cable and recommends use copper conductors only, 60/75°C	0.00 (0.00) ÷ 30.00 (1.18)	±0.30 (0.01)
Screw terminal	AWG26-12 (0.2~2.5mm ²) flexible/solid cable, connector can withstand torque at max 0,56Nm (5 lbs-in). 4-5 mm stripping at cable and recommends use copper conductors only, 60/75°C	30.00 (1.18) ÷ 120.00 (4.72)	±0.50 (0.02)

Mechanical Drawings mm (inches)

