

APPROVED: _____
 DATE: _____ TITLE: _____

| Rev | AWO # | Description | Date | Appr |
|-----|-------|----------------|----------|-------|
| - | | RELEASED | 11/20/19 | |
| A | | UPDATE DRAWING | 6/11/20 | AY/RC |
| B | | ADDED PACKING | 11/9/20 | OW/RC |
| C | | UPDATE TITLE | 4/19/22 | LH/TW |

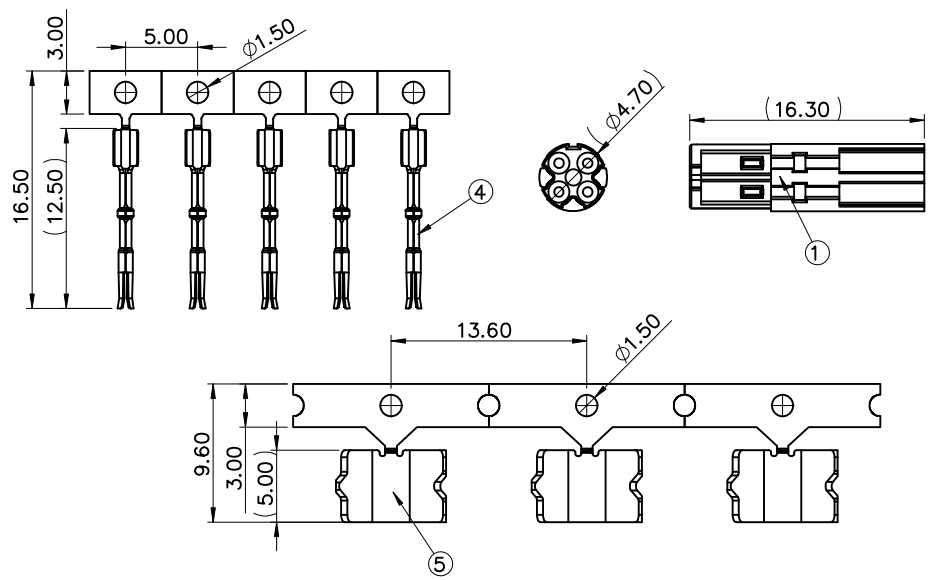
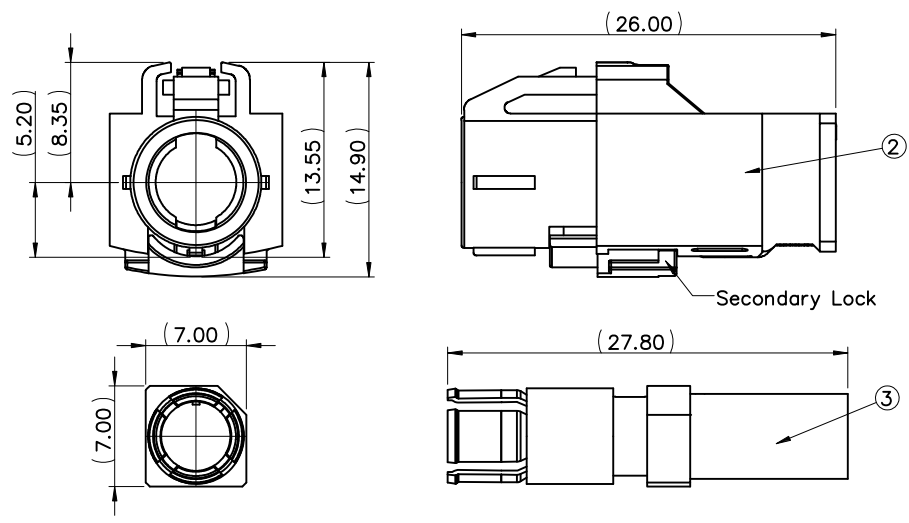

SPECIFICATIONS:

Material:
 Insulator: PBT, rated UL 94V-0
 Contacts: Phosphor Bronze
 Contact Sleeve: Phosphor Bronze
 Outer Contacts: Brass
Plating:
 6u" Gold over Nickel underplate on contact area,
 Tin over Copper underplate on solder tails
Electrical:
 Impedance, differential mode: 100 ohms differential signalling, for one pair
 or quad cable shielded

Frequency: DC to 2.0 GHz
 Return loss: ≥ 20 dB to 1.0GHz
 ≥ 17 dB to 2.0GHz
 Insertion loss: ≤ 0.1 dB @ 1.0GHz
 Insulation resistance: 1,000 Mohms min
 Signal contact resistance: 10 Mohms max
Mechanical:
 Mating Cycles: ≥ 25 Cycles
 Engagement force: ≤ 30 N
 Disengagement force: ≥ 5 N
 Retention force latch: ≥ 110 N
 Coding efficiency: ≥ 80 %
 Temperature Rating:
 -40°C to +105°C
Environmental:
 Lead free, RoHS compliant



MATERIALS AND FINISHES

| Item | Part Name | Material | Finishes | Qty |
|------|---------------------|------------------------|---|-----|
| 1 | Inner Housing | PBT | White | 1 |
| 2 | Shroud with TPA | PBT | See Table | 1 |
| 2-1 | Coding Housing | | | |
| 2-2 | Secondary Lock | | | |
| 3 | Shell Sub- Assembly | Brass & Phospor Bronze | 50u"~200u" Nickel | 1 |
| 3-1 | Machining Shell | | | |
| 3-2 | Front Spring | | | |
| 4 | Center Contact | Corrosion Copper | Contact Area: 6u" Gold Solder Area: 40u"~150u" Tin | 4 |
| 5 | Cable Clip | Brass | 100u"~200u" Tin | 1 |

UNLESS OTHERWISE SPECIFIED
 ALL DIMENSIONS ARE MILLIMETERS
 TOLERANCES: EXCEPT AS NOTED
 ANGLE
 MM
 X. ± 0.50
 .X ± 0.30
 .XX ± 0.20
 $\pm 5^\circ$



909 Rahway Avenue,
 Union, NJ 07083
 Phone: 908-687-5000
 Fax: 908-687-5710

TITLE
 HSD FAKRA CRIMP TERMINAL TYPE SOCKET WITH
 4P CRIMP HOUSING

| APPROVALS | | DATE |
|-----------|----|----------|
| DRAWN | OW | 11/20/19 |
| CHECKED | AC | 11/20/19 |
| APPROVED | | |

| SIZE | PART NO. | REV. |
|------|--------------------|--------------|
| X | HSD-04X-S-SD-SG-C4 | C |
| REF: | S00013T | SCALE: NTS |
| | | SHEET 1 OF 3 |

6

5

4

3

2

1

APPROVED: _____
DATE: _____ TITLE: _____

| | | | | |
|-----|-------|-------------|------|------|
| Rev | AWO # | Description | Date | Appr |
|-----|-------|-------------|------|------|

SEE SHT 1 OF 3 FOR REVISION

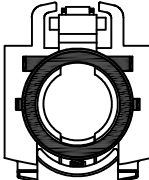
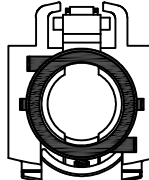
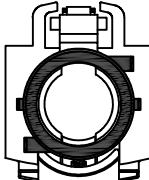
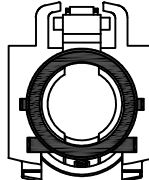
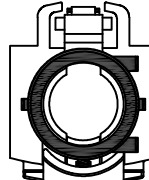
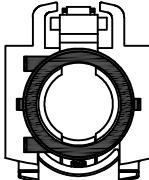
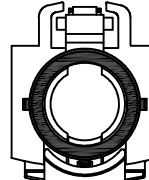
| Coding | A | B | C | D | E | F | Z |
|----------|---|---|---|---|---|---|---|
| Plug |  |  |  |  |  |  |  |
| Colour | black | white | blue | bordeaux | green | brown | waterblue |
| Part NO. | HSD-04A-S-SD-SG-C4 | HSD-04B-S-SD-SG-C4 | HSD-04C-S-SD-SG-C4 | HSD-04D-S-SD-SG-C4 | HSD-04E-S-SD-SG-C4 | HSD-04F-S-SD-SG-C4 | HSD-04Z-S-SD-SG-C4 |

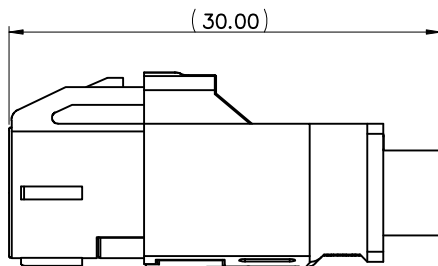
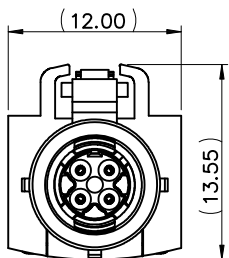
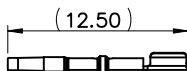

UNLESS OTHERWISE SPECIFIED
ALL DIMENSIONS ARE MILLIMETERS
TOLERANCES: EXCEPT AS NOTED
ANGLE

MM

X. ± 0.50
.X ± 0.30
.XX ± 0.20

±5°

ADAM
TECH

909 Rahway Avenue,
Union, NJ 07083
Phone: 908-687-5000
Fax: 908-687-5710

TITLE
HSD FAKRA CRIMP TERMINAL TYPE SOCKET WITH
4P CRIMP HOUSING

| | | |
|-----------|----|----------|
| APPROVALS | | DATE |
| DRAWN | OW | 11/20/19 |
| CHECKED | AC | 11/20/19 |
| APPROVED | | |

| | | |
|--------------|--------------------------------|--------------|
| SIZE X | PART NO. HSD-04X-S-SD-SG-C4 | REV. C |
| REF: S00013T | SCALE: NTS | SHEET 2 OF 3 |

6

5

4

3

2

1

APPROVED: _____

DATE: _____ TITLE: _____

| | | | | |
|-----------------------------|-------|-------------|------|------|
| Rev | AWO # | Description | Date | Appr |
| SEE SHT 1 OF 3 FOR REVISION | | | | |

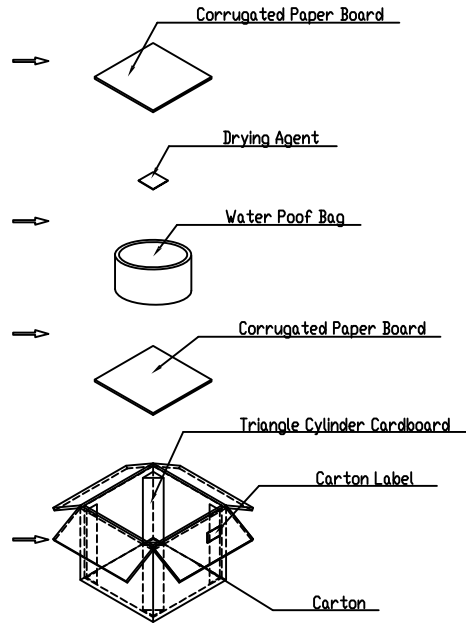
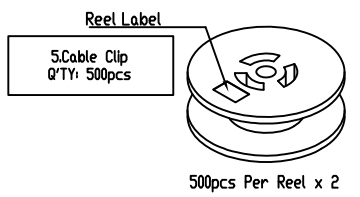
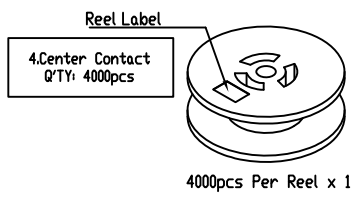
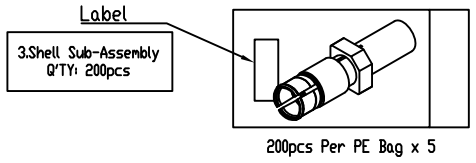
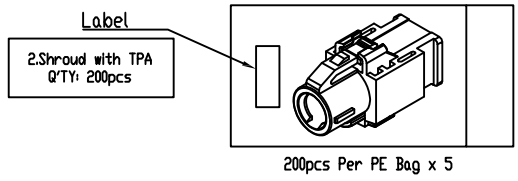
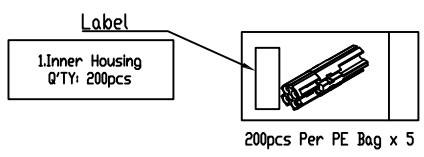

1000 Set Per Outer Carton Box
350x350x300

Fill in a corrugated paper board.
Put 4 triangle cylinder cardboard in all corner.
Put products into water proof bag,
with 4pcs of drying agent.
Make all reel label side up.
Cover with corrugated paper board.
As the indication sticking the label at
the certain place of carton.

NOTES
1. MATERIALS: Box
2. PACKING : 1000 PCS/CARTON
All Material in According With The
RoHs Environment
Related Substances List Controlle

| Items | Qty | Total |
|-----------------------------|----------------|----------------|
| 1 | 200pcs/Bag | 1000pcs/Carton |
| 2 | 200pcs/Bag | 1000pcs/Carton |
| 3 | 200pcs/Bag | 1000pcs/Carton |
| 4 | 4000pcs/Reel | 4000pcs/Carton |
| 5 | 500pcs/Reel | 1000pcs/Carton |
| Detailed Items | | |
| Items | Dimension | Amount |
| Carton | 350x350x300mm | 1 pcs |
| Corrugated paper board | 330x330mm | 2 pcs |
| Triangle cylinder cardboard | | 4 pcs/Carton |
| Water proof bag | 600x600mm | 1 pcs |
| Drying agent | 2g | 4 pcs/Carton |
| Paper tray | ∅ 350mm | 3 pcs |
| Styrofoam | HxD (20x200)mm | 4 pcs |

UNLESS OTHERWISE SPECIFIED
ALL DIMENSIONS ARE MILLIMETERS
TOLERANCES: EXCEPT AS NOTED
ANGLE

| | | |
|-----|--------|-------|
| | MM | ANGLE |
| .X | ± 0.50 | |
| .X | ± 0.30 | ±5° |
| .XX | ± 0.20 | |

| APPROVALS | | DATE |
|-----------|----|----------|
| DRAWN | OW | 11/20/19 |
| CHECKED | AC | 11/20/19 |
| APPROVED | | |

ADAM TECH 909 Rahway Avenue,
Union, NJ 07083
Phone: 908-687-5000
Fax: 908-687-5710

TITLE: HSD FAKRA CRIMP TERMINAL TYPE SOCKET WITH
4P CRIMP HOUSING

| | | |
|--------------|--------------------------------|--------------|
| SIZE X | PART NO. HSD-04X-S-SD-SG-C4 | REV. C |
| REF: S00013T | SCALE: NTS | SHEET 3 OF 3 |