

RE.F2-H | Medium-heavy duty castors

Soft polyurethane coating



- 1
- 2
- 3
- 4
- 5
- 6
- 7
- 8
- 9
- 10
- 11
- 12
- 13
- 14
- 15
- 16
- 17
- 18

COVERING

Soft mould-on polyurethane, hardness 75 Shore A.

WHEEL CENTRE BODY

Pressure die-cast aluminium.

ROLLING ACTION

Hub with ball bearings.

Ideal solution for heavy loads and continuous moving.

FIXED PLATE BRACKET

Yellow zinc-plated steel sheet. The bracket is designed to withstand loads up to 7000N.

It ensures capacities that make it suitable for heavy industrial applications.

TURNING PLATE BRACKET

Yellow zinc-plated steel sheet. The bracket is designed to withstand loads up to 7000N. It ensures capacities that make it suitable for heavy industrial applications.

It consists of (see Fig.1):

1. fitting plate: yellow zinc-plated steel sheet;
2. fork: yellow zinc-plated steel sheet;
3. ball race ring: yellow zinc-plated steel sheet;
4. central pin: class 8.8 steel screw and steel nut;
5. rotation system: dual grease-lubricated ball race;
6. dust seal: RAL 7015 dark grey technopolymer.

BRAKE

Front brake (RE.F2-100) or rear brake (RE.F2-125-160-200) dual-effect with simultaneous locking of wheel and bracket.

The brake is simple and effective to use: it is actuated and released by a simple action from the top downward at the tip of two separate pedals, thus ensuring the utmost manoeuvring comfort.

On wheels with a rear brake, the braking efficacy may be adjusted with a socket head screw M8.

STANDARD EXECUTIONS

- **PSL-H**: fixed plate bracket, without brake.
- **SSL-H**: turning plate bracket, without brake.
- **SSF-H**: turning plate bracket, with brake.

APPLICATIONS

Excellent rolling resistance and elasticity features, high wear and tearing resistance.

For further information see wheel technical data sheet RE.F2 (see page -).

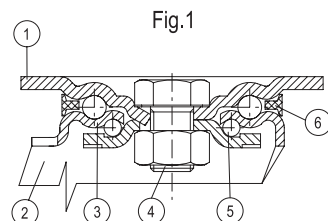

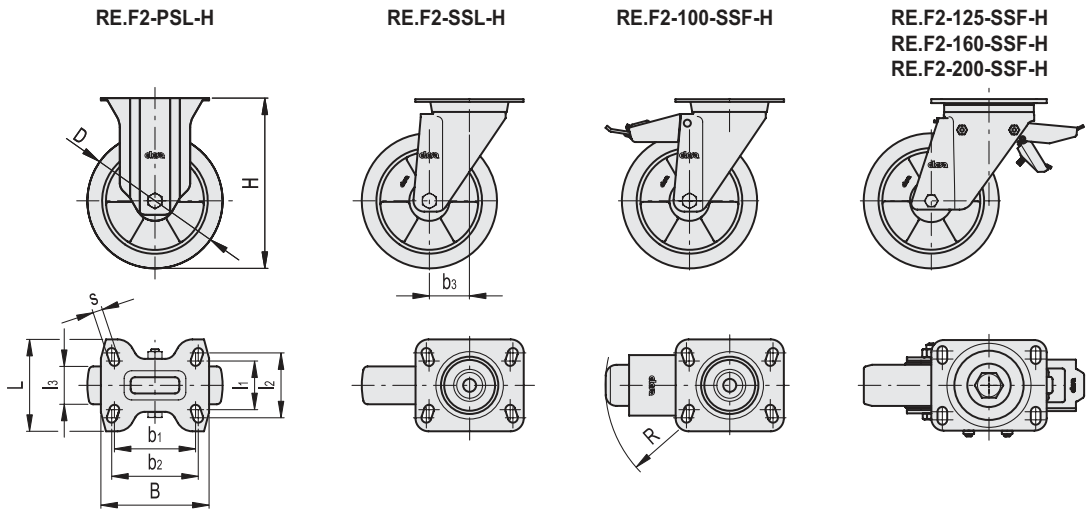

Conversion Table	
1 mm = 0.039 inch	
D	
mm	inch
100	3.94
125	4.92
160	6.30
200	7.87

RE.F2-PSL-H

METRIC

Code	Description	D	l1	l2	l3	H	B	L	s	b1	b2	Rolling resistance# [N]	Dynamic carrying capacity# [N]	⚖️
452461	RE.F2-100-PSL-H	100	45	60	40	138	100	85	9	75	80	3000	3000	850
452462	RE.F2-125-PSL-H	125	73	87	40	170	140	110	11	105	105	3500	3500	1690
452463	RE.F2-160-PSL-H	160	73	87	50	205	140	110	11	105	105	5500	5500	2110
452464	RE.F2-200-PSL-H	200	73	87	50	250	140	110	11	105	105	7000	7000	2850

RE.F2-SSL-H

METRIC

Code	Description	D	l1	l2	l3	H	B	L	s	b1	b2	b3	Rolling resistance# [N]	Dynamic carrying capacity# [N]	⚖️
452421	RE.F2-100-SSL-H	100	45	60	40	138	100	85	9	75	80	46	3000	3000	1350
452422	RE.F2-125-SSL-H	125	73	87	40	170	140	110	11	105	105	70	3500	3500	2330
452423	RE.F2-160-SSL-H	160	73	87	50	205	140	110	11	105	105	70	5500	5500	2600
452424	RE.F2-200-SSL-H	200	73	87	50	250	140	110	11	105	105	70	7000	7000	4310

RE.F2-SSF-H

METRIC

Code	Description	D	l1	l2	l3	H	B	L	s	b1	b2	b3	R	Rolling resistance# [N]	Dynamic carrying capacity# [N]	⚖️
452441	RE.F2-100-SSF-H	100	45	60	40	138	100	85	9	75	80	46	123	3000	3000	1520
452442	RE.F2-125-SSF-H	125	73	87	40	170	140	110	11	105	105	70	126	3500	3500	2860
452443	RE.F2-160-SSF-H	160	73	87	50	205	140	110	11	105	105	70	126	5500	5500	4170
452444	RE.F2-200-SSF-H	200	73	87	50	250	140	110	11	105	105	70	126	7000	7000	4910

For rolling resistance and dynamic carrying capacity see Technical data (on page 1296).

