

NO. OF CIRC. "XX"	DIM. "A"		DIM. "B"		MATERIAL NUMBER
	mm	in	mm	in	
02	10.7	.42	5.08	.200	398801202
03	15.7	.62	10.16	.400	398801203
04	20.8	.82	15.24	.600	398801204
05	25.9	1.02	20.32	.800	398801205
06	31.0	1.22	25.40	1.000	398801206
07	36.1	1.42	30.48	1.200	398801207
08	41.1	1.62	35.56	1.400	398801208
09	46.2	1.82	40.64	1.600	398801209
10	51.3	2.02	45.72	1.800	398801210
11	56.4	2.22	50.80	2.000	398801211
12	61.5	2.42	55.88	2.200	398801212
13	66.5	2.62	60.96	2.400	398801213
14	71.6	2.82	66.04	2.600	398801214
15	76.7	3.02	71.12	2.800	398801215
16	81.8	3.22	76.20	3.000	398801216
17	86.9	3.42	81.28	3.200	398801217
18	91.9	3.62	86.36	3.400	398801218
19	97.0	3.82	91.44	3.600	398801219
20	102.1	4.02	96.52	3.800	398801220
21	107.2	4.22	101.60	4.000	398801221
22	112.3	4.42	106.68	4.200	398801222
23	117.3	4.62	111.76	4.400	398801223
24	122.4	4.82	116.84	4.600	398801224
25	127.5	5.02	121.92	4.800	398801225

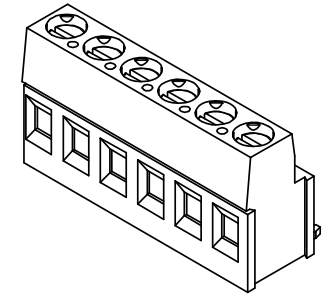

AUX. VIEW
(6 CIRCUIT SHOWN)

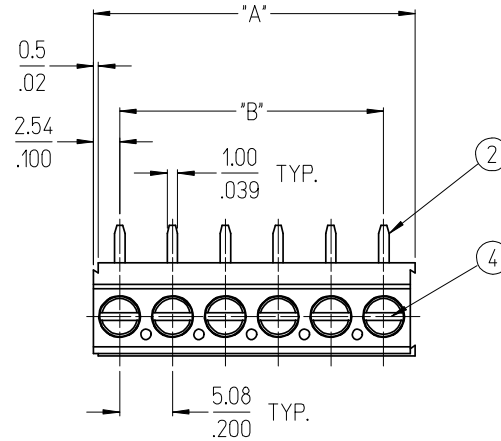
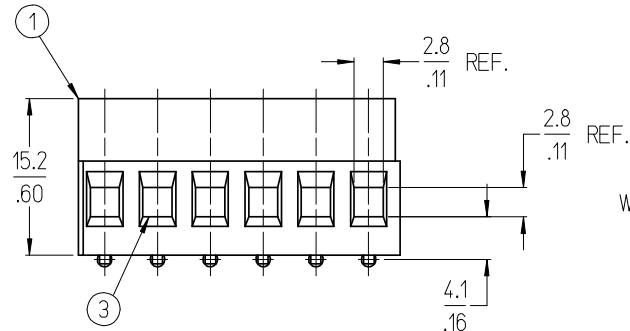

WIRE ENTRY

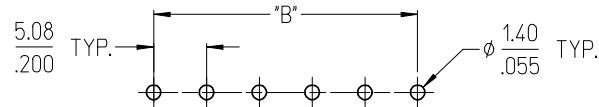
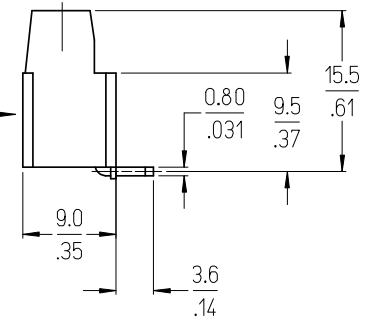

RECOMMENDED PCB LAYOUT

NOTES:

1. MATERIAL: SEE TABLE
2. FINISHES: SEE TABLE
3. "XX" REFERS TO QUANTITY OF CIRCUITS.
4. WIRE RANGE: 30 - 12 AWG
5. RATED VOLTAGE: 300V
6. RATED CURRENT: 17.5 A
7. RECOMMENDED TIGHTENING TORQUE: 0.5 N-m (4.4 lbf-in)
MAXIMUM TIGHTENING TORQUE: 0.6 N-m (5.3 lbf-in)
8. WIRE STRIP LENGTH: 6 mm (.24 in).
9. OPERATING TEMPERATURE: -40°C TO 105°C.
10. ASSEMBLY IS ROHS COMPLIANT.

ITEM	QTY.	DESCRIPTION	MATERIAL	FINISH
4	XX	SCREW, M3	COPPER ALLOY	NICKEL PLATED
3	XX	CLAMP, RISING	COPPER ALLOY	NICKEL PLATED
2	XX	TERMINAL, RIGHT ANGLE	COPPER ALLOY	TIN PLATED
1	1	HOUSING, UL94 V-0	PA66	BLACK

INITIAL RELEASE
EC NO: ETC2007-0345
DRWN: CLYORK 2007/03/28
CHKD: JMACNEIL 2007/04/03
APPR: JMACNEIL 2007/04/03

QUALITY SYMBOLS
▽=0
▽=0

GENERAL TOLERANCES (UNLESS SPECIFIED)

	mm	INCH
4 PLACES	±---	±---
3 PLACES	±---	±.005
2 PLACES	±0.13	±.01
1 PLACE	±0.25	±---

ANGULAR ± 2 °

DRAFT WHERE APPLICABLE
MUST REMAIN
WITHIN DIMENSIONS

DIMENSION STYLE
MM/IN

SCALE
2:1

DESIGN UNITS
METRIC

THIRD ANGLE PROJECTION

DRAWN BY
C. YORK

DATE
2007/03/19

CHECKED BY
J. MACNEIL

DATE
2007/03/19

APPROVED BY
J. MACNEIL

DATE
2007/03/19

MATERIAL NO.
SEE CHART

SIZE
B

TITLE
5.08MM [.200] FIXED,
RIGHT ANGLE, EUROSTYLE

MOLEX INCORPORATED

DOCUMENT NO.
SD-39880-011

SHEET NO.
1 OF 1

THIS DRAWING CONTAINS INFORMATION THAT IS PROPRIETARY TO MOLEX INCORPORATED AND SHOULD NOT BE USED WITHOUT WRITTEN PERMISSION