

REVISIONS					
P	LTR	DESCRIPTION	DATE	DN	APVD
C1		REVISED PER ECR-21-117154	03AUG2022	SKR	VS

- PARTS COMPLY WITH AMP SOLDERABILITY SPECIFICATION 109-11-5.
- DIMENSIONS IN BRACKETS ARE IN INCHES.
- CIRCUIT IDENTIFICATION CHARACTERS ARE ADJACENT TO THE INDICATED CAVITIES, BUT LOCATION AND ORIENTATION MAY DIFFER FROM PRINT.
- DIMENSION SHOWN REPRESENT PRODUCT IN DRY CONDITION. ADDITIONAL 2% GROWTH DUE TO END USE LOCATION MOISTURE ABSORPTION MAY OCCUR AND SHOULD BE ACCOUNTED FOR.

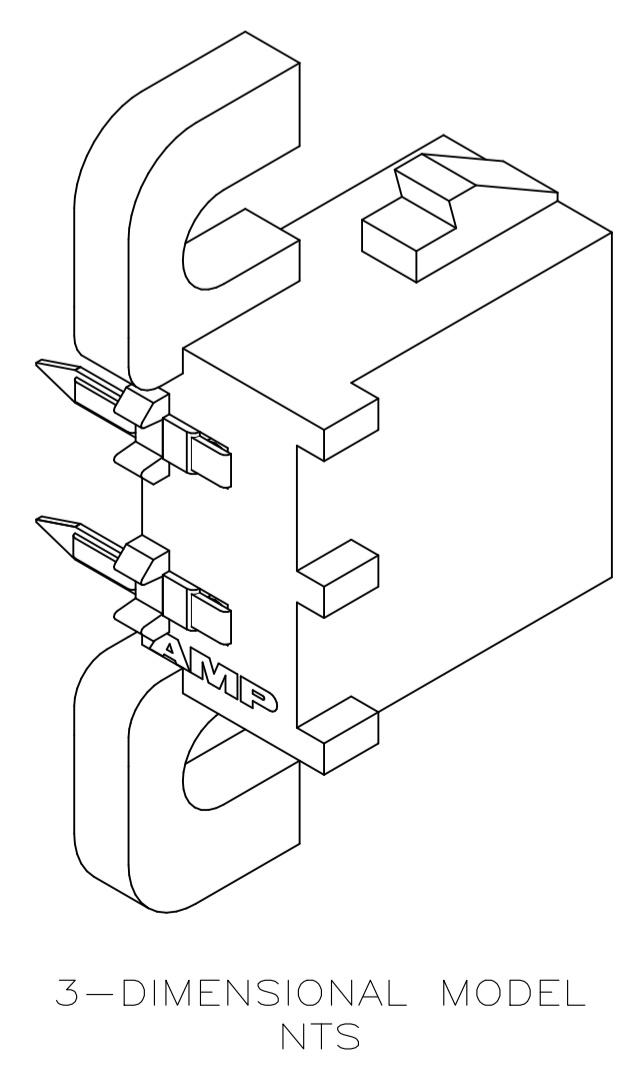
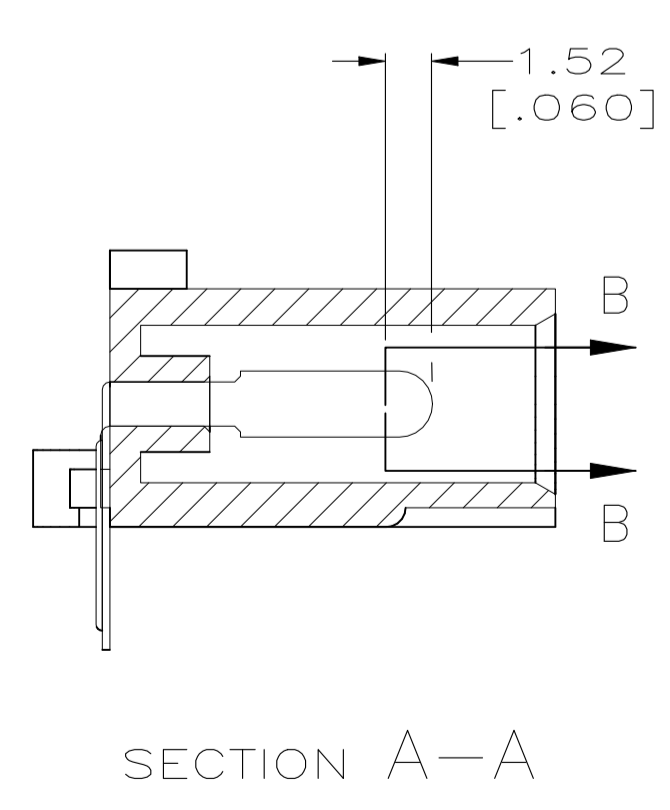
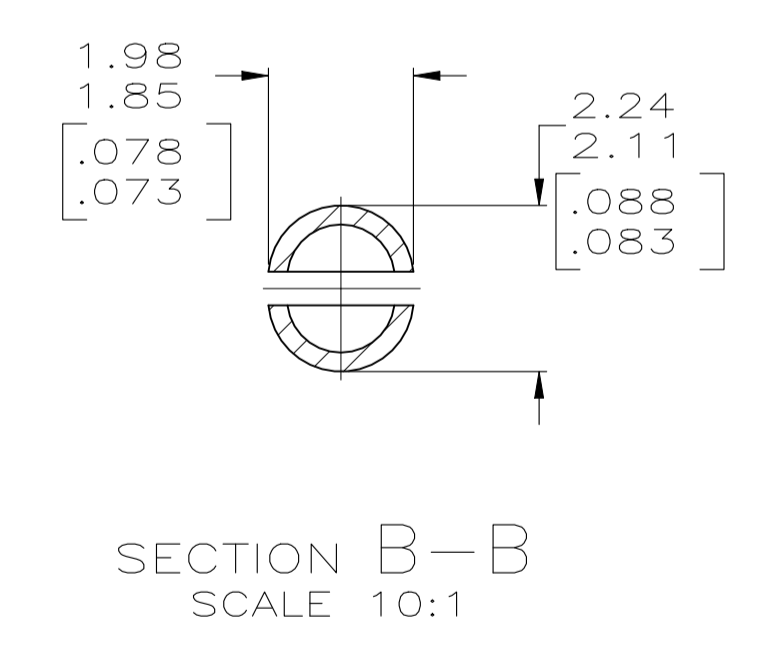
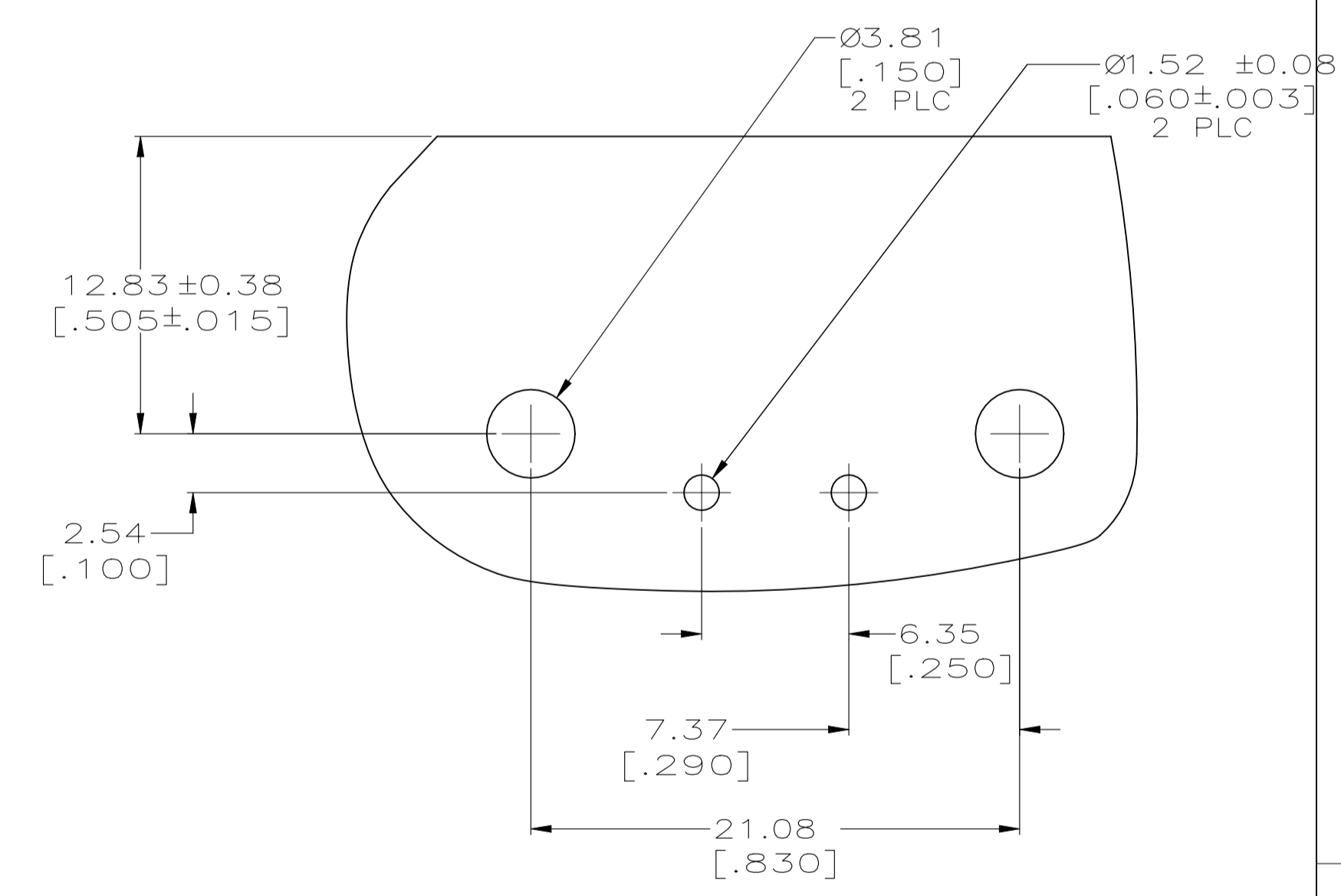
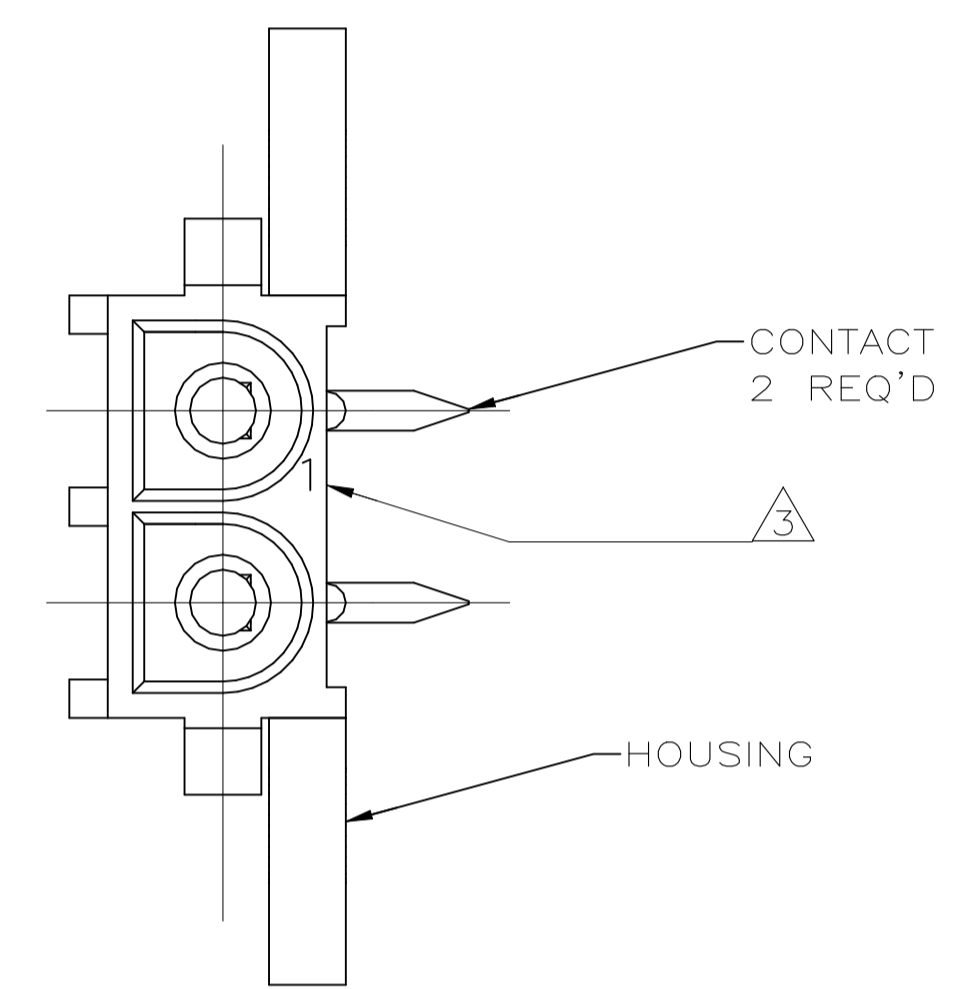
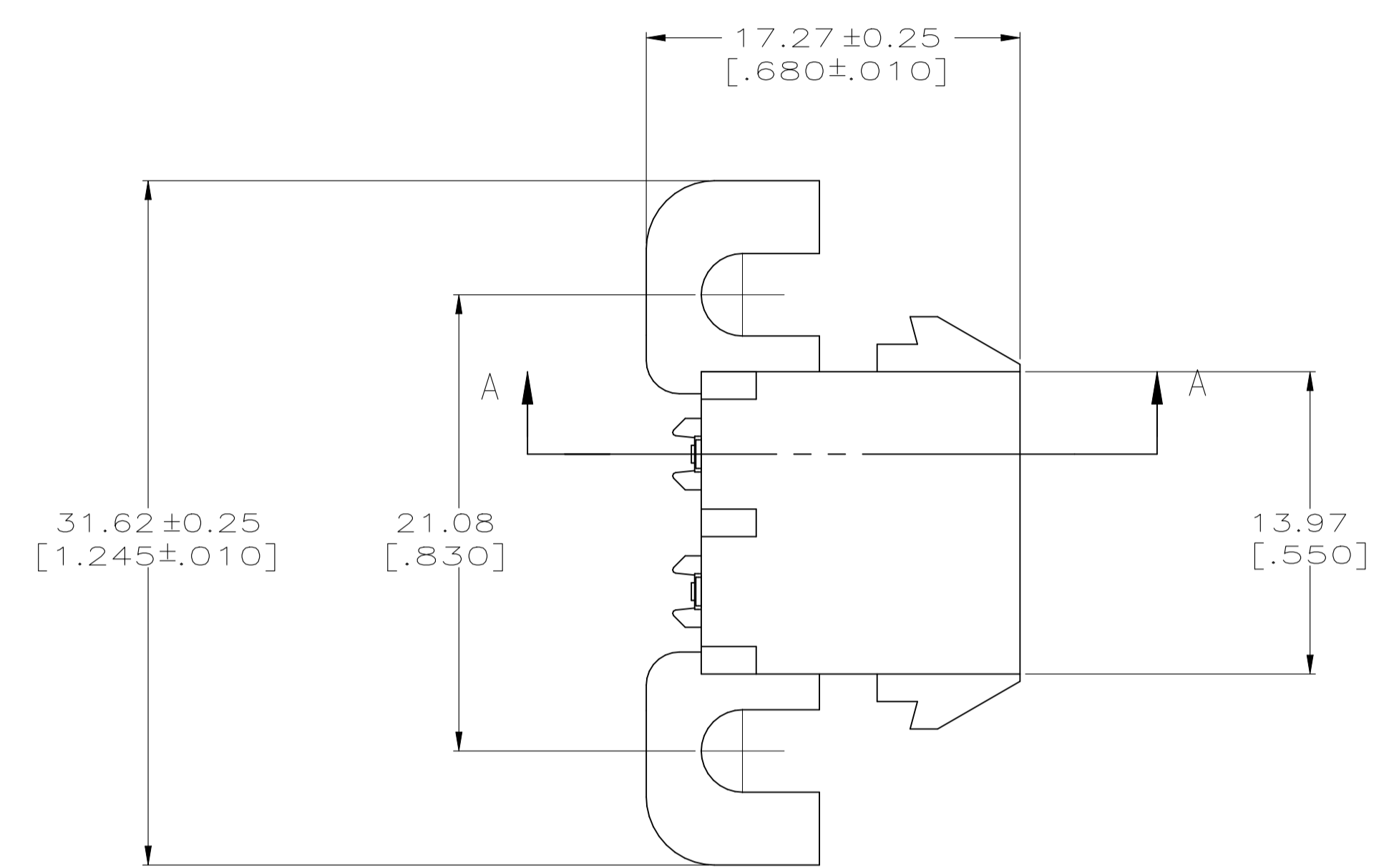
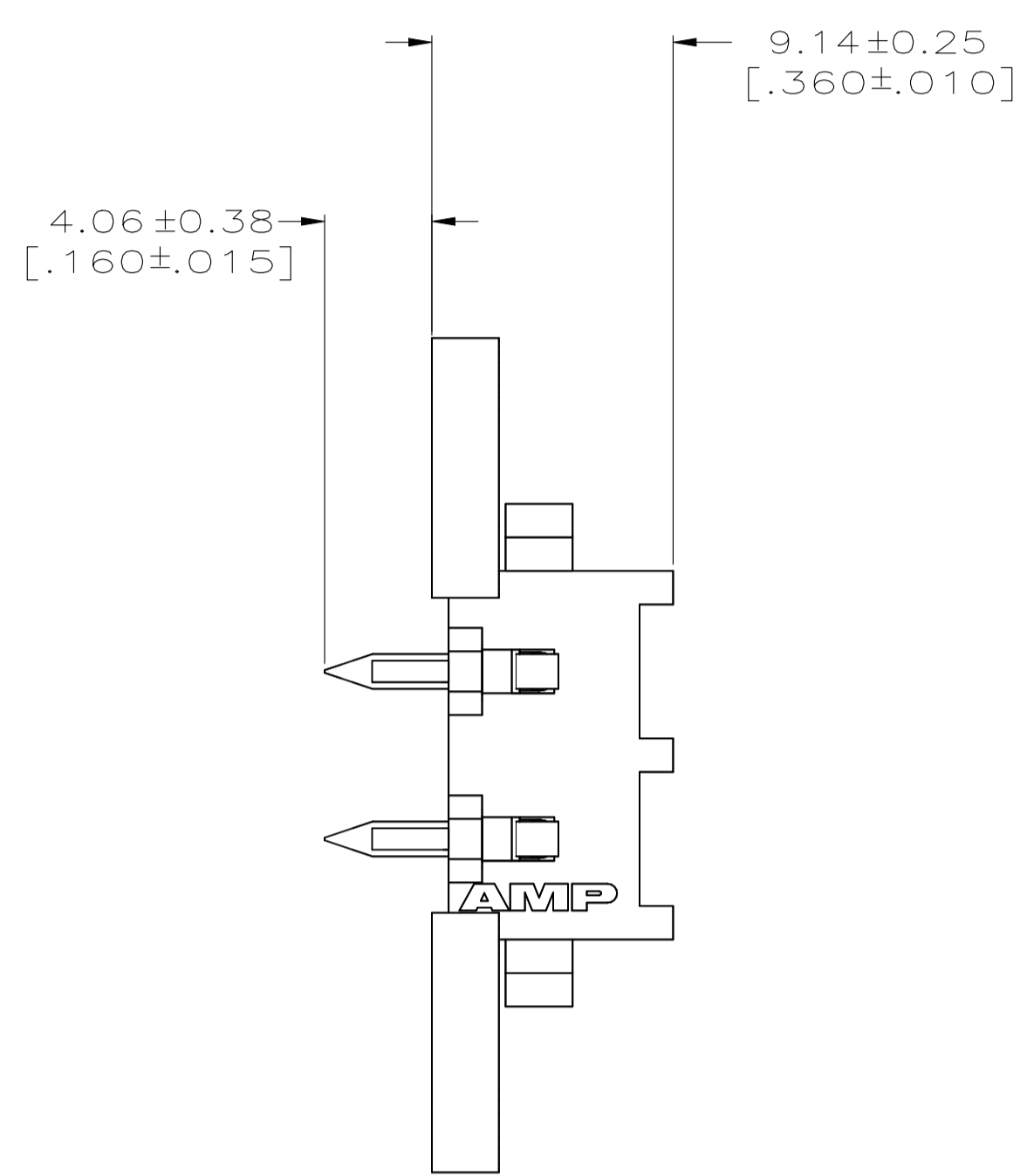

**METRIC**

PHOS BRONZE, PRE-TIN		NYLON UL94V-0	770994-1
CONTACT		HOUSING	PART NO
THIS DRAWING IS A CONTROLLED DOCUMENT. DIMENSIONS: MM [ INCHES ] TOLERANCES UNLESS OTHERWISE SPECIFIED: 0. PLC ± - 1. PLC ± - 2. PLC ± - 3. PLC ± 0.13 [.005] 4. PLC ± - ANGLES ± - MATERIAL: SEE TABLE FINISH: SEE TABLE		DIN 8-17-92 R. LEWIS R. SWING R. BROWN PRODUCT SPEC APPLICATION SPEC WEIGHT: 0.000000 CUSTOMER DRAWING	NAME: PIN HEADER ASSEMBLY, RIGHT ANGLE MOUNT, 2 POSITION, UNIVERSAL MATE-N-LOK SIZE: A1 CAGE CODE: 00779 DRAWING NO: 770994 SCALE: 4:1 SHEET: 1 of 1 REV: C1