

PAGE 1/2	ISSUE 13-10-16A	SERIES ATTENUATOR	PART NUMBER R415420000
----------	-----------------	-----------------------------	-------------------------------

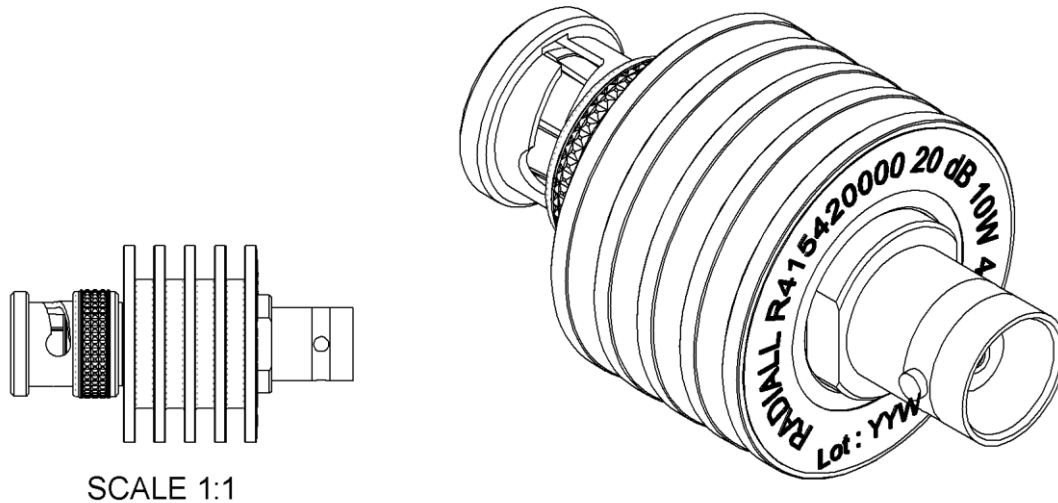

All dimensions are in mm.

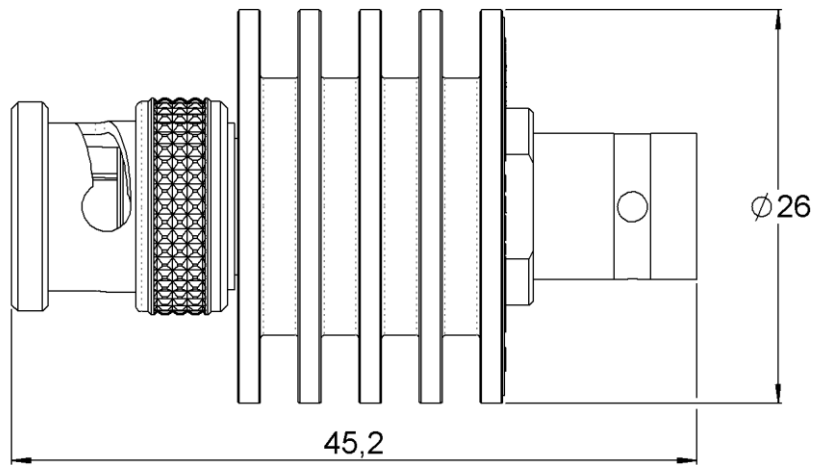
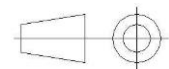

COMPONENTS	MATERIALS	PLATING (µm)
Body	BRASS	NICKEL 5
Male center contact	BRASS	GOLD 2.5 OVER NICKEL 1
Female center contact	BERYLLIUM COPPER	GOLD 2.5 OVER NICKEL 1
Outer contact	BRASS	-
Insulator	PTFE	
Gasket	SILICONE RUBBER	
Substrate	ALUMINIUM NITRIDE	
Resistor	THIN FILM	
Others parts	ALUMINIUM	BLACK ANODIZATION

PAGE 2/2	ISSUE 13-10-16A	SERIES ATTENUATOR	PART NUMBER R415420000
----------	-----------------	-----------------------------	-------------------------------

ELECTRICAL CHARACTERISTICS

Frequency (GHz)	DC - 4
V.S.W.R (≤)	1.20
Deviation(±dB)	0.50

Operating Frequency Range	DC - 4	GHz
Impedance	50	Ω
Nominal Attenuation	20	dB
Peak power at 25°C (1μs, 1%)	250	W
Average power at 25°C	10	W (Free Air Cooled)
		W (Conduction Cooled)

MECHANICAL CHARACTERISTICS

Connectors	BNC	Male Female	MIL-C 39012
Weight	37,000 g		

ENVIRONMENTAL CHARACTERISTICS

Operating temperature range	-55 /+125 °C
Storage temperature range	-55 /+125 °C

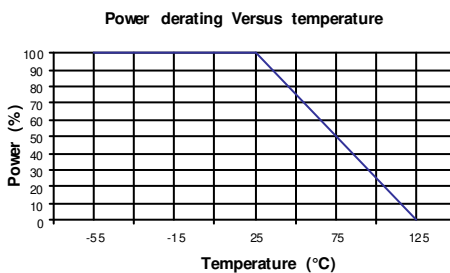

SPECIFICATION

OTHER CHARACTERISTICS