

H
G
F
E
D
C
B
A

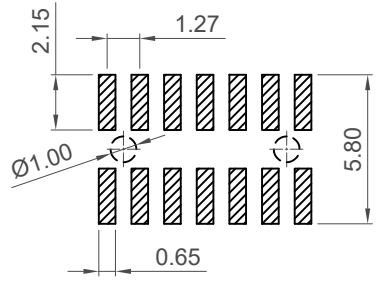

Recommended PCB Layout
Tolerance: ±0.05mm
Solder Area

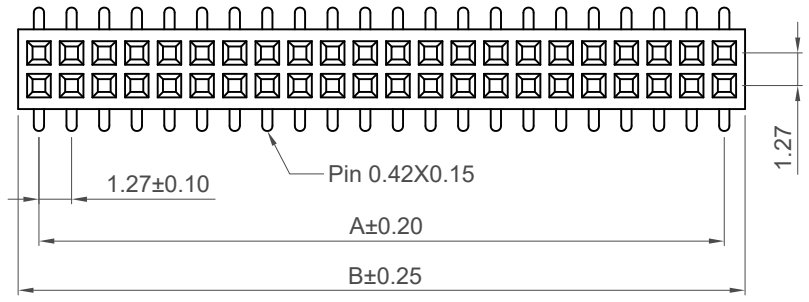
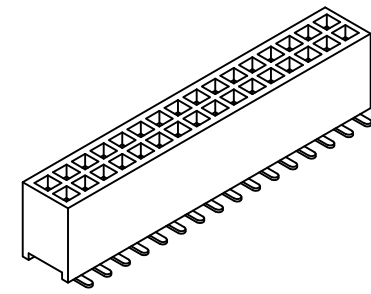

Number of Contacts	Dimensions		
	A	B	C
4	1.27	2.89	/
6	2.54	4.16	1.27
8	3.81	5.43	2.54
10	5.08	6.70	3.81
12	6.35	7.97	5.08
14	7.62	9.24	6.35
16	8.89	10.51	7.62
18	10.16	11.78	8.89
20	11.43	13.05	10.16
22	12.70	14.32	11.43
24	13.97	15.59	12.70
26	15.24	16.86	13.97
28	16.51	18.13	15.24
30	17.78	19.40	16.51
32	19.05	20.67	17.78
34	20.32	21.94	19.05
36	21.59	23.21	20.32
38	22.86	24.48	21.59
40	24.13	25.75	22.86
42	25.40	27.02	24.13
44	26.67	28.29	25.40
46	27.94	29.56	26.67
48	29.21	30.83	27.94
50	30.48	32.10	29.21
52	31.75	33.37	30.48
54	33.02	34.64	31.75
56	34.29	35.91	33.02
58	35.56	37.18	34.29
60	36.83	38.45	35.56
62	38.10	39.72	36.83
64	39.37	40.99	38.10
66	40.64	42.26	39.37
68	41.91	43.53	40.64
70	43.18	44.80	41.91
72	44.45	46.07	43.18
74	45.72	47.34	44.45
76	46.99	48.61	45.72
78	48.26	49.88	46.99
80	49.53	51.15	48.26
82	50.80	52.42	49.53
84	52.07	53.69	50.80
86	53.34	54.96	52.07
88	54.61	56.23	53.34
90	55.88	57.50	54.61
92	57.15	58.77	55.88
94	58.42	60.04	57.15
96	59.69	61.31	58.42
98	60.96	62.58	59.69
100	62.23	63.85	60.96

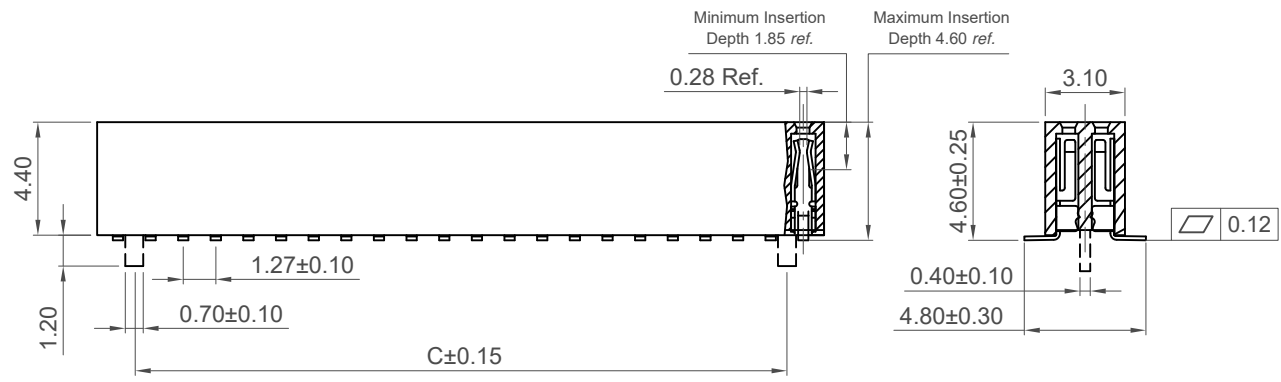

Specifications

Material
Insulator: Ploymer, LCP, UL94V-0
Contact: Copper Alloy

Plating
See Ordering Grid

Electrical
Current Rating: 1.0 Amp Per Pin
Contact Resistance: 20 mΩ max.
Insulation Resistance: 1000 MΩ min.
Dielectric Withstand Voltage: 300 V AC

Mechanical & Environmental
Operating Temperature: -40°C to +105°C
Soldering Process
IR Reflow: 260°C for 10 sec.
Wave Reflow: 250°C for 5~10 sec.
Manual Solder: 350°C for 3-5 sec

Mates with (Subject to Pin Length)
BD025 BD030 BD035 BD038
BD040 BD095

Ordering Grid

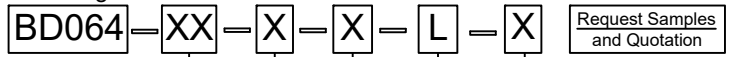

No. of Contacts
04 to 100
100 Contacts = 00

Contact Plating
A = Gold Flash All Over (Standard)
B = Selective Gold Flash Contact Area/
Tin On Tail
C = Tin All Over
G = 10μ" Gold Contact Area/Tin On Tail
I = 30μ" Gold Contact Area/Tin On Tail

Packing Options
C = Tape & Reel with Film (Standard)
B = Tape & Reel with Cap
(Not available for 4 contacts)
D = Tube
E = Tube with Cap
F = Tube with Film
Insulator Material
L = LCP
Locating Peg
0 = No Peg
1 = With Peg
(Not available for 4 contacts)

Part Number		Product Description	
BD064		1.27mm Pitch Socket, Dual Row, Surface Mount, Vertical	
Drawing Date		16th April 2008	
By	CC	Tolerances (Except as Noted)	Units:
Detail	BD064 E PCN	Length X ± 0.30 X.X ± 0.25 X.XX ± 0.15 X.XXX ± 0.10	Metric (mm)
Revision	E2	Angle X ° ± 5° X.X ° ± 3° X.XX ° ± 2° X.XXX ° ± 1°	3rd Angle Projection
Date	30/01/23		



This drawing is confidential and copyright of Global Connector Technology, Ltd (GCT). This drawing must not be copied or disclosed without written consent. E & OE



Not to Scale	Drawn By ASE	Sheet No. 1/1
--------------	--------------	---------------