

REV.	DATE	DESCRIPTION
NC	07/15/02	INITIAL RELEASE
A	05/01/04	UPDATE DRAWING FORMAT
B	12/10/07	ADD CABLE DESCRIPTION

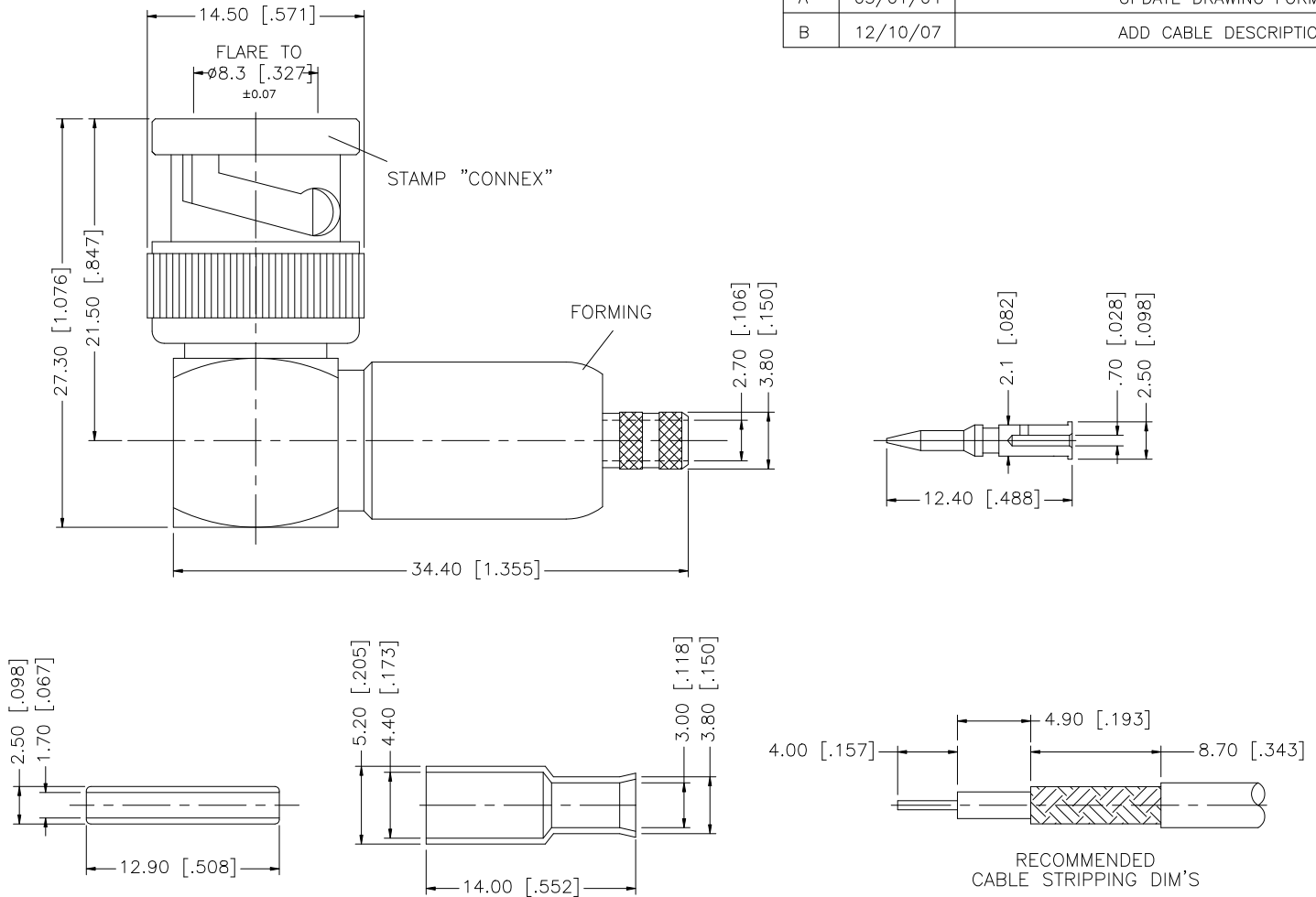

8				
7	FERRULE	BRASS	NICKEL	1
6	SLEEVE	DELTRIN	NATURAL	1
5	CONTACT PIN	BRASS	GOLD	1
4	CONTACT PIN	BRASS	GOLD	1
3	CONTACT PIN	PHOS. BRONZE	GOLD	1
2	INSULATOR	DELTRIN	NATURAL	1
1	BODY	BRASS	NICKEL	1
	DESCRIPTION	MATERIAL	FINISH	QTY

UNLESS OTHERWISE SPECIFIED DIMENSIONS ARE IN MILLIMETERS. DIMENSIONS IN [] ARE IN INCHES AND FOR CUSTOMER REFERENCE ONLY.

UNLESS OTHERWISE SPECIFIED TOLERANCES FOR MILLIMETERS ARE:
0.5 - 8mm ± 0.20mm
8 - 30mm ± 0.40mm
30 - 120mm ± 0.50mm

UNLESS OTHERWISE SPECIFIED TOLERANCES FOR INCHES ARE:
.020 - .315 = ± 0.007"
.315 - 1.180 = ± 0.015"
1.180 - 4.724 = ± 0.020"

DO NOT SCALE DRAWING

APPROVALS	DATE
DRAWN G.R.S.	12/10/07
CHECKED	
ISSUED	
SHEET 1 OF 1	
CAD FILE C:/112/112198.DWG	

Amphenol Connex

PART DESCRIPTION
**BNC R/A CRIMP PLUG
(FOR RG-174/316-U CABLE)**

PART NO.
112198

DWG. NO.	112198.DWG	REV.	B	SIZE	A	SCALE	NA
----------	------------	------	---	------	---	-------	----