

Motor Specifications

Part Number	BL17E40-02-R0
Dimension "A" Max	3.98 in [101mm]
Rated Voltage	48 VDC
Rated Torque	30.45 oz-in [0.215N-m]
Rated Speed	4000 RPM
Rated Power	90 Watts
Rated Current	2.4 Amps
Peak Torque	60.9 oz-in [0.43N-m]
Peak Current	4.8 Amps
Torque Constant (kt)	12.6 oz-in/Amp
Back EMF Constant (Ke)	8.6 Vp/KRPM
Motor Constant (Km)	10.4 oz-in/√W [0.073 N-m/√W]
Resistance	1.47 Ohms
Inductance	1.57 mH
Rotor Inertia	0.79 oz-in ²
Weight	1.83 lb [0.83 kg]
Electrical Time Constant	1.1 ms
Mechanical Time Constant	2.9 ms

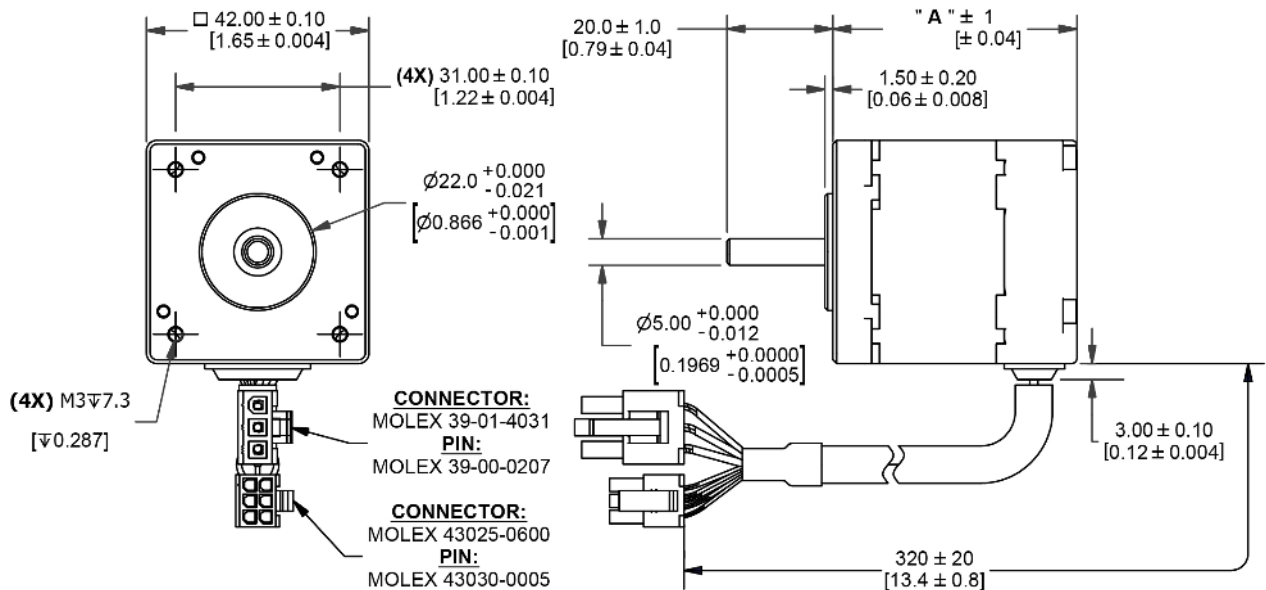

Dimensions



Performance Curve

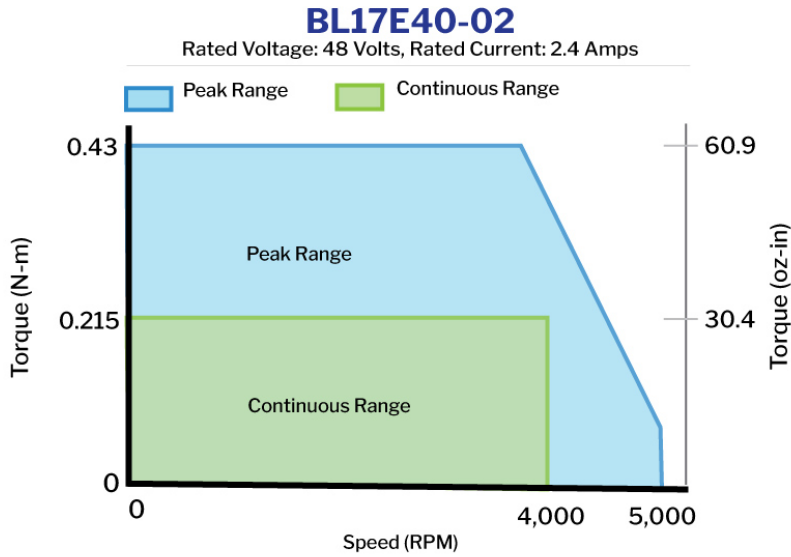

Motor Operating Specs.

Hall Effect Angle	120° electrical Angle
Radial Play	0.002 in [0.05 mm] @ 0.99 lbs [0.45 kg]
End Play	0.003 in [0.08 mm] @ 99.21 lbs [45.00 kg]
Max. Radial Force	0.394 in [10.00 mm] @ 3.37 lbs [1.53 kg]
Max. Axial Force	2.25 lbs [1.02 kg]
Insulation Class	Class B
Dielectric Strength	500 VDC for 1 minute
Insulation Resistance	100 Ω min, 500 VDC
Ambient Operating Temperature	-20°C to 50°C
Storage Temperature	-20°C to 100°C
Humidity Range (%)	85% (RH) non-condensing
Direction of Rotation	CCW

Recommended Products



BLDC DRIVER
BLDC50-BL17E40-02



BLDC EXTENSION CABLE
4201-100/300

Pin Out Charts

PIN #	COLOR	PHASE
1	RED	VCC (+5V)
2	YELLOW	HV
3	BLUE	HW
4	BLACK	GND
5	ORANGE	HU

PIN #	COLOR	PHASE
1	BLUE	W
2	ORANGE	U
5	YELLOW	V

Operation & Usage Tips



Do not disassemble motors; a significant reduction in motor performance will occur.

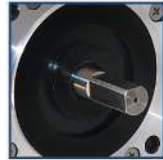

Do not machine shafts; this will have a negative effect on shaft run out and perpendicularity.

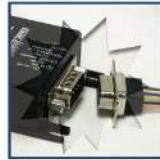

Do not disconnect motor from drive while in operation.

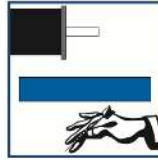

Do not use holding torque/detent torque of motor as a fail safe brake.



Do not hold motor by lead wires.



Do not exceed the rated current; this will burn the motor.

FAILURE TO COMPLY WITH THESE RECOMMENDATIONS WILL VOID ALL WARRANTY TERMS

Motion Control, **Solved.**

MOTOR ENGINEERING & MANUFACTURING



Optimized
For Your
Application



Quick
Prototype
Turnaround



Small Batch
to OEM Volume
Production



US Based
Support &
Manufacturing