

Product Features

- Maximum rated frequency: 133 MHz
- Low cycle-to-cycle jitter
- Input to output delay, less than 200ps
- Internal feedback allows outputs to be synchronized to the clock input
- Operates at 3.3V V_{DD}
- Space-saving Packages: (Pb-free & Green available)
150-mil SOIC (W)
173-mil TSSOP (L)

Functional Description

The PI6C2409-1 is a PLL based, zero-delay buffer, with the ability to distribute nine outputs of up to 133MHz at 3.3V. All the outputs are distributed from a single clock input CLKIN and output OUT0 performs zero delay by connecting a feedback to PLL.

PI6C2409-1 has two banks of four outputs that can be controlled by the selection inputs, SEL1 & SEL2. It also has a powersparing feature: when input SEL1 is 0 and SEL2 is 1, PLL is turned off and all outputs are referenced from CLKIN. PI6C2409-1 is available in high drive and industrial environment versions.

An internal feedback on OUT0 is used to synchronize the outputs to the input; the relationship between loading of this signal and the outputs determines the input-output delay. PI6C2409-1 are characterized for both commercial and industrial operation

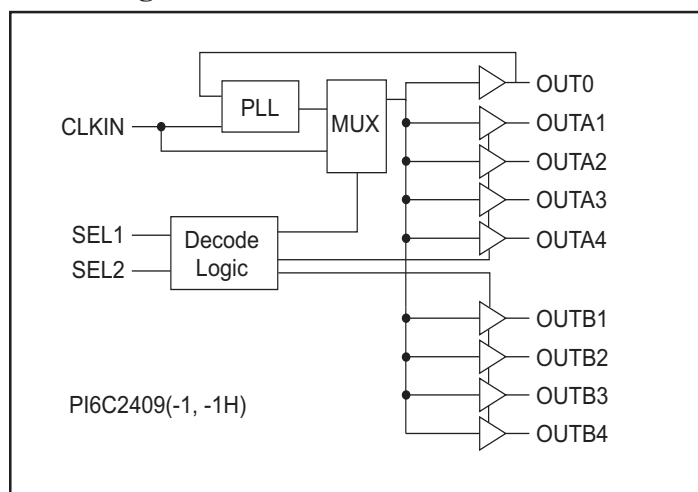
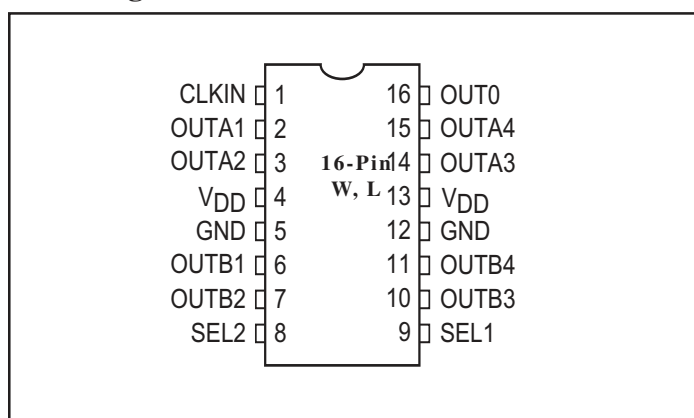
Block Diagram

Pin Configuration

Input Select Decoding

SEL2	SEL1	OUTA [1-4]	OUTB [1-4]	Output Source (OUT0)	PLL
0	0	3-State	3-State	PLL	ON
0	1	PLL	3-State	PLL	ON
1	0	CLKIN	CLKIN	CLKIN	OFF
1	1	PLL	PLL	PLL	ON

Pin Description

Pin	Signal	Description
1	CLKIN	Input clock reference frequency (weak pull-down)
2, 3, 14, 15	OUTA[1-4]	Clock outputs, Bank A
4, 13	V _{DD}	3.3V supply
5, 12	GND	Ground
6, 7, 10, 11	OUTB[1-4]	Clock outputs, Bank B
8	SEL2	Select input, bit 2 (weak pull-up)
9	SEL1	Select input, bit 1 (weak pull-up)
16	OUT0	Clock Output , internal PLL feedback

Zero-Delay and Skew Control

CLKIN Input to OUTx Delay vs. Difference in Loading between OUT0 pin and OUTx pins

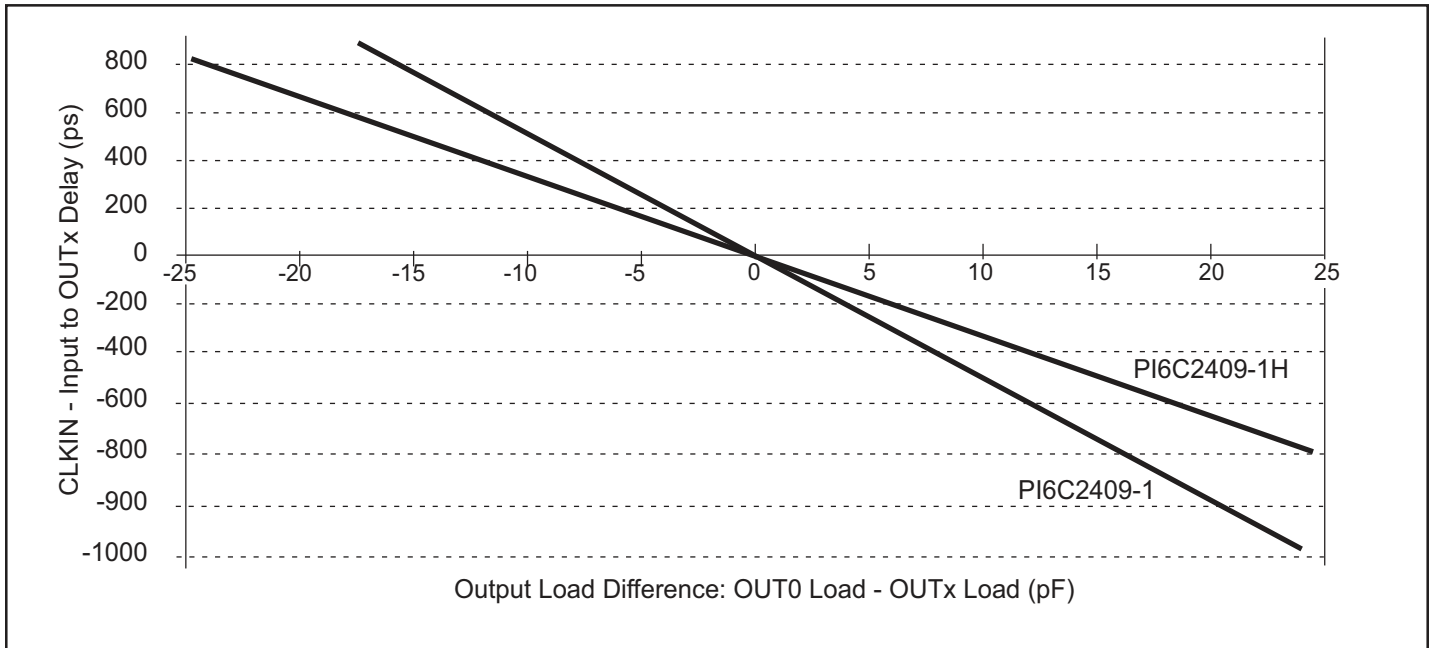

The relationship between loading of the OUT0 signal and other outputs determines the input-output delay. Zero delay is achieved when all outputs, including feedback, are loaded equally.

Maximum Ratings

Supply Voltage to Ground Potential	-0.5V to +7.0V
DC Input Voltage (Except CLKIN)	-0.5V to $V_{DD} + 0.5V$
DC Input Voltage CLKIN	-0.5 to 7V
Storage Temperature	-65°C to +150°C
Maximum Soldering Temperature (10 seconds)	260°C
Junction Temperature	150°C
Static Discharge Voltage (per MIL-STD-883, Method 3015)	>2000V

Operating Conditions ($V_{CC} = 3.3V \pm 0.3V$)

Parameter	Description	Min.	Max.	Units
V_{DD}	Supply Voltage	3.0	3.6	V
T_A	Commerical Operating Temperature	0	70	°C
	Industrial Operating Temperature	-40	85	
C_L	Load Capacitance, below 100 MHz	—	30	pF
	Load Capacitance, from 100 MHz to 133 MHz	—	15	
C_{IN}	Input Capacitance	—	7	

DC Electrical Characteristics for Industrial Temperature Devices

Parameter	Description	Test Conditions	Min.	Max.	Units
V _{IL}	Input LOW Voltage			0.8	V
V _{IH}	Input HIGH Voltage		2.0		
I _{IL}	Input LOW Current	V _{IN} = 0V		50.0	μA
I _{IH}	Input HIGH Current	V _{IN} = V _{DD}		125	
V _{OL}	Output LOW Voltage	I _{OL} = 8mA (-1); I _{OL} = 12mA (-1H)		0.4	V
V _{OH}	Output HIGH Voltage	I _{OH} = -8mA (-1); I _{OH} = -12mA (-1H)	2.4		
I _{DD}	Bypass, PLL OFF	SEL1 = 0, SEL2 = 1		1.0	mA
I _{DD}	Supply Current	Unloaded outputs 100 MHz, Select inputs at V _{DD} or GND		54.0	mA
		Unloaded outputs 66 MHz, CLKIN		39.0	

AC Electrical Characteristics for Industrial Temperature Devices

Parameters	Name	Test Conditions	Min.	Typ.	Max.	Units
F _O	Output Frequency	30pF load (-1, -1H)	10.0		100	MHz
		10pF load, (-1, -1H)			133	
t _{DC}	Duty Cycle ⁽¹⁾ (-1, -1H)	Measured at V _{DD} /2, F _{OUT} = 66.67MHz	40.0	50	60.0	%
	Duty Cycle ⁽¹⁾ (-1H)	Measured at V _{DD} /2V, F _{OUT} <50MHz	45.0		55.0	
t _R	Rise Time ⁽¹⁾ (-1)	Measured between 0.8V and 2.0V			2.5	ns
	Rise Time ⁽¹⁾ (-1H)	Measured between 0.8V and 2.0V			1.5	
t _F	Fall Time ⁽¹⁾ (-1)	Measured between 0.8V and 2.0V			2.5	ns
	Fall Time ⁽¹⁾ (-1H)	Measured between 0.8V and 2.0V			1.5	
t _{SK(O)}	Output to Output Skew (-1, -1H) ⁽¹⁾	All outputs equally loaded			250	ps
t ₀	Delay, CLKIN Rising Edge to OUT0 Rising Edge ⁽¹⁾ (-1, -1H)	Measured at V _{DD} /2		0	±350	
t _{SK(D)}	Device-to-Device Skew ⁽¹⁾ (-1, -1H)	Measured at V _{DD} /2 on OUT0 pins of devices		0	700	
t _{SLEW}	Output Slew Rate ⁽¹⁾ (-1, -1H)	Measured between 0.8V & 2.0V on -1H device using Test Crt #2	1			V/ns
t _{JIT}	Cycle-to-Cycle Jitter ⁽¹⁾ (-1, -1H)	Measured at 66.67 MHz, loaded 30pF load			200	ps
t _{LOCK}	PLL Lock Time ⁽¹⁾ (-1, -1H)	Stable power supply, valid clocks presented on CLKIN pin			1.0	ms

Notes: 1. See Switching Waveforms on page 6.

DC Electrical Characteristics for Commercial Temperature Devices

Parameter	Description	Test Conditions	Min.	Max.	Units
V _{IL}	Input LOW Voltage	—	—	0.8	V
V _{IH}	Input HIGH Voltage	—	2.0	—	
I _{IL}	Input LOW Current	V _{IN} = 0V	—	50	μA
I _{IH}	Input HIGH Current	V _{IN} = V _{DD}	—	125	
V _{OL}	Output LOW Voltage	I _{OL} = 8mA (-1); I _{OL} = 12mA (-1H)	—	0.4	V
V _{OH}	Output HIGH Voltage	I _{OH} = -8mA (-1); I _{OH} = -12mA (-1H)	2.4	—	
I _{DD}	Bypass, PLL off	SEL1 = 0 SEL2 = 1	—	1.0	mA
I _{DD}	Supply Current	Unloaded outputs, 66.67 MHz, Select inputs at V _{DD} or GND	—	39	
I _{DD}	Supply Current	Unloaded outputs 100 MHz Select Inputs @ V _{DD} or GND	—	54	

AC Electrical Characteristics for Commercial Temperature Device

Parameters	Name ¹	Test Conditions	Min.	Typ.	Max.	Units
F _O	Output Frequency	30pF load (-1, -1H)	10		100	MHz
		10pF load, (-1, -1H)			133	
t _{DC}	Duty Cycle (-1H)	Measured at V _{DD} /2, F _O < 50 MHz	45	50	55	%
	Duty Cycle (-1, -1H)	Measured at V _{DD} /2, F _O = 66 MHz	40	50	60	
t _R	Rise Time (-1)	Measured between 0.8V and 2.0V			2.5	ns
	Rise Time (-1H)				1.5	
t _F	Fall Time (-1)				2.5	
	Fall Time (-1H)				1.5	
t _{SK(O)}	Output to Output Skew (-1, -1H)	All outputs equally loaded, V _{DD} /2			250	ps
t ₀	Input to Output Delay, CLKIN Rising Edge to OUT0 Rising Edge (-1, -1H)	Measured at V _{DD} /2		0	±350	
t _{SK(D)}	Device to Device Skew (-1, -1H)	Measured at V _{DD} /2 on OUT0 pins of devices		0	700	
t _{SLEW}	Output Slew Rate (-1, -1H)	Measured between 0.8V and 2.0V on -1H device using Test Circuit #2	1			V/ns
t _{JIT}	Cycle-to-Cycle Jitter (-1, -1H)	Measured at 66.67 MHz, loaded 30pF outputs			200	ps
t _{LOCK}	PLL Lock Time (-1, -1H)	Stable power supply, valid clocks presented on CLKIN pins			1.0	ms

Notes:

1. See Switching Waveforms on page 6

Switching Waveforms

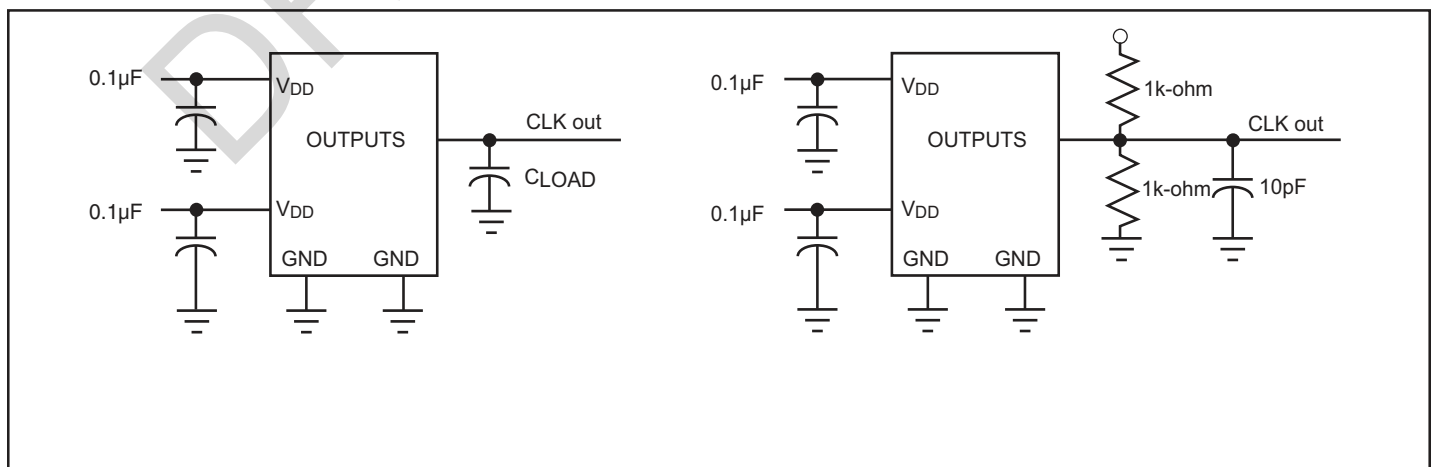
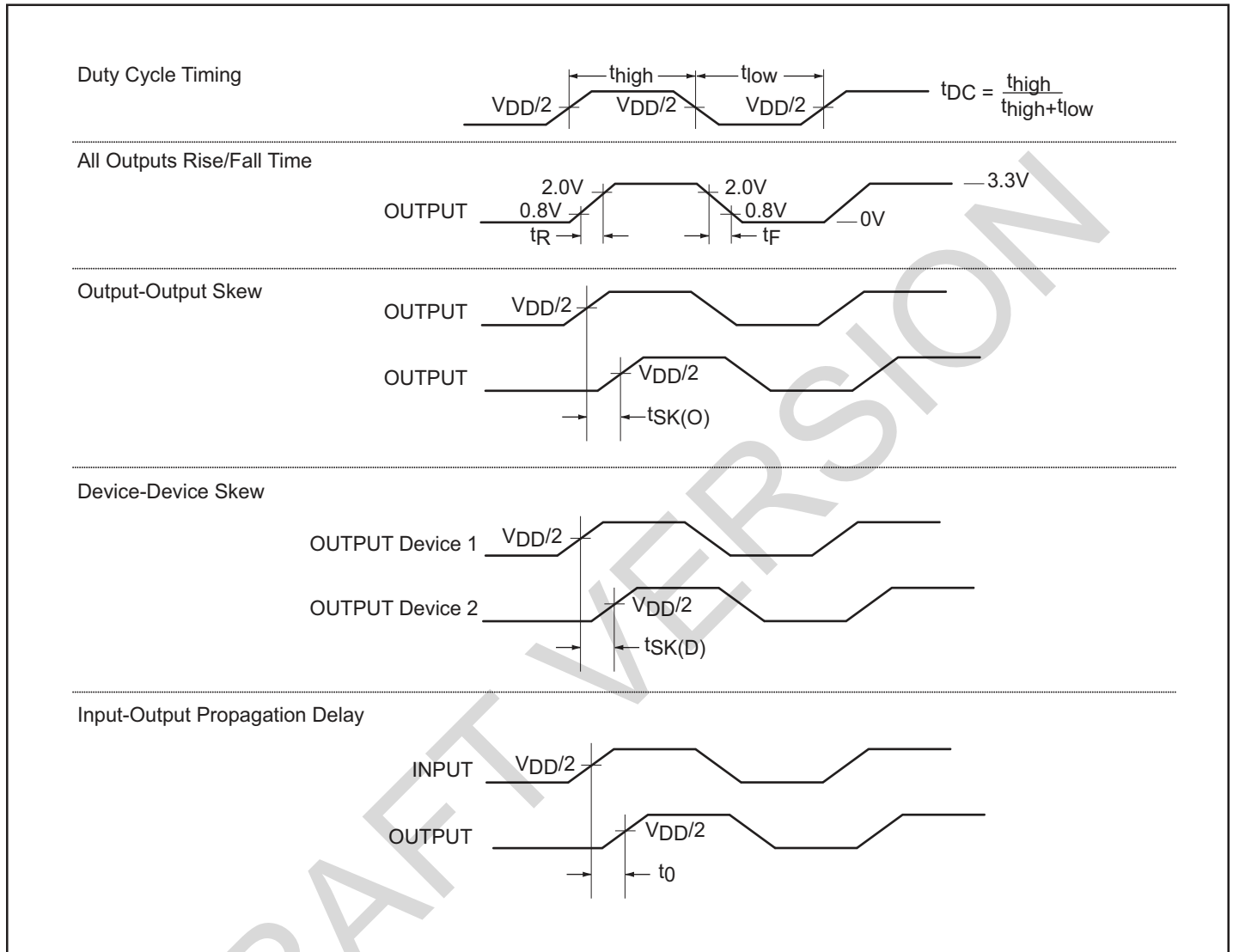

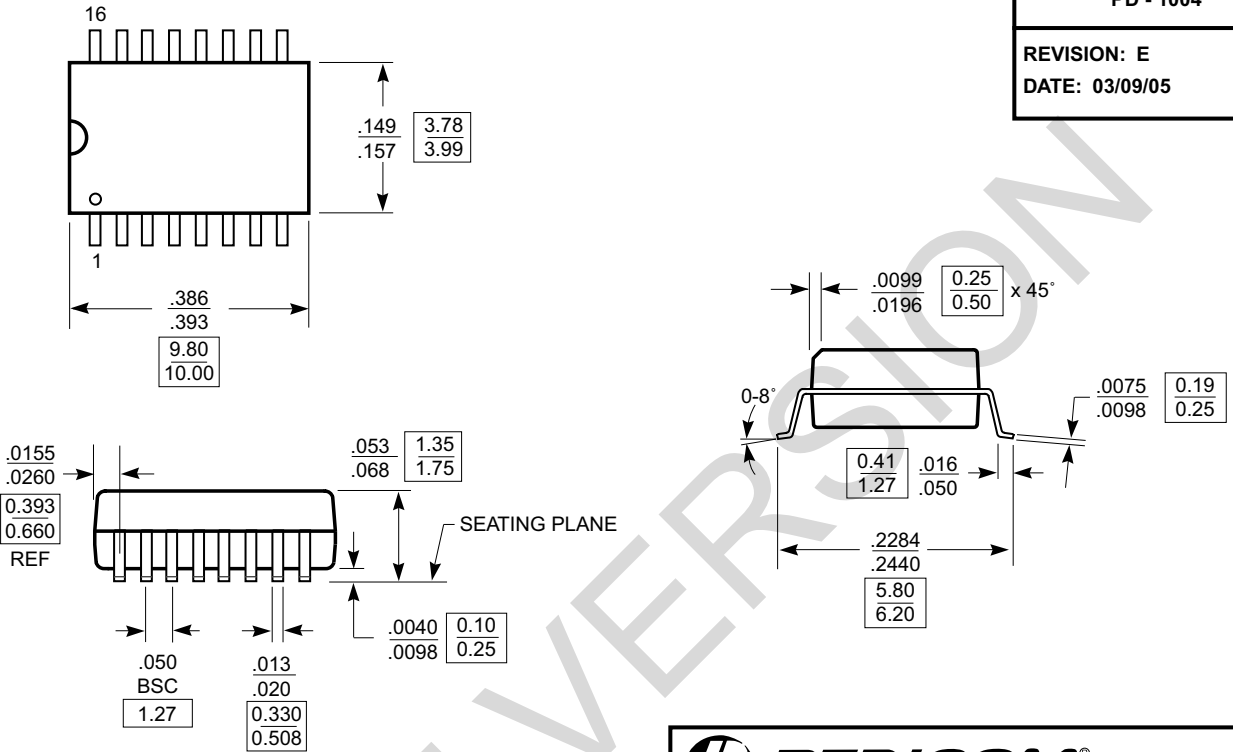
Packaging Mechanical: 16-Pin SOIC (W)
DOCUMENT CONTROL NO.
PD - 1004
REVISION: E
DATE: 03/09/05

X.XX DENOTES DIMENSIONS
 X.XX IN MILLIMETERS

- Notes:
 1) Controlling dimensions in millimeters.
 2) Ref: JEDEC MS-012D/AC

 Pericom Semiconductor Corporation
 3545 N. 1st Street, San Jose, CA 95134
 1-800-435-2335 • www.pericom.com

DESCRIPTION: 16-Pin, 150-Mil Wide, SOIC
PACKAGE CODE: W

Packaging Mechanical: 16-Pin TSSOP (L)

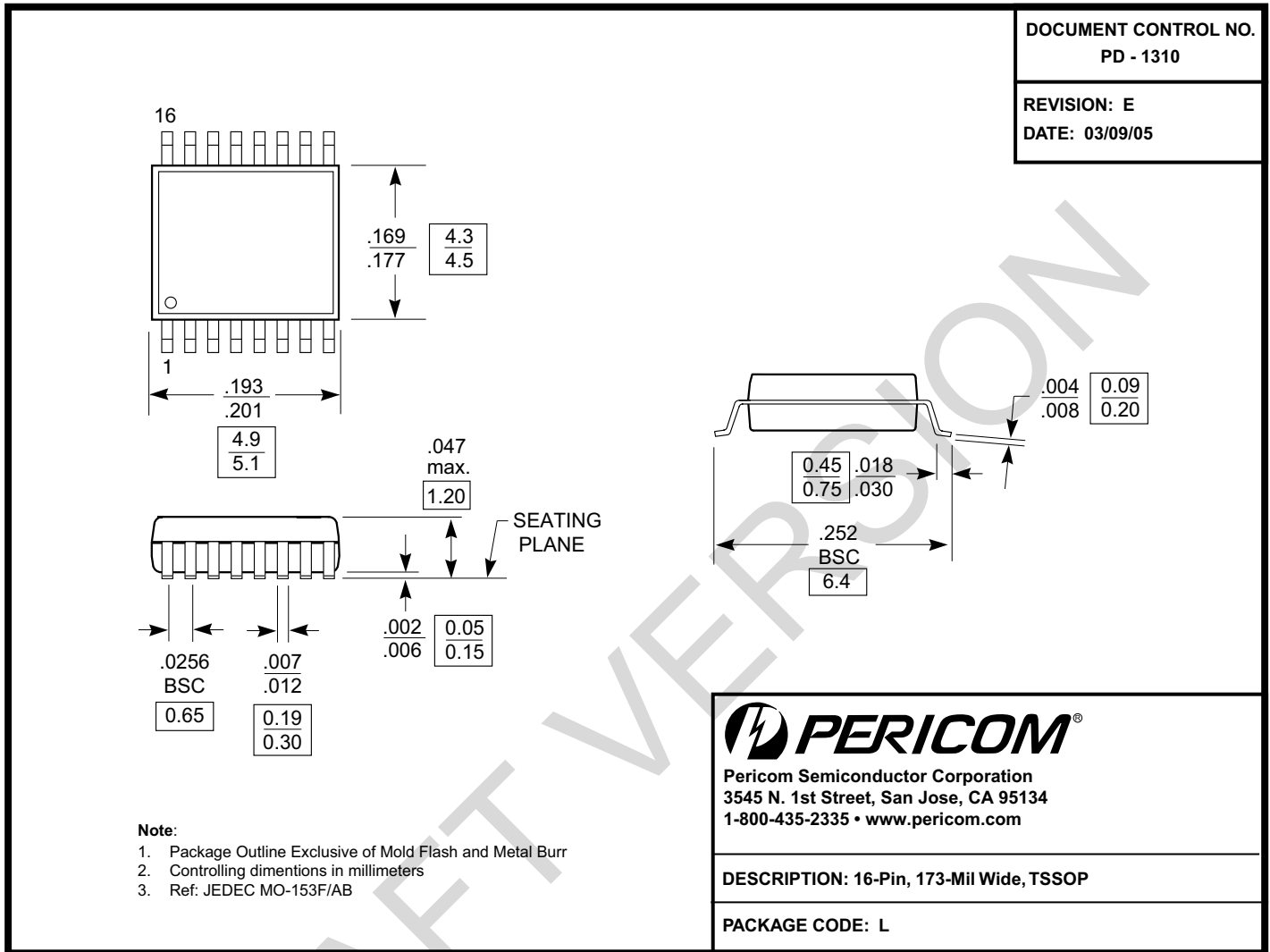

Ordering Information

Ordering Code	Package Code	Package Type	Operating Range
PI6C2409-1WE	W	Pb-free and Green, 16-pin 150-mil SOIC	Commercial
PI6C2409-1HWE	W	Pb-free and Green, 16-pin 150-mil SOIC	Commercial
PI6C2409-1HWIE	W	Pb-free and Green, 16-pin 150-mil SOIC	Industrial
PI6C2409-1LIE	L	Pb-free and Green, 16-pin TSSOP	Industrial
PI6C2409-1HLIE	L	Pb-free and Green, 16-pin TSSOP	Industrial

Notes:

1. Thermal characteristics can be found on the company web site at www.pericom.com/packaging/
2. E = Pb-free and Green
3. Adding an X suffix = Tape/Reel