

REELS PER CARTON	PACKAGING STYLE	PACKAGING MATERIAL NUMBER $\triangle 5$
4	REEL CARTON	885961370

REEL COMPONENT	PACKAGING MATERIAL NUMBER $\triangle 5$	QUANTITY
REEL CORE $\triangle 3$	30907-6481	1
REEL FLANGE	085-06-5024	2
INTERLEAF PAPER	885961467	SEE NOTE 1

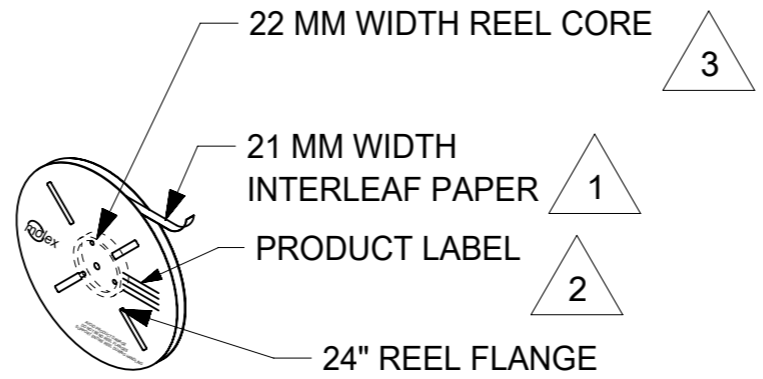

REEL ASSEMBLY
ALL DIMENSION REFERENCE

MATERIAL NUMBER	TERMINALS PER REEL	SPQ
2159530011	12000	48000
2159530021	12000	48000
2159530031	12000	48000
2159530041	10000	40000
2159530012	12000	48000
2159530022	12000	48000
2159530032	12000	48000
2159530042	10000	40000
2159530013	12000	48000
2159530023	12000	48000
2159530033	12000	48000
2159530043	10000	40000

TERMINALS SHOWN WITH BARREL/CRIMPS FACING DOWN

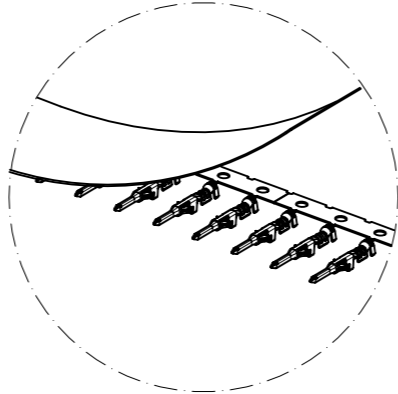
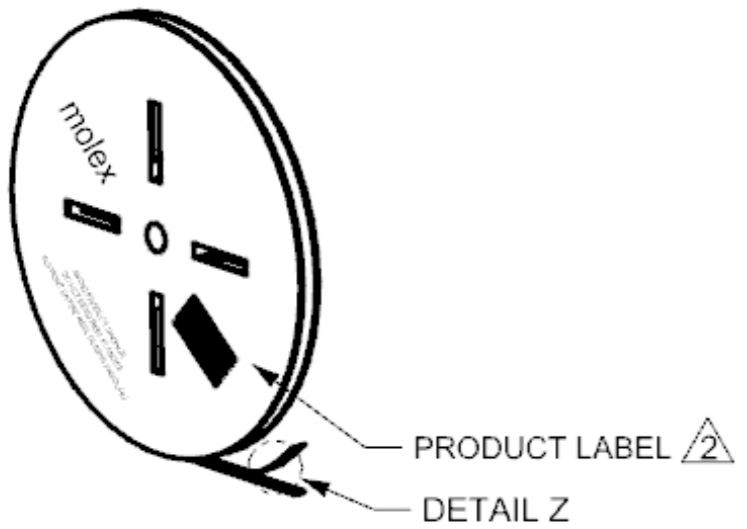

DETAIL Z
TERMINAL ORIENTATION

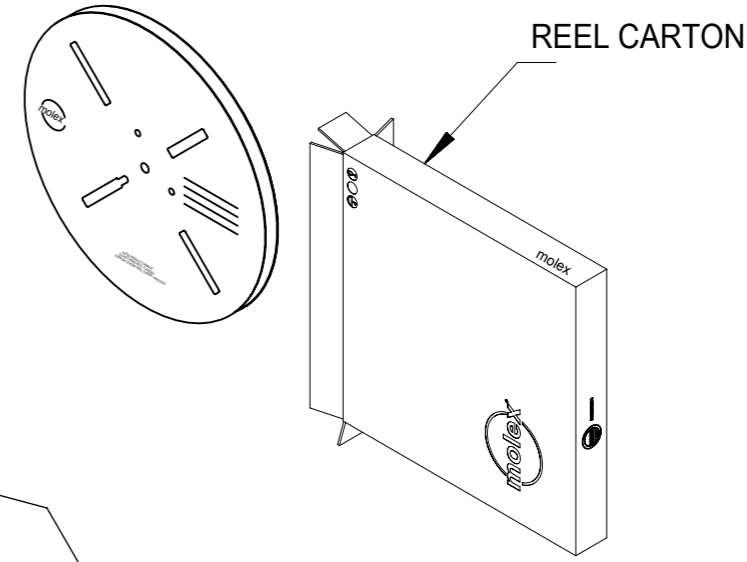

REEL CARTON

- NOTES:
- INTERLEAF PAPER SHOULD BE USED FOR THE ENTIRE REEL. (REF. ES-40000-7005)
 - PRODUCT LABEL TO BE ATTACHED AT THIS APPROXIMATE LOCATION. (REF. ES-40000-7012)
 - REEL CORE IS CUT TO WIDTH AS INDICATED.
 - REELS ARE SHIPPED IN PACKAGING THAT MATCHES PRESCRIBED ORDER QUANTITIES.
 - PREFERRED PACKAGING COMPONENT MATERIAL NUMBERS. ENGINEERING APPROVED EQUIVALENTS MAY BE SUBSTITUTED AS REQUIRED.

FUNCTIONAL SYMBOLS $\nabla A = 0$ $\nabla E = 0$ $\nabla F = 0$	THIS DRAWING CONTAINS INFORMATION THAT IS PROPRIETARY TO MOLEX ELECTRONIC TECHNOLOGIES, LLC AND SHOULD NOT BE USED WITHOUT WRITTEN PERMISSION	CURRENT REV DESC:		molex			
	DIMENSION UNITS: mm	SCALE: 1:1	GENERAL TOLERANCES (UNLESS SPECIFIED)				
DIVISIONAL SYMBOLS	ANGULAR TOL \pm °	EC NO: 683725		PACKAGING DRAWING OF MICRO-FIT WTW TML			
	4 PLACES \pm	DRWN: GLLI 2021/10/28					
	3 PLACES ± 0.1	CHK'D: XQZHANG 2021/11/15		PRODUCT CUSTOMER DRAWING			
	2 PLACES ± 0.3	APPR: XQZHANG 2021/11/15					
	1 PLACE ± 0.5	INITIAL REVISION:		DOCUMENT NUMBER: 2159530000-PK			
0 PLACES \pm	DRWN: GLLI 2021/10/28		DOC TYPE: PSD				DOC PART: 000
DRAFT WHERE APPLICABLE MUST REMAIN WITHIN DIMENSIONS		THIRD ANGLE PROJECTION	DRAWING: A3-SIZE	SERIES: 215953	MATERIAL NUMBER	CUSTOMER	SHEET NUMBER: 1 OF 1

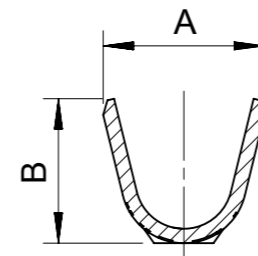
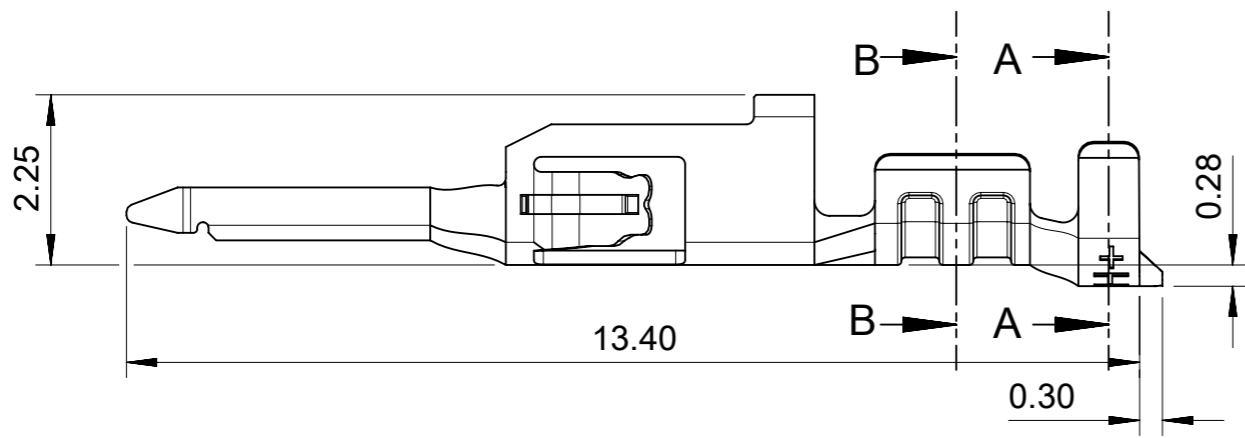

SECTION A-A

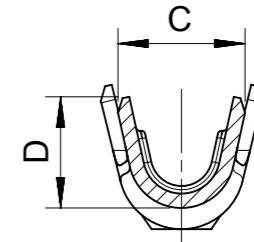

SECTION B-B

OLNY FOR AWG 18~30

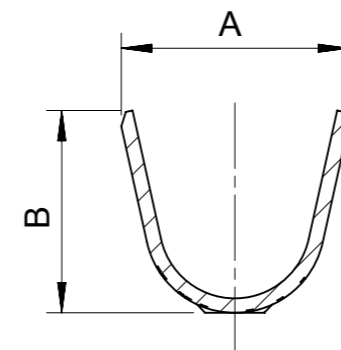
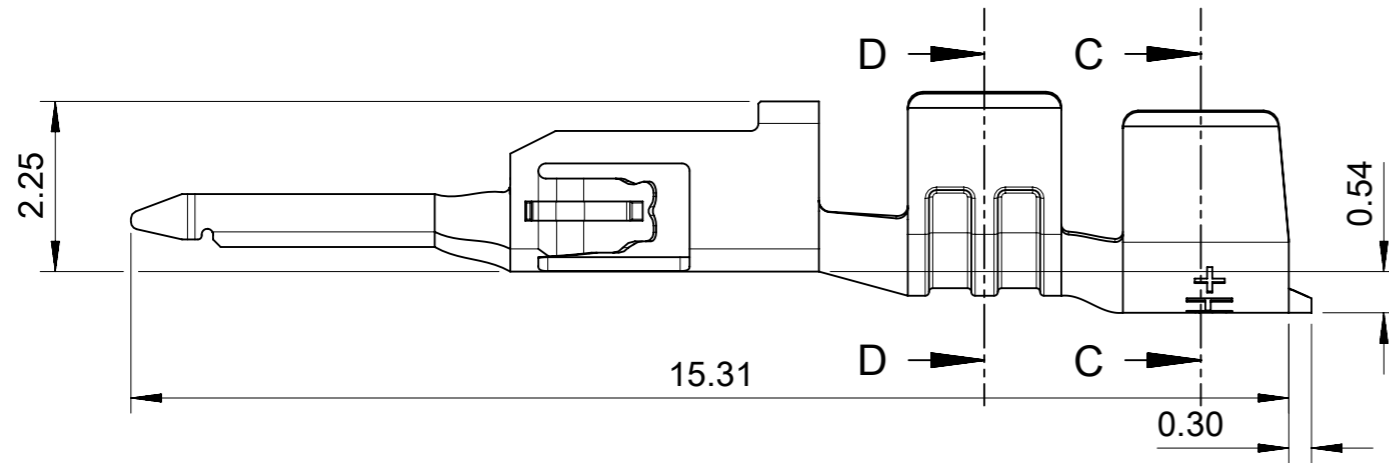

SECTION C-C

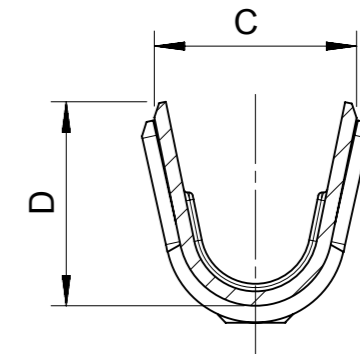

SECTION D-D

OLNY FOR AWG 16

NOTES:

1. MATERIAL: HIGH CONDUCTIVITY COPPER ALLOY.
2. PLATING FINISH SEE CHART IN SHEET 3.
3. PRODUCT SPECIFICATION: 2159530000-PS.
4. PACKAGE SPECIFICATION: 2159530000-PK.
5. PLATING SPEC SEE CHART IN SHEET 3.
7. THIS PART TO BE USED WITH MOLEX PLUG 215922-****
8. PARTS CONFORM TO CLASS 'B' REQUIREMENTS OF COSMETIC SPECIFICATION PS-45499-002.

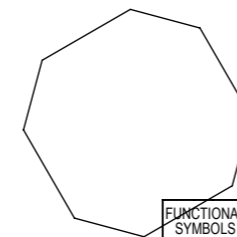

FUNCTIONAL SYMBOLS	THIS DRAWING CONTAINS INFORMATION THAT IS PROPRIETARY TO MOLEX ELECTRONIC TECHNOLOGIES, LLC AND SHOULD NOT BE USED WITHOUT WRITTEN PERMISSION		CURRENT REV DESC:	
	△/A = 0	mm	1:1	
DIVISIONAL SYMBOLS	GENERAL TOLERANCES (UNLESS SPECIFIED)		EC NO: 683725	
	△/E = 0	ANGULAR TOL ± °		DRWN: GLLI 2021/10/27
DIVISIONAL SYMBOLS	△/F = 0	4 PLACES	±	2021/11/15
		3 PLACES	±	0.1
		2 PLACES	±	0.2
		1 PLACE	±	0.3
		0 PLACES	±	
DRAFT WHERE APPLICABLE MUST REMAIN WITHIN DIMENSIONS		THIRD ANGLE PROJECTION	DRAWING	SERIES
			A3-SIZE	215953
		MATERIAL NUMBER		CUSTOMER
		2159530000-SD		GENERAL MARKET
		DOCUMENT NUMBER	DOC TYPE	DOC PART
		2159530000-SD	PSD	000
		REVISION		
		A		
		SHEET NUMBER		
		1 OF 2		

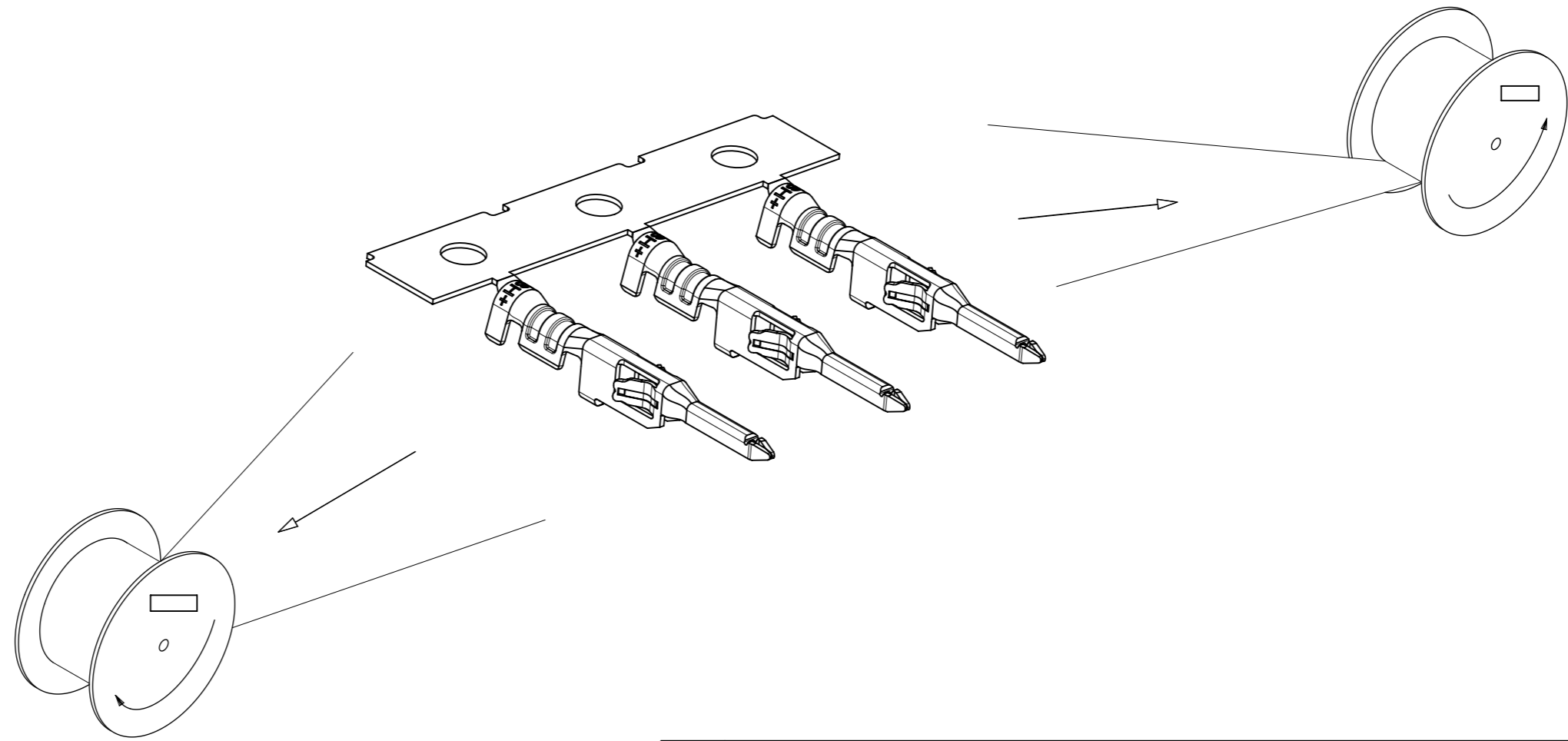

PLATING	
A	REFLOW MATTE TIN OVER ALL(1.5 MICRONS MINIMUM BEFORE REFLOW), UNDER NICKEL PLATING 1.25~2.5 MICRONS MINIMUM OVERALL.
B	GOLD PLATING 0.38 MICRONS MINIMUM ON CONTACT AREA, MATTE TIN PLATING 2.5 MICRONS MINIMUM ON CRIMP AREA, UNDER NICKEL PLATING 1.25~2.5 MICRONS MINIMUM OVERALL.
C	GOLD PLATING 0.76 MICRONS MINIMUM ON CONTACT AREA, MATTE TIN PLATING 2.5 MICRONS MINIMUM ON CRIMP AREA, UNDER NICKEL PLATING 1.25~2.5 MICRONS MINIMUM OVERALL.

PART NUMBER	PLATING	WIRE SIZE	LUBE	DIMENSION			
				A	B	C	D
215953-0011	A	26-30 AWG	YES	2.10	1.91	1.65	1.47
215953-0021	A	20-24 AWG	YES	2.51	2.31	2.08	1.91
215953-0031	A	18 AWG	YES	2.51	2.31	2.39	2.18
215953-0041	A	16 AWG	YES	2.97	2.67	2.70	2.70
215953-0012	B	26-30 AWG	NO	2.10	1.91	1.65	1.47
215953-0022	B	20-24 AWG	NO	2.51	2.31	2.08	1.91
215953-0032	B	18 AWG	NO	2.51	2.31	2.39	2.18
215953-0042	B	16 AWG	NO	2.97	2.67	2.70	2.70
215953-0013	C	26-30 AWG	NO	2.10	1.91	1.65	1.47
215953-0023	C	20-24 AWG	NO	2.51	2.31	2.08	1.91
215953-0033	C	18 AWG	NO	2.51	2.31	2.39	2.18
215953-0043	C	16 AWG	NO	2.97	2.67	2.70	2.70

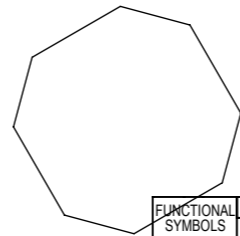

FUNCTIONAL SYMBOLS ▽A = 0 ▽E = 0 ▽F = 0	THIS DRAWING CONTAINS INFORMATION THAT IS PROPRIETARY TO MOLEX ELECTRONIC TECHNOLOGIES, LLC AND SHOULD NOT BE USED WITHOUT WRITTEN PERMISSION	SCALE 1:1	CURRENT REV DESC:		
	DIMENSION UNITS mm	GENERAL TOLERANCES (UNLESS SPECIFIED)			
DIVISIONAL SYMBOLS	ANGULAR TOL ± °		EC NO: 683725		
	4 PLACES ±	3 PLACES ± 0.1	DRWN: GLLI 2021/10/27		
2 PLACES ± 0.2	1 PLACE ± 0.3	CHK'D: XQZHANG 2021/11/15			
0 PLACES ±	INITIAL REVISION:		APP'R: XQZHANG 2021/11/15		
DRAFT WHERE APPLICABLE MUST REMAIN WITHIN DIMENSIONS		THIRD ANGLE PROJECTION	DRAWING	SERIES	DOCUMENT NUMBER
			A3-SIZE	215953	2159530000-SD
			MATERIAL NUMBER	CUSTOMER	DOC TYPE DOC PART REVISION
				GENERAL MARKET	PSD 000 A
				SHEET NUMBER	
				2 OF 2	