

PI6C4911504-01

High Performance LVPECL Fanout Buffer

Features

- 4 LVPECL Outputs
- Up to 1.5GHz Output Frequency
- Ultra Low Additive Phase Jitter: < 0.04 ps (typ)
- Two Selectable Inputs
- Low Delay from Input to Output (Tpd typ. < 1.0ns)
- 2.5V / 3.3V Power Supply
- Industrial Temperature Support
- Totally Lead-Free & Fully RoHS Compliant (Notes 1 & 2)
- Halogen and Antimony Free. “Green” Device (Note 3)
- For automotive applications requiring specific change control (i.e. parts qualified to AEC-Q100/101/200, PPAP capable, and manufactured in IATF 16949 certified facilities), please [contact us](#) or your local Diodes representative.
<https://www.diodes.com/quality/product-definitions/>
- Packaging (Pb-free & Green):
 - 20-Pin, TSSOP (L)

Description

The PI6C4911504-01 is a high performance fanout buffer device which supports up to 1.5GHz frequency. This device is ideal for systems that need to distribute low jitter clock signals to multiple destinations.

Applications

- Networking systems including switches and Routers
- High frequency backplane based computing and telecom platforms

Block Diagram

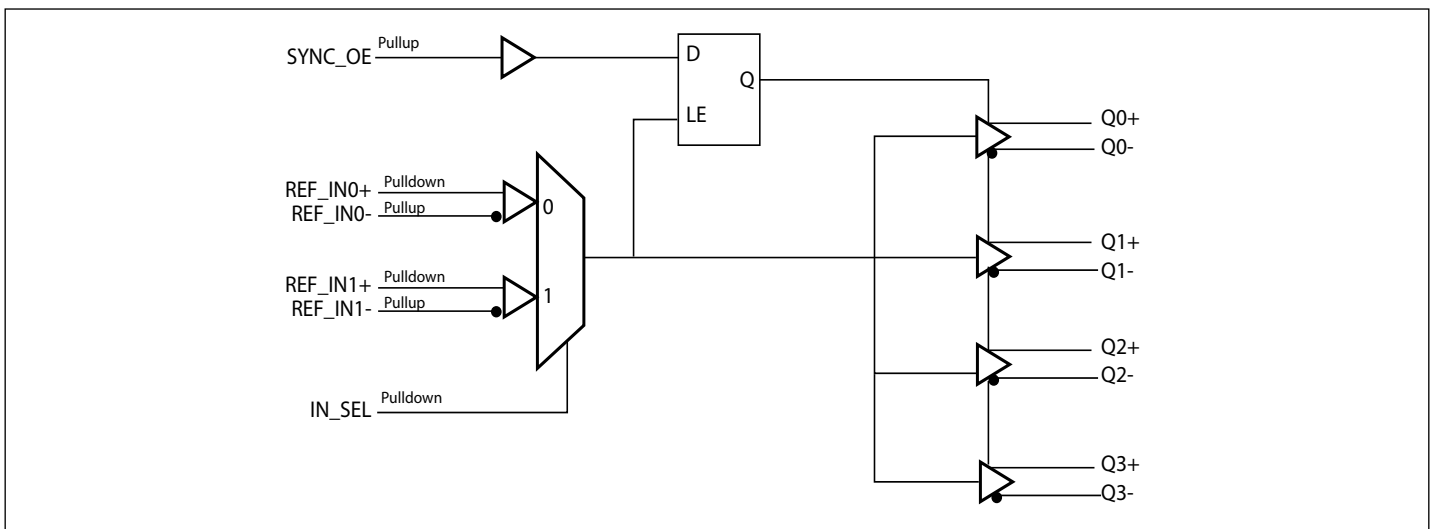

Notes:

1. No purposely added lead. Fully EU Directive 2002/95/EC (RoHS), 2011/65/EU (RoHS 2) & 2015/863/EU (RoHS 3) compliant.
2. See <https://www.diodes.com/quality/lead-free/> for more information about Diodes Incorporated’s definitions of Halogen- and Antimony-free, “Green” and Lead-free.
3. Halogen- and Antimony-free “Green” products are defined as those which contain <900ppm bromine, <900ppm chlorine (<1500ppm total Br + Cl) and <1000ppm antimony compounds.

Pin Configuration

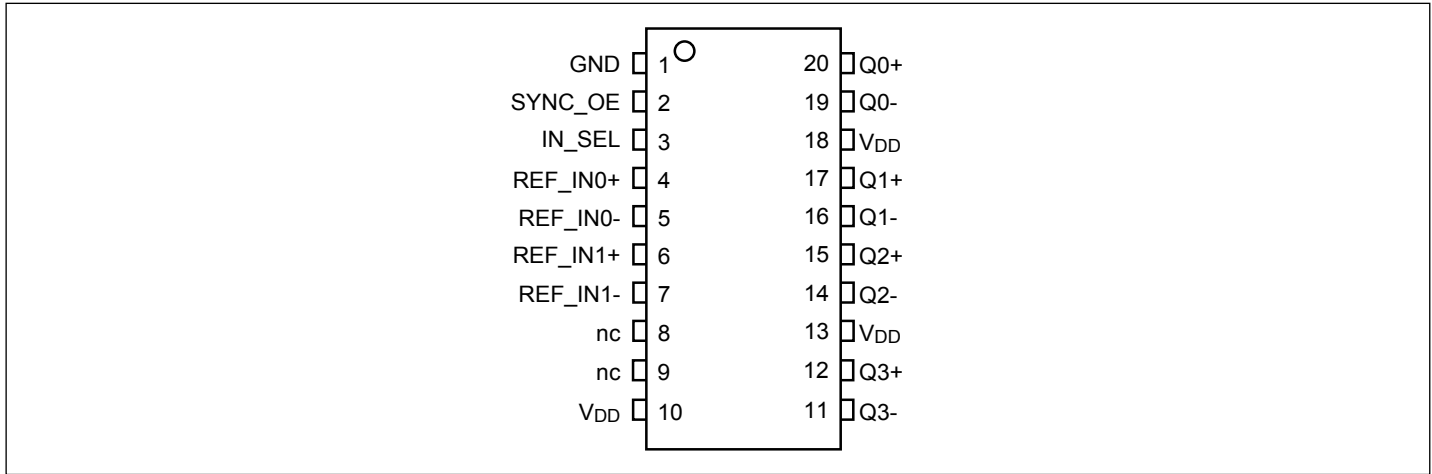

Pin Description

Pin #	Pin Name	Type		Description
1	GND	Power		Ground
2	SYNC_OE	Input	Pullup	Synchronous clock enable. When High, clock outputs follow REF_IN. When low, Q+ outputs are forced low, Q- are forced high
3	IN_SEL	Input	Pulldown	Clock input source selection pin
4, 5	REF_IN0+, REF_IN0-	Input	Pulldown Pullup	Differential clock input 0
6, 7	REF_IN1+, REF_IN1-	Input	Pulldown Pullup	Differential clock input 1
8, 9	NC	-		No connect
10, 13, 18	V _{DD}	Power		Power supply
11, 12	Q3-, Q3+	Output		LVPECL output clock 3
14, 15	Q2-, Q2+	Output		LVPECL output clock 2
16, 17	Q1-, Q1+	Output		LVPECL output clock 1
19, 20	Q0-, Q0+	Output		LVPECL output clock 0

Function Table

Table 1: Clock source input select function

IN_SEL	Function
0	REF_IN0 is the selected reference input
1	REF_IN1 is the selected reference input

Table 2: SYNC_OE select function

SYNC_OE	Function
0	All outputs disabled. Q+ disabled low, Q- disabled High.
1	All outputs enabled.

Pin Characteristics

Symbol	Parameter	Min.	Typ.	Max.	Units
R _{PULLUP}	Input Pullup Resistor		50		kΩ
R _{PULLDOWN}	Input Pulldown Resistor		75		kΩ

Maximum Ratings

(Above which the useful life may be impaired. For user guidelines, not tested)

Storage Temperature.....	-55 to +150°C
Supply Voltage to Ground Potential (V_{DD}).....	-0.5 to +4.65V
Inputs (Referenced to GND)	-0.5 to $V_{DD}+0.5V$
Clock Output (Referenced to GND).....	-0.5 to $V_{DD}+0.5V$
Latch Up	200mA
ESD Protection (Input)	2000 V min (HBM)
Junction Temperature	125°C

Note:

Stresses greater than those listed under MAXIMUM RATINGS may cause permanent damage to the device. This is a stress rating only and functional operation of the device at these or any other conditions above those indicated in the operational sections of this specification is not implied. Exposure to absolute maximum rating conditions for extended periods may affect reliability.

Power Supply Characteristics and Operating Conditions

Symbol	Parameter	Test Condition	Min.	Typ.	Max.	Units
V_{DD}	Supply Voltage		3.135		3.465	V
			2.375		2.625	V
I_{DD}	Power Supply Current	Outputs unloaded			90	mA
T_A	Ambient Operating Temperature		-40		85	°C

LVCMOS/ LVTTL DC Characteristics

Symbol	Parameter	Test Condition	Min.	Typ.	Max.	Units
V_{IH}	Input High Voltage	$V_{DD} = V_{IN} = 3.465V$	2		$V_{DD}+0.3$	V
		$V_{DD} = V_{IN} = 2.625V$	1.6		$V_{DD}+0.3$	V
V_{IL}	Input Low Voltage	$V_{DD} = V_{IN} = 3.465V$	-0.3		0.8	V
		$V_{DD} = V_{IN} = 2.625V$	-0.3		0.6	V
I_{IH}	Input High Current	SYNC_OE	$V_{DD} = V_{IN} = 3.465V$		5	μA
			$V_{DD} = V_{IN} = 2.625V$		5	
		IN_SEL	$V_{DD} = V_{IN} = 3.465V$		150	μA
			$V_{DD} = V_{IN} = 2.625V$		150	
I_{IL}	Input Low Current	SYNC_OE	$V_{DD} = V_{IN} = 3.465V$	-150		μA
			$V_{DD} = V_{IN} = 2.625V$	-150		
		IN_SEL	$V_{DD} = V_{IN} = 3.465V$	-5		μA
			$V_{DD} = V_{IN} = 2.625V$	-5		

DC Electrical Specifications - Differential Inputs

Symbol	Parameter		Min.	Typ.	Max.	Units
I _{IH}	Input High current	REF_IN-	Input = V _{DD}		5	μA
		REF_IN+	Input = V _{DD}		150	μA
I _{IL}	Input Low current	REF_IN-	Input = GND	-150		μA
		REF_IN+	Input = GND	-5		μA
V _{ID}	Input Differential Amplitude (V _{p-p})		0.15		V _{DD} -2.0	V
V _{CM}	Common mode input voltage	REF_IN0	0.5		V _{DD} -0.85	V
		REF_IN1	1.5		V _{DD}	

DC Electrical Specifications- LVPECL Outputs

Parameter	Description	Conditions	Min.	Typ.	Max.	Units
V _{OH}	Output High voltage	V _{DD} = 3.3V ± 5%	V _{DD} -1.4		V _{DD} -0.9	V
		V _{DD} = 2.5V ± 5%	V _{DD} -1.6		V _{DD} -0.8	V
V _{OL}	Output Low voltage	V _{DD} = 3.3V ± 5%	V _{DD} -2.0		V _{DD} -1.6	V
		V _{DD} = 2.5V ± 5%	V _{DD} -2.0		V _{DD} -1.5	V
V _{SWING}	Peak to Peak Output Voltage Swing		0.6		1.0	V

AC Electrical Specifications – Differential Outputs

Parameter	Description	Conditions	Min.	Typ.	Max.	Units
F _{OUT}	Clock output frequency	LVPECL			1500	MHz
T _r	Output rise time	From 20% to 80%	300	400	600	ps
T _f	Output fall time	From 80% to 20%	300	400	600	ps
T _{ODC}	Output duty cycle	Frequency<650MHz	48		52	%
V _{PP}	Output swing Single-ended	Frequency<650MHz	400			
T _{addjitter}	Buffer additive jitter RMS	Using 156.25MHz XO, 0.17ps jitter as source @3.3V		0.05		ps
T _{Phasejitter}	Total output jitter RMS	Using 156.25MHz XO, 0.17ps jitter as source @3.3V		0.23		ps
T _{SK}	Output Skew	4 outputs devices, outputs in same tank, with same load, at DUT.		40		ps
T _{PD}	Propagation Delay			1000		ps
T _{OD}	Valid to HiZ				100	ns
T _{OE}	HiZ to valid				100	ns

Notes:

1. This parameter is guaranteed by design

Phase Noise Plots

$f_{OUT} = 156.25\text{MHz}$

Output phase noise (Dark Blue) vs Input Phase noise (light blue)

Additive jitter is calculated at 156.25MHz~40fs RMS (12kHz to 20MHz). Additive jitter = $\sqrt{(\text{Output jitter}^2 - \text{Input jitter}^2)}$

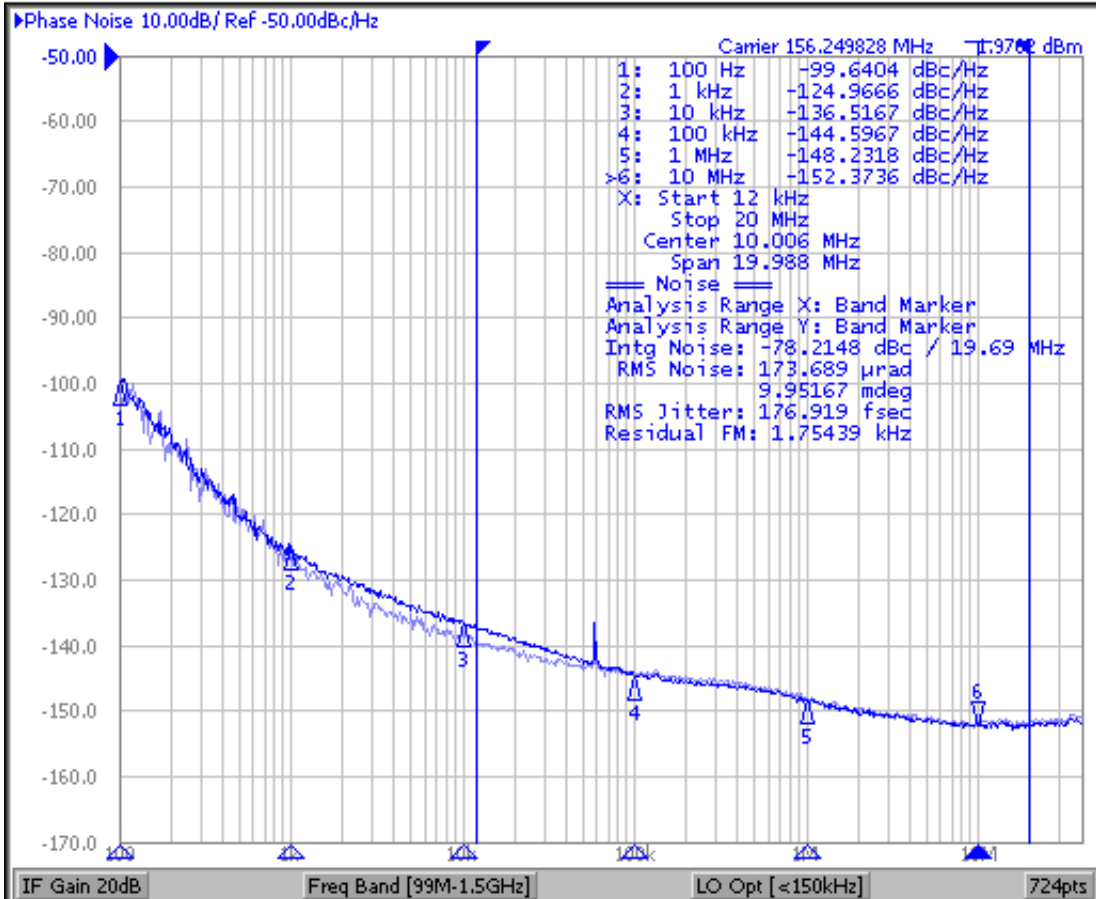

Configuration Test Load Board Termination for LVPECL

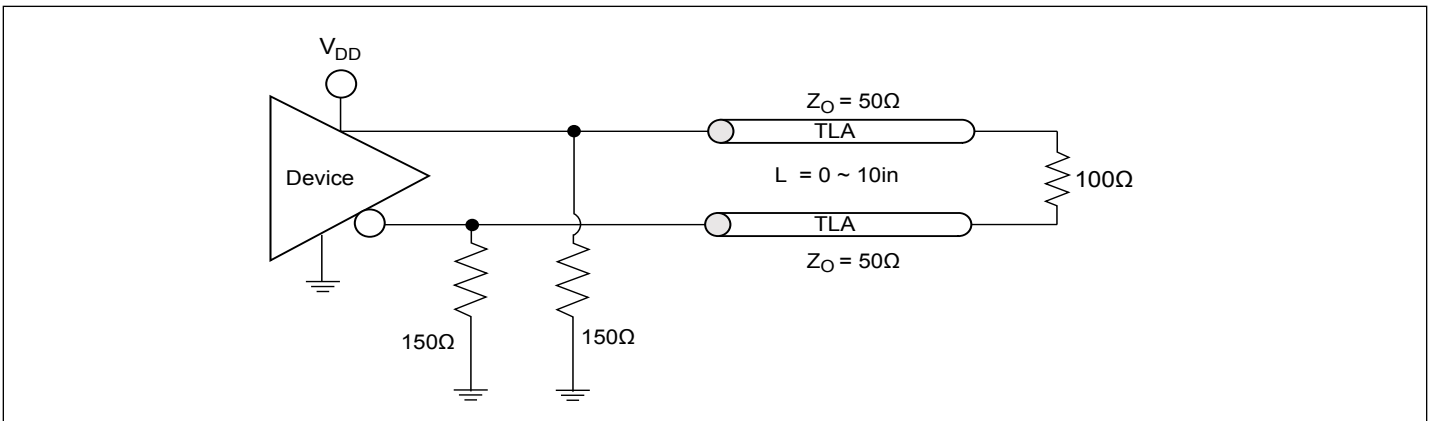

Application Information

Suggest for Unused Inputs and Outputs

LVC MOS Input Control Pins

It is suggested to add pull-up=4.7k and pull-down=1k for LVC MOS pins even though they have internal pull-up/down but with much higher value (>=50k) for higher reliability design.

Differential +IN/-IN Input Pins

They can be left floating if not used. Connect them 1k to GND is optional for the additional protection.

Outputs

All unused outputs are suggested to be left open and not connected to any trace. This can lower the IC power supply power.

Power Decoupling & Routing

VDD Pin Decoupling

As general design rule, each VDD pin must have a 0.1uF decoupling capacitor. For better decoupling, 1uF can be used. Locating the decoupling capacitor on the component side has better decoupling filter result as shown below.

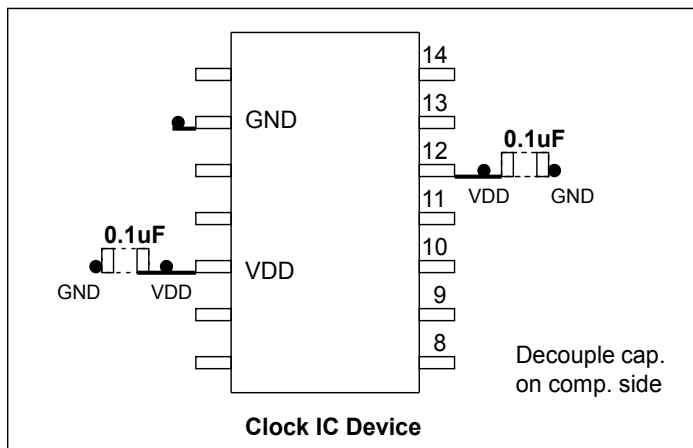

Placement of Decoupling Caps

Differential Clock Trace Routing

Always route differential signals symmetrically, make sure there is enough keep-out space to the adjacent trace (>20mil.). In 156.25MHz XO drives IC example, it is better routing differential trace on component side as the following.

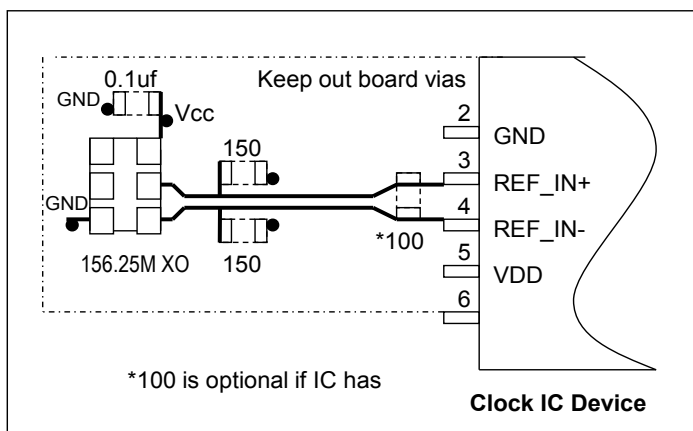

IC Routing for XO Drive

Clock timing is the most important component in PCB design, so its trace routing must be planned and routed as a first priority in manual routing. Some good practices are to use minimum vias (total trace vias count <4), use independent layers with good reference plane and keep other signal traces away from clock traces (>20mil.) etc.

LVPECL and LVDS Input Interface

LVPECL and LVDS DC/ AC Input

LVPECL and LVDS clock input to this IC is connected as shown below.

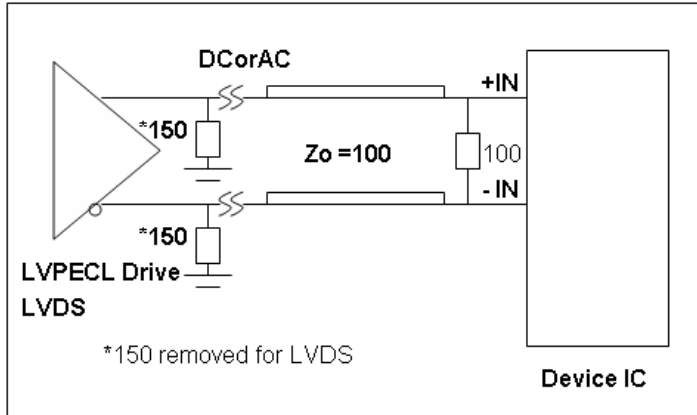

LVPECL/ LVDS Input

CMOS Clock DC Drive Input

LVC MOS clock has voltage V_{oh} levels such as 3.3V, 2.5V, 1.8V. CMOS drive requires a V_{cm} design at the input: $V_{cm} = \frac{1}{2} (CMOS V)$ as shown below. $R_s = 22 \sim 33\Omega$ typically.

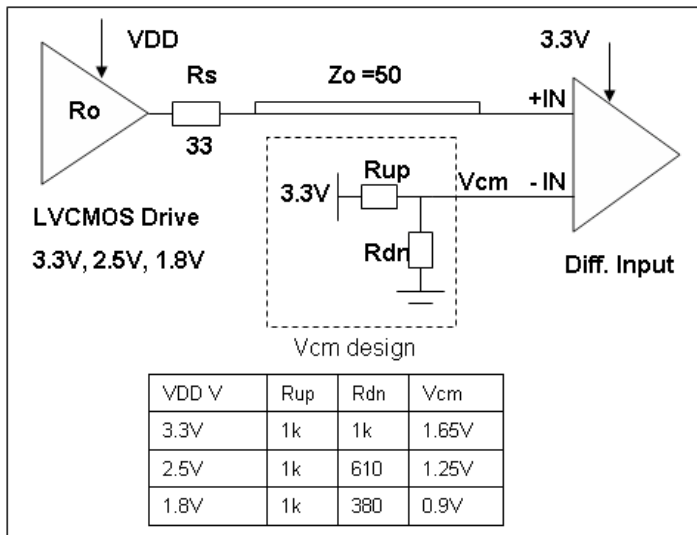

CMOS DC Input Vcm Design

Device LVPECL Output Terminations

LVPECL Output Popular Termination

The most popular LVPECL termination is 150Ω pull-down bias and 100Ω across at RX side. Please consult ASIC datasheet if it already has 100Ω or equivalent internal termination. If so, do not connect external 100Ω across as shown in below. This popular termination's advantage is that it does not allow any bias through from Vcc. This prevents Vcc system noise coupling onto clock trace.

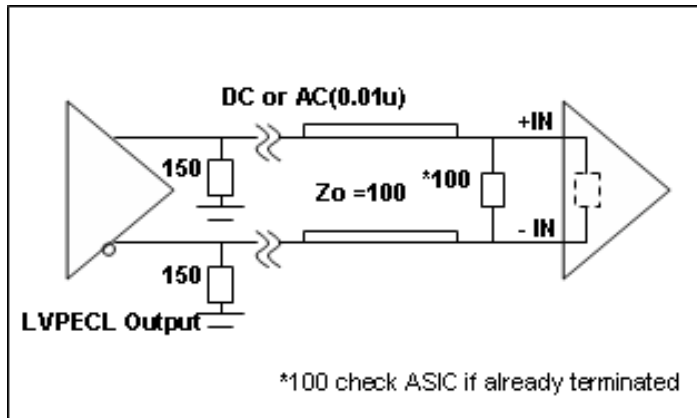

LVPECL Output Popular Termination

LVPECL Output Thevenin Termination

Figure below shows LVPECL output Thevenin termination which is used for shorter trace drive (<5in.), but it takes Vcc bias current and Vcc noise can get onto clock trace. It also requires more component count. So it is seldom used today.

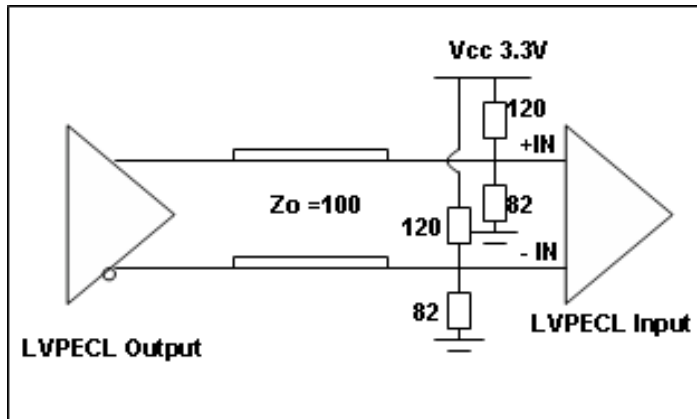

LVPECL Thevenin Output Termination

LVPECL Output AC Thevenin Termination

LVPECL AC Thevenin terminations require a 150Ω pull-down before the AC coupling capacitor at the source as shown below. Note that pull-up/down resistor value is swapped compared to previous figure. This circuit is good for short trace (<5in.) application only.

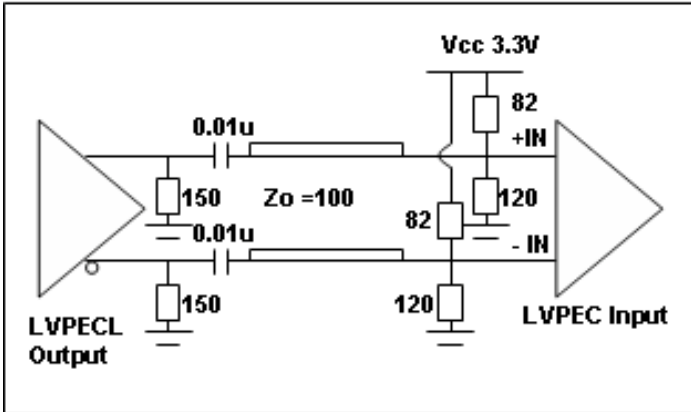

LVPECL Output AC Thenvenin Termination

LVPECL Output Drive HCSL Input

Using the LVPECL output to drive a HCSL input can be done using a typical LVPECL AC Thenvenin termination scheme. Use pull-up/down 450/60Ω to generate $V_{cm}=0.4V$ for the HCSL input clock. This termination is equivalent to 50Ω load as shown.

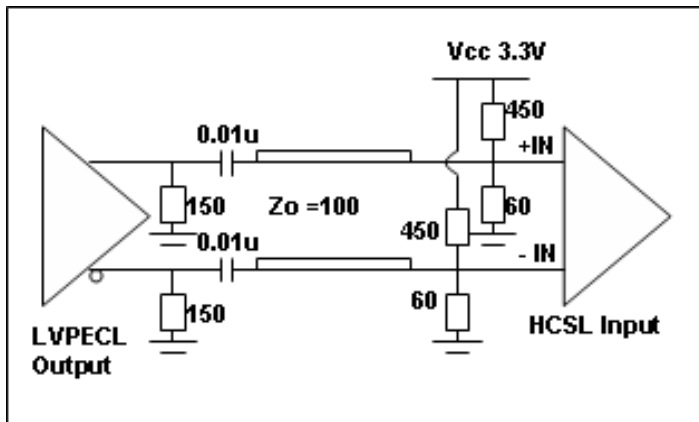

LVPECL Output Drive HCSL Termination

LVPECL Output V_{swing} Adjustment

It is suggested to add another cross 100Ω at TX side to tune the LVPECL output V_{swing} without changing the optimal 150Ω pull-down bias. This form of double termination can reduce the V_{swing} in ½ of the original at the RX side. By fine tuning the 100Ω resistor at the TX side with larger values like 150 to 200Ω, one can increase the V_{swing} by > 1/2 ratio.

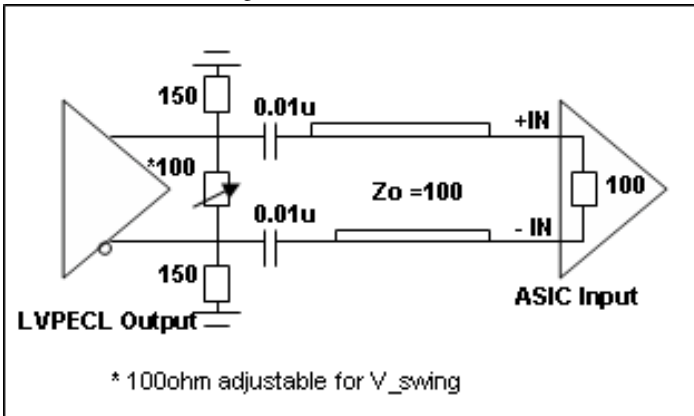

LVPECL Output V_{swing} Adjustment

LVPECL V_{Swing} Adjustment using Rs

Another way to control V_{swing} is by adding serial Rs. Rs value is tunable between 22 to 33Ω depending on application. This method may reduce the clock drive PCB trace in slower Tr/Tf.

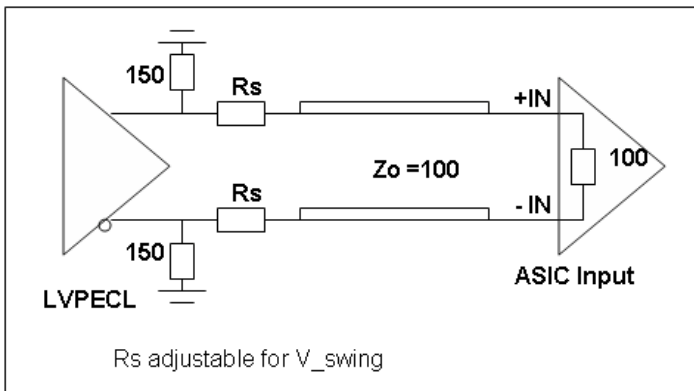

LVPECL V_{swing} Adjustment using Rs

Clock Jitter Definitions

Total jitter= RJ + DJ

Random Jitter (RJ) is unpredictable and unbounded timing noise that can fit in a Gaussian math distribution in RMS. RJ test values are directly related with how long or how many test samples are available. Deterministic Jitter (DJ) is timing jitter that is predictable and periodic in fixed interference frequency. Total Jitter (TJ) is the combination of random jitter and deterministic jitter: , where is a factor based on total test sample count. JEDEC std. specifies digital clock TJ in 10k random samples.

Phase Jitter

Phase noise is short-term random noise attached on the clock carrier and it is a function of the clock offset from the carrier, for example dBc/Hz@10kHz which is phase noise power in 1-Hz normalized bandwidth vs. the carrier power @10kHz offset. Integration of phase noise in plot over a given frequency band yields RMS phase jitter, for example, to specify phase jitter <=1ps at 12k to 20MHz offset band as SONET standard specification.

PCIe Ref_CLK Jitter

PCIe reference clock jitter specification requires testing via the PCI-SIG jitter tool, which is regulated by US PCI-SIG organization. The jitter tool has PCIe Serdes embedded filter to calculate the equivalent jitter that relates to data link eye closure. Direct peak-peak jitter or phase jitter test data, normally is higher than jitter measure using PCI-SIG jitter tool. It has high-frequency jitter and low-frequency jitter spec. limit. For more information, please refer to the PCI-SIG website: <http://www.pcisig.com/specifications/pciexpress/>

Device Thermal Calculation

Figure below shows the JEDEC thermal model in a 4-layer PCB.

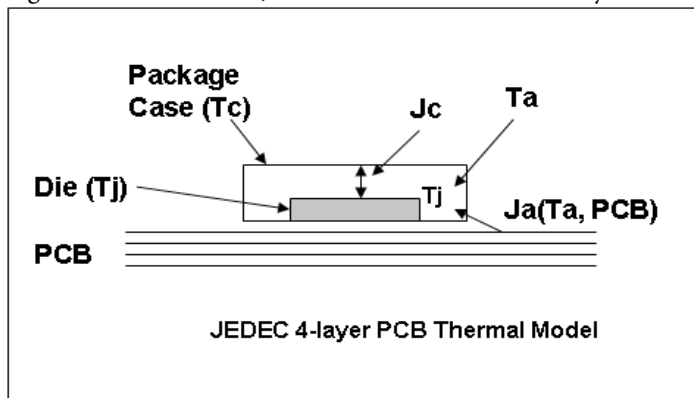

JEDEC IC Thermal Model

Important factors to influence device operating temperature are:

- 1) The power dissipation from the chip (P_chip) is after subtracting power dissipation from external loads. Generally it can be the no-load device Idd
- 2) Package type and PCB stack-up structure, for example, 1oz 4 layer board. PCB with more layers and are thicker has better heat dissipation
- 3) Chassis air flow and cooling mechanism. More air flow M/s and adding heat sink on device can reduce device final die junction temperature Tj

The individual device thermal calculation formula:

$$T_j = T_a + P_{chip} \times J_a$$

$$T_c = T_j - P_{chip} \times J_c$$

Ja ___ Package thermal resistance from die to the ambient air in C/W unit; This data is provided in JEDEC model simulation. An air flow of 1m/s will reduce Ja (still air) by 20~30%

Jc ___ Package thermal resistance from die to the package case in C/W unit

Tj ___ Die junction temperature in C (industry limit <125C max.)

Ta ___ Ambient air temperature in C

Tc ___ Package case temperature in C

Pchip___ IC actually consumes power through Iee/GND current

Thermal calculation example

To calculate Tj and Tc of PI6CV304 in an SOIC-8 package:

Step 1: Go to Diodes web to find Ja=157 C/W, Jc=42 C/W

<https://www.diodes.com/design/support/packaging/pericom-packaging/packaging-mechanicals-and-thermal-characteristics/>

Step 2: Go to device datasheet to find Idd=40mA max.

I _{DD}	Supply Current	C _L = 33pF/33MHz	20	mA
		C _L = 33pF/66MHz	40	
		C _L = 22pF/80MHz	35	
		C _L = 15pF/100MHz	32	
		C _L = 10pF/125MHz	28	
		C _L = 10pF/155MHz	41	

Step 3: P_{total} = 3.3Vx40mA=0.132W

Step 4: If Ta=85C

$$T_j = 85 + J_a \times P_{total} = 85 + 25.9 = 105.7C$$

$$T_c = T_j + J_c \times P_{total} = 105.7 - 5.54 = 100.1C$$

Note:

The above calculation is directly using Idd current without subtracting the load power, so it is a conservative estimation. For more precise thermal calculation, use P_{unload} or P_{chip} from device I_{ee} or GND current to calculate Tj, especially for LVPECL buffer ICs that have a 150Ω pull-down and equivalent 100Ω differential RX load.

Thermal Information

Symbol	Description	Condition	
Θ _{JA}	Junction-to-ambient thermal resistance	Still air	84.0 °C/W
Θ _{JC}	Junction-to-case thermal resistance		17.0 °C/W

Part Marking

PI6C4911
504-01LIE
YYWWXX̄

○

YY: Year
WW: Workweek
1st X: Assembly Code
2nd X: Fab Code

Packaging Mechanical

20-TSSOP (L)

SYMBOLS	MIN.	NOM.	MAX.
A	–	–	1.20
A1	0.05	–	0.15
A2	0.80	1.00	1.05
b	0.19	–	0.30
C	0.09	–	0.20
D	6.40	6.50	6.60
E1	4.30	4.40	4.50
E	6.20	6.40	6.60
e	0.65 BSC		
L1	1.00 REF		
L	0.45	0.60	0.75
S	0.20	–	–
θ	0°	–	8°

NOTES:
 1. ALL DIMENSIONS IN MILLIMETERS. ANGLES IN DEGREES.
 2. JEDEC MO-153F
 3. DIMENSIONS DOES NOT INCLUDE MOLD FLASH, PROTRUSIONS OR GATE BURRS.

PERICOM
Enabling Serial Connectivity

DATE: 03/31/16

DESCRIPTION: 20-Pin, 173mil Wide TSSOP
 PACKAGE CODE: L (L20)
 DOCUMENT CONTROL #: PD-1311 REVISION: G

16-0074

For latest package info.

please check: <http://www.diodes.com/design/support/packaging/pericom-packaging/packaging-mechanicals-and-thermal-characteristics/>

Ordering Information

Ordering Number	Package Code	Package Description	Operating Temperature
PI6C4911504-01LIEX	L	20-Pin, 173mil Wide (TSSOP)	-40 to 85 °C

Notes:

1. No purposely added lead. Fully EU Directive 2002/95/EC (RoHS), 2011/65/EU (RoHS 2) & 2015/863/EU (RoHS 3) compliant.
2. See <https://www.diodes.com/quality/lead-free/> for more information about Diodes Incorporated's definitions of Halogen- and Antimony-free, "Green" and Lead-free.
3. Halogen- and Antimony-free "Green" products are defined as those which contain <900ppm bromine, <900ppm chlorine (<1500ppm total Br + Cl) and <1000ppm antimony compounds.
4. I = Industrial
5. E = Pb-free and Green
6. X suffix = Tape/Reel

IMPORTANT NOTICE

1. DIODES INCORPORATED AND ITS SUBSIDIARIES (“DIODES”) MAKE NO WARRANTY OF ANY KIND, EXPRESS OR IMPLIED, WITH REGARDS TO ANY INFORMATION CONTAINED IN THIS DOCUMENT, INCLUDING, BUT NOT LIMITED TO, THE IMPLIED WARRANTIES OF MERCHANTABILITY, FITNESS FOR A PARTICULAR PURPOSE OR NON-INFRINGEMENT OF THIRD PARTY INTELLECTUAL PROPERTY RIGHTS (AND THEIR EQUIVALENTS UNDER THE LAWS OF ANY JURISDICTION).

2. The Information contained herein is for informational purpose only and is provided only to illustrate the operation of Diodes products described herein and application examples. Diodes does not assume any liability arising out of the application or use of this document or any product described herein. This document is intended for skilled and technically trained engineering customers and users who design with Diodes products. Diodes products may be used to facilitate safety-related applications; however, in all instances customers and users are responsible for (a) selecting the appropriate Diodes products for their applications, (b) evaluating the suitability of the Diodes products for their intended applications, (c) ensuring their applications, which incorporate Diodes products, comply the applicable legal and regulatory requirements as well as safety and functional-safety related standards, and (d) ensuring they design with appropriate safeguards (including testing, validation, quality control techniques, redundancy, malfunction prevention, and appropriate treatment for aging degradation) to minimize the risks associated with their applications.

3. Diodes assumes no liability for any application-related information, support, assistance or feedback that may be provided by Diodes from time to time. Any customer or user of this document or products described herein will assume all risks and liabilities associated with such use, and will hold Diodes and all companies whose products are represented herein or on Diodes’ websites, harmless against all damages and liabilities.

4. Products described herein may be covered by one or more United States, international or foreign patents and pending patent applications. Product names and markings noted herein may also be covered by one or more United States, international or foreign trademarks and trademark applications. Diodes does not convey any license under any of its intellectual property rights or the rights of any third parties (including third parties whose products and services may be described in this document or on Diodes’ website) under this document.

5. Diodes products are provided subject to Diodes’ Standard Terms and Conditions of Sale (<https://www.diodes.com/about/company/terms-and-conditions/terms-and-conditions-of-sales/>) or other applicable terms. This document does not alter or expand the applicable warranties provided by Diodes. Diodes does not warrant or accept any liability whatsoever in respect of any products purchased through unauthorized sales channel.

6. Diodes products and technology may not be used for or incorporated into any products or systems whose manufacture, use or sale is prohibited under any applicable laws and regulations. Should customers or users use Diodes products in contravention of any applicable laws or regulations, or for any unintended or unauthorized application, customers and users will (a) be solely responsible for any damages, losses or penalties arising in connection therewith or as a result thereof, and (b) indemnify and hold Diodes and its representatives and agents harmless against any and all claims, damages, expenses, and attorney fees arising out of, directly or indirectly, any claim relating to any noncompliance with the applicable laws and regulations, as well as any unintended or unauthorized application.

7. While efforts have been made to ensure the information contained in this document is accurate, complete and current, it may contain technical inaccuracies, omissions and typographical errors. Diodes does not warrant that information contained in this document is error-free and Diodes is under no obligation to update or otherwise correct this information. Notwithstanding the foregoing, Diodes reserves the right to make modifications, enhancements, improvements, corrections or other changes without further notice to this document and any product described herein. This document is written in English but may be translated into multiple languages for reference. Only the English version of this document is the final and determinative format released by Diodes.

8. Any unauthorized copying, modification, distribution, transmission, display or other use of this document (or any portion hereof) is prohibited. Diodes assumes no responsibility for any losses incurred by the customers or users or any third parties arising from any such unauthorized use.

Copyright © 2021 Diodes Incorporated

www.diodes.com