

PART NUMBER TABLE			
DIM "L"	DIALIGHT PART NUMBER	DIM "L"	DIALIGHT PART NUMBER
10 mm	515-1141-100F	18 mm	—
10.5 mm	—	18.5 mm	—
11 mm	—	19 mm	—
11.5 mm	—	19.5 mm	515-1141-195F
12 mm	—	20 mm	—
12.5 mm	—	20.5 mm	—
13 mm	—	21 mm	—
13.5 mm	—	21.5 mm	—
14 mm	—	22 mm	515-1141-220F
14.5 mm	—	22.5 mm	—
15 mm	—	23 mm	—
15.5 mm	—	23.5 mm	—
16 mm	—	24 mm	—
16.5 mm	—	24.5 mm	—
17 mm	—	25 mm	515-1141-250F
17.5 mm	—	—	—

NOTES:

- LIGHT PIPE TO BE MOLDED IN A CLEAR, TRANSMISSIVE, UL 94-V0 POLYCARBONATE.
- LIGHT PIPE TO BE PRESSED INTO A .062 OR .093 THICK P.C. BOARD.
- LIGHT SOURCE: PLCC-2, PLCC-4 SMT LED OR EQUIVALENT.
597-3604-307F, BLUE 470nm
597-3323-307F, GREEN 525nm
597-3225-307F, YELLOW 590nm
597-3904-307F, WHITE
- * DENOTES CRITICAL DIMENSION OR SPECIFICATION.
- VARIABLE LENGTH LIGHT PIPE FROM 10mm MINIMUM TO 25mm MAXIMUM, BASIC PART NUMBER IS 515-1141-XXF
EXACT LIGHT PIPE PART NUMBER TO BE DETERMINED BY LENGTH IN mm (DIMENSION "L").
LENGTHS MUST BE IN 0.5mm INCREMENTS. SEE CHART FOR EXACT PART NUMBERS.
- EACH DIFFERENT LENGTH REQUIRES AN ADDITIONAL CORE PIN TOOLING CHARGE.

REV	ECN NO	REVISIONS	DRN	CKD	APP	DATE
A	—	NEW RELEASE	TWC	N.O.	AV	5-11-05
B	—	REVISED TITLE BLOCK; MOVED DRAWING NUMBER; REPLACED DOMED FEATURE ON OUTPUT SURFACE WITH Ø.067 X .010 FEATURE; CORRECTED NOTES	TWC	TC	N.O.	6-3-05
C	—	ADDED "F" SUFFIX TO P/N FOR RoHS COMPLIANT DESIGNATION; REMOVED P/Ns NOT TOOLED; ADDED "L" DIM IN DWG FIELD	TWC			

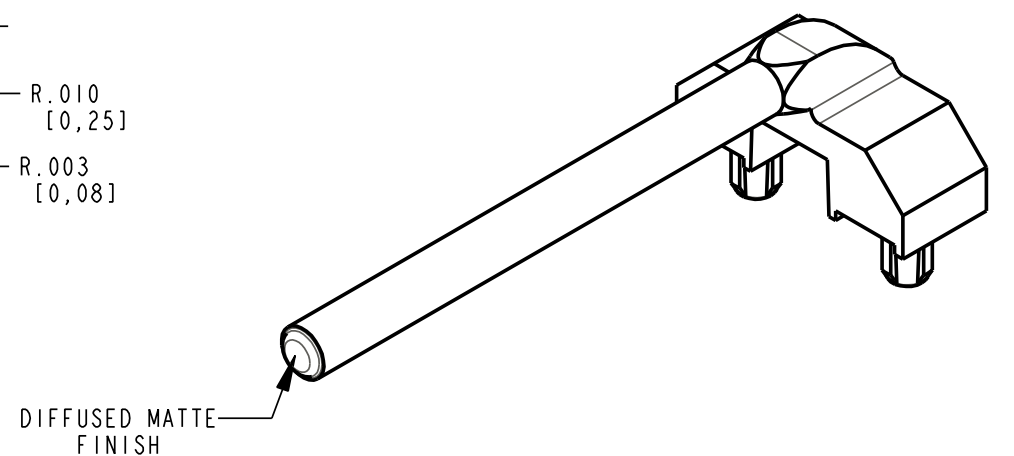
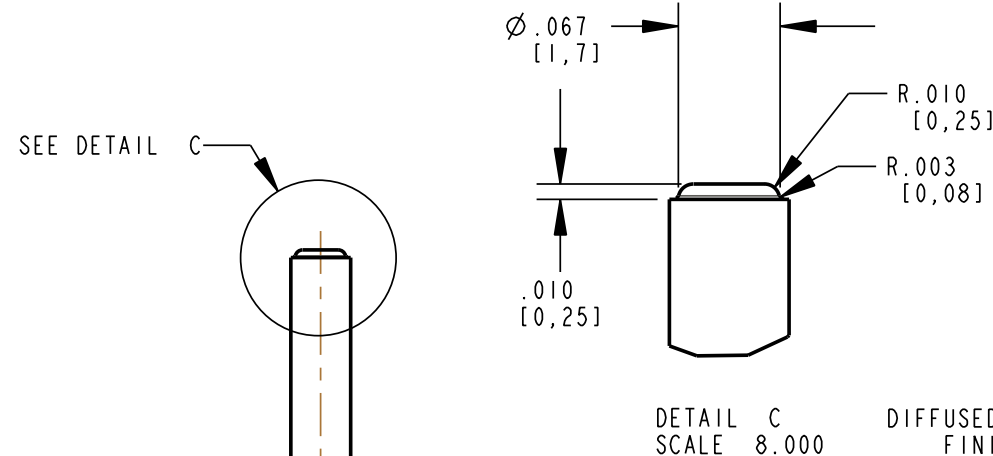
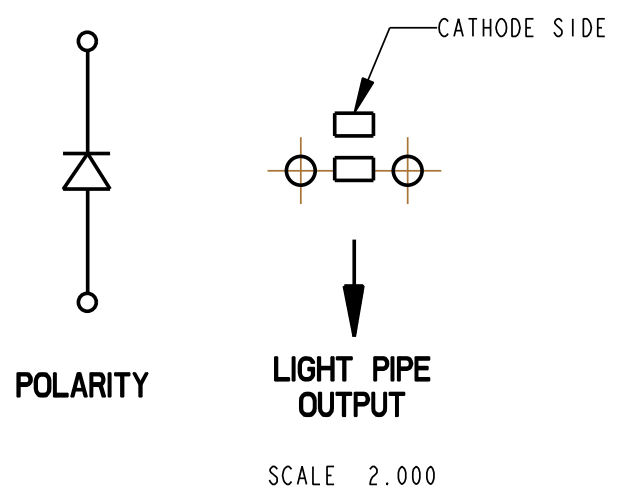
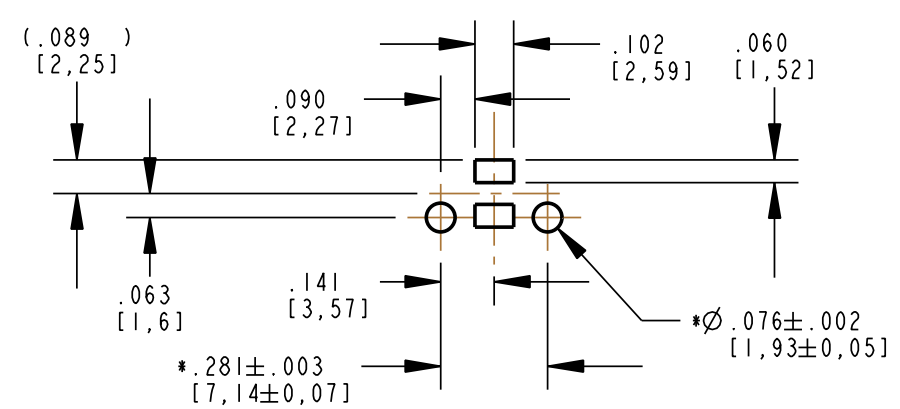
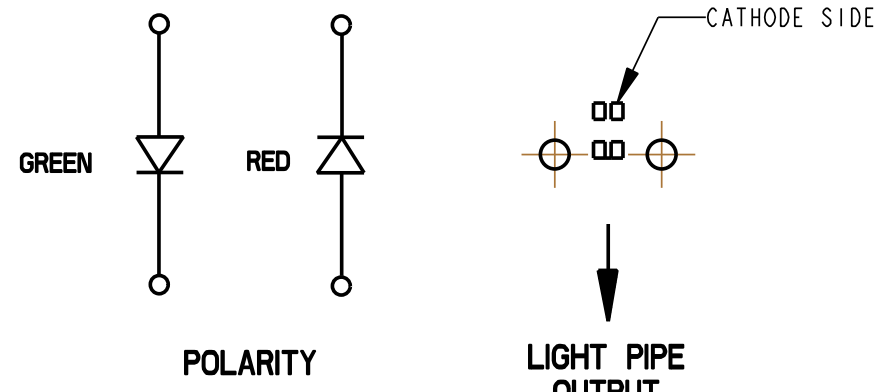
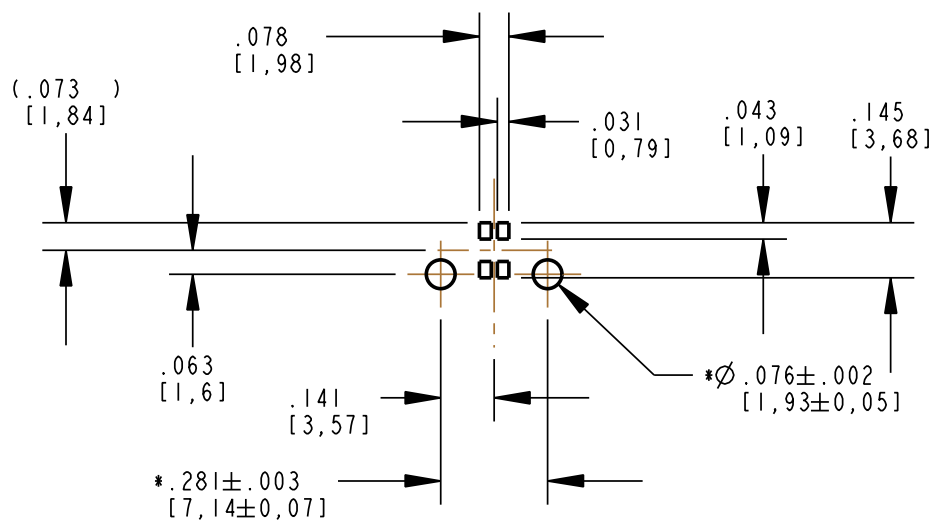
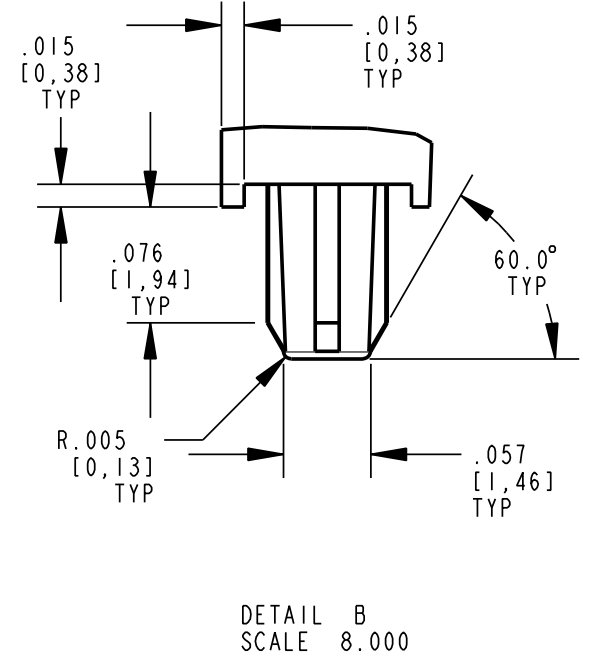
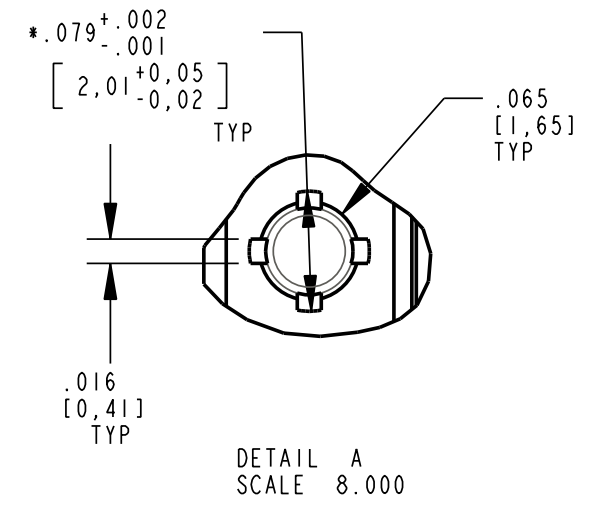
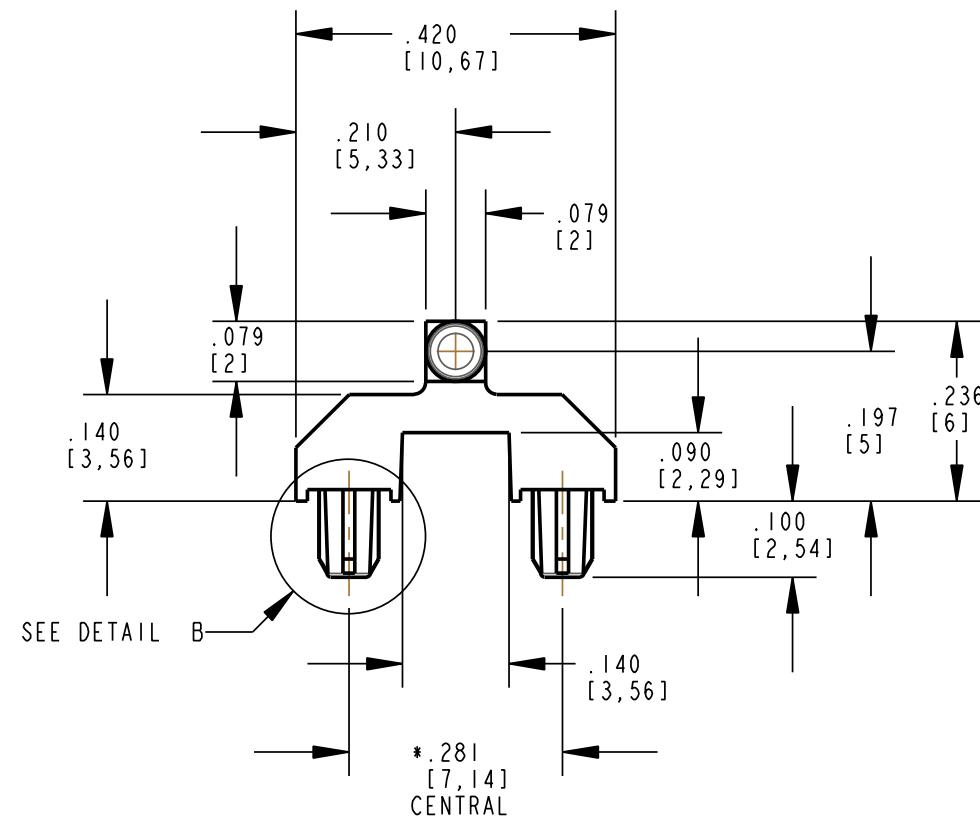
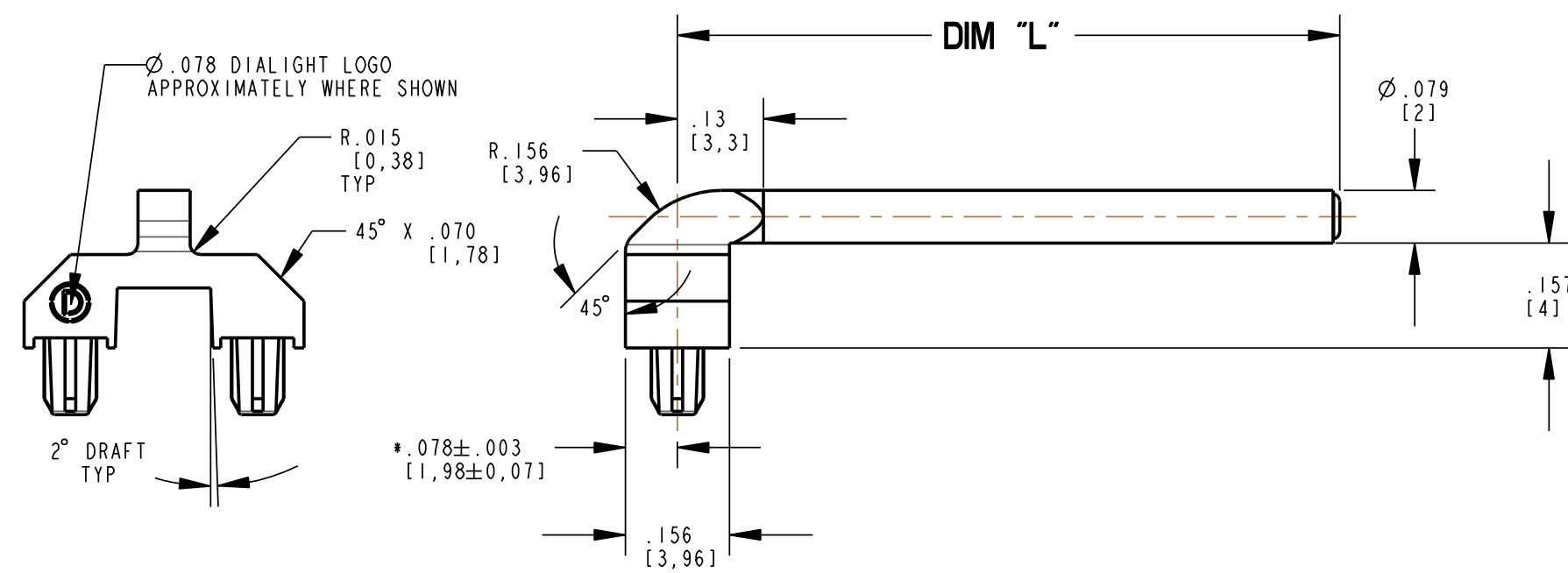

RoHS Compliant 515-1141-XXF 2mm Lightpipe
Part Numbers with the "F" suffix ending are RoHS Compliant.
Example: 515-1140-100F
Packaging is marked with "RoHS Compliant" label or equivalent markings.

THIS DRAWING AND THE CONTENTS HEREIN ARE CONFIDENTIAL AND THE SOLE PROPERTY OF DIALIGHT. REPRODUCTION OF THIS DRAWING OR CONSTRUCTION OF ANY PARTS WITHIN THIS DRAWING ARE FORBIDDEN WITHOUT THE WRITTEN CONSENT OF DIALIGHT.		
SCALE: 4.000	DRAWING NUMBER: C-17211	REV: C
ALL DIM'S IN: INCHES (MM)	PART NUMBER SEE CHART	
TOLERANCES: UNLESS OTHERWISE SPECIFIED	TITLE LIGHTPIPE, 2MM DIA, 5MM CL RoHS COMPLIANT	
FRACTIONS: ±1/64	MATERIAL: SEE NOTES	
DECIMALS (.XX): ±.01	FINISH: N/A	
DECIMALS (.XXX): ±.005	Dialight	
DECIMALS (.XXXX): ±.0005	1501 ROUTE 34 SOUTH FARMINGDALE, NJ 07727	
ANGLES: ±1°	FSCM: 83330	SHEET 1 OF 2 FAMILY TABLE:

