

LOC		DIST		REVISIONS			
AA	00	REV	DATE	BY	CHK	APPV	
C1	REVISED PER ECO-11-005140	28MAR11	RK	HMR			

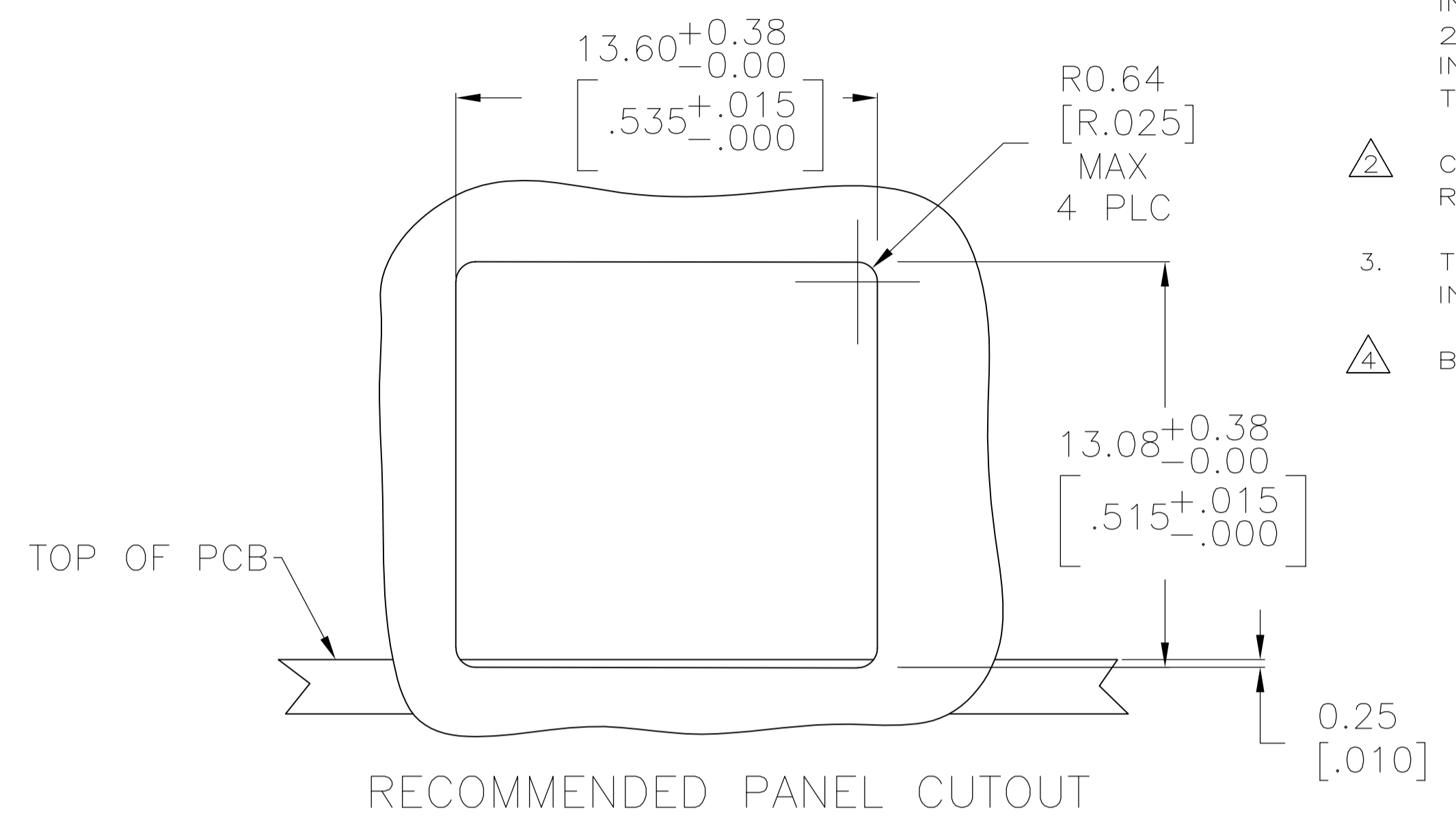

- MATERIAL: HOUSING - PBT POLYESTER, BLACK.
TERMINAL - 0.35 [.0138] THICK PHOSPHOR BRONZE PLATED WITH 1.27µm [.000050] THICK HARD GOLD IN LOCALIZED GOLD PLATE AREA AND 2.03µm [.000080] THICK MATTE TIN IN SOLDER AREA OVER 1.27µm [.000050] THICK NICKEL UNDERPLATE.
- CAVITY CONFORMS TO FCC RULES AND REGULATIONS PART 68, SUBPART F.
- TERMINALS FOR 5555163-2 AND -5 LOCATED IN CENTER POSITIONS.
- BULK PACKAGED IN A TRAY.

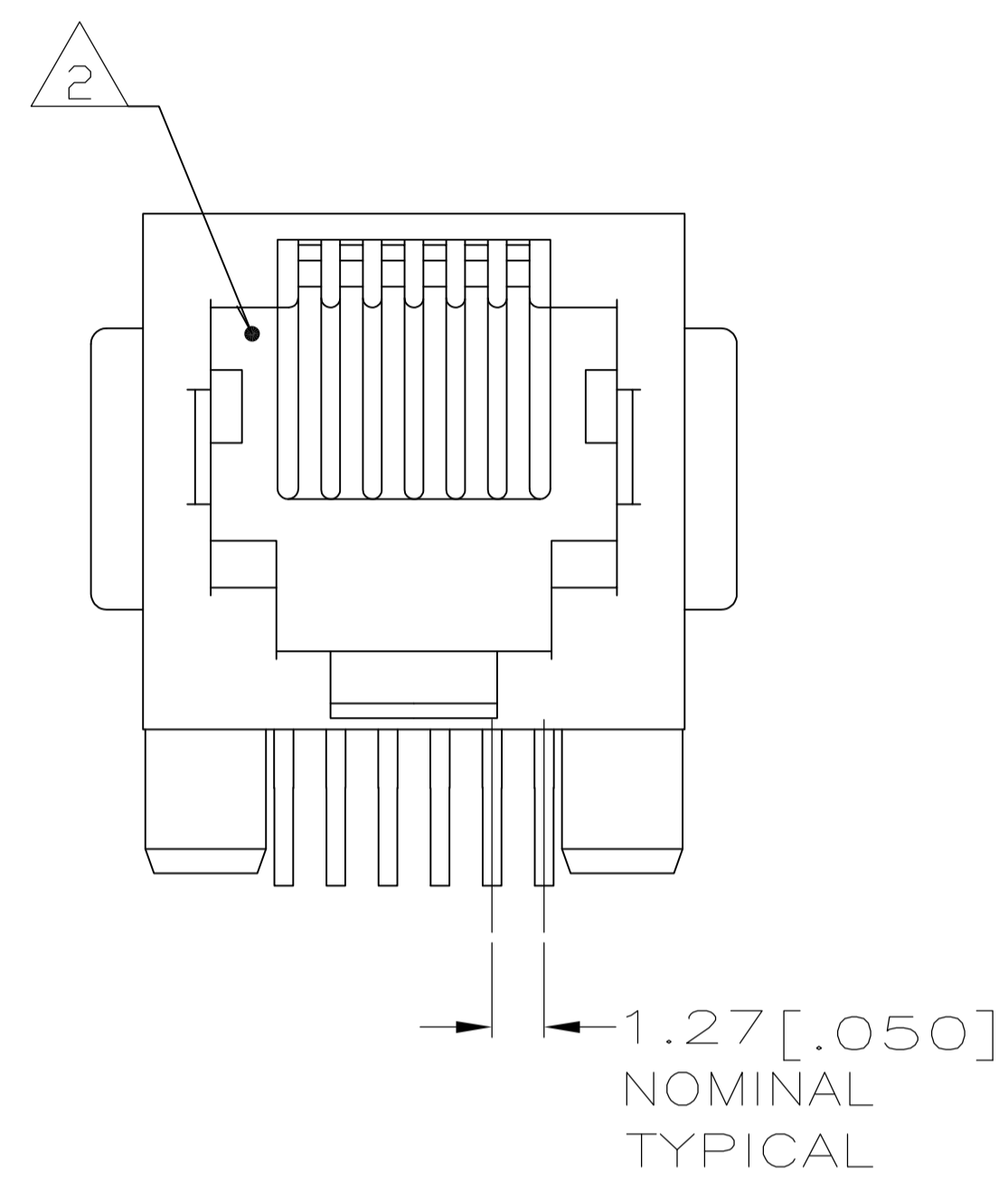
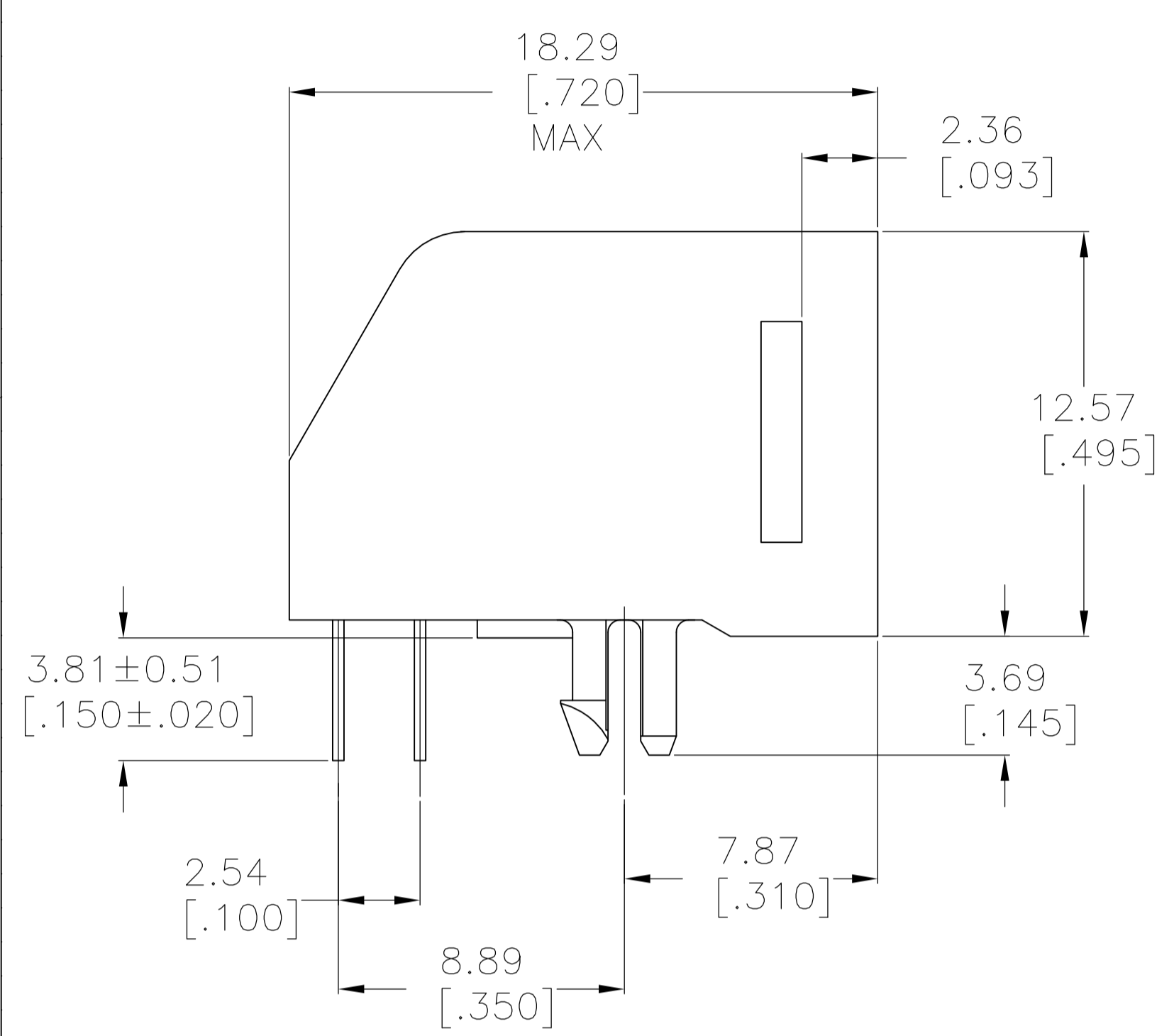
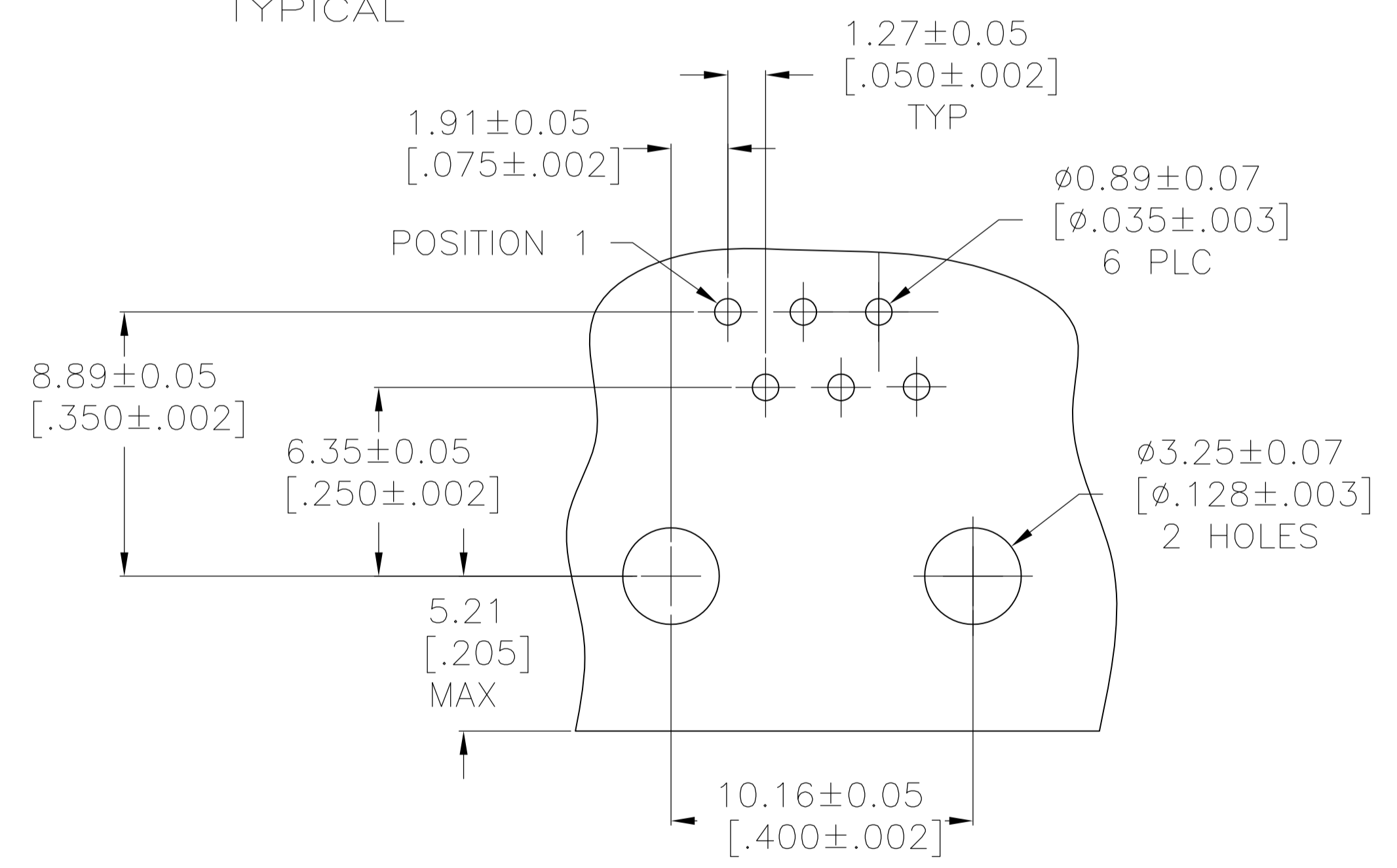
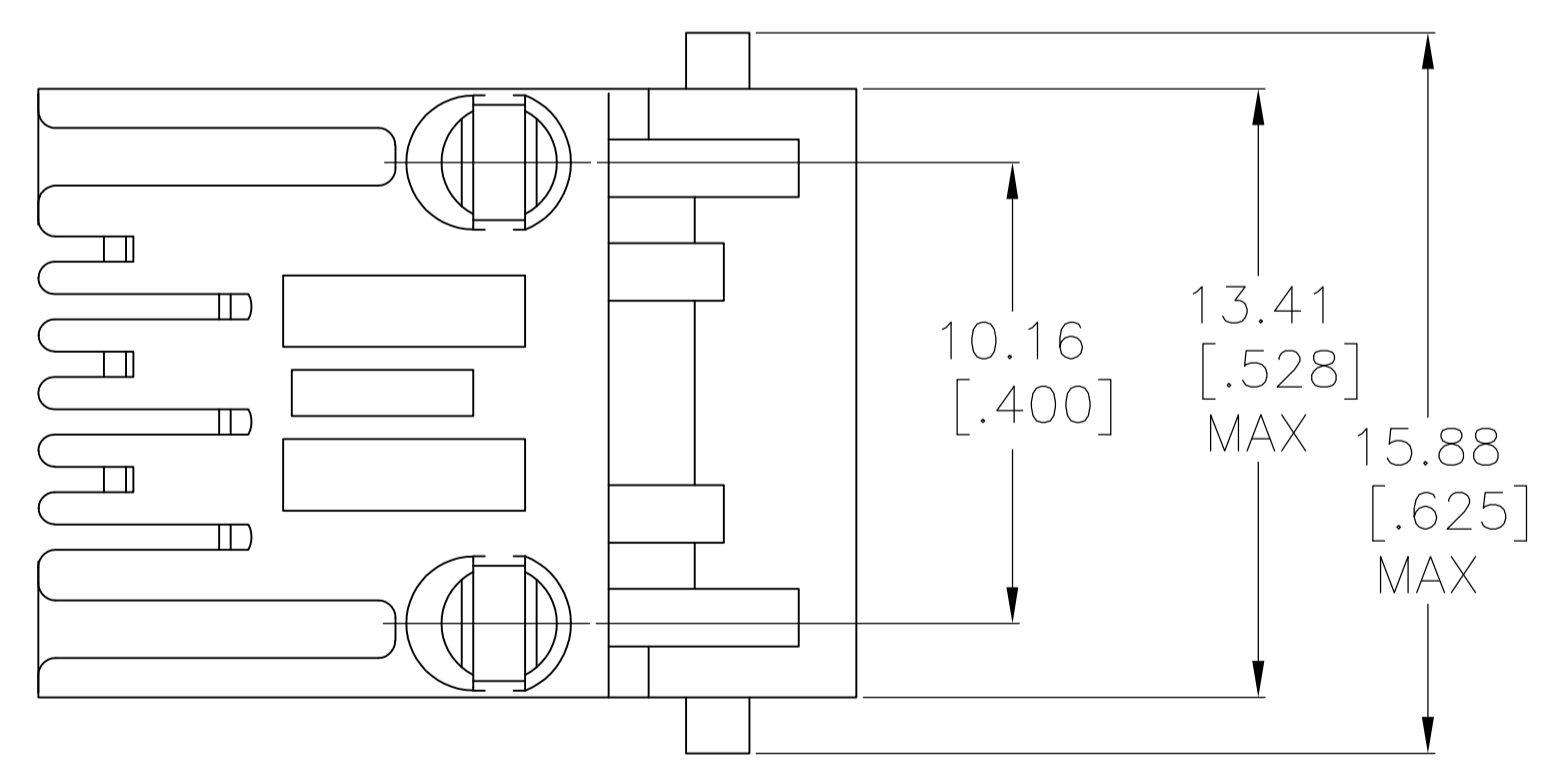

RECOMMENDED PRINTED CIRCUIT BOARD LAYOUT COMPONENT SIDE SHOWN

REV	DATE	DESCRIPTION	BY	CHK	APPV
2		5555163-5			
4		5555163-2			
6		5555163-1			

THIS DRAWING IS A CONTROLLED DOCUMENT.		DIN G. ATTADIA - 08/JUN/2005		TE Connectivity	
DIMENSIONS: mm [INCHES]		TOLERANCES UNLESS OTHERWISE SPECIFIED:		APVD S. FLICKINGER 08/JUN/2005	
0 PLC ± -		1 PLC ± -		NAME: MODULAR JACK ASSEMBLY, 6 POSITION, LOW PROFILE, RIGHT ANGLE, WITH PANEL STOPS	
2 PLC ± 0.13[.005]		3 PLC ± -		PRODUCT SPEC: 108-1163	
4 PLC ± -		ANGLES ± -		APPLICATION SPEC: 114-2048	
MATERIAL: SEE NOTE 1		FINISH: SEE NOTE 1		SIZE: A1	
		WEIGHT: -		SCALE: 6:1	
		CUSTOMER DRAWING		SHEET 1 OF 1	