



### FEATURES:

- Unregulated
- 4 Pin SIP Package
- Low ripple and noise
- High efficiency up to 82%
- Operating temperature -40°C to +105°C
- Input / Output isolation 1500 VDC
- Pin compatible with multiple manufacturers
- Continuous Short Circuit Protection



### Models Single output

Model	Input Voltage (VDC)	Output Voltage (VDC)	Output Current max (mA)	Isolation (VDC)	Max. Capacitive Load (μF)	Efficiency (%)
AM1SS-0303S-NZ ‡*	2.97-3.63	3.3	303	1500	220	72
AM1SS-0305S-NZ ‡	2.97-3.63	5	200	1500	220	76
AM1SS-0312S-NZ ‡	2.97-3.63	12	84	1500	220	80
AM1SS-0503S-NZ*	4.5-5.5	3.3	303	1500	220	72
AM1SS-0503S-JZ*	4.5-5.5	3.3	303	1500	2400	74
AM1SS-0505S-NZ	4.5-5.5	5	200	1500	220	80
AM1SS-0505S-JZ*	4.5-5.5	5	200	1500	2400	82
AM1SS-0509S-NZ	4.5-5.5	9	111	1500	220	80
AM1SS-0509S-JZ*	4.5-5.5	9	111	1500	1000	83
AM1SS-0512S-NZ	4.5-5.5	12	84	1500	220	81
AM1SS-0512S-JZ*	4.5-5.5	12	84	1500	560	83
AM1SS-0515S-NZ	4.5-5.5	15	67	1500	220	81
AM1SS-0515S-JZ*	4.5-5.5	15	67	1500	560	83
AM1SS-0524S-NZ ‡	4.5-5.5	24	42	1500	220	81
AM1SS-0524S-JZ*	4.5-5.5	24	42	1500	220	85
AM1SS-1203S-NZ*	10.8-13.2	3.3	303	1500	220	72
AM1SS-1205S-NZ	10.8-13.2	5	200	1500	220	80
AM1SS-1209S-NZ	10.8-13.2	9	110	1500	220	80
AM1SS-1212S-NZ	10.8-13.2	12	83	1500	220	81
AM1SS-1215S-NZ	10.8-13.2	15	67	1500	220	80
AM1SS-1224S-NZ	10.8-13.2	24	42	1500	220	80
AM1SS-1515S-NZ*	13.5-16.5	15	67	1500	220	81
AM1SS-2403S-NZ ‡*	21.6-26.4	3.3	303	1500	220	72
AM1SS-2405S-NZ ‡	21.6-26.4	5	200	1500	220	80
AM1SS-2409S-NZ ‡	21.6-26.4	9	110	1500	220	80
AM1SS-2412S-NZ ‡	21.6-26.4	12	83	1500	220	81
AM1SS-2415S-NZ ‡	21.6-26.4	15	67	1500	220	82
AM1SS-2424S-NZ ‡	21.6-26.4	24	42	1500	220	82

‡ With Momentary short circuit protection of 1 second

### Input Specifications

Parameters	Conditions	Typical	Maximum	Units
Voltage range	Nominal 3.3V input	2.97-3.63		VDC
	Nominal 5 input	4.5-5.5		
	Nominal 12 input	10.8-13.2		
	Nominal 15 input	13.5-16.5		
	Nominal 24 input	21.6-26.4		
Absolute Max Rating (1 sec. max.)	Nominal 3.3 input		5	VDC
	Nominal 5 input		9	
	Nominal 12 input		18	
	Nominal 15 input		21	
	Nominal 24 input		30	

Input no load current	3.3V output models with suffix NZ	30	70	mA
	5V output models with suffix NZ	20	60	
	12V output models with suffix NZ	15	50	
	15V output models with suffix NZ	10	35	
	24V output models with suffix NZ	17	30	
	3.3V/5V output models with suffix JZ	5	10	
	9V/12V output models with suffix JZ	12	20	
	15V/24V output models with suffix JZ	18	30	
Reflected Ripple Current		15		mA
Filter	Capacitor			
Hot Plug	Unavailable			

Note: Reflected ripple current testing method please see DC-DC Converter Application Notes for specific operation.

## Isolation Specifications

Parameters	Conditions	Typical	Rated	Units
Tested I/O voltage	60 sec		1500	VDC
Resistance		> 1000		MOhm
Capacitance		20		pF

## Output Specifications

Parameters	Conditions	Typical	Maximum	Units
Voltage accuracy	See tolerance graph	±5		%
Short Circuit protection		Continuous, unless marked with ‡		
Line voltage regulation	For 1.0% Vin, 3.3V Model For 1.0% Vin, Other Model		±1.5 ±1.2	% of Vin
Load voltage regulation	10 – 100% load for parts with suffix NZ	3.3V output	18	
		5V output	12	
9V output		8		
12V output		7		
15V output		6		
		24V output	5	
	10 – 100% load for parts with suffix JZ	3.3V output	15	%
		5V output	10	
		9V output	8	
		12V output	7	
		15V output	6	
		24V output	5	
Temperature coefficient		±0.03		%/°C
Temperature coefficient (for part number with suffix JZ)		±0.02		%/°C
Ripple & Noise	At 20 MHz Bandwidth	60	150	mV p-p
Ripple & Noise (for part number with suffix JZ)	At 20 MHz Bandwidth	Other Model	30	75
		24V Model	50	100

## General Specifications

Parameters	Conditions	Typical	Maximum	Units
Switching frequency	100% load	100-300		KHz
Switching frequency (for part number with suffix JZ)	100% load	270		KHz
Operating temperature	Derating Above 85°C	-40 to +105		°C
Storage temperature		-55 to +125		°C
Maximum case temperature			125	°C
Cooling	Free air convection			
Humidity	Non condensing		95	%
Soldering Lead Temperature	1.5mm from Lead, for 10 Sec		300	°C
Case material	Plastic UL94-V0			
Weight		1.3		g

Dimensions (L x H x W)	0.46 x 0.4 x 0.24 inches	11.60 x 10.16 x 6.00 mm
MTBF	>3500K hrs(MIL-HDBK -217F, Ground Benign, t=+25°C)	

NOTE: All specifications in this datasheet are measured at an ambient temperature of 25°C, humidity<75%, nominal input voltage and at rated output load unless otherwise specified.

### Safety Specifications

Parameters		
Agency approvals	cULus	
Standards	Information technology Equipment	UL 60950-1 (except the models marked with *)
		Design to meet UL 62368 (for part number with suffix JZ)

### Pin Out Specifications

Pin	Single
1	- V Input
2	+V Input
3	-V Output
4	+V Output

### Dimensions for part number with suffix JZ

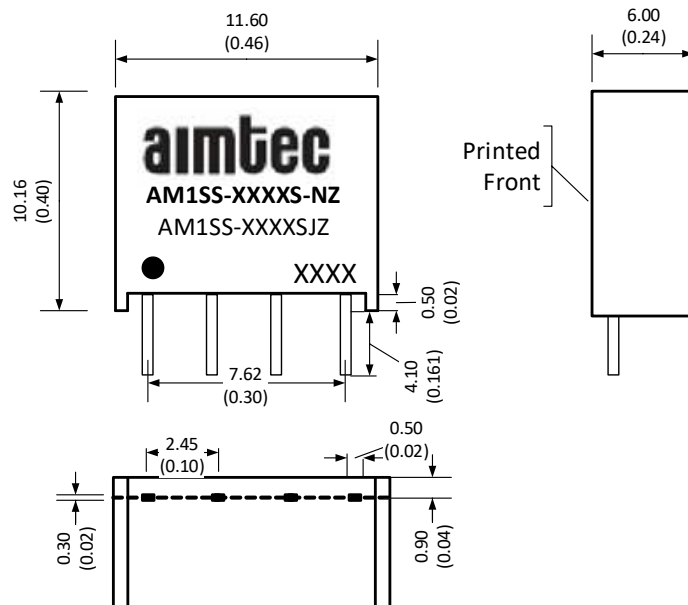

### Typical Application Circuit

#### Capacitor selection Table

V <sub>in</sub>	C1	Single VDC	C2
3.3	4.7 μF	3.3 V	10 μF
5	4.7 μF	5 V	10 μF
12	2.2 μF	9 V	4.7 μF
15	2.2 μF	12 V	2.2 μF
24	1 μF	15 V	1 μF
		24V	0.47 μF
for part number with suffix JZ		9 V	2.2 μF
		24 V	1 μF

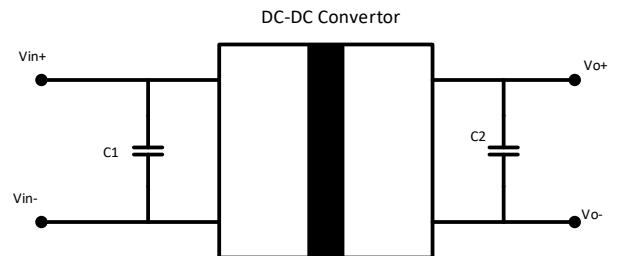

**Derating**

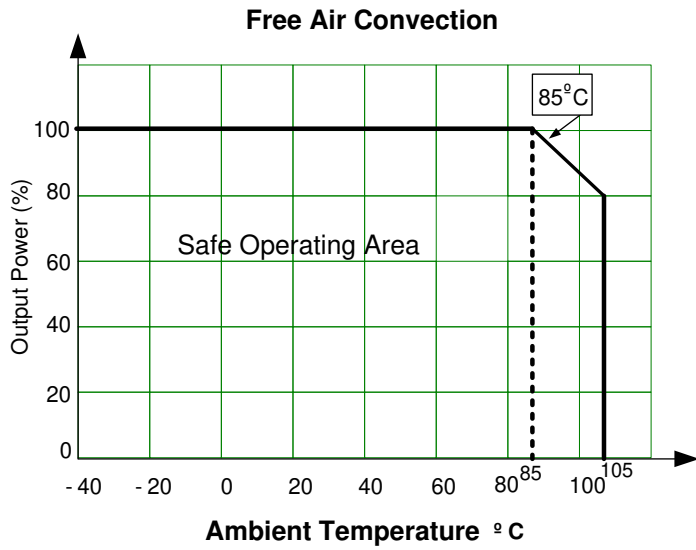

**Typical Characteristics**

**AM1SS-0503SJZ**

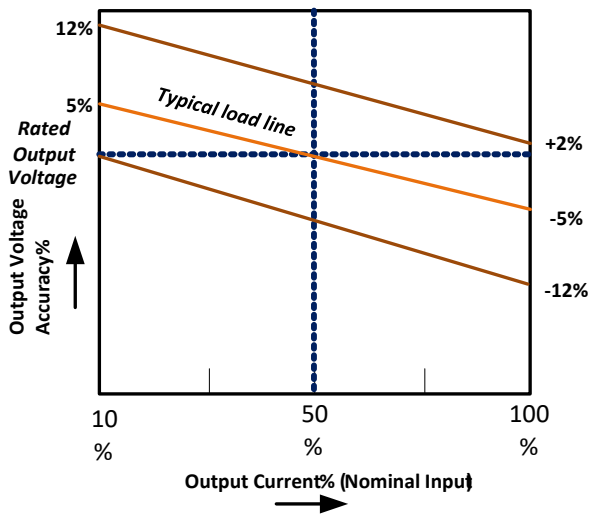

**Other Model**

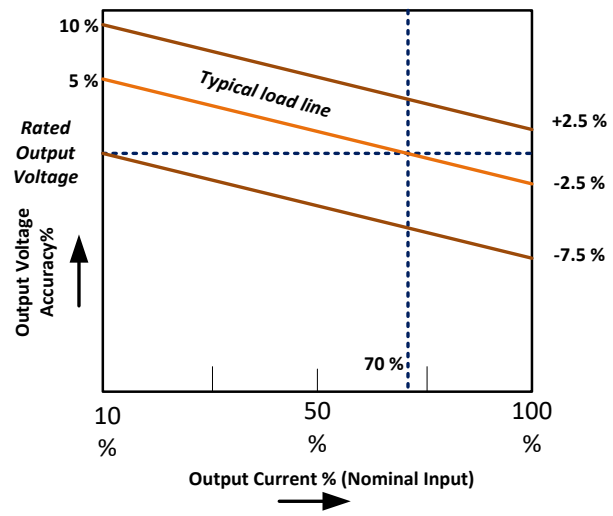

**Recommended Circuit for EMI Class B**

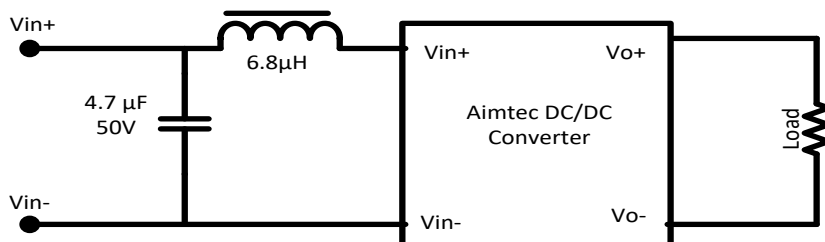

**Recommended Circuit for EMI Class B (for part numbers with suffix JZ)**

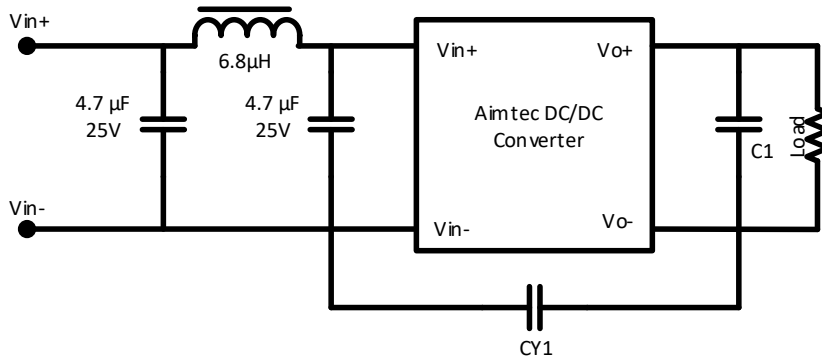

Single VDC	C1	CY1
3.3 V	10 µF	N/C
5 V		
9 V	2.2µF	1nF / 4KVDC VISHAY HGZ102MBP TDK CD45-E2GA102M-GKA
12 V		
15 V	1µF	
24V		

**NOTE:** 1. Datasheets are updated as needed and as such, specifications are subject to change without notice. Once printed or downloaded, datasheets are no longer controlled by Aimtec; refer to [www.aimtec.com](http://www.aimtec.com) for the most current product specifications. 2. Product labels shown, including safety agency certifications on labels, may vary based on the date manufactured. 3. Mechanical drawings and specifications are for reference only. 4. All specifications are measured at an ambient temperature of 25°C, humidity<75%, nominal input voltage and at rated output load unless otherwise specified. 5. Aimtec may not have conducted destructive testing or chemical analysis on all internal components and chemicals at the time of publishing this document. CAS numbers and other limited information are considered proprietary and may not be available for release. 6. This product is not designed for use in critical life support systems, equipment used in hazardous environments, nuclear control systems or other such applications which necessitate specific safety and regulatory standards other than the ones listed in this datasheet. 7. Warranty is in accordance with Aimtec's standard Terms of Sale available at [www.aimtec.com](http://www.aimtec.com).