

SW2011

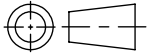

Revision level		Revision Record	Changed	Date	Approved	Date
Drawing	Part					
03		SEE ECN# 012340	WPT	09/12/2011	CJR	04/11/2013

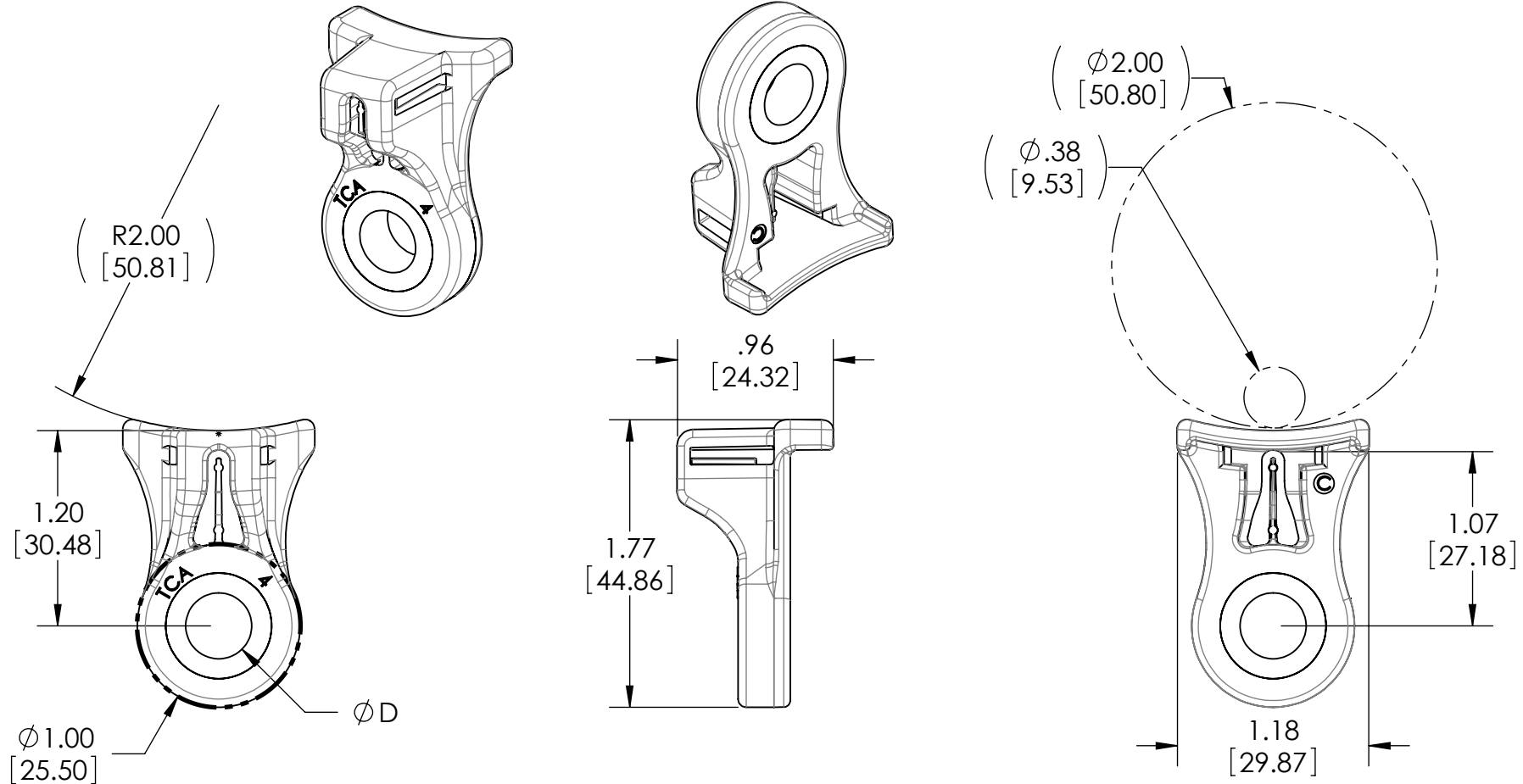

Material
PA66HIRHSUV

- FEATURES:
 1. METAL BUSHING WITHSTANDS 114 lb-ft (155 N-m) OF TORQUE APPLIED TO FASTENER
 2. 200 lb LOAD ASSEMBLY STRENGTH PERPENDICULAR TO BOLT AXIS

PART NUMBER	PART REV	Ø D	BOLT SIZE
SAM320B	C	0.327 [8.31MM]	5/16" & 8MM
SAM400B	C	0.405 [10.29MM]	3/8" & 10MM
SAM500B	C	0.51 [12.95MM]	1/2" & 12MM

Units inches

Dimension without tolerances details to:

- .xxxx = ± .005
- .xxx = ± .01
- .xx = ± .02
- .x = ± .1
- None = ± .06
- ∠ = ± 0.5°

The copyright of this drawing is reserved by HellermannTyton. It is issued on condition that it is not reproduced, copied, or disclosed to a third party, either wholly or in part, without the consent of HellermannTyton.

Drawn	WPT	05/16/2011
Approved	WPT	07/08/2012
HellermannTyton		
North America Email: corp@htamericas.com Web: www.hellermann.tyton.com		

Article/Type-No	SEE TABLE	Scale	1:1
Title	Axial Mount with Metal Bushing	Project Number	PRP10-0840
Drawing-No	10-0840-008-CSU	Production : Phase	Format AH
			Sheet 1/1