

LOADING PATTERN MATING SIDE

y	6	6	6	6	6	6	6	6	6	6
h	4	4	4	4	4	4	4	4	4	4
g	4	4	4	4	4	4	4	4	4	4
f	4	4	4	4	4	4	4	4	4	4
e	4	4	4	4	4	4	4	4	4	4
d	4	4	4	4	4	4	4	4	4	4
c	4	4	4	4	4	4	4	4	4	4
b	4	4	4	4	4	4	4	4	4	4
a	4	4	4	4	4	4	4	4	4	4
z	6	6	6	6	6	6	6	6	6	6
POS	01		05						10	

LOADED CONNECTOR ASSEMBLY (FOR EXAMPLE)

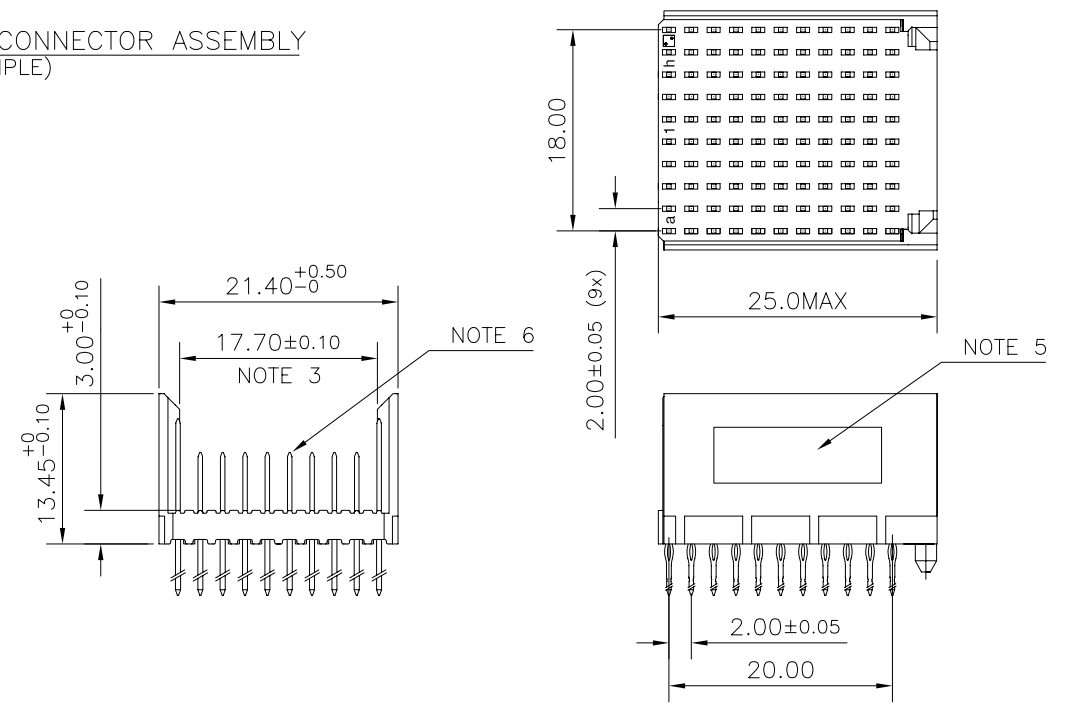

CONTACT OVERVIEW

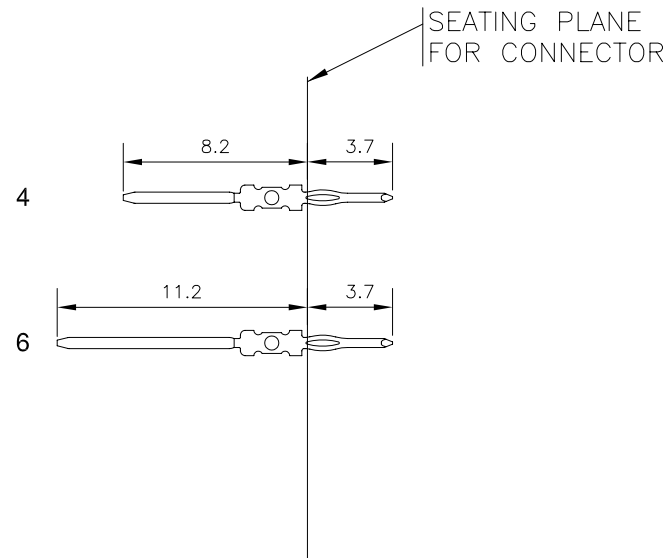

LEAD FREE INDICATOR : LF = LEAD FREE (DIGIT 15 & 16)
 PLATING CODE (DIGIT 13 AND 14)

HM2P89PA8111----

PLATING TABLE

CODE	PLATING	CONTACT AREA	TYPE OF TERMINAL	PERFORMANCE LEVEL
AA	0.75μ Au	GOLD OVER NICKEL PLATING.	SHORT TERMINAL EON PRESSFIT CONTACTS	IEC PERFORMANCE LEVEL 2 (250 mating cycles) or TELCORDIA CO
AB	1.25μ Au	GOLD OVER NICKEL PLATING.	SHORT TERMINAL EON PRESSFIT CONTACTS	TELCORDIA UE

LAY-OUT P.C.B.-HOLE

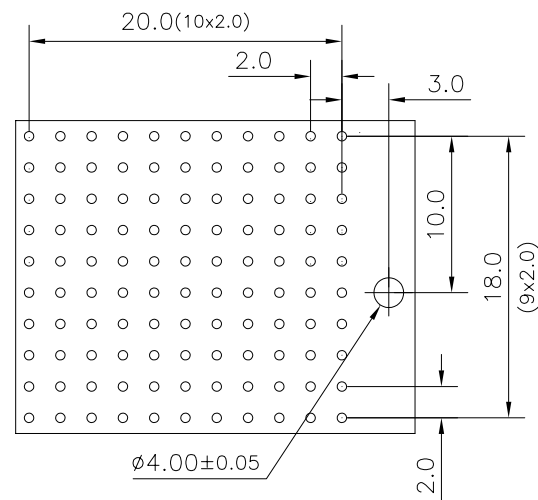

NOTES

- THIS PRODUCT IS CSA APPROVED.
- THIS PRODUCT IS UL RECOGNIZED.
- MEASURED AT THE BOTTOM.
- MATERIAL CONTACT: PHOSPHOR BRONZE
HOUSING : CREAM WHITE GLASS FILLED POLYESTER UL-94V0
- CONNECTOR PRINTED WITH P/N AND DATE CODE.
- FOR ACTUAL CONTACT LOADINGS, SEE LOADING PATTERN MATING SIDE.
- SHAPE OF CONNECTOR HOUSING CAN ALTER DEPENDING ON PRODUCTION LOCATION
- THE PRODUCT (LF) MEETS EUROPEAN UNION DIRECTIVES AND OTHER COUNTRY REGULATIONS AS DESCRIBED IN GS-22-008
- FOR RECOMMENDED PTH DIMENSIONS REFER DRAWING : BS, A , 201572 , 001

CATALOG NO: HM2P89PA8111----

mat'l. code		surface		tolerance		projection		product family	
SEE NOTE 4		ISO 1302 ✓		ISO 406 ISO 1101				MILLIPACS	
ltr		ecn no		dr		date		title	
A		109-0210		MINI		2009-10-06		MPACS 8+2R STR HDR PF CONN TYPE F	
B		109-0290		AB		2009-12-29			
C		110-0018		MINI		2010-01-13			
				dr		MINI K VANDANATH 2009-10-06		dwg no	
				enr		ALEX BABU 2009-10-06		sheet 1 of 1	
				chr		ALEX BABU 2009-10-06		size	
				appd		ALEX BABU 2009-10-06		A3	
sheet index		revision sheet		c				type Product Customer Drawing	
		1							