

JOHNSON®



RF & Microwave Connectors & Cable Assemblies

Product Catalog



cinch
CONNECTIVITY SOLUTIONS
a bel group

cinch.com

Cinch Connectivity Solutions has a wide range of cable assemblies and connectors suited for RF, Microwave and Fiber Optic signal transmission. Connectivity Solutions is a vertically integrated supplier of custom, fixed length and semi-rigid cable assemblies from DC to 50 GHz. Our product lines deliver custom-engineered products and solutions to satisfy the most demanding and complex requirements.

AIM CAMBRIDGE



AIM-Cambridge has a universal line of products that offer cost effective, high quality solutions for connectivity. Our connectors are available in BNC, Type N, F Type, RCA, UHF, Mini-UHF, TNC, D-Sub and Modular Plugs for Data/Telecom applications. In addition, we stock a wide variety of cables for A/V, SATV, CATV, computer and LAN applications, as well as a complete line of termination tools and structured cabling products. AIM-Cambridge promises that its product will provide you with unmatched consistency, quality, reliability and ease of use.

JOHNSON®



Johnson designs and manufactures an industry leading line of RF coaxial connectors and adapters, which are available in both 50 and 75 ohm versions. Johnson connectors are designed to provide the highest quality data transmission for audio, video and data applications. The Johnson line of products can address frequency ranges from DC to 46GHz and all sizes from Ultra-miniature interfaces (UMC), Micro-miniature, (MCX, MMCX, SMP), Subminiature (SMA, SMB, SMK, kwiQMate™), Medium connectors (Type N connectors) through to large connectors (DIN7/16). The breadth of products available within the Johnson range includes board and cable mount connectors as well as semi-rigid, conformable, and flexible RF coaxial cables.

MIDWEST MICROWAVE



Midwest Microwave manufactures passive coaxial microwave components that are known for their precision performance and high quality that meets the precise requirements of the RF/Microwave industry. Our broad product portfolio includes: Attenuators, Precision Adapters, Terminations, DC Blocks, Power Dividers, Couplers, Equalizers, Phase Shifters, Connectors, Custom Cable Assemblies and Test Cables that are designed and manufactured for both military and commercial applications.

Midwest also offers a wide variety of Qualified Product List (QPL) approved products in the M3933, M39030 and M39012 series, as well as many DESC/DSCC approved models.

**Semflex
microwave solutions**



Semflex designs and manufactures low loss, flexible, microwave coaxial cable and custom cable assemblies for the military/aerospace, commercial OEM and test instrumentation markets. Semflex offers cables ranging from DC to 50 GHz, available with ultra low insertion loss, power ratings up to 21 KW, and available with all popular connectors.

**STRATOS
optical technologies**



Stratos optical connectivity products is globally recognized as highly reliable, cost-effective, and provides optical connectivity solutions that are virtually immune to dust, mud, oil, water, and other contaminants.

Our expanded beam connectivity products are ideal for harsh environment applications in the broadcast, industrial, petrochemical and military/aerospace markets where high reliability, low maintenance and quick serviceability are critical requirements. Our optical active products are used mainly in military, aerospace and industrial markets where high speed/high reliable performance is mission critical. The active product line includes optical transceivers, optical media converters and custom devices tailored to your application.

**TROMPETER
RF connectivity**



Trompeter is recognized as a global leader in delivering best in class RF connectivity products. The Trompeter line of patch jacks, RF connectors, cable assemblies, HDTV digital technology and DS3 connectivity solutions is unrivalled. Our mission is to provide products that continually deliver the highest quality signal integrity for the most demanding applications in Telecom, Central Office, Broadcast, Military Aerospace, and Instrumentation markets worldwide. Our extensive line of cost-effective products are rigorously designed and tested to provide the critically engineered solutions necessary to enhance the end-user's overall experience.

**VITELEC®
ELECTRONICS**



Vitelec provides a comprehensive range of RF coaxial interconnect products and cable assemblies. The company has a long established reputation for offering quality and innovation with a wide range of both standard and custom designed products for the electronic and communication industries.

MMCX Connectors

50 Ohm Connectors	
Specifications.....	4
Semi-Rigid and Flexible Cable.....	6
PC Mount.....	8
Termination	9
Non-Magnetic Connectors - 50 Ohm	
Specifications.....	11
Semi-Rigid and Flexible Cable.....	12
PC Mount.....	12
Other Information	
Assembly Tools	185
Cable Information	192
Assembly Instructions	193
Mounting Hole Layouts	194
Index	274
Competitor Cross Reference	280

3	MMCX Connectors
13	MCX Connectors
39	SMK Connectors
45	SMA Connectors
103	SMB Connectors
131	SMC Connectors
137	SMP Connectors
145	Type N Connectors
153	Shielded Cable Terminations
157	Between-Series Adapters
161	Fixed Length Cable Assemblies
173	Ultra Miniature Connectors (UMC)
181	kwiQMAte™ Connectors
185	Tools
193	Assembly Instructions
257	Electronic Hardware
274	Index

While every precaution has been taken to ensure accuracy and completeness herein, Cinch Connectivity Solutions assumes no responsibility, and disclaims all liability for damages resulting from use of this information or for any errors or omissions. Specifications subject to change without notice.

Specifications

Electrical Specifications

Impedance: 50 Ohms

Frequency Range:

Connectors.....	0-6 GHz
Dummy loads.....	0-1 GHz

VSWR (max): (f = GHz)

	Straight Cable Connectors	Right Angle Cable Connectors
.047 OD	1.20	1.14 + .07f
RG-178, RG-316, RG-316 DS.....	1.20	1.25
RG-405.....	1.15	1.15
Uncabled receptacles, dummy loads.....	N/A	

Working Voltage:

Connectors	170 VRMS at sea level†
Dummy loads.....	N/A

Dielectric Withstanding Voltage:

Connectors.....	500 VRMS at sea level†
Dummy loads.....	N/A

Insulation Resistance: 1000 megohms min

Contact Resistance: (milliohms max)

	Initial	After Environmental
Center contact (straight cabled connectors and uncabled receptacles).....	5.0	8.0
Center contact (right angle cabled connectors).....	5.0	15.0
Outer contact (all connectors).....	1.0	1.5
Braid to body	1.5	N/A

Corona Level:

Connectors	190 volts min at 70,000 feet†
Dummy loads.....	N/A

Insertion Loss: (dB max, tested at 1 GHz)

Straight cabled connectors	0.1
Right angle cabled connectors	0.2
Uncabled receptacles, dummy loads.....	N/A

RF Leakage: (dB min, tested at 2.5 GHz)

Flexible cable	-60 dB
RG-405	-70 dB
Dummy loads	N/A

RF High Potential Withstanding Voltage: (400 VRMS at 4 and 7 MHz)†

Power Rating (Dummy Load): 0.5 watt @ +25°C, derated to 0.25 watt @ +125° C

†Avoid user injury due to misapplication. See safety advisory definitions inside front cover.

Mechanical Specifications

Engagement Design: Series MMCX

Engagement/Disengagement Force: 8 lbs max axial engagement
1.4 lbs min axial disengagement

Contact Retention: 2.0 lbs min axial force

Cable Retention:

	Axial Force* (lbs)	Torque (oz-in)
.047 flexible	3.5	N/A
RG-178.....	7.0	N/A
RG-316.....	20.0	N/A
RG-316 DS.....	25.0	N/A
RG-405.....	30.0	16

*Or cable breaking strength whichever is less.

Durability: 500 cycles min

Environmental Specifications

(Meets or Exceeds the Applicable Paragraph of MIL-PRF-39012)

Temperature Range:

Connectors - 65°C to + 165°C
 Dummy loads - 65°C to + 125°C

Thermal Shock: MIL-STD-202, Method 107, Condition C, except -55°C to +155°C (N/A dummy loads)

Corrosion: MIL-STD-202, Method 101, Condition B (N/A dummy loads)

Shock: MIL-STD-202, Method 213, Condition B (N/A dummy loads)

Vibration: MIL-STD-202, Method 204, Condition D (N/A dummy loads)

Moisture Resistance: MIL-STD-202, Method 106 (N/A dummy loads)

Material Specifications

Bodies: Brass per ASTM B16, gold plated** per MIL-DTL-45204 .00001" min
Contacts: Beryllium copper per ASTM B196, gold plated per MIL-DTL-45204 .00003" min
Interface Spring: Beryllium copper per ASTM B196, gold plated per MIL-DTL-45204 .00003" min
Insulators: PTFE fluorocarbon per ASTM D 1710 and ASTM D 1457
Crimp Sleeves: Copper per ASTM B301 or brass per ASTM B16, gold plated per MIL-DTL-45204 .00001" min
Mounting Hardware: Brass (nuts) per ASTM B16 or phosphor bronze (lockwashers) per ASTM B139, gold plated per MIL-DTL-45204 .00001" min

**All gold plated parts include a .00005" min nickel barrier layer.

Mating Engagement for MMCX Series

1. ID of contact to meet VSWR mating characteristics and connector durability when mated with a dia .016 +/- .001 male contact.
2. Must meet the force to engage and disengage when mated with mating part.

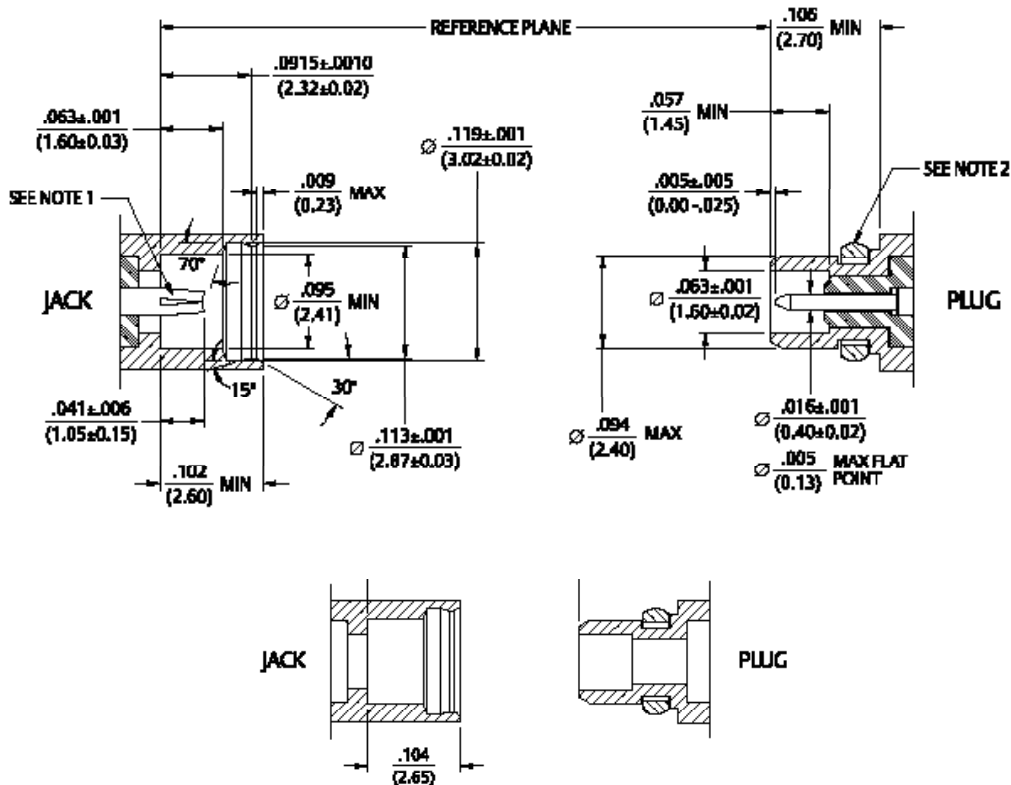

For more information, please contact customer service at (507) 833-8822 or (800) 247-8256 • cinch.com

Illustrations are shown in inches (millimeters).

Semi-Rigid and Flexible Cable

Right Angle Solder Type Plug – Captivated Contact

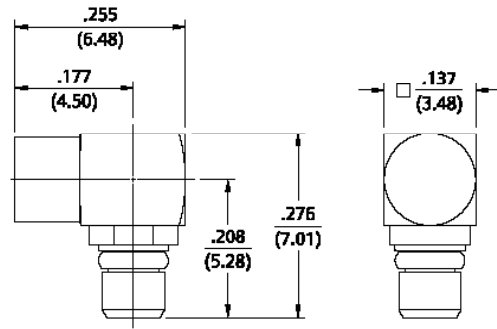

Cable Type	Gold Plated
RG-405	135-3693-101

Assembly instructions page 198.

Right Angle Crimp Type Plug – Captivated Contact

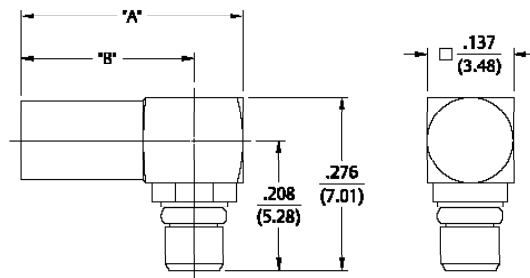

Cable Type	Gold Plated	"A"	"B"	Termination
.047" OD Flexible	135-3436-101	.354 (8.99)	.276 (7.01)	Crimp Insert
RG-178, 196	135-3402-101	.354 (8.99)	.276 (7.01)	Crimp Insert
RG-178, 196	135-3402-111	.412 (10.46)	.334 (8.48)	Crimp Sleeve
RG-316, 188, 161, 174, 179, 187	135-3403-101	.412 (10.46)	.334 (8.48)	Crimp Sleeve
RG-316 DS, 188 DS	135-3404-101	.412 (10.46)	.334 (8.48)	Crimp Sleeve

Assembly instructions page 200 and 201.

Straight Crimp Type Plug – Solder or Crimp Captivated Contact

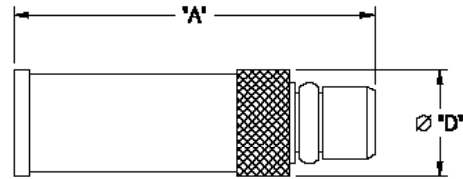

Cable Type	Gold Plated	"A"	"D"	Termination
.047" OD Flexible	135-3436-001	.462 (11.73)	.137 (3.48)	Crimp Insert
RG-178, 196	135-3402-001	.462 (11.73)	.137 (3.48)	Crimp Insert
RG-316, 188, 161, 174	135-3403-001	.509 (12.93)	.173 (4.39)	Crimp Sleeve
RG-316 DS, 188 DS	135-3404-001	.509 (12.93)	.173 (4.39)	Crimp Sleeve
RG-179, 187	135-3433-001	.509 (12.93)	.173 (4.39)	Crimp Sleeve

Assembly instructions page 202 and 203.

Straight Crimp Type Jack – Solder or Crimp Captivated Contact

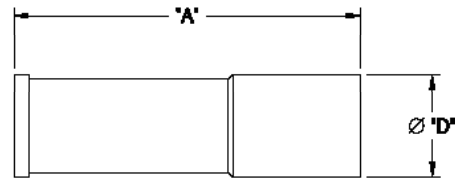

Cable Type	Part No.	"A"	"D"	Termination
.047" OD Flexible	135-3336-001	.462 (11.73)	.137 (3.48)	Crimp Insert
RG-178, 196	135-3302-001	.462 (11.73)	.137 (3.48)	Crimp Insert
RG-316, 188, 161, 174	135-3303-001	.545 (13.84)	.173 (4.39)	Crimp Sleeve
RG-316 DS, 188 DS	135-3304-001	.545 (13.84)	.173 (4.39)	Crimp Sleeve
RG-179, 187	135-3333-001	.545 (13.84))	.173 (4.39)	Crimp Sleeve

Assembly instructions page 204 and 205.

Straight Crimp Type Bulkhead Jack – Solder or Crimp Captivated Contact

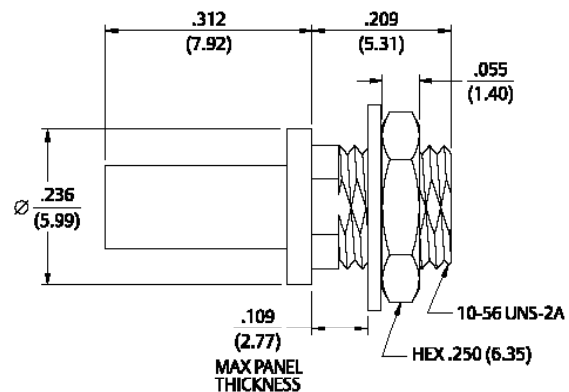

Cable Type	Gold Plated	Termination
.047" OD Flexible	135-3336-401	Crimp Insert
RG-178, 196	135-3302-401	Crimp Insert

Assembly instructions page 205.

Mounting Hole layout figure 5 page 194.

For more information, please contact customer service at (507) 833-8822 or (800) 247-8256 • cinch.com

Illustrations are shown in inches (millimeters).

PC Mount

Right Angle Jack Receptacle



Gold Plated	"A"
135-3701-301	.115 (2.92)
135-3701-311	.068 (1.73)

Mounting Hole layout figure 12 page 194.

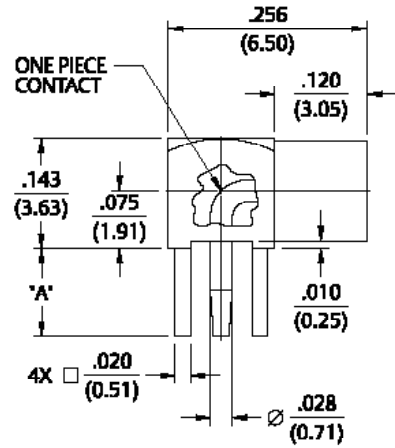

Straight Jack Receptacle



Gold Plated	"A"
135-3701-201	.115 (2.92)
135-3701-211	.068 (1.73)

Mounting Hole layout figure 12 page 194.

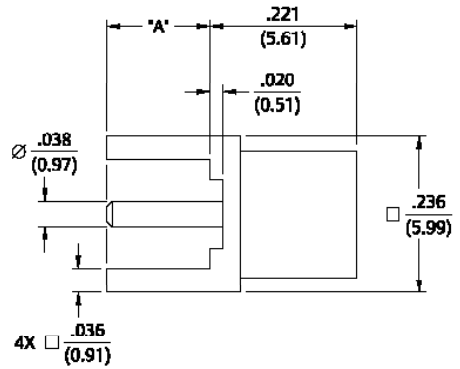

Straight Surface Mount Jack Receptacle



Gold Plated	Packaging
135-3711-201	Stock
135-3711-202	Tape and Reel, 1500 pcs/reel

Recommended Land Pattern figure 15 page 195.
Tape and Reel .315 (8.0) component pitch .630 (16.0) wide.

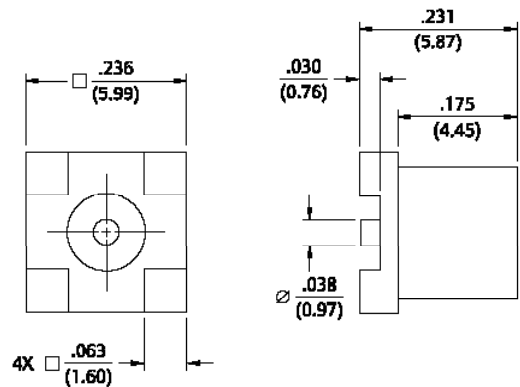

Straight Plug Receptacle

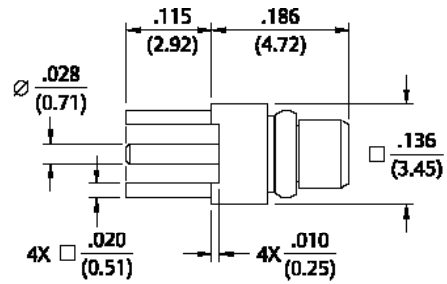

Gold Plated
135-3801-201

Mounting Hole layout figure 12 page 194.

End Launch Surface Mount Jack Receptacle

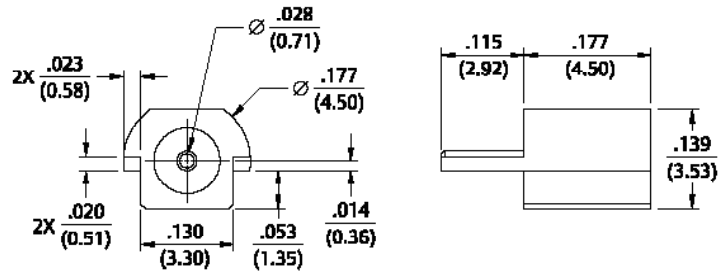

Gold Plated	Packaging
135-3711-801	Stock
135-3711-802	Tape and Reel, 1000 pcs/reel

Recommended Land Pattern and Board Notch figure 14 page 195.
Tape and Reel .316 (8.0) component pitch .630 (16.0) wide.

Plug Dummy Load

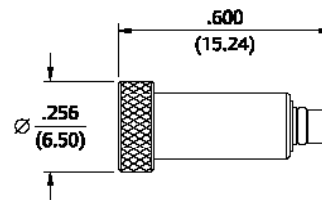

Gold Plated	Resistance
135-3801-811	50 Ohms

For more information, please contact customer service at (507) 833-8822 or (800) 247-8256 • cinch.com
Illustrations are shown in inches (millimeters).

Non-Magnetic RF Connectors

Non-Magnetic Connectors

Our line of non-magnetic connectors is one of many successful examples of how Johnson® commercializes the high-end, custom application into the cost-sensitive solution that maintains the original Mil-Spec performance. As MRI and other magnetically sensitive technologies grow and evolve so to must the Johnson connector portfolio. Stronger magnetic fields, demands for better signal-to-noise ratios, custom-sized and modular flex coils for increasingly smaller machines: the RF connectors within the equipment have to bear an increasingly tricky role of delivering higher through-put while creating less interference.

With SMA, SMB, MCX, MMCX and soon SMP interfaces made available in a variety of PC and Cable-Mount designs, we can deliver the imaging performance your customers count on.

- The materials and finishes of our connectors meet the stringent limits of image and magnetic field distortion in an MR environment.
- The connector electrical performance exceeds the frequency requirements of the Receive/Transmit RF Coils in MR equipment (typically DC-6 GHz).
- The copper alloys of the body, springs and contact parts are designed to provide uniformity and maintain low permeability and magnetic susceptibility.
- Gold finishes are altered to eliminate magnetic barrier layers and provide excellent corrosion resistance and wear characteristics.
- Plugs maintain their electrical and mechanical performances in the environments of high-vibration common with MRI machines.
- A robust connector assembly design allows for a high count of mating cycles.
- As a helpful visual cue the connectors are marked "NM".



Cinch Connectivity Solutions Non-Magnetic design capabilities expand beyond the parts and interfaces listed in this catalog. Please contact technical support to discuss the options for manufacturing your customized interconnects.

Electrical Specifications

Impedance: 50 Ohms

Frequency Range: 0-6 GHz

VSWR (max): (max) (f = GHz)

	Straight Cabled Connectors	Right Angle Cabled Connectors
.047 dia.....	1.20	1.14 + .07f
RG-178, RG-316, RG-316 DS	1.20	1.25

Working Voltage:

Connectors 170 VRMS at sea level†

Dielectric Withstanding Voltage:

Connectors 500 VRMS at sea level†

Insulation Resistance: 1000 megohms min

Contact Resistance: (milliohms max)

	Initial	After Environmental
Center contact (straight cabled connectors and uncabled receptacles)	5.0	8.0
Center contact (right angle cabled connectors)	5.0	15.0
Outer contact (all connectors)	1.0	1.5
Braid to body	1.5	N/A

Corona Level:

Connectors 190 volts min at 70,000 feet†

Insertion Loss: (dB max, tested at 1 GHz)

Straight cabled connectors.....	0.1
Right angle cabled connectors.....	0.2
Uncabled receptacles.....	N/A

RF Leakage: (dB min, tested at 2.5 GHz)

Flexible cable..... -60 dB

RF High Potential Withstanding Voltage: 400 VRMS min (tested at 4 and 7 MHz)†

Mechanical Specifications

Engagement Design: Series MMCX

Engagement/Disengagement Force: 8 lbs max axial engagement
1.4 lbs min axial disengagement

Contact Retention: 2.0 lbs min axial force

Cable Retention:

	Axial Force* (lbs)	Torque (oz-in)
.047 flexible	3.5	N/A
RG-178	7.0	N/A
RG-316	20.0	N/A
RG-316 DS	25.0	N/A
RG-405	30.0	16

*Or cable breaking strength whichever is less.

Durability: 500 cycles min

Environmental Specifications

(Meets or Exceeds the Applicable Paragraph of MIL-PRF-39012)

Temperature Range: - 65°C to + 165°C

Thermal Shock: MIL-STD-202, Method 107, Condition C (except -55° C to +155° C)

Corrosion: MIL-STD-202, Method 101, Condition B

Shock: MIL-STD-202, Method 213, Condition B

Vibration: MIL-STD-202, Method 204, Condition D

Moisture Resistance: MIL-STD-202, Method 106

Material Specifications

(See non-magnetic materials page 10)

For more information, please contact customer service at (507) 833-8822 or (800) 247-8256 • cinch.com

Illustrations are shown in inches (millimeters).

Flexible Cable and PC Mount

Right Angle Crimp Type Plug – Captivated Contact

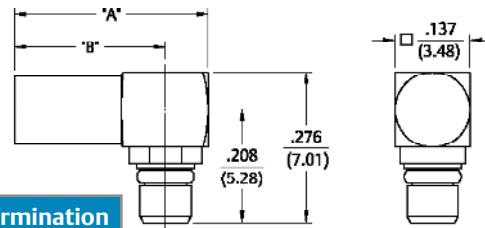

Cable Type	Gold Plated	"A"	"B"	Termination
RG-316, 188, 187, 179, 161, 174	135-9403-101	.412 (10.46)	.334 (8.48)	Crimp Sleeve
RG-178, 196	135-9402-111	.412 (10.46)	.334 (8.48)	Crimp Sleeve
.047 OD Flexible	135-9436-101	.354 (8.99)	.276 (6.98)	Crimp Insert

Assembly instructions page 199 and 200.

Straight Crimp Type Plug – Solder or Crimp Contact – Captivated Contact

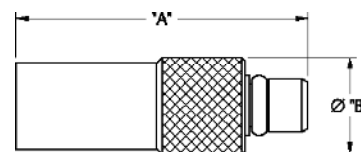

Cable Type	Gold Plated	"A"	"B"	Termination
RG-316, 188, 161, 174	135-9403-001	.509 (12.93)	.173 (4.39)	Crimp Sleeve
RG-178, 196	135-9402-001	.462 (11.73)	.137 (3.48)	Crimp Insert
.047 OD Flexible	135-9436-001	.462 (11.73)	.137 (7.01)	Crimp Insert

Assembly instructions page 204 and 205.

Straight Jack Receptacle

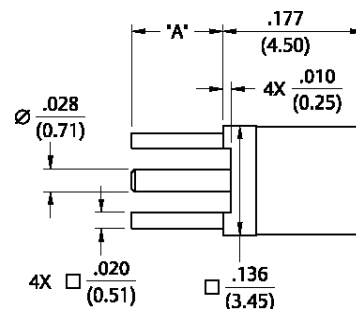

Gold Plated	"A"
135-9701-201	.115 (2.92)
135-9701-211	.068 (1.73)

Mounting hole layout figure 12 on page 195.

Right Angle Jack Receptacle

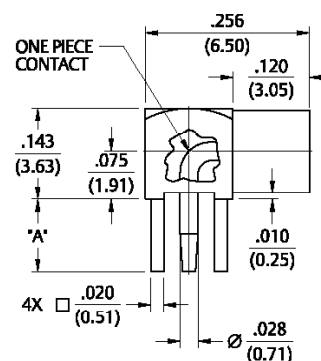

Gold Plated	"A"
135-9701-301	.155 (3.94)
135-9701-311	.068 (1.73)

Mounting hole layout figure 12 on page 195.

End Launch Surface Mount Jack Receptacle

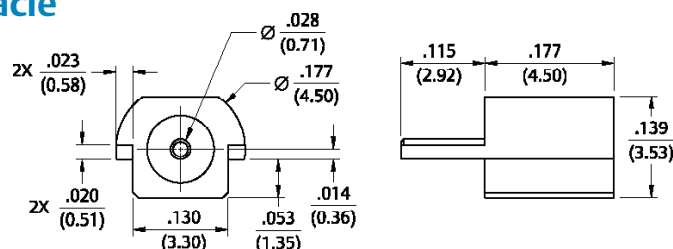

Gold Plated	Packaging
135-9711-801	Stock
135-9711-802	Tape and Reel 1000 pcs/reel

Recommended land pattern figure 14 on page 195.
Tape and Reel .316 (8.0) component pitch .630 (16.0) wide.

MCX Connectors

50 Ohm Connectors	
Specifications.....	14
Semi-Rigid & Flexible Cable	16
PC Mount.....	18
Bulkhead & Panel Mount.....	22
Adapters	23
Terminations	23
Reverse Polarity 50 Ohm Connectors	
Specifications.....	24
Semi-Rigid & Flexible Cable	26
PC Mount.....	27
75 Ohm Connectors	
Specifications.....	28
Semi-Rigid & Flexible Cable	31
PC Mount.....	32
Adapters	34
Terminations	35
50 Ohm Non-Magnetic Connectors	
Specifications.....	36
Semi-Rigid & Flexible Cable	37
PC Mount.....	38
Other Information	
Assembly Tools	185
Capabilities	190
Cable Information	192
Assembly Instruction	193
Mounting Hole Layouts	194
Numerical Index	274
Competitor Cross Reference	280

3	MMCX Connectors
13	MCX Connectors
39	SMK Connectors
45	SMA Connectors
103	SMB Connectors
131	SMC Connectors
137	SMP Connectors
145	Type N Connectors
153	Shielded Cable Terminations
157	Between-Series Adapters
161	Fixed Length Cable Assemblies
173	Ultra Miniature Connectors (UMC)
181	kwiQMate™ Connectors
185	Tools
193	Assembly Instructions
257	Electronic Hardware
274	Index

While every precaution has been taken to ensure accuracy and completeness herein, Cinch Connectivity Solutions assumes no responsibility, and disclaims all liability for damages resulting from use of this information or for any errors or omissions. Specifications subject to change without notice.

Specifications

Electrical Specifications

Impedance: 50 Ohms

Frequency Range:

Connectors 0-6 GHz

Dummy loads 0-1 GHz

VSWR: (max) (f = GHz)

	Straight Cabled Connectors	Right Angle Cabled Connectors
RG-178.....	1.17 + .04f	1.07 + .06f
RG-316 and RG-405.....	1.13 + .04f	1.07 + .04f
Adapters.....		1.13 + .04f
Uncabled receptacles, Dummy loads.....		N/A

Working Voltage: (VRMS max)†

	Sea Level	70K Feet
RG-178.....	250	65
RG-316, RG-405, uncabled receptacles, adapters.....	335	85
Dummy loads.....		N/A

Dielectric Withstanding Voltage: (VRMS min at sea level)†

RG-178 750

RG-316, RG-405, uncabled receptacles, adapters 1000

Dummy loads..... N/A

Insulation Resistance: 1,000 megohms min

Contact Resistance: (milliohms max)

	Initial	After Environmental
Center contact (straight cabled connectors and uncabled receptacles).....	5.0	8.0
Center contact (right angle cabled connectors, adapters).....	5.0	15.0
Outer contact (all connectors).....	1.0	1.5
Braid to body (gold plated connectors).....	1.0	N/A
Braid to body (nickel plated connectors).....	2.5	N/A

Corona Level: (Volts min at 70,000 feet)

RG-178 190

RG-316, RG-405 uncabled receptacles, adapters 250

Dummy loads..... N/A

Insertion Loss: (dB max tested at 1 GHz)

Straight cabled connectors, adapters 0.1 dB

Right angle cabled connectors..... 0.2 dB

Uncabled receptacles, dummy loads..... N/A

RF Leakage: (dB min, tested at 2.5 GHz)

Cable connectors -55 dB

Uncabled receptacles and adapters, dummy load N/A

RF High Potential Withstanding Voltage: (VRMS min, tested at 4 and 7 MHz)†

RG-178 500

RG-316 and adapters 700

RG-405 670

Uncabled receptacles..... 600

Dummy loads..... N/A

Power Rating (Dummy Load): 0.5 watt @ +25°C, derated to 0.25 watt @ +125°C

† Avoid user injury due to misapplication. See safety advisory definitions inside front cover.

Mechanical Specifications

Engagement Design: Compatible with CECC 22220, Series MCX

Engagement Force: 5.6 lbs max axial force

Disengagement Force: 8 lbs max axial force, 1 lb min

Contact Retention: 2.3lbs min axial force (captivated contacts) 1 oz-in min torque (uncabled receptacles)

	Axial Force* (lbs)	Torque (oz-in)
RG-178.....	10.0	N/A
RG-316.....	20.0	N/A
RG-316 DS.....	25.0	N/A
RG-405.....	30.0	16

*Or cable breaking strength whichever is less.

Durability: 500 cycles min

Environmental Specifications

(Meets or Exceeds the Applicable Paragraph of MIL-PRF-39012)

Temperature Range:

Connectors..... - 65°C to + 165°C
 Dummy loads - 65°C to + 125°C

Thermal Shock: MIL-STD-202, Method 107, Condition F (N/A dummy loads)

Corrosion: MIL-STD-202, Method 101, Condition B (N/A dummy loads)

Shock: MIL-STD-202, Method 213, Condition B (N/A dummy loads)

Vibration: MIL-STD-202, Method 204, Condition B (N/A dummy loads)

Moisture Resistance: MIL-STD-202, Method 106 (N/A dummy loads)

Material Specifications

- Bodies:** Brass per ASTM B16, gold plated** per MIL-DTL-45204 .00001" min or nickel plated per AMS-QQ-N-290
- Contacts:** Male - brass per ASTM B16, gold plated per MIL-DTL-45204 .00003" min
 Female - beryllium copper per ASTM B196, gold plated per MIL-DTL-45204 .00003" min
- Insulators:** PTFE fluorocarbon per ASTM D 1710 and ASTM D 1457
- Expansion Caps:** Brass per ASTM B16, gold plated per MIL-DTL-45204 .00001" min or nickel plated per AMS-QQ-N-290
- Crimp Sleeves:** Copper per ASTM B301, gold plated per MIL-DTL-45204 .00001" min or nickel plated per AMS-QQ-N-290
- Mounting Hardware:** Brass (nuts) per ASTM B16 or phosphor bronze (lockwashers) per ASTM B139, gold plated per MIL-DTL-45204 .00001" min or nickel plated per AMS-QQ-N-290

** All gold plated parts include a .00005" min. nickel underplate barrier layer.

Mating Engagement for MCX Series Compatible with CECC 22220

1. ID of contact to meet VSWR mating characteristics and connector durability when mated with a dia. .019-.021 (0.48-0.53) male contact.
2. Must meet the force to engage and disengage when mated with mating part.

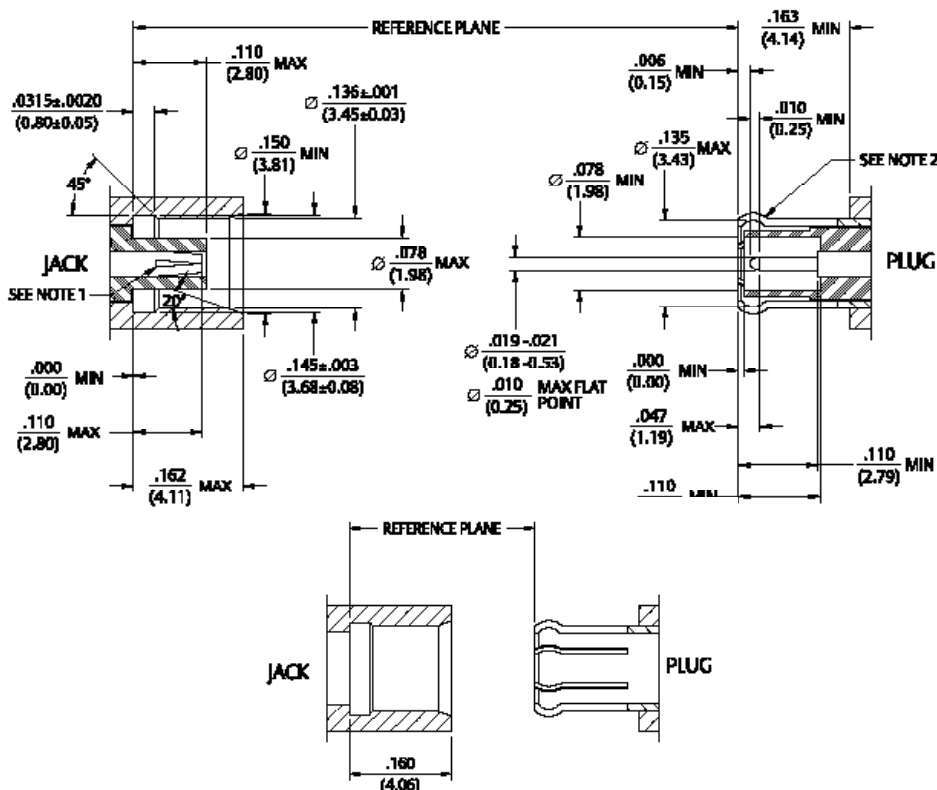

For more information, please contact customer service at (507) 833-8822 or (800) 247-8256 • cinch.com

Illustrations are shown in inches (millimeters).

Semi-Rigid Cable & Flexible Cable

Straight Solder Type Plug

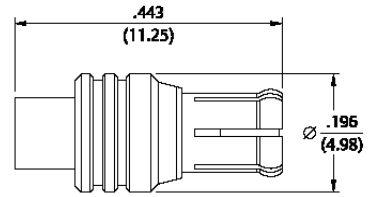

Cable Type	Gold Plated	Nickel Plated
RG-405	133-3693-001	133-3693-006

Assembly instructions page 206.

Right Angle Solder Type Plug – Captivated Contact

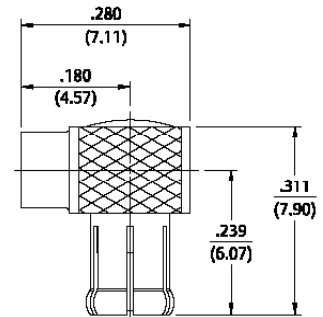

Cable Type	Gold Plated	Nickel Plated
RG-405	133-3693-101	133-3693-106

Assembly instructions page 206.

Straight Crimp Type Plug – Solder or Crimp Contact

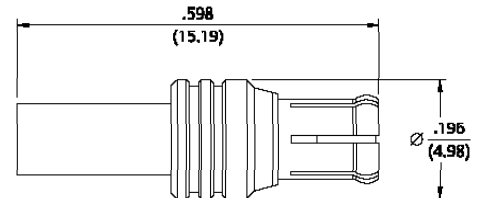

Cable Type	Gold Plated	Nickel Plated	Captivated Contact
RG-178, 196	133-3402-001	133-3402-006	No
RG-316, 188, 161, 174	133-3403-001	133-3403-006	Yes
RG-316 DS, 188DS	133-3404-001	133-3404-006	Yes
RG-179, 187	133-3433-001	133-3433-006	Yes

Assembly instructions page 207.

Right Angle Crimp Type Plug – Captivated Contact

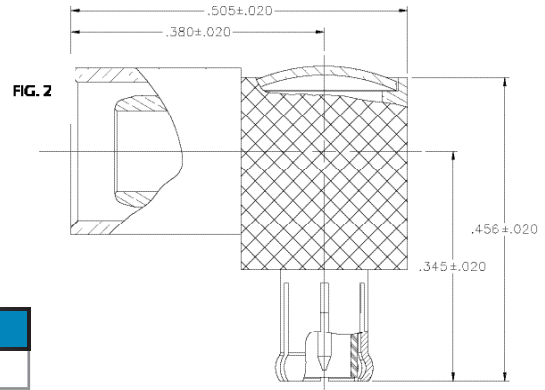
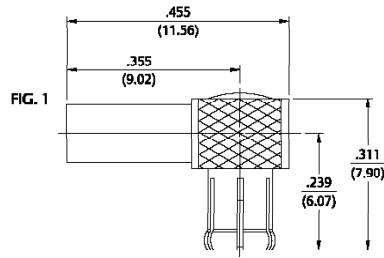

Cable Type	Gold Plated	Nickel Plated	Fig.
RG-178, 196	133-3402-101	133-3402-106	1
RG-316, 188, 161, 174	133-3403-101	133-3403-106	1
RG-316 DS, 188 DS	133-3404-101	133-3404-106	1
RG-58, 303, 141	133-3407-101	133-3407-106	2
RG-179, 187	133-3433-101	133-3433-106	1

Assembly instructions page 210.

Straight Crimp Type Jack – Solder or Crimp Contact

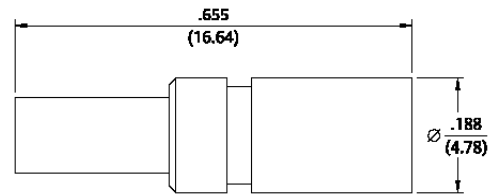

Cable Type	Gold Plated	Nickel Plated	Captivated Contact
RG-178, 196	133-3302-001	133-3302-006	No
RG-316, 188, 161, 174, 179, 187	133-3303-001	133-3303-006	Yes
RG-316 DS, 188 DS	133-3304-001	133-3304-006	Yes

Assembly instructions page 207.

Straight Crimp Type Bulkhead Jack – Solder or Crimp Contact

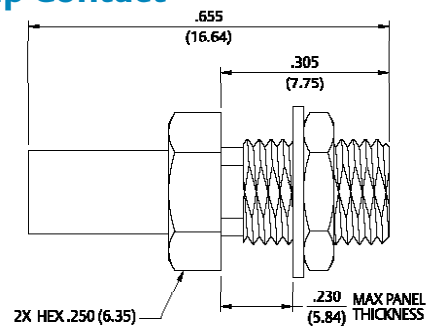

Cable Type	Gold Plated	Nickel Plated	Captivated Contact
RG-178, 196	133-3302-401	133-3302-406	No
RG-316, 188, 161, 174, 179, 187	133-3303-401	133-3303-406	Yes
RG-316 DS, 188 DS	133-3304-401	133-3304-406	Yes

Assembly instructions page 207. Mounting hole layout figure 5 page 194.

For more information, please contact customer service at (507) 833-8822 or (800) 247-8256 • cinch.com

Illustrations are shown in inches (millimeters).

PC Mount

Straight Plug Receptacle



Gold Plated	Nickel Plated
133-3801-201	133-3801-206

Mounting hole layout figure 4 page 194.

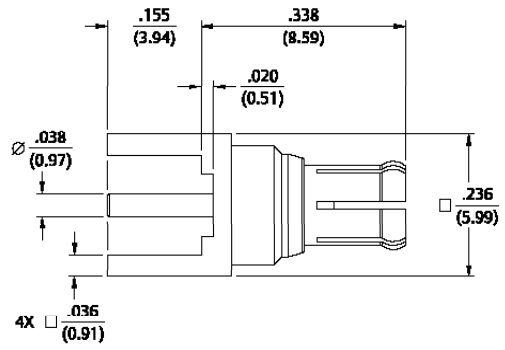

Straight Plug Receptacle – Low Profile



Gold Plated	Nickel Plated
133-3801-211	133-3801-216

Mounting hole layout figure 4 page 194.

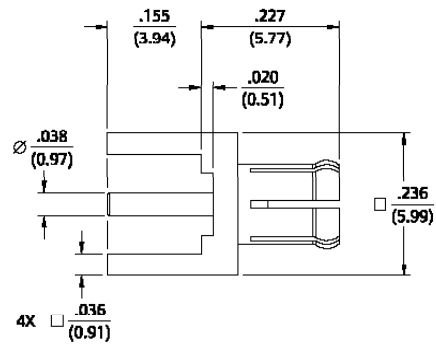

Straight Jack Receptacle



Gold Plated	Nickel Plated	"A"
133-3701-201	133-3701-206	.155 (3.94)
133-3701-211	133-3701-216	.110 (2.79)
133-3701-221	133-3701-226	.068 (1.73)

Mounting hole layout figure 4 page 194.

Four and six connector ganged receptacles available. See page 190.

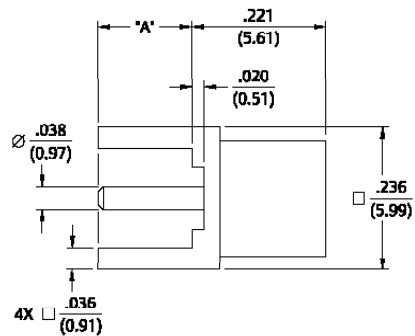

Straight Jack Receptacle – .100” Layout



Gold Plated	Nickel Plated
133-3701-231	133-3701-236

Mounting hole layout figure 12 page 194.

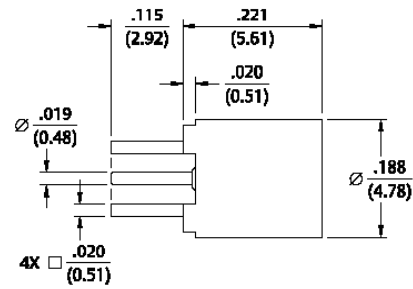

Straight Surface Mount Jack Receptacle



Gold Plated	Packaging
133-3711-201	Stock
133-3711-202	Tape and Reel 750 pcs/reel

Recommended land pattern figure 13 on page 195.
Tape and Reel .315 (8.0) component pitch .630 (16.0) wide.

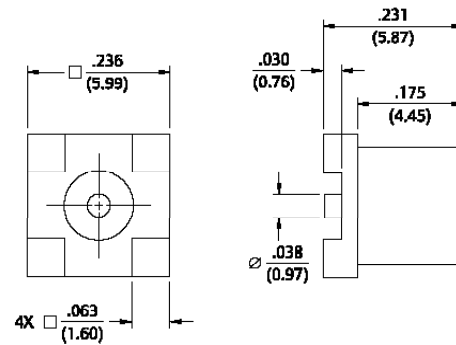

Straight Surface Mount Jack Receptacle



Gold Plated	Packaging
133-3711-211	Stock
133-3711-212	Tape and Reel 750 pcs/reel

Recommended land pattern figure 13 on page 195.
Tape and Reel .472 (12.0) component pitch .630 (16.0) wide.

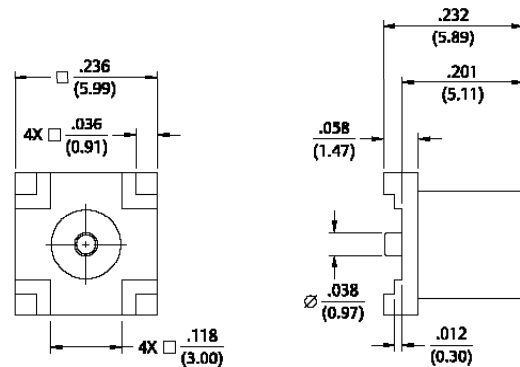

PC Mount

Right Angle Jack Receptacle



Gold Plated	Nickel Plated	"A"
133-3701-301	133-3701-306	.155 (3.94)
133-3701-311	133-3701-316	.110 (2.79)
133-3701-321	133-3701-326	.068 (1.73)

Mounting hole layout figure 4 page 194.

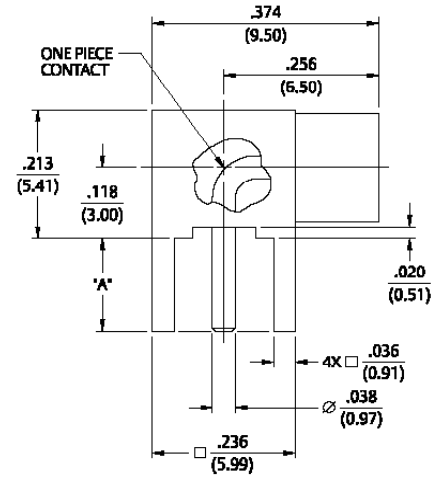

Right Angle Surface Mount Jack Receptacle



Gold Plated	Packaging
133-3711-301	Stock
133-3711-302	Tape and Reel 750 pcs/reel

Recommended land pattern figure 13 on page 195.
Tape and Reel .472 (12.0) component pitch .945 (24.0) wide.

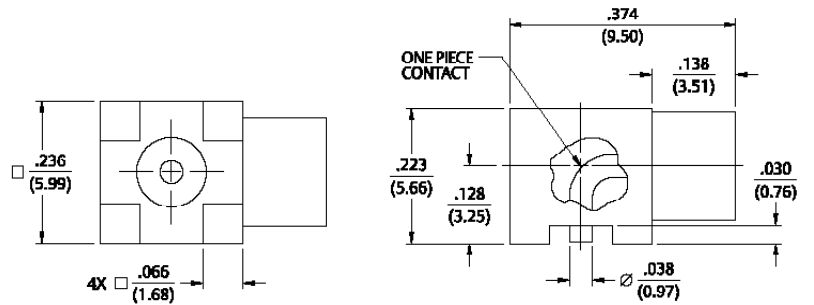

Right Angle Surface Mount Jack Receptacle



Gold Plated	Packaging
133-3711-311	Stock
133-3711-312	Tape and Reel 750 pcs/reel

Recommended land pattern figure 4 on page 194.
Tape and Reel .472 (12.0) component pitch .945 (24.0) wide.

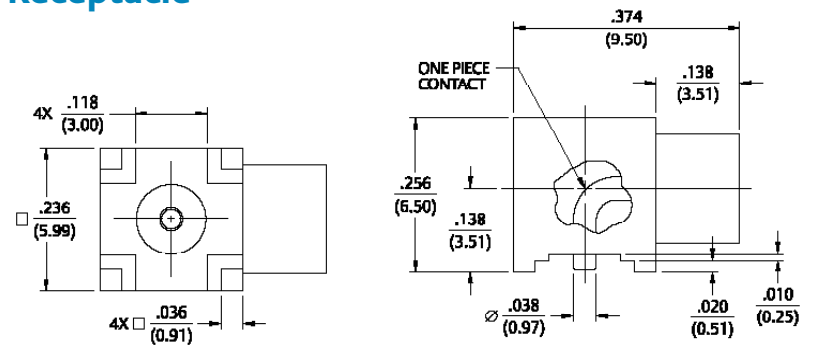

End Launch Plug Receptacle

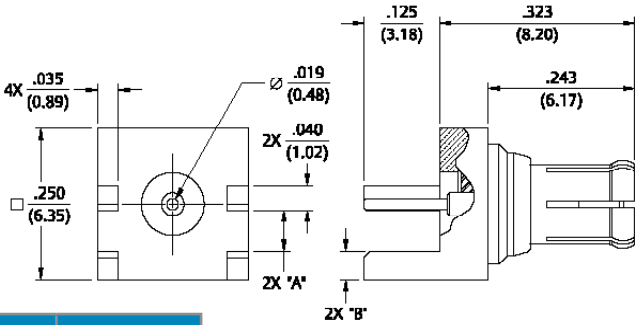

Gold Plated	Nickel Plated	Board Thickness	"A"	"B"
133-3801-841	133-3801-846	.062 (1.57)	.068 (1.73)	.048 (1.22)
133-3801-851	133-3801-856	.042 (1.07)	.048 (1.22)	.068 (1.73)

End Launch Jack Receptacle

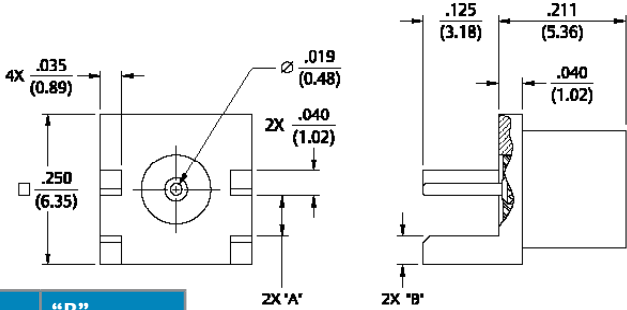

Gold Plated	Nickel Plated	Board Thickness	"A"	"B"
133-3701-801	133-3701-806	.062 (1.57)	.068 (1.73)	.048 (1.22)
133-3701-811	133-3701-816	.042 (1.07)	.048 (1.22)	.068 (1.73)

End Launch Bulkhead Jack Receptacle

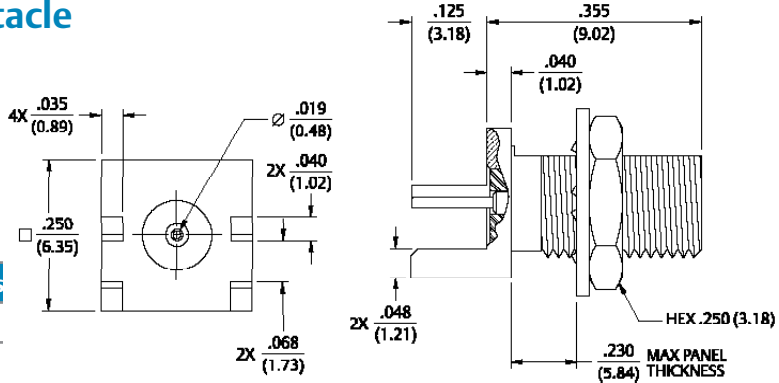

Gold Plated	Nickel Plated	Board Thickness
133-3701-821	133-3701-826	.062 (1.57)

For more information, please contact customer service at (507) 833-8822 or (800) 247-8256 • cinch.com
 Illustrations are shown in inches (millimeters).

PC Mount, Bulkhead Mount & Panel Mount

End Launch Surface Mount Jack Receptacle



Gold Plated	Packaging
133-3711-801	Stock
133-3711-802	Tape and Reel 1000 pcs/reel

Recommended land pattern figure 21 page 195.
Tape and Reel .472 (12.0) component pitch .945 (24.0) wide

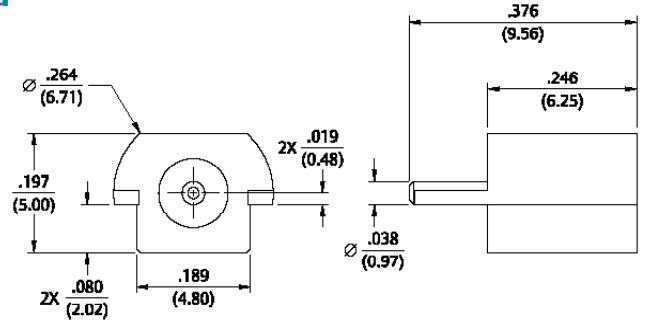

Front Mount Bulkhead Jack Receptacle



Gold Plated	Nickel Plated	Mounting Style	Fig
133-3701-401	133-3701-406	D Flat Threaded	1
133-3701-411	133-3701-416	Press Fit Knurl	2

Mounting hole layout for 133-3701-401 figure 5 page 194.
Mounting hole layout for 133-3701-406 figure 5 page 194.
Mounting hole layout for 133-3701-411 figure 10 page 194.
Mounting hole layout for 133-3701-416 figure 10 page 194.

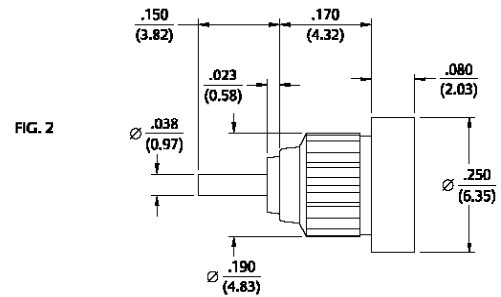
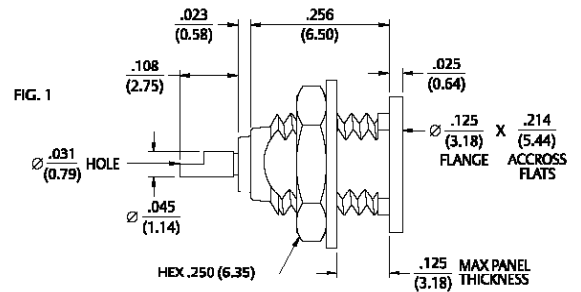

2-Hole Flange Mount Jack Receptacle – Flush Dielectric



Gold Plated	Nickel Plated
133-3701-601	133-3701-606

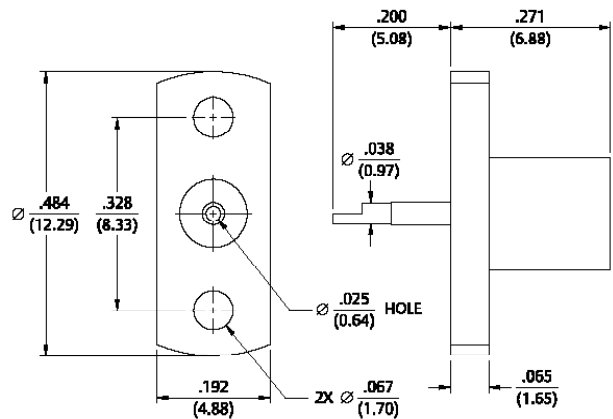

2-Hole Flange Mount Jack Receptacle – Extended Dielectric



Gold Plated	Nickel Plated	"A"	"B"
133-3701-611	133-3701-616	.170 (4.32)	.092 (2.34)
133-3701-621	133-3701-626	.300 (7.62)	.200 (5.08)

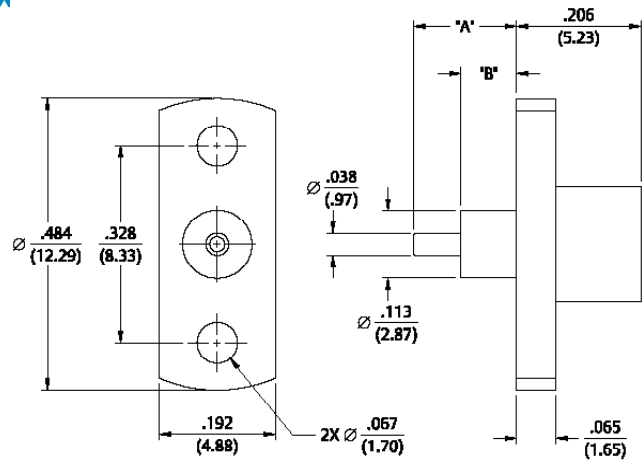

Jack to Jack Adapter



Gold Plated	Nickel Plated
133-3901-801	133-3901-806

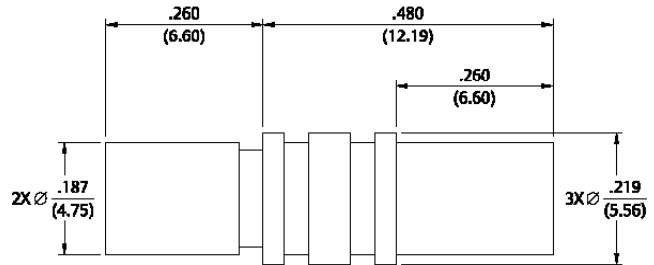

Jack to Bulkhead Jack Adapter



Gold Plated	Nickel Plated
133-3901-401	133-3901-406

Mounting hole layout figure 5 page 194.

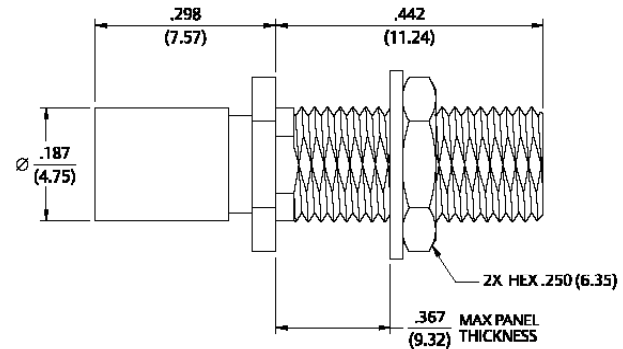

Plug Dummy Load



Freq. Range	Gold Plated	Nickel Plated	Resistance
0-1 GHz	133-3801-801	133-3801-806	50 Ohm
0-1 GHz	133-3801-821	133-3801-826	75 Ohm

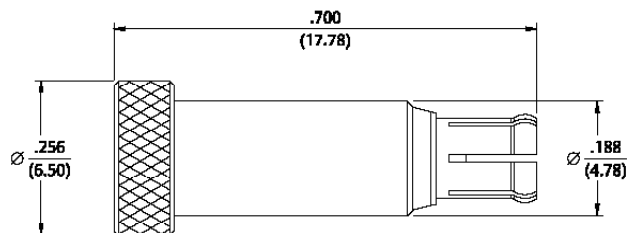

For more information, please contact customer service at (507) 833-8822 or (800) 247-8256 • cinch.com

Illustrations are shown in inches (millimeters).

Specifications

Electrical Specifications

Impedance:	50 Ohms	
Frequency Range:	0-6 GHz	
VSWR (max): (f = GHz)	Straight Cabled Connectors	Right Angle Cabled Connectors
RG-178	1.17 + .04f	1.07 + .06f
RG-316	1.13 + .04f	1.07 + .04f
Uncabled receptacles	N/A	
Working Voltage: (VRMS max)†	Sea Level	70K Feet
RG-178	.250	65
RG-316	.335	85
Dielectric Withstanding Voltage: (VRMS min at sea level)†		
RG-178	750	
RG-316, uncabled receptacles	1000	
Corona Level: (Volts min at 70,000 feet)		
RG-178	190	
RG-316, uncabled receptacles	250	
Insertion Loss: (dB max tested at 1 GHz)		
Straight cabled connectors	0.1 dB	
Right angle cabled connectors	0.2 dB	
Uncabled receptacles	N/A	
Insulation Resistance:	1000 megohms min	
Contact Resistance: (milliohms max)	Initial	After Environmental
Center contact (straight cabled connectors and uncabled receptacles)	5.0	8.0
Center contact (right angle cabled connectors)	5.0	15.0
Outer contact (all connectors)	1.0	1.5
Braid to body (gold plated connectors)	1.0	N/A
Braid to body (nickel plated connectors)	2.5	N/A
RF Leakage: (dB min, tested at 2.5 GHz)		
Cable connectors	-55 dB	
Uncabled receptacles	N/A	
RF High Potential Withstanding Voltage: (VRMS min tested at 4 and 7 MHz) †		
RG-178	500	
RG-316	700	
Uncabled receptacles	600	

† Avoid user injury due to misapplication. See safety advisory definitions.

Mechanical Specifications

Engagement Force:	5.6 lbs max axial force	
Disengagement Force:	8 lbs max axial force, 1 lbs min.	
Contact Retention:	2.3 lbs min axial force (captivated contacts) 1 oz-in min torque (uncabled receptacles)	
Cable Retention:	Axial Force* (lbs)	Torque (oz-in)
RG-178	10.0	N/A
RG-316	20.0	N/A
RG-316 DS	25.0	N/A
*Or cable breaking strength whichever is less.		
Durability:	500 cycles min	

Environmental Specifications

(Meets or Exceeds the Applicable Paragraph of MIL-PRF-39012)

Temperature Range:	- 65°C to + 165°C
Thermal Shock:	MIL-STD-202, Method 107, Condition F
Corrosion:	MIL-STD-202, Method 101, Condition B
Shock:	MIL-STD-202, Method 213, Condition B
Vibration:	MIL-STD-202, Method 204, Condition B
Moisture Resistance:	MIL-STD-202, Method 106

Material Specifications

Bodies:	Brass per ASTM B16 or zinc per ASTM B86-71, gold plated** per MIL-DTL-45204 .00001" min or nickel plated per AMS-QQ-N-290
Contacts:	Male - brass per ASTM B16, gold plated per MIL-DTL-45204 .00003" min Female - beryllium copper per ASTM B196, gold plated per MIL-DTL-45204 .00003" min
Insulators:	PTFE fluorocarbon per ASTM D 1710 and ASTM D 1457
Expansion Caps:	Brass per ASTM B16, gold plated per MIL-DTL-45204 .00001" min or nickel plated per AMS-QQ-N-290
Crimp Sleeves:	Copper per ASTM B301, gold plated per MIL-DTL-45204 .00001" min or nickel plated per AMS-QQ-N-290
Mounting Hardware:	Brass (nuts) per ASTM B16 or phosphor bronze (lockwashers) ASTM B139, gold plated per MIL-DTL-45204 .00001" min or nickel plated per AMS-QQ-N-290

** All gold plated parts include a .00005" min. nickel underplate barrier layer.

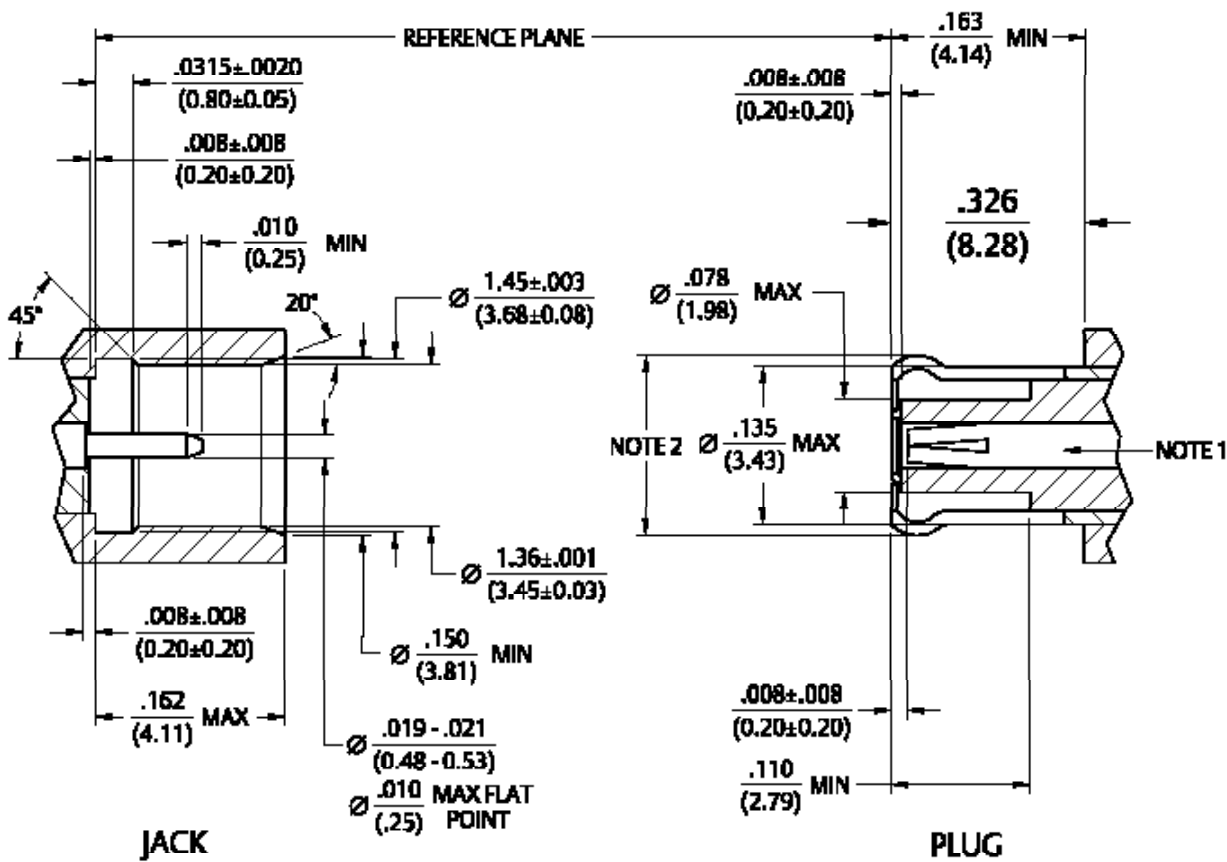

Notes:

1. ID of contact to meet VSWR mating charac
2. Must meet the force to engage and disengage when mated with mating part.

For more information, please contact customer service at (507) 833-8822 or (800) 247-8256 • cinch.com

Illustrations are shown in inches (millimeters).

Flexible Cable

Straight Crimp Type Plug – Solder or Crimp Contact

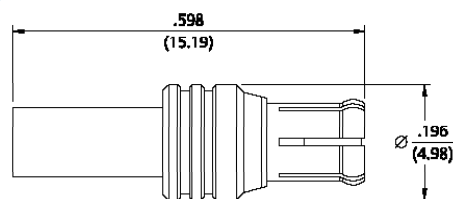

Cable Type	Gold Plated	Nickel Plated	Captivated Contact
RG-178, 196	133-5402-001	133-5402-006	No
RG-316, 188, 161, 174	133-5403-001	133-5403-006	Yes
RG-316 DS, 188 DS	133-5404-001	133-5404-006	Yes

Assembly instructions page 207.

Right Angle Crimp Type Plug – Captivated Contact

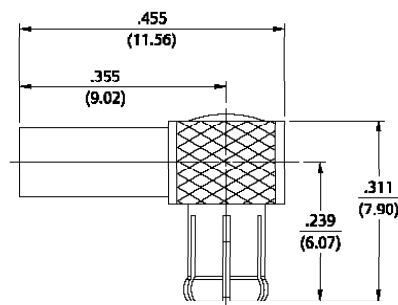

Cable Type	Gold Plated	Nickel Plated
RG-178, 196	133-5402-101	133-5402-106
RG-316, 188, 161, 174	133-5403-101	133-5403-106
RG-316 DS, 188 DS	133-5404-101	133-5404-106

Assembly instructions page 210.

Straight Crimp Type Bulkhead Jack – Solder or Crimp Contact

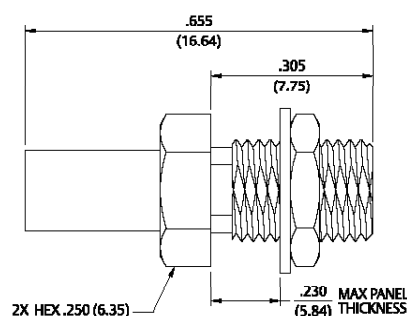

Cable Type	Gold Plated	Nickel Plated	Captivated Contact
RG-178, 196	133-5302-401	133-5302-406	No
RG-316, 188, 161, 174	133-5303-401	133-5303-406	Yes
RG-316 DS, 188 DS	133-5304-401	133-5304-406	Yes

Mounting hole layout figure 5 page 194.
 Assembly instructions page 207.

Straight Jack Receptacle



Gold Plated	Nickel Plated
133-5701-201	133-5701-206

Mounting hole layout figure 4 page 194.

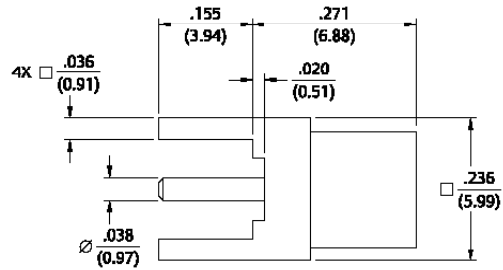

End Launch Bulkhead Jack Receptacle



Gold Plated	Nickel Plated
133-5701-801	133-5701-806

Mounting hole layout figure 4 page 194.

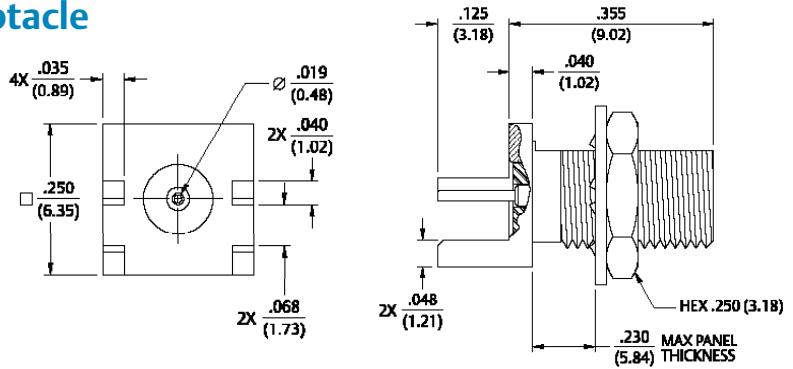

Specifications

Electrical Specifications

Impedance: 75 Ohms

Frequency Range: 0-6 GHz

VSWR: (max) (f = GHz)

	<u>Straight Cabled Connectors</u>	<u>Right Angle Cabled Connectors</u>
RG-179	1.13 + .04f	1.07 + .04f
In-series adapters	1.07 + .03f	
Between-series adapters, loads	1.05 + .01f	

Uncabled receptacles N/A

Working Voltage: (VRMS max)† Sea Level 70K Feet

RG-179 335 85

Uncabled receptacles, adapters 335 85

Loads, matching pad..... N/A

Dielectric Withstanding Voltage: (VRMS min at sea level)†

RG-1791000

Uncabled receptacles, adapters1000

LoadsN/A

Insulation Resistance: 1,000 megohms min

Contact Resistance: (milliohms max)

	<u>Initial</u>	<u>After Environmental</u>
Center contact (straight cabled connectors and uncabled receptacles)	5.0	8.0
Center contact (right angle cabled connectors, adapters).....	10.0	15.0
Center contact (loads).....	N/A	
Outer contact.....	1.0	1.5
Braid to body (gold plated connectors).....	1.0	N/A

Corona Level: (Volts min at 70,000 feet) †

RG-179250

Uncabled receptacles, adapters250

Loads matching pad..... N/A

Insertion Loss: (dB max tested at 1 GHz)

Straight cabled connectors 0.1 dB

Right angle cabled connectors 0.2 dB

Uncabled receptacles, adapters N/A

RF Leakage: (dB min, tested at 2.5 GHz)

Cable connectors -55 dB typical

Uncabled receptacles, adapters, loads N/A

RF High Potential Withstanding Voltage: (VRMS min, tested at 4 and 7 MHz)†

Cabled Connectors for RG-179 700

Uncabled receptacles, adapters 600

Loads N/A

Power Rating: (Loads) 1.0 Watt at +25°C, derated linearly to 0.5 Watts at +125°C

† Avoid user injury due to misapplication. See safety advisory definitions inside front cover.

Mechanical Specifications

Engagement Design:	Compatible with CECC 22220, Series MCX 50 Ohm	
Engagement Force:	5.6 lbs max axial force	
Disengagement Force:	8 lbs max axial force, 1 lb min	
Contact Retention:	2.3 lbs min axial force (captivated contacts) 1 oz-in - min torque (uncabled receptacles)	
	<u>Axial Force (lbs) *</u>	<u>Torque (oz-in)</u>
RG-179, BELDEN 735A	20.0	N/A
RG-179 DS	25.0	N/A
*Or cable breaking strength whichever is less.		
Durability:	500 cycles min	

Environmental Specifications

(Meets or Exceeds the Applicable Paragraph of MIL-PRF-39012)

Temperature Range:	
All Connectors, Adapters	- 65°C to + 165°C
Loads	- 65°C to + 125°C
Thermal Shock:	MIL-STD-202, Method 107, Condition F (N/A Loads)
Temperature Coefficient:	Loads +/- 300ppm/°C
Corrosion:	MIL-STD-202, Method 101, Condition B (N/A Loads)
Shock:	MIL-STD-202, Method 213, Condition B (N/A Loads)
Vibration:	MIL-STD-202, Method 204, Condition B (N/A Loads)
Moisture Resistance:	MIL-STD-202, Method 106 (N/A Loads)

Material Specifications

Bodies:	Brass per ASTM B16, gold plated** per MIL-DTL-45204 .00001" min or stainless steel, type 303 per ASTM A582, passivated per MIL-F-14072 (EL70)
Contacts:	Male - brass per ASTM B16, gold plated per MIL-DTL-45204 .00003" min Female - beryllium copper per ASTM B196, gold plated per MIL-DTL-45204 .00003" min
Insulators:	PTFE fluorocarbon per ASTM D 1710 and ASTM D 1457
Expansion Caps:	Brass per ASTM B16, gold plated per MIL-DTL-45204 .00001" min
Crimp Sleeves:	Copper, gold plated per MIL-DTL-45204 .00001" min
Mounting Hardware:	Brass (nuts) per ASTM B16 or phosphor bronze (lockwashers) ASTM B139, gold plated per MIL-DTL-45204 .00001" min

** All gold plated parts include a .00005" min. nickel underplate barrier layer.

Specifications

Mating Engagement for 75 Ohm MCX Series (Intermatable with CECC22220 50 Ohm MCX)

1. ID of contact to meet VSWR mating characteristics and connector durability when mated with a dia. .019-.021 (0.48-0.53) dia. male contact.
2. Must meet the force to engage and disengage when mated with mating part.
3. Interface shall intermiate with MCX 50 Ohm interface per CECC 22220.

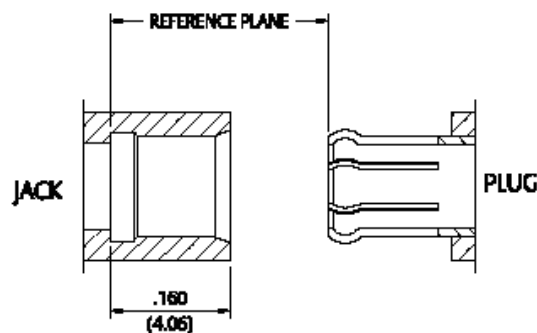
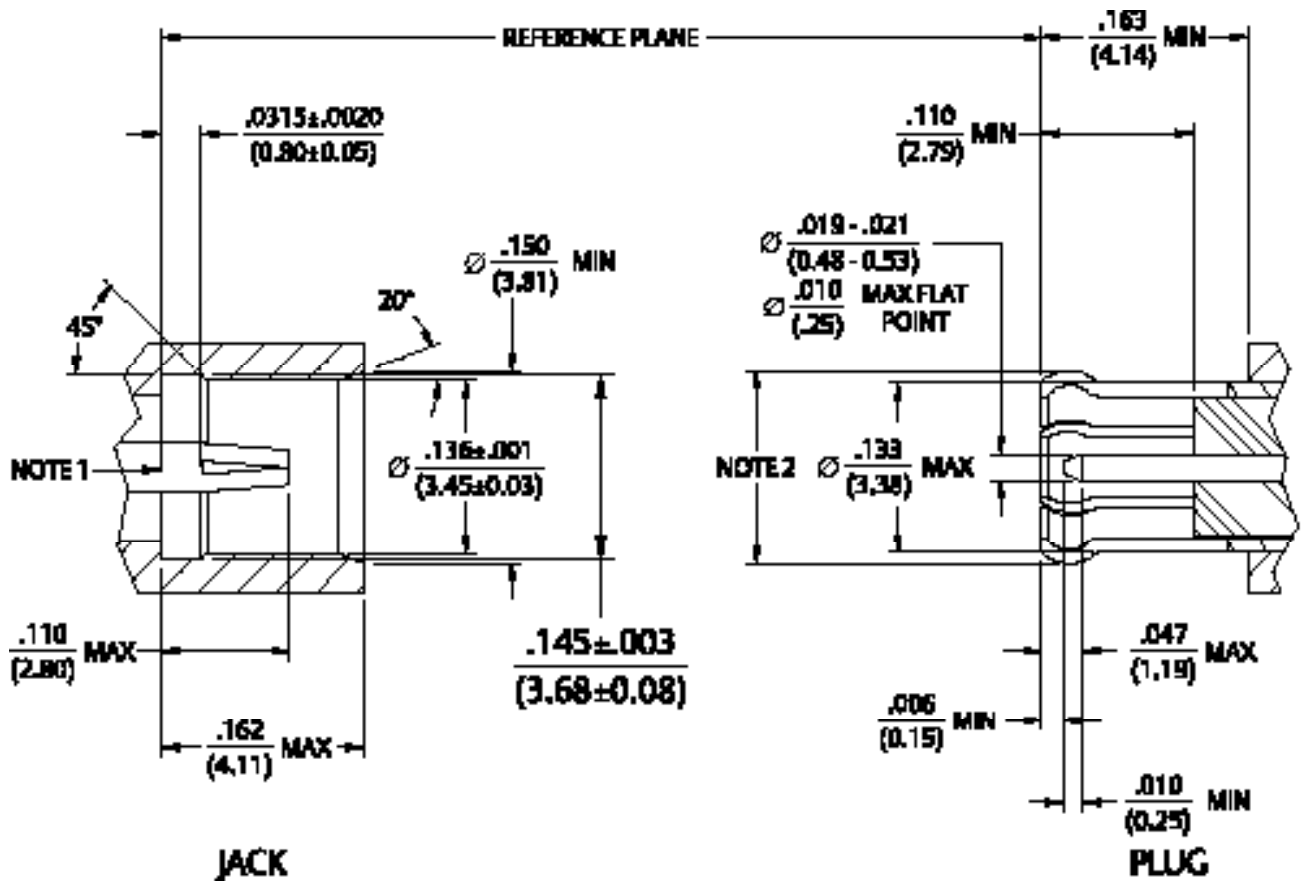

Straight Crimp Type Plug – Solder or Crimp Captivated Contact

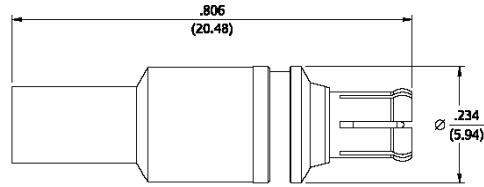

Cable Type	Gold Plated
RG-179	133-8433-001
RG-179 DS	133-8434-001
Belden 735A	133-8445-001

Assembly instructions page 209.

Right Angle Crimp Type Plug – Captivated Contact

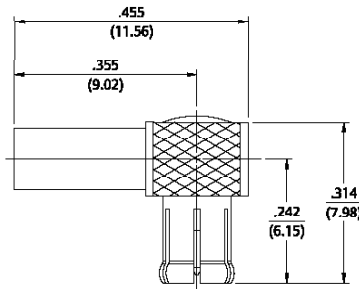

FIG. 1

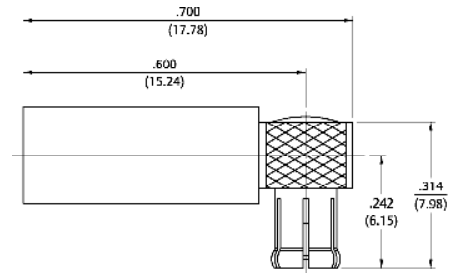
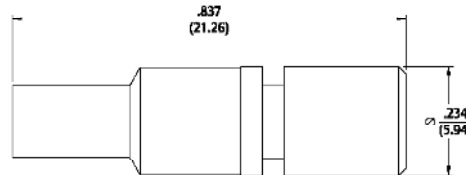

FIG. 2

Cable Type	Gold Plated	Fig
RG-179	133-8433-101	1
RG-179 DS	133-8434-101	1
Belden 735A	133-8445-101	2

Assembly instructions page 211.

Straight Crimp Type Jack – Solder or Crimp Captivated Contact



Cable Type	Gold Plated
RG-179	133-8333-001
RG-179 DS	133-8334-001

Assembly instructions page 209.

For more information, please contact customer service at (507) 833-8822 or (800) 247-8256 • cinch.com

Illustrations are shown in inches (millimeters).

Flexible Cable & PC Mount

Straight Crimp Type Bulkhead Jack – Solder or Crimp Captivated Contact



Cable Type	Gold Plated
RG-179	133-8333-401
RG-179 DS	133-8334-401

Assembly instructions page 209.
Mounting hole layout figure 5 page 194.

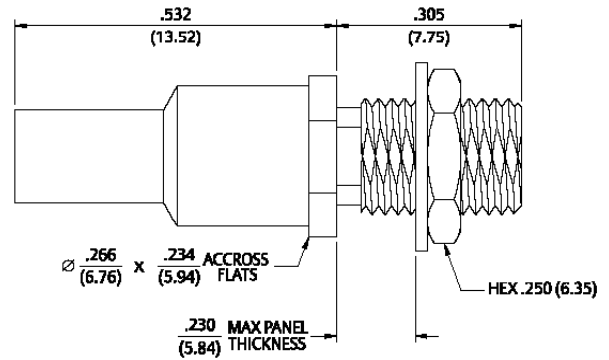

Straight Plug Receptacle



Gold Plated	"A"	"B"
133-8801-201	.155 (3.80)	.343 (8.71)
133-8801-211	.110 (2.70)	.343 (8.71)
133-8801-221	.155 (3.80)	.510 (12.95)

Mounting hole layout figure 20 page 195.

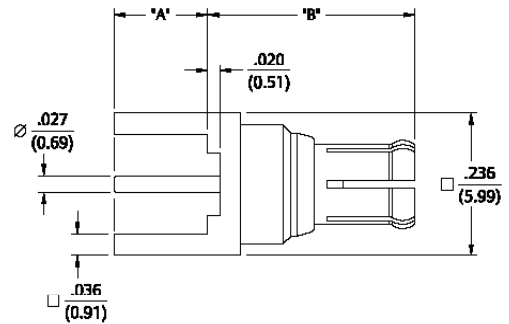

Straight Jack Receptacle



Gold Plated	"A"
133-8701-201	.155 (3.80)
133-8701-211	.100 (2.54)

Mounting hole layout figure 20 page 195.

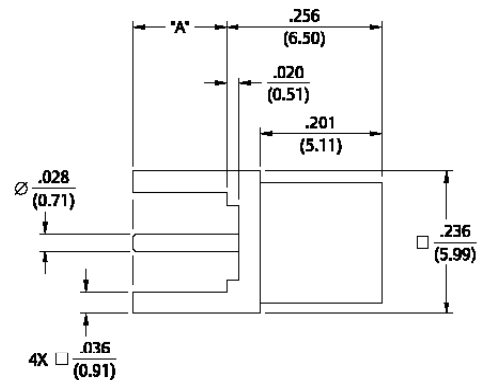

Surface Mount Jack Receptacle



Gold Plated	Packaging
133-8711-201	Bulk Packs
133-8711-202	Tape and Reel 770 pcs/reel

Mounting hole layout figure 11 page 194.
Tape and Reel .472 (12.0) component pitch .630 (16.0) wide.

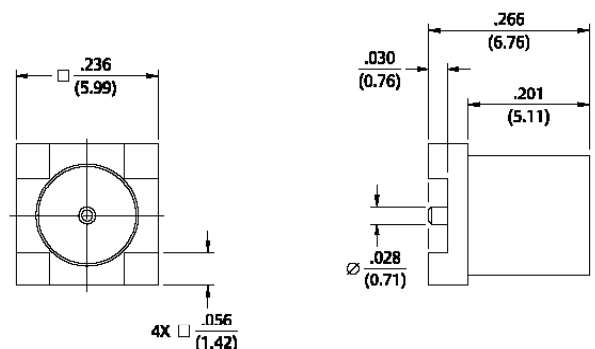

Right Angle Jack Receptacle



Gold Plated	"A"
133-8701-301	.155 (3.80)
133-8701-311	.110 (2.70)

Mounting hole layout figure 20 page 195.

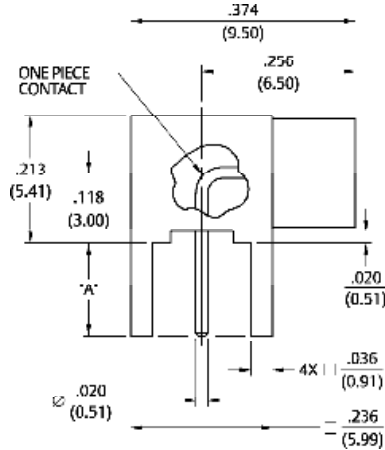

End Launch Jack Receptacle



Cable Type	Board Thickness
133-8701-801	.062 (1.57)

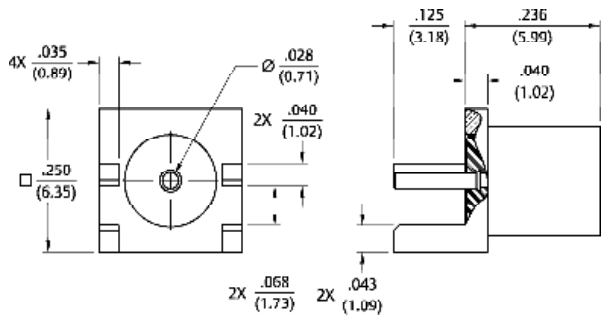

Bulkhead Mount & In-Series Adapters

Bulkhead Jack Receptacle



Gold Plated
133-8701-401

Mounting hole layout figure 1 page 194.

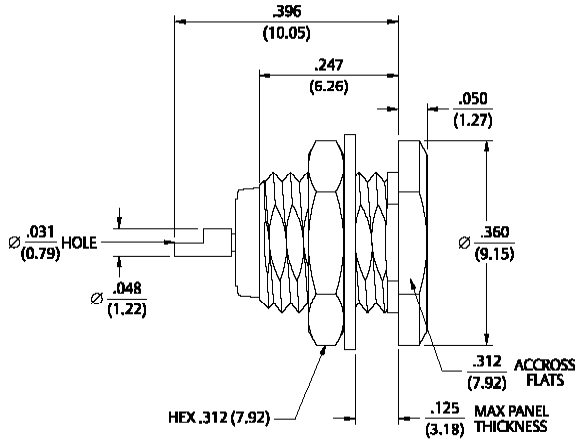

Jack to Jack Adapter



Gold Plated
133-8901-801

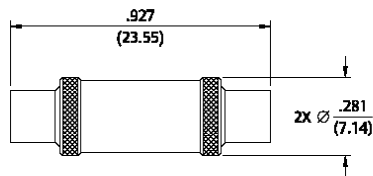

For more information, please contact customer service at (507) 833-8822 or (800) 247-8256 • cinch.com
 Illustrations are shown in inches (millimeters).

In-Series Adapters & Between Series Adapters

Jack to Plug Adapter



Gold Plated

133-8901-821

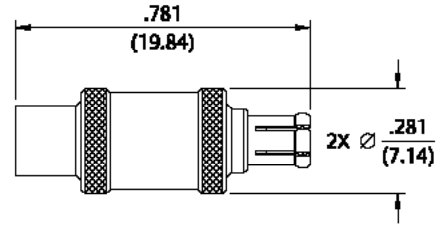

75 Ohm Type N Plug to 75 Ohm MCX Plug Adapter



Stainless Steel Passivated

134-1068-001

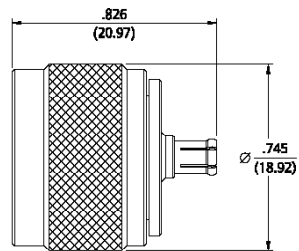

75 Ohm Type N Plug to 75 Ohm MCX Jack Adapter



Stainless Steel Passivated

134-1068-011

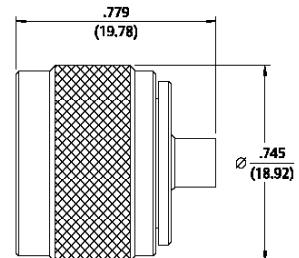

75 Ohm Type N Jack to 75 Ohm MCX Plug Adapter



Stainless Steel Passivated

134-1068-021

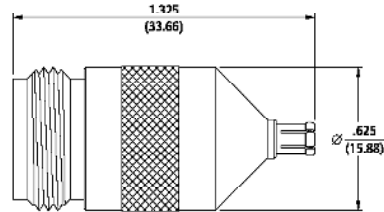

75 Ohm Type N Jack to 75 Ohm MCX Jack Adapter



Stainless Steel Passivated

134-1068-031

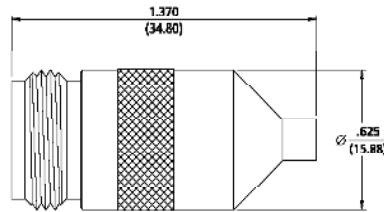

Plug Precision Load



Gold Plated

133-8801-831

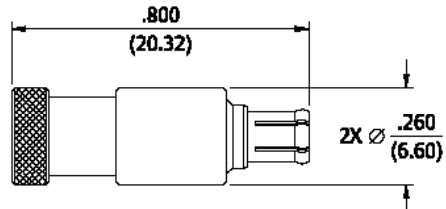

Jack Precision Load



Gold Plated

133-8701-831

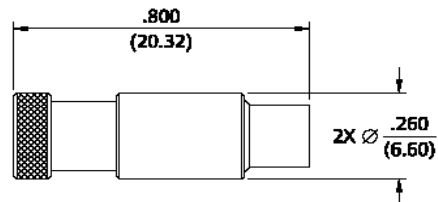

For more information, please contact customer service at (507) 833-8822 or (800) 247-8256 • cinch.com
Illustrations are shown in inches (millimeters).

Specifications

Electrical Specifications

Impedance: 50 Ohms
Frequency Range: 0-6 GHz
VSWR (max): (f = GHz)

	Straight Cabled Connectors	Right Angle Cabled Connectors
RG-316 cable.....	1.13 + .04f	1.07 + .04f
Uncabled receptacles		N/A
Working Voltage: (VRMS max)†	<u>Sea Level</u>	<u>70K Feet</u>
RG-316	335	85
Dielectric Withstanding Voltage: (VRMS min at sea level)†		
RG-316, uncabled receptacles		1000
Insulation Resistance: 1,000 megohms min		
Contact Resistance: (milliohms max)		After
	<u>Initial</u>	<u>Environmental</u>
Center contact (straight cabled connectors and uncabled receptacles)	5.0	8.0
Center contact (right angle cabled connectors)	5.0	15.0
Outer contact.....	1.0	1.5
Braid to body	1.0	N/A
Corona Level: (Volts min at 70,000 feet) †		
RG-316, uncabled receptacles		250
Insertion Loss: (dB max tested at 1 GHz)		
Straight cabled connectors		0.1 dB
Right angle cabled connectors.....		0.2 dB
Uncabled receptacles.....		N/A
RF Leakage: (dB min, tested at 2.5 GHz)		
Cabled connectors.....		-55 dB
Uncabled receptacles		N/A
RF High Potential Withstanding Voltage: (VRMS min tested at 4 and 7 MHz)		
Cabled Connectors		700
Uncabled receptacles.....		600

† Avoid user injury due to misapplication. See safety advisory definitions.

Mechanical Specifications

Engagement Design: Compatible with CECC 22220, Series MCX 50 Ohm
Engagement Force: 5.6 lbs max axial force
Disengagement Force: 8 lbs max axial force, 1 lb min
Contact Retention: 2.3 lbs min axial force (captivated contacts) 1 oz-in min torque (uncabled receptacles)

	Axial Force (lbs) *	Torque (oz-in)
RG-316	20.0	N/A
RG-316 DS.....	25.0	N/A

*Or cable breaking strength whichever is less.

Durability: 500 cycles min

Environmental Specifications

(Meets or Exceeds the Applicable Paragraph of MIL-PRF-39012)

Temperature Range: - 65°C to + 165°C
Thermal Shock: MIL-STD-202, Method 107, Condition F
Corrosion: MIL-STD-202, Method 101, Condition B
Shock: MIL-STD-202, Method 213, Condition B
Vibration: MIL-STD-202, Method 204, Condition B
Moisture Resistance: MIL-STD-202, Method 106

Material Specifications

(See non-magnetic materials page 10)

Straight Crimp Type Plug – Solder or Crimp Contact – Captivated Contact

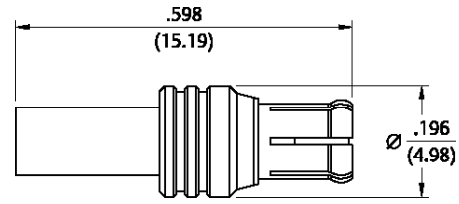

Cable Type	Gold Plated
RG-316, 188, 174	133-9403-001
RG-316 DS, 188 DS	133-9404-001

Assembly instructions page 208.

Right Angle Crimp Type Plug – Captivated Contact

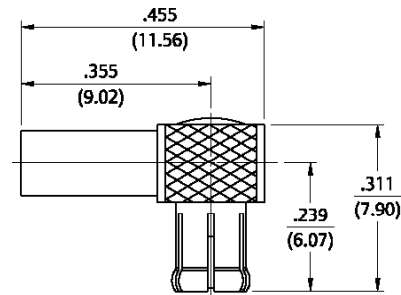

Cable Type	Gold Plated
RG-316, 188, 174	133-9403-101
RG-316 DS, 188 DS	133-9404-101

Assembly instructions page 207.

Non-Magnetic RF Connectors – For PC Mount

Straight Jack Receptacle



Gold Plated	"A"
133-9701-201	.155 (3.94)
133-9701-211	.110 (2.79)

Mounting hole layout figure 4 page 194.

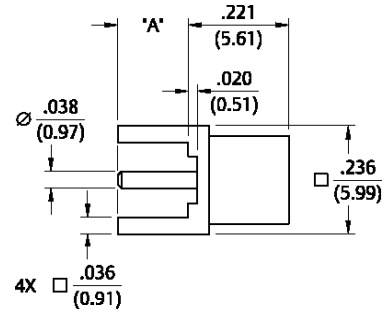

Straight Jack Receptacle – .100" Layout



Gold Plated
133-9701-231

Mounting hole layout figure 12 page 194.

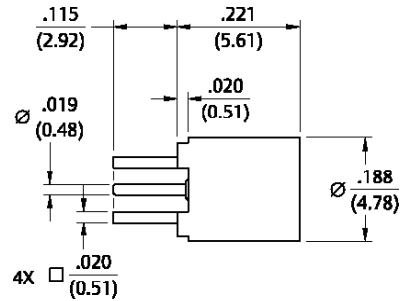

Right Angle Jack Receptacle



Gold Plated	"A"
133-9701-301	.155 (3.94)
133-9701-311	.110 (2.79)

Mounting hole layout figure 4 page 194.

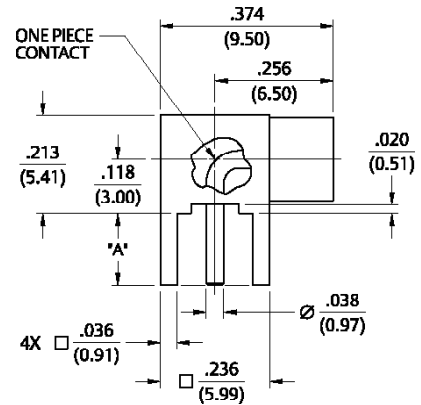

End Launch Jack Receptacle – Round Contact



Gold Plated	Board Thickness
133-9701-801	.062 (1.57)

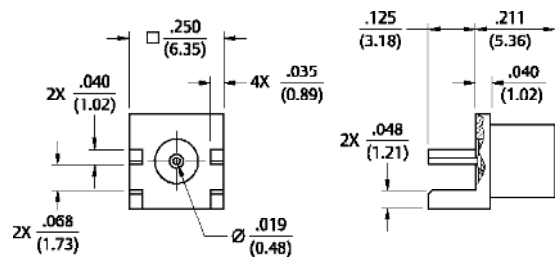

SMK Connectors

50 Ohm Connectors	
Specifications.....	40
Semi-Rigid & Flexible Cable	43
Adapters	44
Other Information	
Assembly Tools	185
Capabilities	190
Cable Information	192
Assembly Instruction	193
Mounting Hole Layouts	194
Numerical Index	274
Competitor Cross Reference	280

3	MMCX Connectors
13	MCX Connectors
39	SMK Connectors
45	SMA Connectors
103	SMB Connectors
131	SMC Connectors
137	SMP Connectors
145	Type N Connectors
153	Shielded Cable Terminations
157	Between-Series Adapters
161	Fixed Length Cable Assemblies
173	Ultra Miniature Connectors (UMC)
181	kwiQMate™ Connectors
185	Tools
193	Assembly Instructions
257	Electronic Hardware
274	Index

While every precaution has been taken to ensure accuracy and completeness herein, Cinch Connectivity Solutions assumes no responsibility, and disclaims all liability for damages resulting from use of this information or for any errors or omissions. Specifications subject to change without notice.

Specifications

SMK (2.92mm) Connectors

The Johnson line of SMK Connectors provides an excellent solution for demanding applications requiring high frequency transmission. Although similar to the SMA interface, a smaller internal body diameter (2.92mm) and air dielectric provide a higher cutoff frequency and other key advantages:

- Precision manufacturing allows superior electrical performance to 40 GHz
- Female contacts have a unique three-slot construction, which enhances connectivity by creating a more rugged connector while reducing the chance of intermittent connections
- Precise assembly tooling assures excellent, repeatable contact and support bead location on cabled connectors
- Connector mating interface per MIL-STD-348
- Mating interface control provides consistent electrical performance
- Plug connector VSWR is 1.20 Max to 40 GHz and a 12 inch SMK plug to plug cable assembly performs better than 1.35 VSWR to 40 GHz
- Field Replaceable Jacks are teamed with a high quality hermetic seal feed thru for use in sealed circuit modules
- SMK plug interface employs more precise dimensions than an SMA and uses a shorter snub nose male pin such that the connector bodies align before the contacts engage



Electrical Specifications

Impedance: 50 Ohms

Frequency Range: 0-40 GHz

VSWR (max): (f = GHz)

Semi-Rigid straight cabled connectors and adapters	1.20 max
Field replaceable (see typical return loss graph)	N/A

Working Voltage: (VRMS max)

Connectors for Cable Type	Sea Level	70K Feet
RG-405 and field replaceable.....	335	85
RG-402 and adapters.....	500	125

Dielectric Withstanding Voltage: (VRMS min at sea level)

RG-405 and field replaceable.....	1000
RG-402 and adapters.....	1500

Corona Level: (Volts min at 70,000 feet)

RG-405 and field replaceable.....	250
RG-402 and adapters.....	375

Insertion Loss: (dB max)

Adapters	0.06 f (GHz), tested at 6 GHz
Straight Semi-Rigid cable connectors	0.03 f (GHz), tested at 10 GHz

Insulation Resistance: 5000 megohms min

Contact Resistance: (milliohms max)

	Initial	After Environmental
Center contact straight cabled connectors	3.0*	4.0
Center contact adapters	4.0	6.0
Field replaceable connectors.....	6.0	8.0
Outer contact (all connectors).....	2.0	N/A
Body to cable (gold plated connectors)	0.5	N/A
Body to cable (passivated connectors)	5.0	N/A

RF Leakage: (dB min, tested at 2.5 GHz)

RF High Potential Withstanding Voltage: (VRMS min., tested at 4 and 7 MHz)†

RG-405 and field replaceable.....	670
RG-402 and adapters.....	1000

Mechanical Specifications

Engagement Design: MIL-STD-348, Series SMK (2.92mm)

Engagement/Disengagement Force: 2 lb-in max

Mating Torque: 7 to 10 in-lb

Bulkhead Mounting Nut Torque: 15 in-lb

Coupling Proof Torque: 15 in-lb min

Coupling Nut Retention: 60 lbs min

Contact Retention: 6 lbs min axial force (captivated contacts)

Cable Retention:

	Axial Force* (lbs)	Torque (in-oz)
RG-405.....	30	16
RG-402.....	60	55

*Or cable breaking strength whichever is less

Durability: 500 cycles min

† Avoid user injury due to misapplication. See safety advisory definitions.

Environmental Specifications

(Meets or Exceeds the Applicable Paragraph of MIL-PRF-C-39012)

Temperature Range: - 65°C to + 165°C

Thermal Shock: MIL-STD-202, Method 107, Condition B

Corrosion: MIL-STD-202, Method 101, Condition B

Shock: MIL-STD-202, Method 213, Condition I

Vibration: MIL-STD-202, Method 204, Condition D

Moisture Resistance: MIL-STD-202, Method 106

Material Specifications

Bodies: Stainless steel per ASTM B16, gold plated* per MIL-G-45204 .00005" min. or passivated per MIL-DTL-14072

Contacts: Female - beryllium copper per ASTM B1960, gold plated per MIL-DTL- G-45204 .00005" min

Contact Support Beads: PTFE fluorocarbon per ASTM D 1710 and ASTM D 1457 or modified PPE resin

Seal Rings: Silicone rubber per ZZ-R-765

* All gold plated parts include a .00005" min. nickel underplate barrier layered

Mating Engagement for SMK (2.92mm) Series

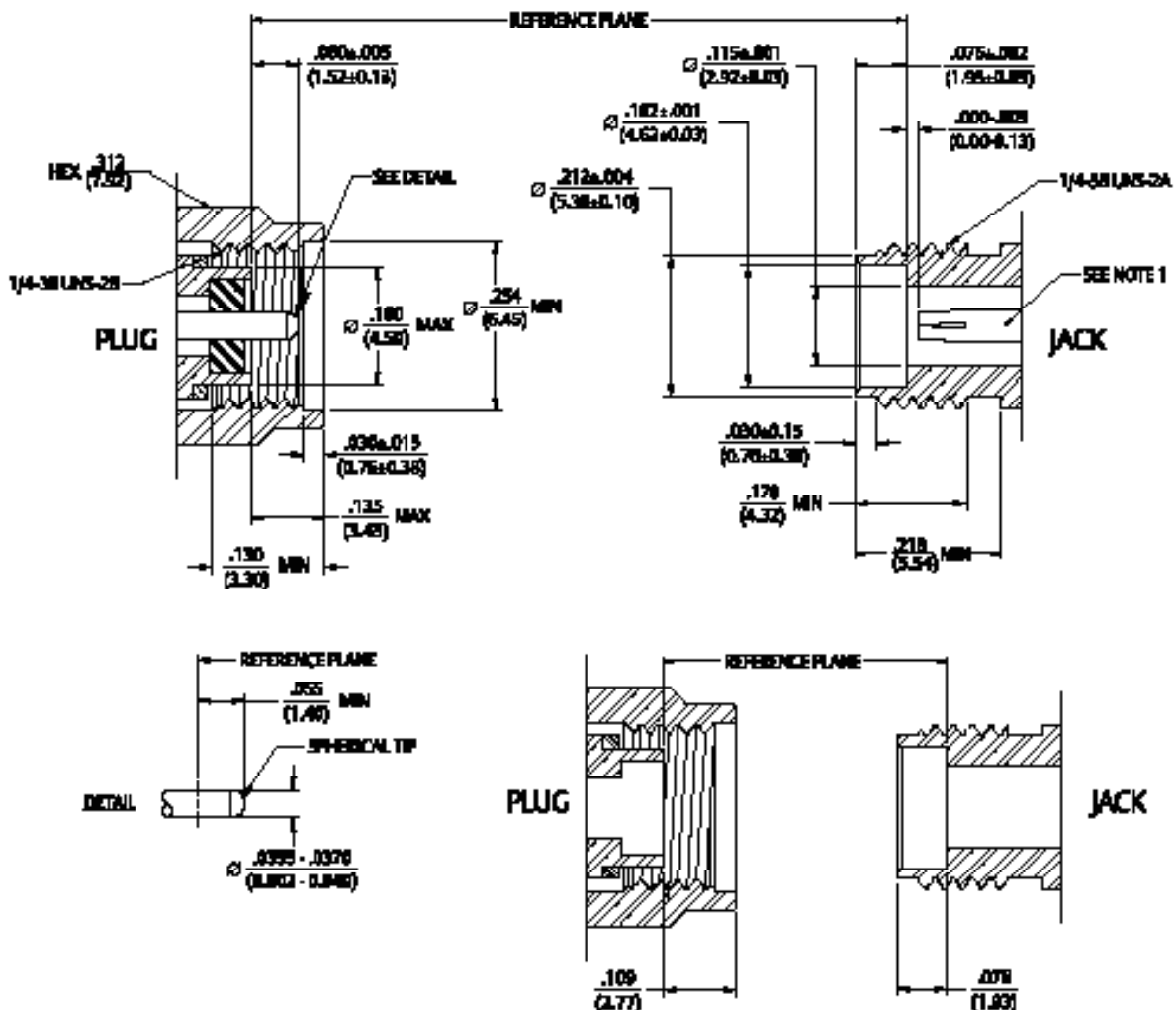

Notes:

1. ID of contact shall meet VSWR and connectivity requirements when mated with dia. .0355-.0365 male pin.

For more information, please contact customer service at (507) 833-8822 or (800) 247-8256 • cinch.com

Illustrations are shown in inches (millimeters).

Specifications

Field Replaceable Application Notes

These field replaceable connectors are easy to install and replace. The hermetic seal is mounted into the circuit module wall and the connector can be removed and replaced without destroying the hermeticity of the circuit housing.

The field replaceable connector creates a transition from microstrip circuitry to a coaxial transmission line. The SMK (2.92mm) seal pin diameter is .012 (.030) to minimize the capacitive effects on the circuit trace. For optimum electrical performance, the transition from the hermetic seal to the microstrip trace must be properly compensated which involves adjusting the microstrip trace width to minimize any impedance discontinuities found in the transition area.

The plot shown below is representative of the typical return loss of a Johnson field replaceable SMK connector. To produce the data shown below, a test fixture is created using the Johnson SMK hermetic seal. The fixture consists of a suitably thick spacer plate with the hermetic seal mounted flush to both surfaces. Two connectors are mounted back to back around the fixture and the VSWR of this test assembly is measured. The calculated return loss trace shown is equivalent to the square root of the measured VSWR of the test assembly. Since the connectors tested are of identical design, it can be stated with fair accuracy that the calculated data shown represents the response of a single field replaceable connector and its transition to the hermetic seal.

Although we do not publish a VSWR specification for field replaceable connectors, typical connector return loss can be expected to be better than 20 dB through 40 GHz. A VSWR specification is not stated because an industry standard method for testing field replaceable connectors does not exist. The actual performance of the connector is dependent upon the following:

1. For optimum electrical performance, we recommend the use of our standard 142-1000-033 hermetic seal with a pin diameter of .0120 \pm .0005 (0.305 \pm 0.013).
2. It is recommended that the hermetic seal be mounted flush with the circuit housing. Tolerance variations between the hermetic seal and machined housing do not always guarantee an optimum transition to the connector. Some manufacturers recommend an additional counterbore in the circuit housing to accommodate a solder washer during installation of the seal. We do not recommend this type of installation because, if the counterbore is not completely filled with solder, electrical discontinuities may be created.
3. The transition between the hermetic seal pin and the microstrip trace will effect electrical performance, as stated above. Several different methods of hermetic seal mounting and seal pin to microstrip trace attachment are used in the industry.

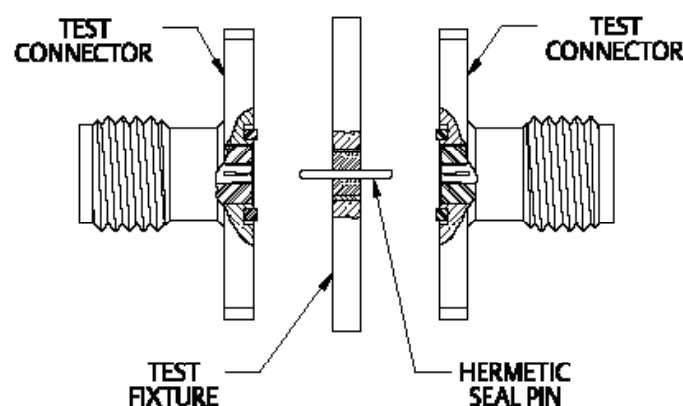

Straight Solder Type Plug – with Contact, Slide-On Nut



Cable Type	Gold Plated	Passivated*
RG-405 RG-402	145-0693-001	145-0693-002
RG-405 RG-402	145-0694-001	145-0694-002

Assembly instructions page 212.

*Passivated coupling nut with gold plated body.

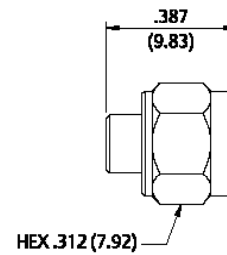

2-Hole Flange Mount Jack Receptacle

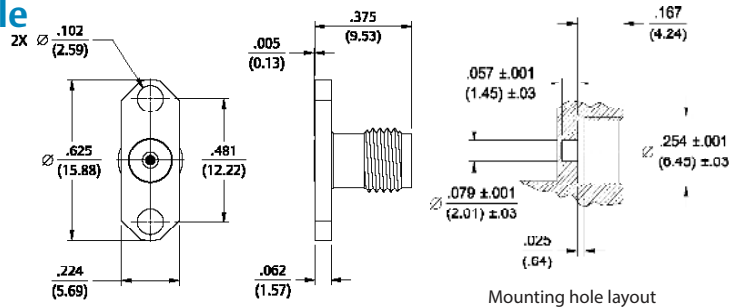

Gold Plated	Passivated	Accepts Pin Size
145-0701-601	145-0701-602	.0120+/- .0005(0.305+/-0.013)

4-Hole Flange Mount Jack Receptacle

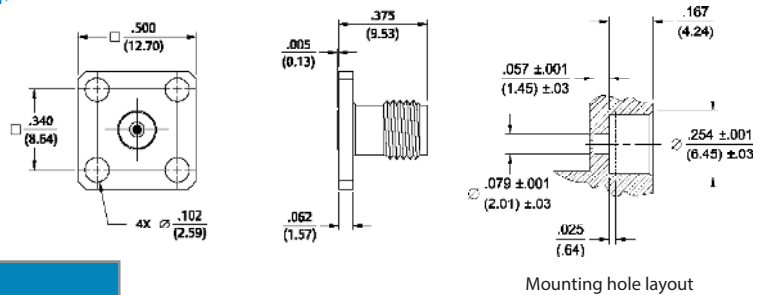

Gold Plated	Passivated	Accepts Pin Size
145-0701-611	145-0701-612	.0120+/- .0005(0.305+/-0.013)

Jack Receptacle – Thread Mount Field Replaceable

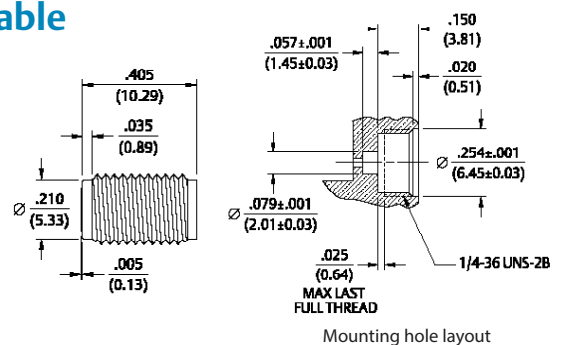

Gold Plated	Passivated	Accepts Pin Size
145-0701-001	145-0701-002	.0120 +/- .0005 (0.305 +/-0.013)

For more information, please contact customer service at (507) 833-8822 or (800) 247-8256 • cinch.com

Illustrations are shown in inches (millimeters).

In-Series Adapters

Hermetic Seal Feedthru

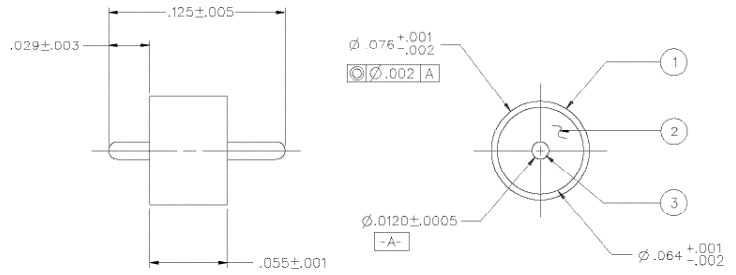

Part No.	Item 1 – Outer Ring	Item 2 – Insulator	Item 3 – Pin
142-1000-033	Kovar Gold Pl .00005 min over Nickel Pl .00005 min	Glass Corning 7070 Or Equivalent	Kovar Gold Pl .00005 min. over Nickel Pl .00005 min.

Notes:

- The hermetic seal should be mounted as flush as possible with the housing. Excessive recession will create a high impedance air gap between connection and housing which degrades electrical performance.
- The use of an additional counterbore to accommodate a solder ring for seal mounting is not recommended. A slight chamfer may be used if care is taken to completely fill the area with solder. **Avoid air gaps!**

Electrical

Impedance: 50 Ohms
Frequency Range: DC to 40 GHz
VSWR: Dependent upon application
Working Voltage: 250 VRMS max at sea level
Dielectric Withstanding Voltage: 500 VRMS min at sea level
Insulation Resistance: 5000 Megohm min
Insertion Loss: 0.2 dB max at 40 GHz

Environmental

Hermeticity: 1x10-8 cc/sec at one atmosphere
Solderability: MIL-STD-202, Method 209
Operating Temperature: -55° C to +165° C

Jack to Jack In-Series Adapter



Gold Plated
 145-0901-801

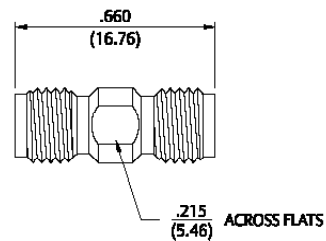

Plug to Plug In-Series Adapter



Gold Plated
 145-0901-811

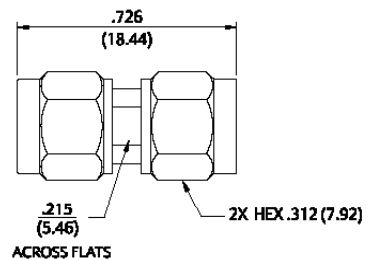

Plug to Jack In-Series Adapter



Gold Plated
 145-0901-821

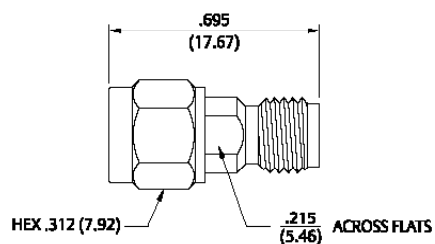

SMA Connectors

50 Ohm Connectors	
Specifications.....	46
Quick Connect.....	49
Semi-Rigid & Flexible Cable	50
PC Mount.....	56
Bulkhead & Panel Mount.....	62
Self-Fixture End Launch.....	63
Field Replaceable	71
Adapters	76
Terminations	77
Reverse Polarity	
Specifications.....	78
Semi-Rigid & Flexible Cable	80
PC Mount.....	81
Reverse Thread	
Specifications.....	82
Semi-Rigid & Flexible Cable	83
PC Mount.....	85
50 Ohm Non-Magnetic Connectors	
Specifications.....	86
Semi-Rigid & Flexible Cable	87
PC Mount.....	88
50 Ohm High Frequency End Launch	
Specifications.....	90
PC Mount.....	92
50 Ohm Stainless Steel	
Specifications.....	94
Semi-Rigid & Flexible Cable	97
PC Mount.....	100
Bulkhead & Panel Mount.....	100
Fixed Attenuators	
Specifications.....	102
Attenuators.....	113
Other Information	
Assembly Tools	185
Capabilities	190
Cable Information	192
Assembly Instruction.....	193
Mounting Hole Layouts	194
Numerical Index	274
Competitor Cross Reference	280

3	MMCX Connectors
13	MCX Connectors
39	SMK Connectors
45	SMA Connectors
103	SMB Connectors
131	SMC Connectors
137	SMP Connectors
145	Type N Connectors
153	Shielded Cable Terminations
157	Between-Series Adapters
161	Fixed Length Cable Assemblies
173	Ultra Miniature Connectors (UMC)
181	kwiQMate™ Connectors
185	Tools
193	Assembly Instructions
257	Electronic Hardware
274	Index

While every precaution has been taken to ensure accuracy and completeness herein, Cinch Connectivity Solutions assumes no responsibility, and disclaims all liability for damages resulting from use of this information or for any errors or omissions. Specifications subject to change without notice.

Specifications

Electrical Ratings

Impedance: 50 Ohms

Frequency Range:

Dummy loads.....	0-2.00 GHz
Flexible cabled connectors.....	0-12.4 GHz
Uncabled receptacles, Right Angle Semi-Rigid cabled connectors and adapters.....	0-18.0 GHz
Straight Semi-Rigid cabled connectors and field replaceable connectors	0-26.5 GHz

VSWR: (max) (f = GHz)

	Straight Cabled Connectors	Right Angle Cabled Connectors
RG-178.....	1.20 + .025f	1.20 + .03f
RG-316, LMR-100.....	1.15 + .02f	1.15 + .03f
RG-58, LMR-195.....	1.15 + .01f	1.15 + .02f
RG-142.....	1.15 + .01f	1.15 + .02f
LMR-200, LMR-240.....	1.10 + .03f	1.10 + .06f
RG-405.....	1.07 + .008f	1.18 + .015f
RG-402 (w/contact).....	1.05 + .008f	1.15 + .015f
RG-402 (w/o contact).....	1.035 + .005f	
Jack-bulkhead jack adapter and plug-plug adapter.....		1.05 + .010f
Jack-jack adapter and plug-jack adapter.....		1.05 + .005f
Uncabled receptacles, dummy loads.....		N/A
Field replaceable (see page 80).....		N/A

Working Voltage: (VRMS max)†

	Sea Level	70K Feet
RG-178.....	170	45
RG-316, LMR-100, 195, 200.....	250	65
RG-58, RG-142, LMR-240, RG-405, uncabled receptacles, RG-402 w/o contact.....	335	85
RG-402 with contact and adapters.....	500	125
Dummy loads.....		N/A

Dielectric Withstanding Voltage: (VRMS min at sea level)†

RG-178.....	500
RG-316, LMR-100, 195, 200.....	750
RG-58, RG-142, LMR-240, RG-405, field replaceable, uncabled receptacles.....	1000
RG-402 with contact and adapters.....	1500
RG-402 w/o contact, dummy loads.....	N/A

Insulation Resistance: 5000 megohms min

Contact Resistance: (milliohms max)

	Initial	After Environmental
Center contact (straight cabled connectors and uncabled receptacles).....	3.0*	4.0*
Center contact (right angle cabled connectors and adapters).....	4.0	6.0
Field replaceable connectors.....	6.0	8.0
Outer contact (all connectors).....	2.0	N/A
Braid to body (gold plated connectors).....	0.5	N/A
Braid to body (nickel plated connectors).....	5.0	N/A

*N/A where the cable center conductor is used as a contact

Corona Level: (Volts min at 70,000 feet)†

RG-178.....	125
RG-316, LMR-100, 195, 200.....	190
RG-58, RG-142, LMR-240, RG-405, uncabled receptacles, RG-402 w/o contact.....	250
RG-402 with contact and adapters.....	375
Dummy loads.....	N/A

Insertion Loss: (dB max)

Straight flexible cable connectors and adapters.....	0.06 \sqrt{f} (GHz),	tested at 6 GHz
Right angle flexible cable connectors.....	0.15 \sqrt{f} (GHz),	tested at 6 GHz
Straight Semi-Rigid cable connectors with contact	0.03 \sqrt{f} (GHz),	tested at 10 GHz
Right angle Semi-Rigid cable connectors	0.05 \sqrt{f} (GHz),	tested at 10 GHz
Straight Semi-Rigid cable connectors w/o contact	0.03 \sqrt{f} (GHz),	tested at 16 GHz
Straight low loss flexible cable connectors	0.06 \sqrt{f} (GHz),	tested at 1 GHz
Right Angle low loss flexible cable connectors	0.15 \sqrt{f} (GHz),	tested at 1 GHz
Uncabled receptacles, field replaceable, dummy loads	N/A	

RF Leakage: (dB min, tested at 2.5 GHz)

Flexible cable connectors, adapters and RG-402 connectors w/o contact.....	-60 dB
Field replaceable w/o EMI gasket.....	-70 dB
RG-405 connectors and RG-402 connectors with contact, and field replaceable with EMI Gasket	-90 dB
Two-way adapters	-90 dB
Uncabled receptacles, dummy loads.....	N/A

RF High Potential Withstanding Voltage:

(VRMS min, tested at 4 and 7 MHz)†

RG-178.....	335
RG-316, LMR-100, 195, 200	500
RG-58, RG-142, LMR-240, RG-405, RG-402 connectors w/o contact, uncabled receptacles.....	670
RG-402 with contact and adapters.....	1000

Power Rating (Dummy Load): 0.5 watt @ + 25°C, derated to 0.25 watt @ +125°C

Mechanical Ratings

Engagement Design:	MIL-STD-348, Series SMA
Engagement/Disengagement Force:	2 lb-in max
Mating Torque:	7 to 10 lb-in
Bulkhead Mounting Nut Torque:	15 lb-in
Coupling Proof Torque:	15 lb-in min
Coupling Nut Retention:	60 lbs min
Contact Retention:	6 lbs min axial force (captivated contacts) 4 oz-in min torque (uncabled receptacles)

Cable Retention:	Axial Force* (lbs)	Torque (oz-in)
RG-178.....	10	N/A
RG-316, LMR-100	20	N/A
LMR-195, 200.....	30	N/A
RG-58, LMR-240.....	40	N/A
RG-142.....	45	N/A
RG-405.....	30	16
RG-402.....	60	55

*Or cable breaking strength whichever is less.

Durability: 500 cycles min 100 cycles min for RG-402 connectors w/o contact

Environmental Specifications

(Meets or Exceeds the Applicable Paragraph of MIL-PRF-39012)

Temperature Range:	- 65°C to + 165°C
Thermal Shock:	MIL-STD-202, Method 107, Condition B (N/A dummy loads)
Corrosion:	MIL-STD-202, Method 101, Condition B (N/A dummy loads)
Shock:	MIL-STD-202, Method 213, Condition I (N/A dummy loads)
Vibration:	MIL-STD-202, Method 204, Condition Dv
Moisture Resistance:	MIL-STD-202, Method 106 (N/A dummy loads)

† Avoid user injury due to misapplication. See safety advisory definitions.

For more information, please contact customer service at (507) 833-8822 or (800) 247-8256 • cinch.com

Illustrations are shown in inches (millimeters).

Specifications

Material Specifications

Bodies:	Brass per ASTM B16, gold plated* per MIL-DTL-45204 .00001" min. or nickel plated per SAE-AMS2423
Contacts:	Male - brass per ASTM B16, gold plated per MIL-DTL-45204 .00005" min Female - beryllium copper per ASTM B196, gold plated per MIL-DTL-45204 .00005" min
Nut Retention Spring:	Beryllium copper per ASTM B196, Unplated
Insulators:	PTFE fluorocarbon per ASTM D 1710 and ASTM D 1457 or Tefzel per ASTM D 3159 or PFA 340 per ASTM D 3307
Expansion Caps:	Brass per ASTM B36, gold plated per MIL-DTL-45204 .00001" min. or nickel plated per SAE-AMS2423
Crimp Sleeves:	Copper per ASTM B301 or brass per ASTM B16, gold plated per MIL-DTL-45204 .00001" min or nickel plated per SAE-AMS2423
Mounting Hardware:	Brass (nuts) per ASTM B16 or phosphor bronze (lockwashers), gold plated per MIL-DTL-45204 .00005" min or nickel plated per SAE-AMS2423
Seal Rings:	Silicone rubber per A-A-59588A
EMI Gaskets:	Conductive silicone rubber per MIL-G-83528, Type M

* All gold plated parts include a .00005" min. nickel underplate barrier layer

Mating Engagement for SMA Series

NOTES

1. ID to meet VSWR, contact resistance and insertion withdrawal forces when mated with a die. XES5-8370 pin.
2. Gasket is not supplied with base connectors.

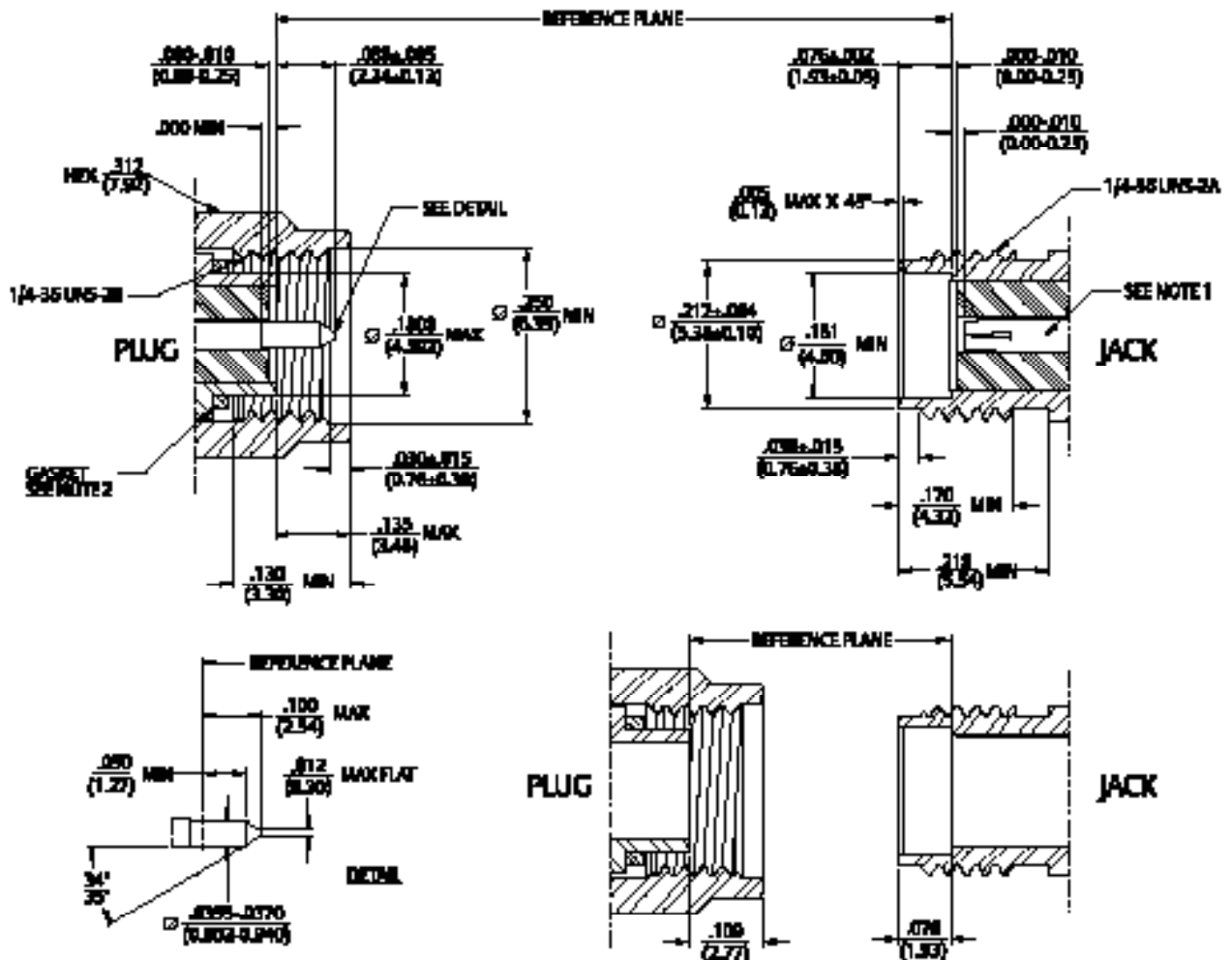

The Johnson line of **SMA Quick-Connect Plug** quickly mates to a standard, threaded SMA Jack receptacle allowing rapid test connections to devices utilizing SMA threaded jacks.

SMA electrical performance is not compromised because the connector retains all the benefits of a threaded coaxial coupling. The final connection is a solid metal to metal coupling not relying on spring forces to maintain the coupling. This results in a more reliable connection with less signal leakage and a lower VSWR than most push-on connectors.

Full MIL-PRF-39012 electrical compatibility is obtained with a push and twist motion. The knurled thumbnut requires only one half to one full turn to create a solid electromechanical connection. Rapid disconnect is accomplished with a twist and pull motion.

The SMA Quick-Connect Plug Adapter converts a standard SMA Plug test cable into a Quick-Connect cable. This makes the testing process more efficient by reducing the time and effort required to connect and disconnect the test cable.

Note: Push-on using front of connector, twist back-end coupling nut to secure.

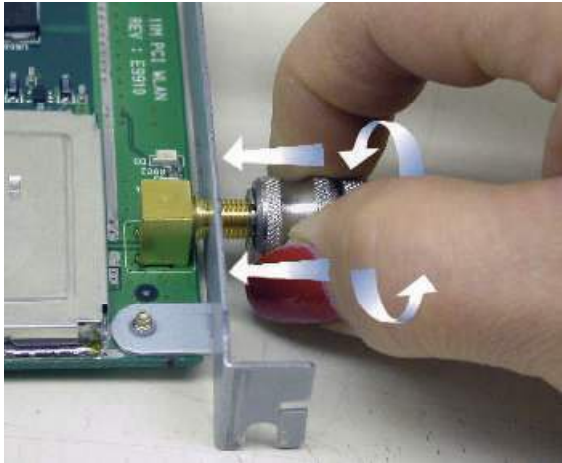

Plugs		
Cable Type	Gold Plated*	"A"
RG-161, 174, 188, 316	142-1403-001	1.249
RG-188 DS, RG-316 DS	142-1404-001	1.249
RG-58, 141, 303	142-1407-001	1.099
RG-55, 142, 223, 400	142-1408-001	1.249

Adapters	
Gold Plated*	
142-1901-821	

*Nickel plated coupling hardware, gold plated body
 Assembly instructions page 219.

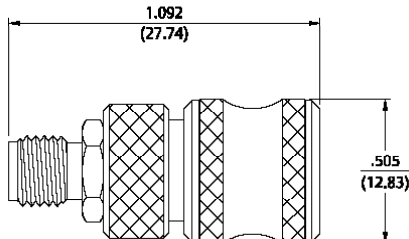
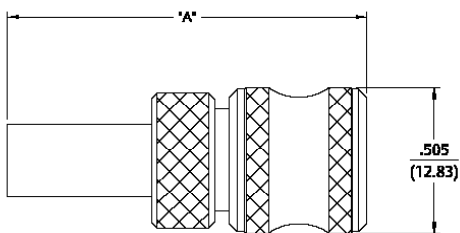

For more information, please contact customer service at (507) 833-8822 or (800) 247-8256 • cinch.com
 Illustrations are shown in inches (millimeters).

Semi-Rigid Cable

Straight Solder Type Plug – with Contact, Captive Nut Thin Wall Connector Interface



Cable Type	Gold Plated	Nickel Plated	Fig.	"A"
RG-405	142-0693-001	142-0693-006	1	.405 (10.29)
RG-402	142-0694-001*	142-0694-006*	2	.440 (11.18)

Assembly instructions page 214.

*Mating torque 8 lb-in max, coupling proof torque 8 lb-in max.

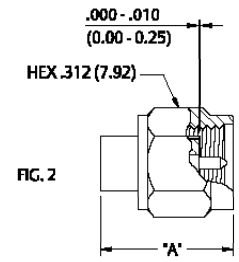
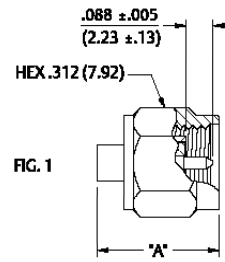

Straight Solder Type Plug – without Contact, Thread-on Nut



Cable Type	Gold Plated	Nickel Plated
RG-402	142-0694-011	142-0694-016

Assembly instructions page 214.

Center conductor of cable serves as contact.

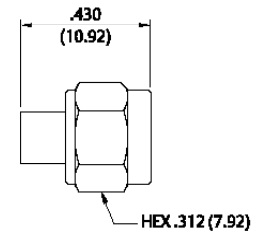

Right Angle Solder Type Plug (1-piece body)



Cable Type	Gold Plated	Nickel Plated	"A"	"B"
RG-405	142-0693-101	142-0693-106	.336 (8.53)	.253 (6.43)
RG-402	142-0694-101	142-0694-106	.462 (11.73)	.306 (7.77)

Assembly instructions page 213.

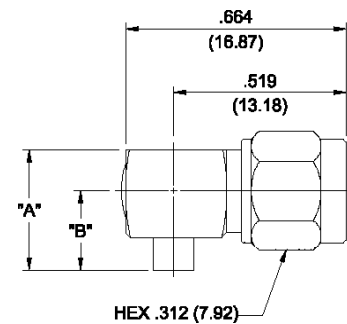

Straight Solder Type Plug – with Contact, Thread-on Nut

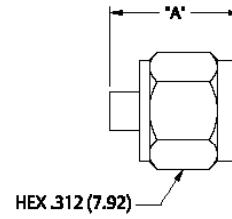

Cable Type	Gold Plated	Nickel Plated	"A"
RG-405	142-0693-051	142-0693-056	.405 (10.29)
RG-402	142-0694-051	142-0694-056	.438 (11.13)

Assembly instructions page 216.

Straight Solder Type Plug – Short Profile – without Contact, Captive Nut

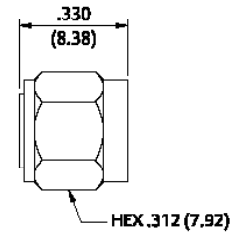

Cable Type	Gold Plated	Nickel Plated
RG-402	142-0694-031	142-0694-036

Assembly instructions page 215. Center conductor of cable serves as contact.

Straight Solder Type Plug – without Contact, Slide-on Nut

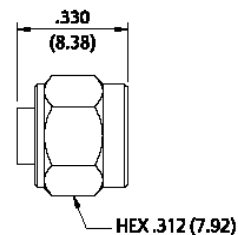

Cable Type	Gold Plated	Nickel Plated
RG-402	142-0694-021	142-0694-026

Assembly instructions page 215.
Center conductor of cable serves as contact.

Straight Solder Type Plug – without Contact, Slide-on Notched Nut

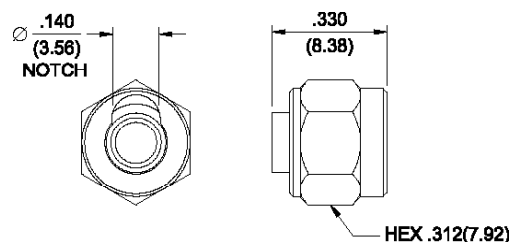

Cable Type	Gold Plated	Nickel Plated
RG-402	142-0694-041	142-0694-046

Assembly instructions page 215. Center conductor of cable serves as contact.

For more information, please contact customer service at (507) 833-8822 or (800) 247-8256 • cinch.com

Illustrations are shown in inches (millimeters).

Semi-Rigid Cable

Straight Solder Type Jack

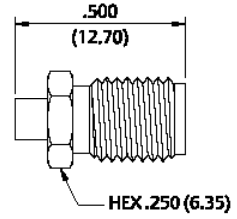

Cable Type	Gold Plated	Nickel Plated
RG-405	142-0593-001	142-0593-006
RG-402	142-0594-001	142-0594-006

Assembly instructions page 214.

Straight Solder Type Bulkhead Jack with O-Ring

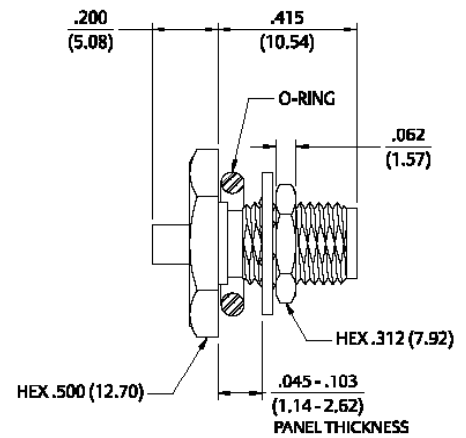

Cable Type	Gold Plated	Nickel Plated
RG-405	142-0593-401	142-0593-406
RG-402	142-0594-401	142-0594-406

Assembly instructions page 214.
Mounting hole layout figure 1 page 194.

Straight Solder Type Bulkhead Jack

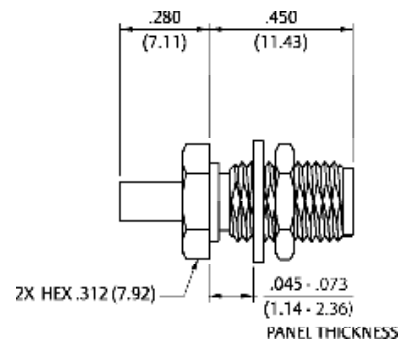

Cable Type	Gold Plated
RG-405	142-0593-411

Assembly instructions page 214.
Mounting hole layout figure 1 page 194.

Straight Crimp Type Plug (3-piece) – Solder or Crimp Captivated Contact

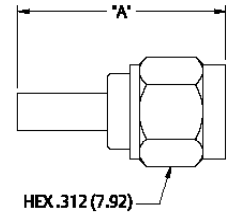

Cable Type	Gold Plated	Nickel Plated	"A"
RG-178, 196	142-0402-011	142-0402-016	.591 (15.01)
RG-161, 174,188, 316, LMR-100 HPF-100 RF-100	142-0403-011	142-0403-016	.706 (17.93)
RG-188 DS, RG-316 DS	142-0404-011	142-0404-016	.706 (17.93)
RG-58, 141, 303, LMR-195, HPF-195, RF-195	142-0407-011	142-0407-016	.706 (17.93)
RG-55, 142, 223, 400	142-0408-011	142-0408-016	.706 (17.93)
RG-179, 187	142-0433-011	142-0433-016	.706 (17.93)
LMR-200, HPF-200, RF-200	142-0439-001	142-0439-006	.844 (21.44)
LMR-240, HPF-240, RF-240	142-0435-001	142-0435-006	.844 (21.44)

Assembly Instructions: RG-178 page 217. LMR 195, 200 and 240, see page 220.
Other cable groups, see page 219.

Right Angle Crimp Type Plug – Captivated Contact

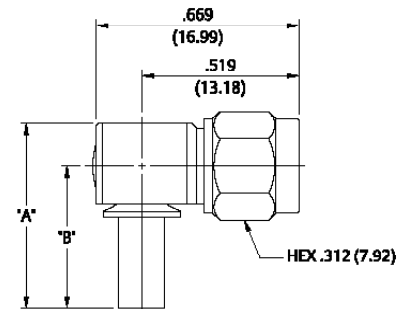

Cable Type	Gold Plated	Nickel Plated	"A"	"B"
RG-178, 196	142-0402-101	142-0402-106	.611 (15.52)	.470 (11.94)
R-161, 174,188, 316, LMR-100, HPF-100, RF-100	142-0403-101	142-0403-106	.611 (15.52)	.470 (11.94)
RG-188 DS, RG-316 DS	142-0404-101	142-0404-106	.611 (15.52)	.470 (11.94)
LMR-195, HPF-195, RF-195, RG-58, 141, 303	142-0407-101	142-0407-106	.611 (15.52)	.470 (11.94)
RG-55, 142, 223, 400	142-0408-101	142-0408-106	.611 (15.52)	.470 (11.94)
RG-179, 187	142-0433-101	142-0433-106	.611 (15.52)	.470 (11.94)
LMR-200, HPF-200, RF-200	142-0439-101	142-0439-106	.611 (15.52)	.470 (11.94)
LMR-240, HPF-240, RF-240	142-0435-101	142-0435-106	.635 (16.13)	.490 (12.45)

Assembly Instructions: LMR 195, 200 and 240 page 229.
Other cable groups, see page 224.

For more information, please contact customer service at (507) 833-8822 or (800) 247-8256 • cinch.com

Illustrations are shown in inches (millimeters).

Flexible Cable

Straight Crimp Type Bulkhead Jack – Captivated Contact



Cable Type	Gold Plated	Nickel Plated
RG-178, 196	142-0302-401	142-0302-406
RG-161, 174,188, 316	142-0303-401	142-0303-406
RG-188 DS, RG-316 DS	142-0304-401	142-0304-406
RG-58, 141, 303	142-0307-401	142-0307-406
RG-55, 142, 223, 400	142-0308-401	142-0308-406

Assembly instructions page 225.
Mounting hole layout figure 1 page 194.

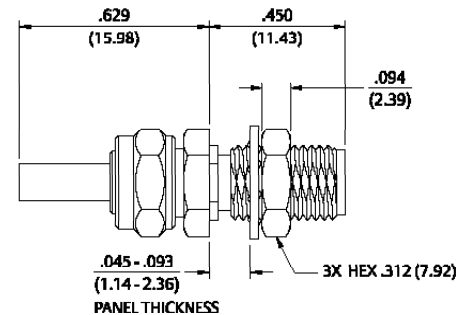

Straight Crimp Type Bulkhead Jack (3-piece) – Solder or Crimp Captivated Contact



Cable Type	Gold Plated	Nickel Plated	"A"
RG-178, 196	142-0302-431	142-0302-436	.285 (7.24)
RG-161, RG-16, 174,188, 316, LMR-100 HPF-100 RF-100	142-0303-411	142-0303-416	.385 (9.78)
RG-188 DS, RG-316 DS	142-0304-411	142-0304-416	.385 (9.78)
RG-58, 141, 303, LMR-195, HPF-195, RF-195	142-0307-411	142-0307-416	.385(9.78)
RG-55, 142, 223, 400	142-0308-411	142-0308-416	.385 (9.78)
RG-179, 187	142-0333-411	142-0333-416	.385 (9.78)
LMR-200, HPF-200, RF-200	142-0339-401	142-0339-406	.545 (13.84)
LMR-240, HPF-240, RF-240	142-0335-401	142-0335-406	.545 (13.84)

Assembly Instructions: RG-178 page 217. LMR 195, 200 and 240, see page 220.
Other cable groups, see page 219. Mounting hole layout figure 1 page 194.

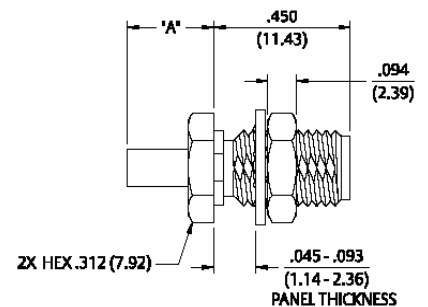

Straight Crimp Type Jack (3-piece) – Solder or Crimp Captivated Contact



Cable Type	Gold Plated	Nickel Plated	"A"
RG-178, 196	142-0302-011	142-0302-016	.651 (16.54)
RG-161, 174,188, 316	142-0303-011	142-0303-016	.756 (19.20)
RG-188 DS, RG-316 DS	142-0304-011	142-0304-016	.756 (19.20)
RG-58, 141, 303	142-0307-011	142-0307-016	.756 (19.20)
RG-55, 142, 223, 400	142-0308-011	142-0308-016	.756 (19.20)

Assembly Instructions: RG-178 page 217. LMR 195, 200 and 240, see page 220.
Other cable groups, see page 219. Mounting hole layout figure 1 page 194.

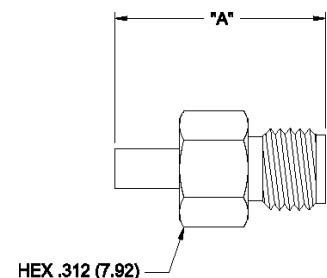

Straight Clamp Type Plug – Captivated Contact

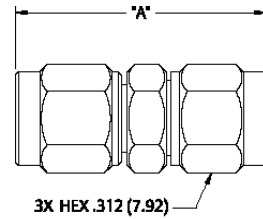

Cable Type	Gold Plated	Nickel Plated	"A"
RG-178, 196	142-0202-011	142-0202-016	.816 (20.73)
RG-161, 174, 188, 316	142-0203-011	142-0203-016	.816 (20.73)
RG-58, 141, 303, 55, 142, 223, 400	142-0207-011	142-0207-016	.895 (22.73)

Assembly instructions page 230.
Mounting hole layout figure 1 page 194.

Right Angle Clamp Type Plug – Captivated Contact

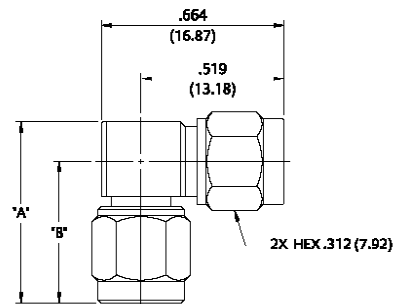

Cable Type	Gold Plated	Nickel Plated	"A"	"B"
RG-178 196	142-0202-101	142-0202-106	.569 (14.45)	.428 (10.81)
RG-161 174, 188, 316	142-0203-101	142-0203-106	.574 (14.58)	.433 (11.00)
RG-58, 141, 303, 55, 142, 223, 400	142-0207-101	142-0207-106	.686 (17.42)	.545 (13.84)

Assembly instructions page 231.
Mounting hole layout figure 1 page 194.

Straight Clamp Type Bulkhead Jack – Captivated Contact

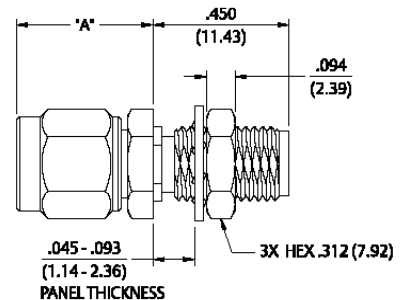

Cable Type	Gold Plated	Nickel Plated	"A"
RG-178, 196	142-0102-401	142-0102-406	.452 (11.48)
RG-161, 174, 188, 316	142-0103-401	142-0103-406	.487 (12.37)
RG-58, 141, 303, 55, 142, 223, 400	142-0107-401	142-0107-406	.531 (13.49)

Assembly instructions page 230.

Rear Mount Bulkhead Plug – Antenna Connector

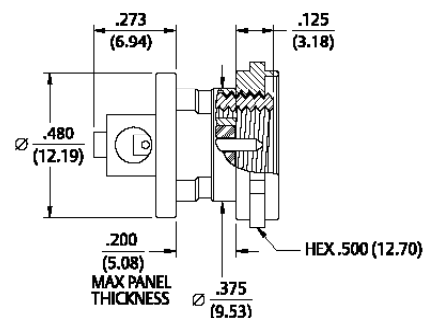

Cable Type	Gold Plated
RG-178, .047 Semi-Rigid	142-0801-421*

* With Nickel mounting nut. Assembly instructions page 216.
Mates with SMA Jack Antenna Interface.

For more information, please contact customer service at (507) 833-8822 or (800) 247-8256 • cinch.com
Illustrations are shown in inches (millimeters).

PC Mount

Straight Plug Receptacle



Gold Plated	Nickel Plated
142-0801-201	142-0801-206

Mounting hole layout figure 2 page 194.

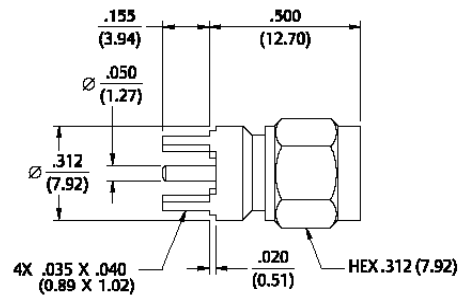

Right Angle Plug Receptacle



Gold Plated	Nickel Plated
142-0801-301	142-0801-306

Mounting hole layout figure 2 page 194.

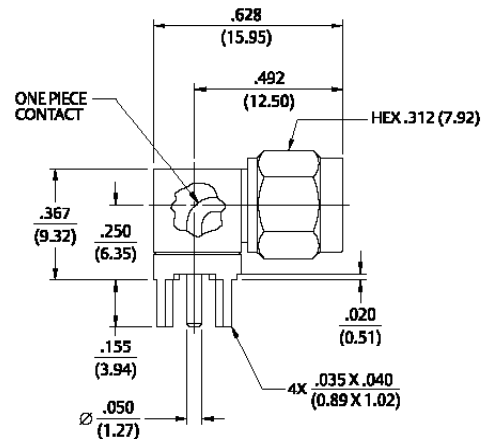

Straight Jack Receptacle



Gold Plated	Nickel Plated	"A"
142-0701-201	142-0701-206	.155 (3.94)
142-0701-231	142-0701-236	.110 (2.79)

Mounting hole layout figure 2 page 194.

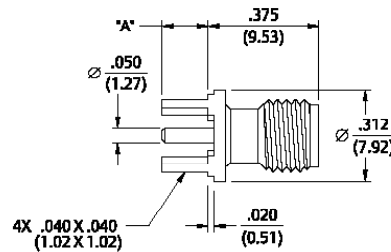

Straight Bulkhead Jack Receptacle



Gold Plated	Nickel Plated	"A"	"B"
142-0701-421	142-0701-426	.700 (17.78)	.450 (11.43)
142-0701-491	142-0701-496	.065 (1.65)	.755 (19.18)

Mounting hole layout figure 2 page 194.

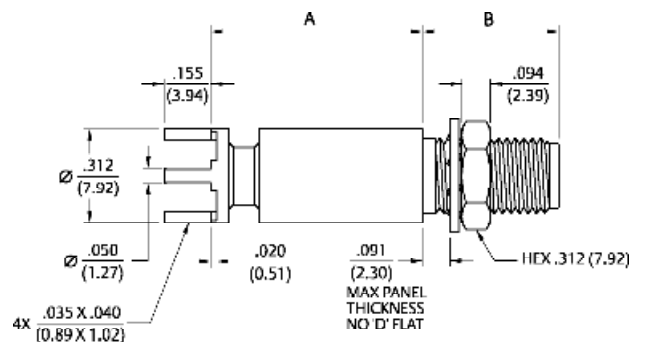

Straight Jack Receptacle – Surface Mount



Gold Plated	Packaging
142-0711-201	Stock
142-0711-202	Tape and Reel 500 pcs/reel

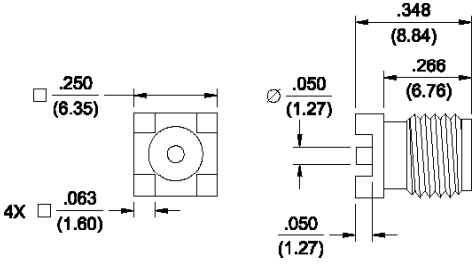

Right Angle Jack Receptacle



Gold Plated	Nickel Plated
142-0701-301	142-0701-306

Recommended Land Pattern figure 2 page 194.

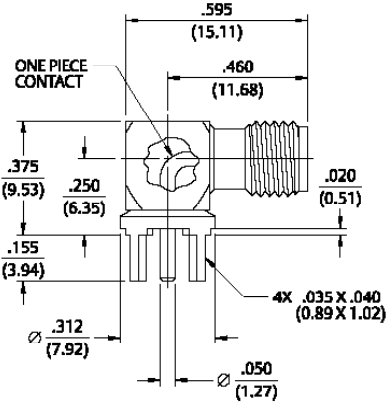

Right Angle Jack Receptacle – Surface Mount



Gold Plated	Packaging
142-0711-301	Stock
142-0711-302	Tape and Reel 425 pcs/reel

Recommended Land Pattern figure 7 page 194.

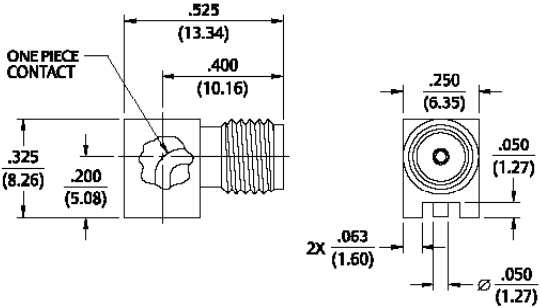

Right Angle Bulkhead Jack Receptacle



Gold Plated	Nickel Plated	"A"
142-0701-501	142-0701-506	.155 (3.94)
142-0701-551	142-0701-556	.110 (2.79)

Mounting hole layout figure 1 and 2 page 194.

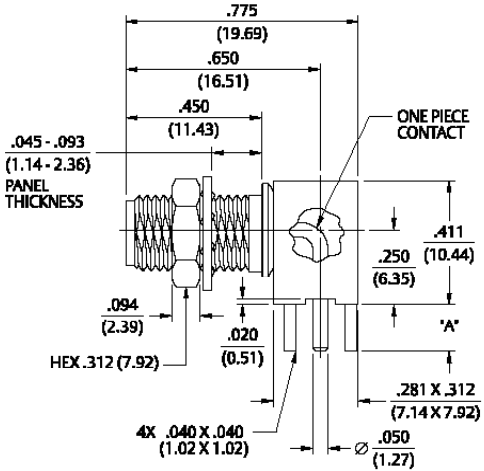

For more information, please contact customer service at (507) 833-8822 or (800) 247-8256 • cinch.com
Illustrations are shown in inches (millimeters).

PC Mount

The **End Launch** connector is attached to the circuit board by inserting the board edge between the legs and soldering the legs and center conductor to pads on the board. For optimum high frequency performance, the connector to circuit board transition must be adjusted for low VSWR. To compensate for the transition from coax to microstrip, trace widths "A" and "B" must be adjusted based on circuit board thickness. When properly adjusted, this technique yields a low VSWR over a wide bandwidth.

The tabulated dimensions "A", "B", "C", "D", and "E" were determined experimentally to achieve low VSWR (typically less than 1.5 up to 18 GHz). The circuit board used connectors for these tests was double-sided FR 4 with 1 oz. copper on both sides. The copper was left on the bottom of the board to create a ground plane for the 50 Ohm microstrip structure. While not all inclusive, these dimensions are given as reference information for selected SMA End Launch connectors. Further adjustments may be necessary depending upon the application. All dimensions are in inches.

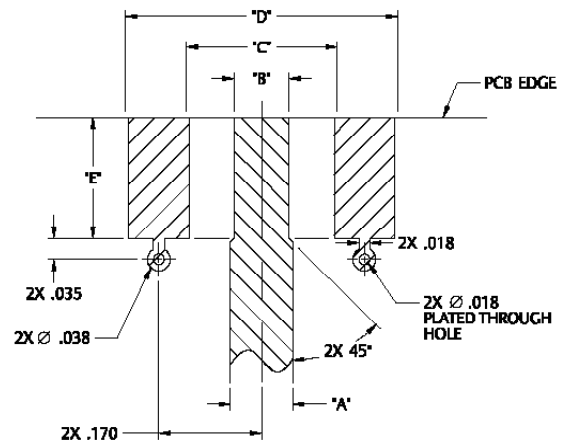

Part No.	Base Width	Board Thickness	"A"	"B"	"C"	"D"	"E"
142-0701-801/806	.375	.062	.103	.090	.250	.440	.200
142-0701-851/858	.375	.062	.103	.090	.250	.440	.200
142-0701-871/876	.375	.062	.103	.090	.250	.440	.200
142-0711-821/826	.250	.062	.103	.070	.170	.380	.165
142-0711-871/876	.375	.047	.083	.075	.250	.440	.200
142-0711-881/886	.375	.047	.083	.075	.250	.440	.200
142-0701-881/886	.375	.031	.050	.045	.250	.440	.200

Tabulated Dimensions "A", "B", "C", and "D" are symmetrical about the center line.

End Launch Plug Receptacle – Round Cont

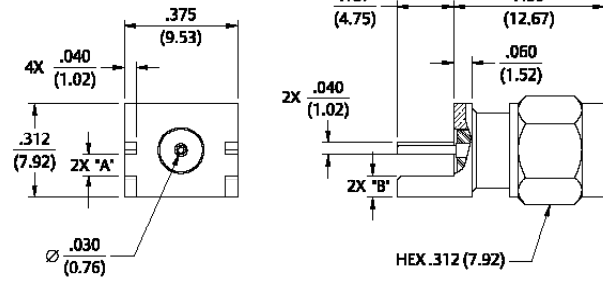

Gold Plated	Nickel Plated	Board Thickness	"A"	"B"
142-0801-801	142-0801-806	.062 (1.57)	.068 (1.73)	.073 (1.85)
142-0801-821	142-0801-826	.042 (1.07)	.048 (1.22)	.093 (2.36)

End Launch Plug Receptacle – Tab Contact

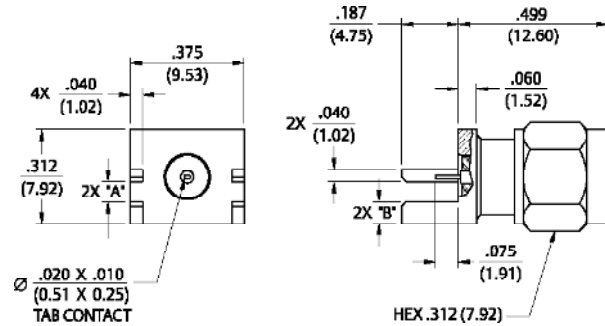

Gold Plated	Nickel Plated	Board Thickness	"A"	"B"
142-0801-811	142-0801-816	.062 (1.57)	.068 (1.73)	.083 (2.11)
142-0801-831	142-0801-836	.042 (1.07)	.048 (1.22)	.103 (2.62)

End Launch Plug Receptacle – Round Contact

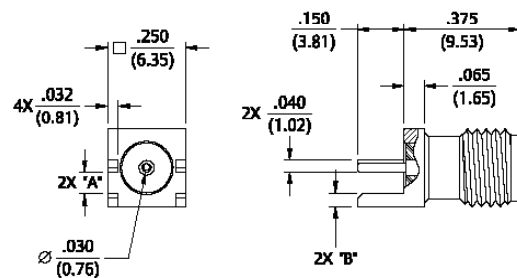

Gold Plated	Nickel Plated	Board Thickness	"A"	"B"
142-0711-821	142-0711-826	.062 (1.57)	.068 (1.73)	.042 (1.07)
142-0711-841	142-0711-846	.042 (1.07)	.048 (1.22)	.062 (1.57)

Coupling proof torque 8 lb-ins maximum without support .083 (2.11) wrench.

For more information, please contact customer service at (507) 833-8822 or (800) 247-8256 • cinch.com

Illustrations are shown in inches (millimeters).

PC Mount

End Launch Jack Receptacle – Round Contact

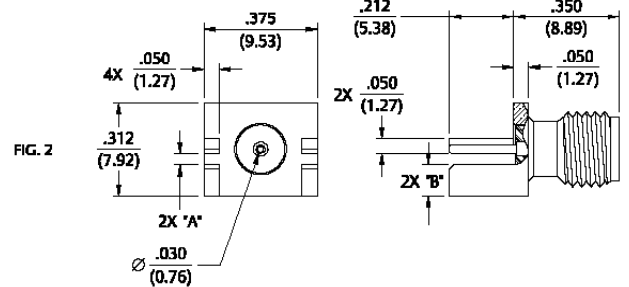
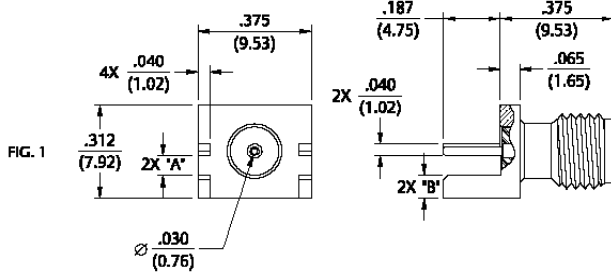

Gold Plated	Nickel Plated	Board Thickness	"A"	"B"	Figure
142-0701-801	142-0701-806	.062 (1.57)	.068 (1.73)	.073 (1.85)	1
142-0701-831	142-0701-836	.042 (1.07)	.048 (1.22)	.093 (2.36)	1
142-0701-881	142-0701-886	.031 (0.79)	.037 (0.94)	.104 (2.64)	2
142-0711-871	142-0711-876	.047 (1.19)	.053 (1.35)	.088 (2.24)	1

End Launch Jack Receptacle – Tab Contact

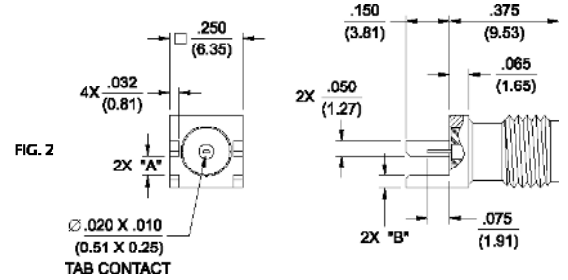
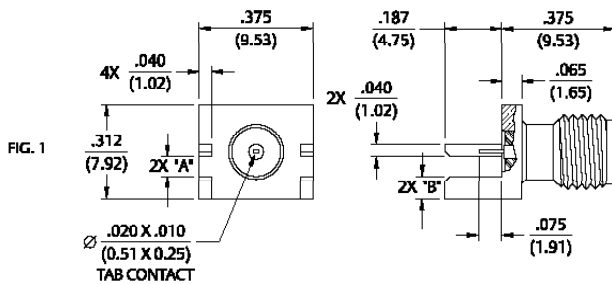

Gold Plated	Nickel Plated	Board Thickness	"A"	"B"	Figure
142-0701-851	142-0701-856	.062 (1.57)	.068 (1.73)	.083 (2.11)	1
142-0701-841	142-0701-846	.042 (1.07)	.048 (1.22)	.103 (2.62)	1
142-0711-881	142-0711-886	.047 (1.19)	.053 (1.35)	.098 (2.24)	1
142-0721-811	142-0721-816	.025 (0.64)	.030 (0.76)	.121 (3.07)	1
142-0721-861	142-0721-866	.032 (0.81)	.037 (0.94)	.083 (2.11)	2

End Launch Bulkhead Jack Receptacle – Round Contact

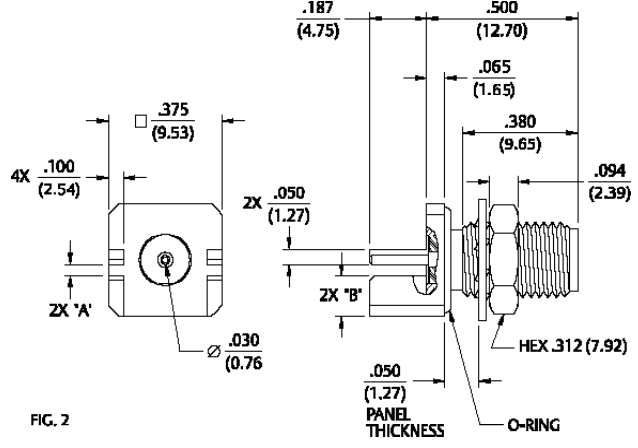
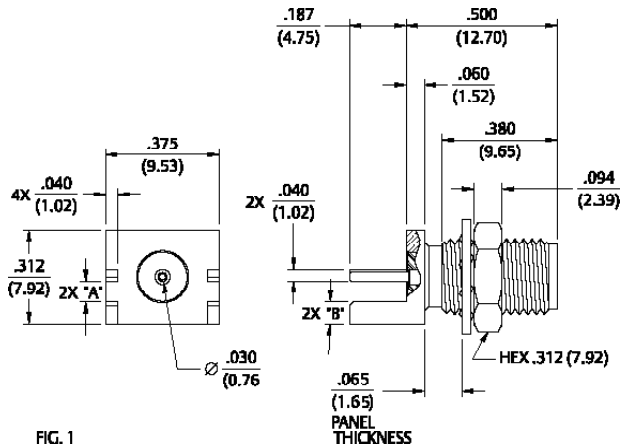

Gold Plated	Nickel Plated	Board Thickness	"A"	"B"	"O" Ring	Figure
142-0701-871	142-0701-876	.062 (1.57)	.068 (1.73)	.073 (1.85)	No	1
142-0721-871	142-0721-876	.074 (1.88)	.080 (2.03)	.061 (1.55)	No	1
142-0721-841	142-0721-846	.069 (1.75)	.075 (1.91)	.066 (1.68)	No	1
142-0731-861	142-0731-866	.031 (0.79)	.037 (0.94)	.135 (3.43)	Yes	2

End Launch Bulkhead Jack Receptacle – Round Contact



Gold Plated	Nickel Plated	Board Thickness
142-0711-811	142-0711-816	.062 (1.57)

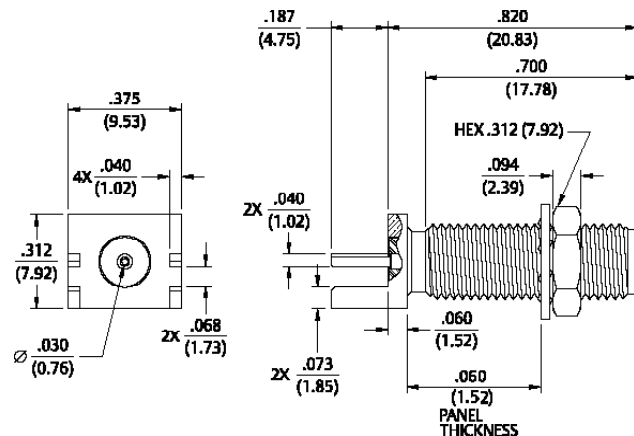

For more information, please contact customer service at (507) 833-8822 or (800) 247-8256 • cinch.com
 Illustrations are shown in inches (millimeters).

Bulkhead Mount

End Launch Jack Receptacle – Surface Mount



Gold Plated	Packaging
142-0721-881	Stock
142-0721-882	Tape and Reel 475 pcs/reel

Recommended land pattern figure 22 page 195.

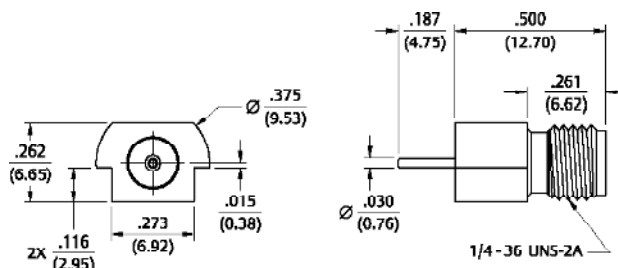

Front Mount Bulkhead Jack Receptacle



Gold Plated	Nickel Plated
142-0701-411	142-0701-416

Mounting hole layout figure 1 page 194.

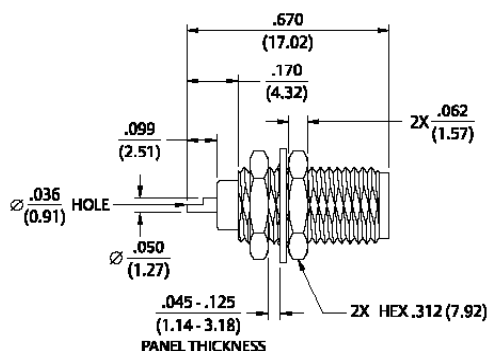

Rear Mount Bulkhead Jack Receptacle



Gold Plated	Nickel Plated
142-0701-401	142-0701-406

Mounting hole layout figure 1 page 194.

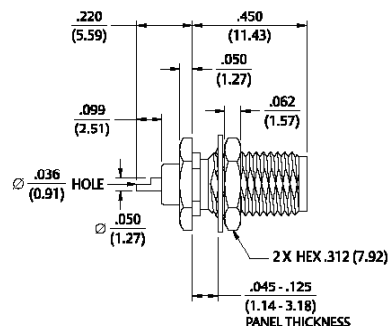

Right Angle Bulkhead Mount Jack Receptacle



Gold Plated	Nickel Plated
142-0701-531	142-0701-536

Mounting hole layout figure 1 page 194.

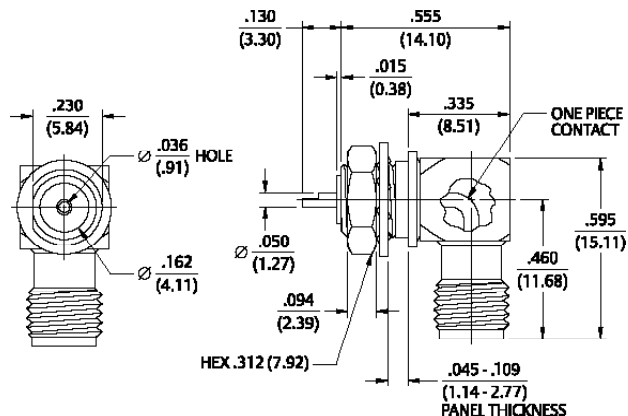

Gold Plated, Round Contact

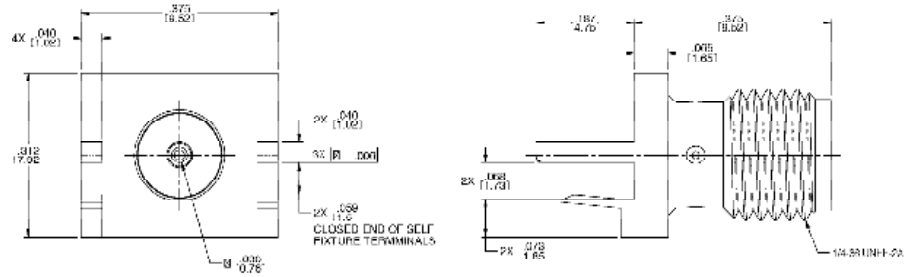
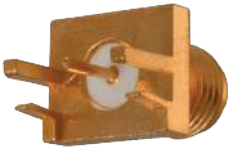

Part No.	Board Thickness
142-0791-801	.062 (1.57)

Assembly instructions page 227.

Gold Plated, Tab Contact

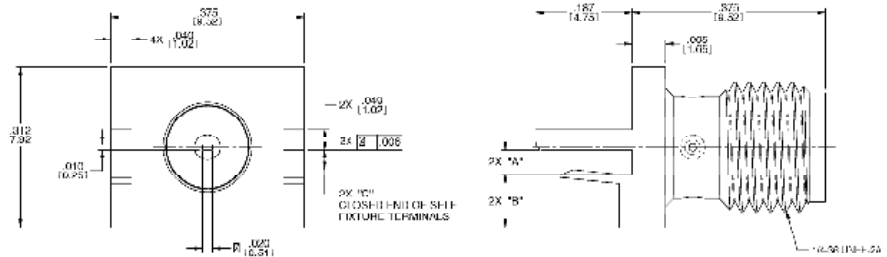
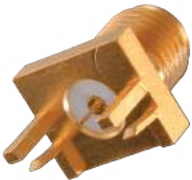

Part No.	Board Thickness	"A"	"B"	"C"
142-0791-811	.042 (1.07)	.048 (1.22)	.103 (2.62)	.039 (0.99)
142-0791-821	.062 (1.57)	.068 (1.73)	.083 (2.11)	.059 (1.50)

Assembly instructions page 227.

Gold Plated, Round Contact – High Frequency

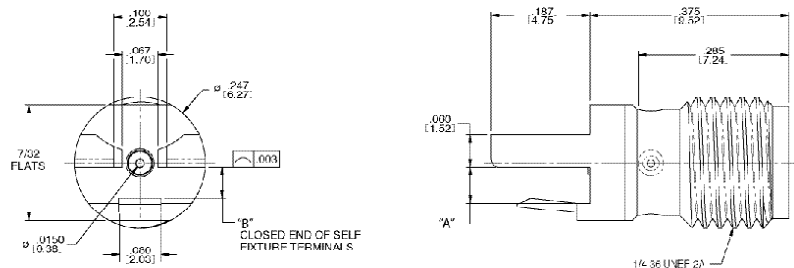

Part No.	Frequency Range	Board Thickness	"A"	"B"
142-1701-821	0-26.5 GHz	.062 (1.57)	.068	.059
142-1701-831	0-26.5 GHz	.059 (1.49)	.063	.054

Assembly instructions page 227.

For more information, please contact customer service at (507) 833-8822 or (800) 247-8256 • cinch.com
Illustrations are shown in inches (millimeters).

Spark Plugs

Jack Receptacle – Thread Mount Field Replaceable



Gold Plated	Nickel Plated	Accepts Pin Size
142-1731-001	142-1731-006	.020 (0.51)
142-1731-011	142-1731-016	.036 (0.91)

Mounting hole layout figure 19 page 195.

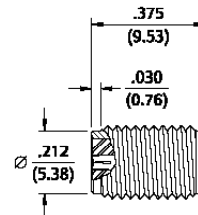

Jack Receptacle – Thread Mount Extended Dielectric (Non-Hermetic)



Gold Plated	Nickel Plated
142-1731-021	142-1731-026

Mounting hole layout for 142-1731-021 figure 19 page 195.
Mounting hole layout for 142-1731-026 figure 18 page 195.

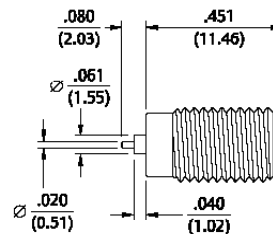

Jack Receptacle – Thread Mount with Hardware Extended Dielectric Bulkhead



Gold Plated	Nickel Plated
142-1731-031	142-1731-036

Mounting hole layout for 142-1731-031 figure 18 page 195.
Mounting hole layout for 142-1731-036 figure 1 page 194.

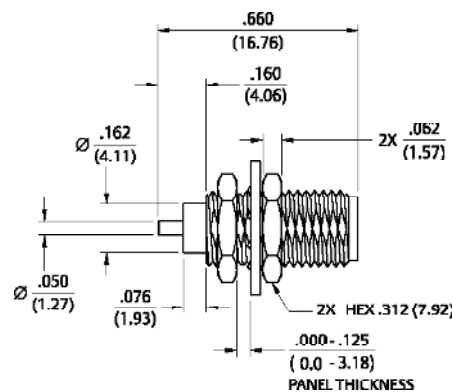

Jack Receptacle – Knurl Mount* Tab Contact



Gold Plated	Nickel Plated
142-1721-001	142-1721-006

* Not intended for use in materials harder than Rockwell B82.
 Assembly tool 140-0000-954 page 188.
 Mounting hole layout figure 17 page 195.

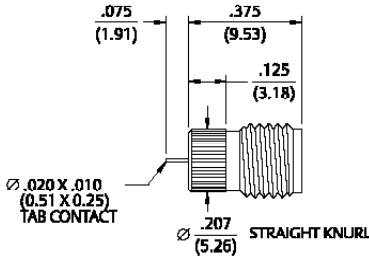

Jack Receptacle – Knurl Mount* Round Contact



Gold Plated	Nickel Plated
142-1721-011	142-1721-016

* Not intended for use in materials harder than Rockwell B82.
 Assembly tool 140-0000-954 page 188.
 Mounting hole layout figure 17 page 195.

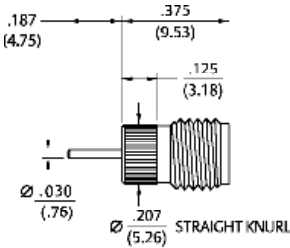

Spark Plugs

Jack Receptacle – Knurl Mount* Round Contact



Gold Plated	Nickel Plated	"A"	"B"
142-1721-011	142-1721-016	.030 (0.76)	.187 (3.18)
142-1721-021	142-1721-026	.050 (1.24)	.190 (4.83)

* Not intended for use in materials harder than Rockwell B82.
Mounting hole layout figure 17 page 195.

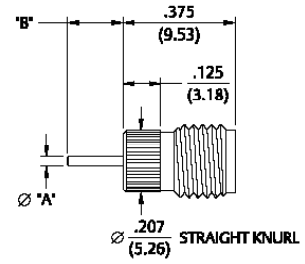

Jack Receptacle – Knurl Mount* Solder Cup Contact



Gold Plated	Nickel Plated
142-0701-481	142-0701-486

* Not intended for use in materials harder than Rockwell B82.
Mounting hole layout figure 17 page 195.

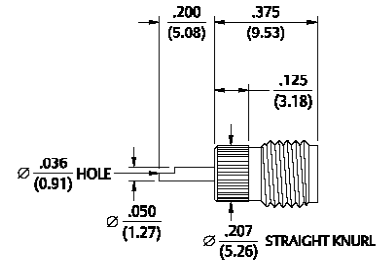

Jack Receptacle – Knurl Mount* Extended Dielectric



Gold Plated	Nickel Plated	"A"	"B"
142-1721-031	142-1721-036	.190 (4.83)	.095 (2.41)
142-1721-041	142-1721-046	.240 (6.10)	.180 (4.57)
142-1721-051	142-1721-056	.705 (17.91)	.590 (14.99)

* Not intended for use in materials harder than Rockwell B82.
Mounting hole layout figure 17 page 195.

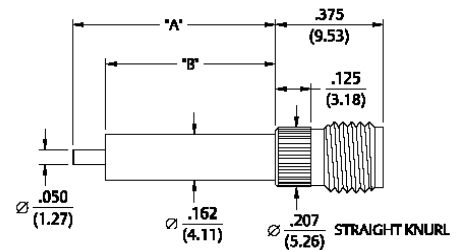

2-Hole Flange Mount Jack Receptacle – Flush Dielectric

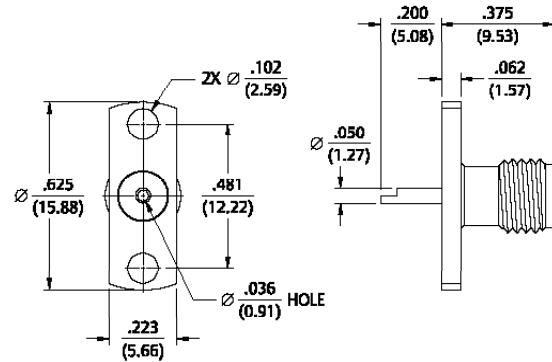

Gold Plated	Nickel Plated
142-0701-621	142-0701-626

4-Hole Flange Mount Jack Receptacle – Flush Dielectric

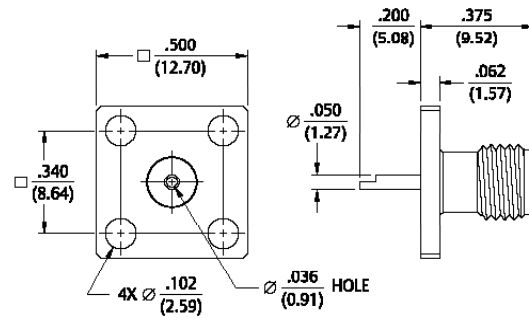

Gold Plated	Nickel Plated
142-0701-631	142-0701-636

2-Hole Flange Mount Jack Receptacle – Extended Dielectric

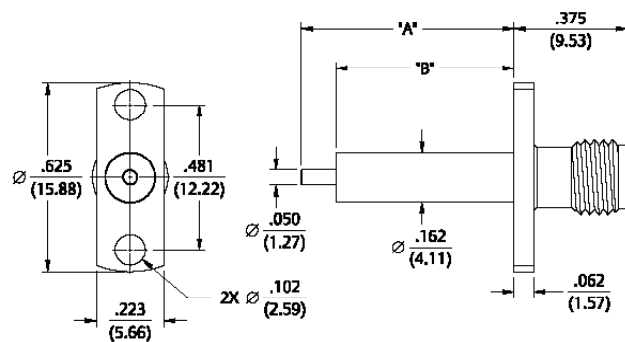

Gold Plated	Nickel Plated	"A"	"B"
142-1701-131	142-1701-136	.705 (17.91)	.590 (14.99)
142-1701-031	142-1701-036	.240 (6.10)	.180 (4.57)

For more information, please contact customer service at (507) 833-8822 or (800) 247-8256 • cinch.com

Illustrations are shown in inches (millimeters).

Panel Mount

4-Hole Flange Mount Jack Receptacle – Extended Dielectric

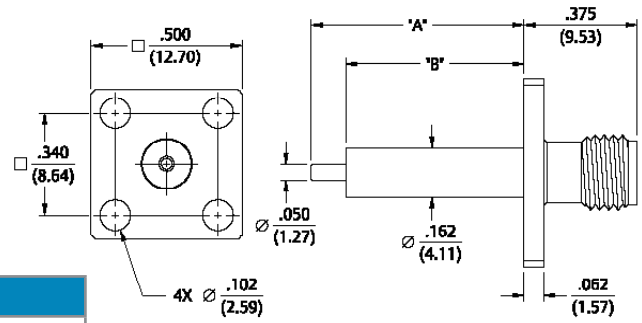

Gold Plated	Nickel Plated	"A"	"B"
142-1701-121	142-1701-126	.705 (17.91)	.590 (14.99)
142-1701-041	142-1701-046	.190 (4.83)	.095 (2.41)

4-Hole Flange Mount Jack Receptacle – Extended Dielectric

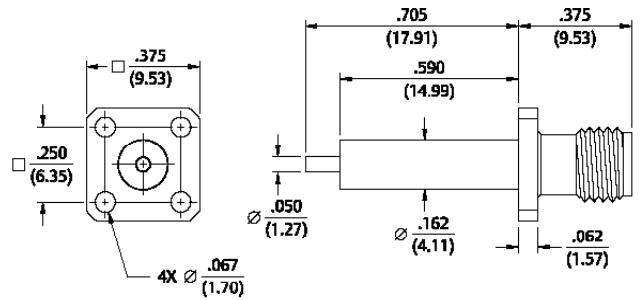

Gold Plated	Nickel Plated
142-1701-011	142-1701-016

2-Hole Flange Mount Jack Receptacle – Extended Dielectric

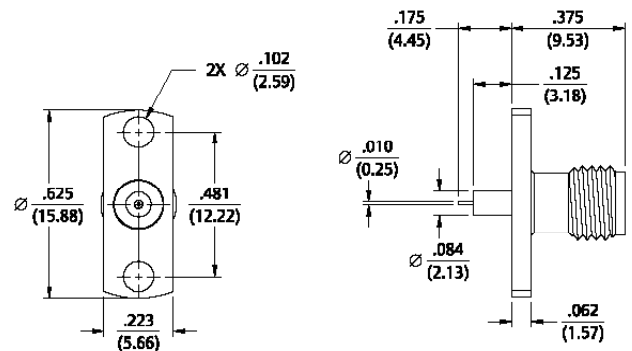

Gold Plated	Nickel Plated
142-1701-201	142-1701-206

4-Hole Flange Mount Jack Receptacle – Extended Dielectric



Gold Plated	Nickel Plated
142-1701-191	142-1701-196

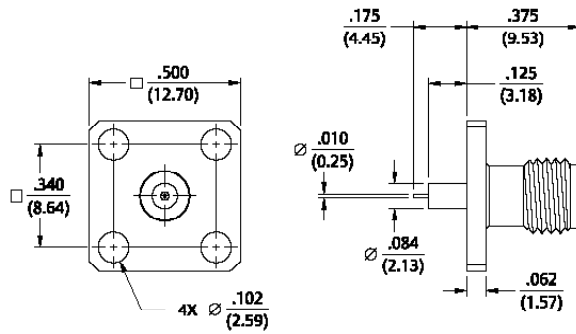

4-Hole Right Angle Flange Mount Jack Receptacle – Extended Dielectric



Gold Plated	Nickel Plated
142-0701-701	142-0701-706

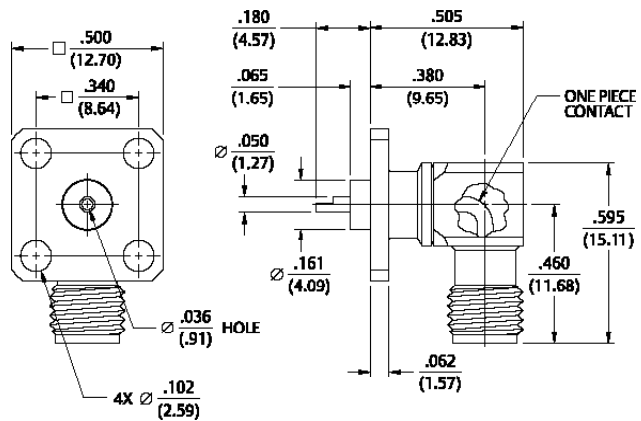

4-Hole Right Angle Flange Mount Jack Receptacle – Extended Dielectric



Gold Plated	Nickel Plated
142-1711-001	142-1711-006

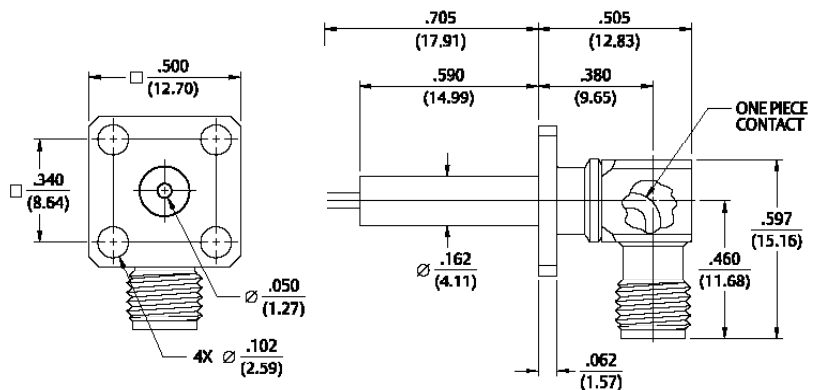

For more information, please contact customer service at (507) 833-8822 or (800) 247-8256 • cinch.com
 Illustrations are shown in inches (millimeters).

Panel Mount

2-Hole Right Angle Flange Mount Jack Receptacle – Extended Dielectric 90° Orientation

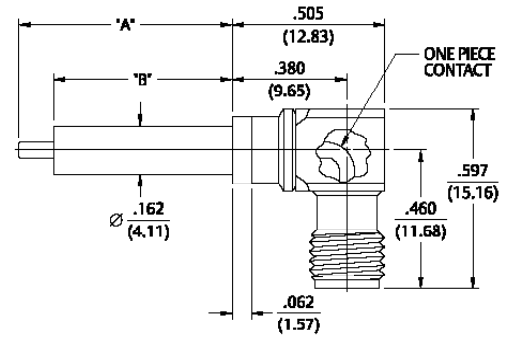
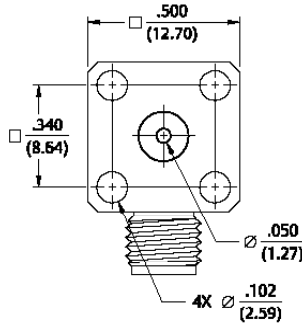

Gold Plated	Nickel Plated	"A"	"B"
142-1711-011	142-1711-016	.705 (17.91)	.590 (14.99)
142-1711-061	142-1711-066	.195 (4.95)	.130 (3.30)

2-Hole Right Angle Flange Mount Jack Receptacle – Extended Dielectric +45° Orientation

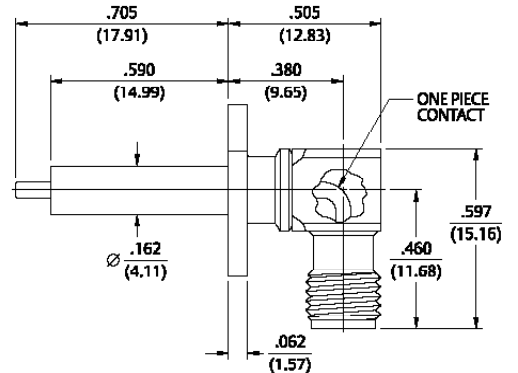
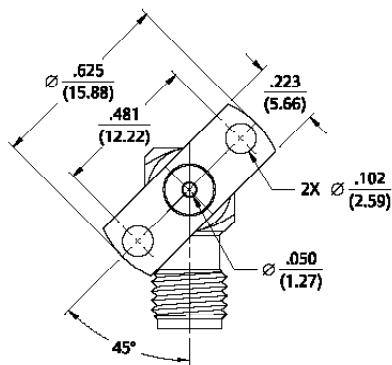

Gold Plated	Nickel Plated
142-1711-021	142-1711-026

2-Hole Right Angle Flange Mount Jack Receptacle – Extended Dielectric -45° Orientation

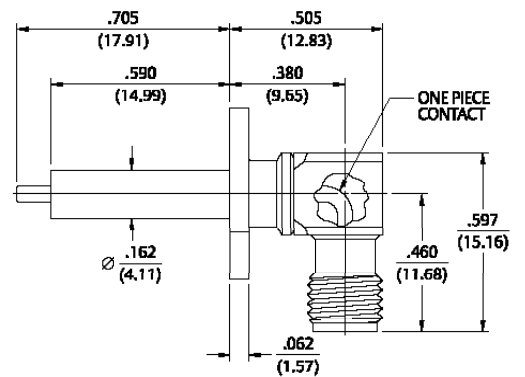
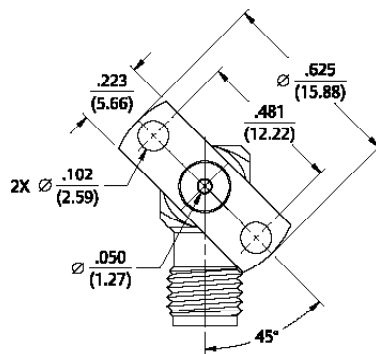

Gold Plated	Nickel Plated
142-1711-031	142-1711-036

Application Notes

The field replaceable style of connector is known by many names in the industry, such as MIC launcher, hermetic seal launcher, spark plug launcher, etc. Some types, such as those known as “spark plugs,” have the hermetic seal incorporated into the connector. These types require special welding to install and can not be replaced without destroying the hermeticity of the circuit housing. True field replaceable connectors, such as the Johnson line, are easy to install and replace. Because the hermetic seal is not incorporated into the connector design, the connector can be removed and replaced without destroying the hermetic seal or the hermeticity of the circuit housing.

All of the above-mentioned connector types perform the same basic function—creating a transition from microstrip circuitry to a coaxial transmission line. Whenever possible, the hermetic seal pin diameter should be chosen as close as possible to the microstrip trace width. For optimum electrical performance, the transition from the hermetic seal to the microstrip trace must be properly compensated which involves adjusting the microstrip trace width to minimize any impedance discontinuities found in the transition area.

The plot shown below is representative of the typical return loss of a Johnson SMA field replaceable connector. To produce the data shown below, a test fixture is created using the appropriate Johnson hermetic seal. The fixture consists of a suitably thick spacer plate with the hermetic seal mounted flush to both surfaces. Two connectors are mounted back to back around the fixture and the VSWR of this test assembly is measured. The return loss data shown is equivalent to the square root of the measured VSWR of the test assembly. Since the connectors tested are of identical design, it can be stated with fair accuracy that the data shown represents the response of a single field replaceable connector and its transition to the hermetic seal.

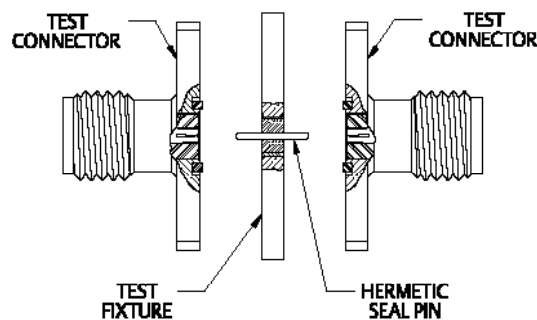

Although we do not publish a VSWR specification for field replaceable connectors, typical connector VSWR can be expected to be better than $1.1 + .01f$ ($f = \text{GHz}$). A VSWR specification is not stated because an industry standardized method for testing field replaceable connectors does not exist. The actual performance of the connector is dependent upon the application for the following reasons:

1. The choice of hermetic seal to be used by the customer is not specified by the connector manufacturer. Hermetic seals produced by different manufacturers will not have the same electrical characteristics. For optimum electrical performance, we recommend the use of our standard 142-1000-001, 002, 003 and 004 hermetic seals for pin diameters of .012 (.30), .015 (.38), .018 (0.46) and .020 (0.51). Custom hermetic seal configurations can be quoted.
2. It is recommended that the hermetic seal be mounted flush with the circuit housing. Tolerance variations between the hermetic seal and machined housing do not always guarantee an optimum transition to the connector. Emerson does not recommend the addition of a counter bore in the circuit housing to accommodate solder washers as solder voids will cause electrical discontinuities.
3. As stated above, the transition between the hermetic seal pin and the microstrip trace will affect electrical performance. Several different methods of hermetic seal mounting and seal pin to microstrip trace attachment are used in the industry. We cannot recommend one method over the other as this is dependent upon the customer's application.

“As always, quotes for non-standard field replaceable connectors and/or hermetic seals are welcome.”

For more information, please contact customer service at (507) 833-8822 or (800) 247-8256 • cinch.com

Illustrations are shown in inches (millimeters).

Field Replaceable Panel Mount

2-Hole Flange Mount Jack Receptacle – with EMI Gasket



Accepts Pin Size	Gold Plated	Nickel Plated
.012 (0.30)	142-1701-601	142-1701-606
.015 (0.38)	142-1701-611	142-1701-616
.018 (0.46)	142-1701-621	142-1701-626

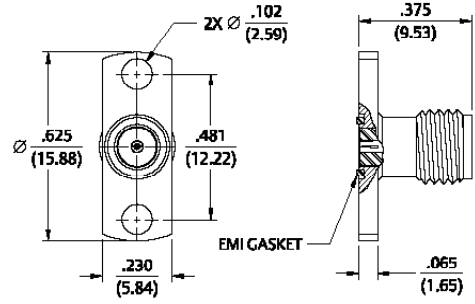

2-Hole Flange Mount Jack Receptacle – without EMI Gasket



Accepts Pin Size	Gold Plated	Nickel Plated
.020 (0.51)	142-1701-631	142-1701-636
.036 (0.91)	142-1701-641	142-1701-646

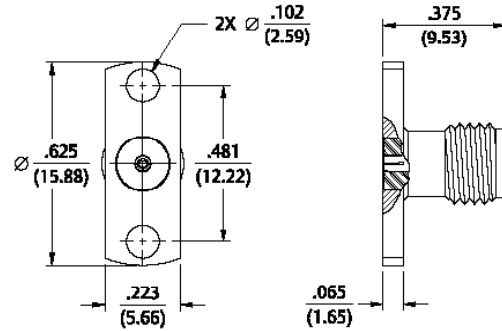

4-Hole Flange Mount Jack Receptacle – with EMI Gasket



Accepts Pin Size	Gold Plated	Nickel Plated
.012 (0.30)	142-1701-501	142-1701-506
.015 (0.38)	142-1701-511	142-1701-516
.018 (0.46)	142-1701-521	142-1701-526

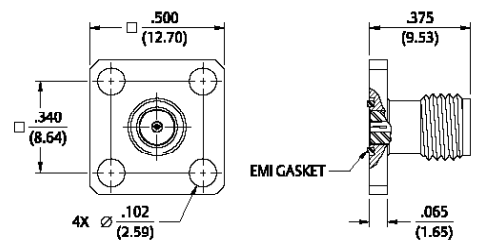

4-Hole Flange Mount Jack Receptacle – without EMI Gasket

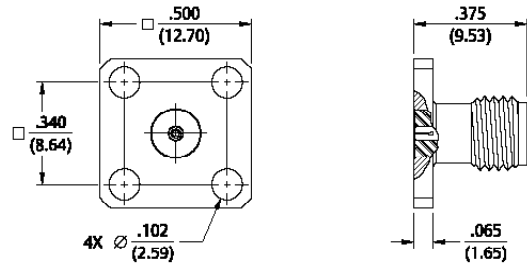

Accepts Pin Size	Gold Plated	Nickel Plated
.020 (0.51)	142-1701-531	142-1701-536
.036 (0.91)	142-1701-541	142-1701-546

4-Hole Flange Mount Jack Receptacle – with EMI Gasket

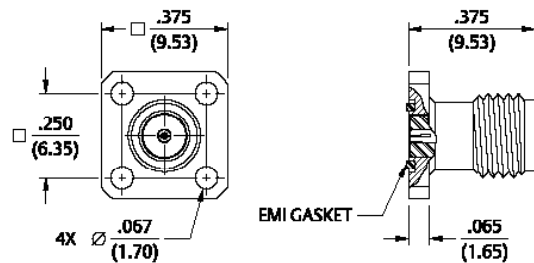

Accepts Pin Size	Gold Plated	Nickel Plated
.012 (0.30)	142-1701-551	142-1701-556
.015 (0.38)	142-1701-561	142-1701-566
.018 (0.46)	142-1701-571	142-1701-576

4-Hole Flange Mount Jack Receptacle – without EMI Gasket

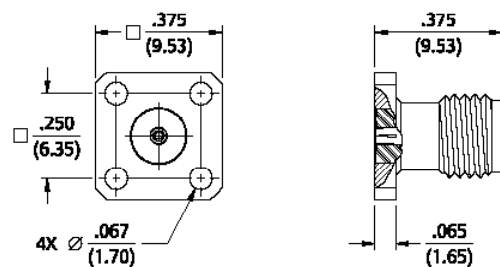

Accepts Pin Size	Gold Plated	Nickel Plated
.020 (0.51)	142-1701-581	142-1701-586
.036 (0.91)	142-1701-591	142-1701-596

For more information, please contact customer service at (507) 833-8822 or (800) 247-8256 • cinch.com

Illustrations are shown in inches (millimeters).

Field Replaceable Panel Mount

4-Hole Right Angle Flange Mount Jack Receptacle – with EMI Gasket

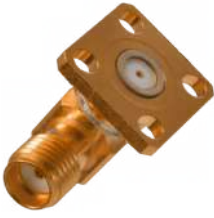

Accepts Pin Size	Gold Plated	Nickel Plated
.015 (0.38)	142-1711-511	142-1711-516
.018 (0.46)	142-1711-521	142-1711-526

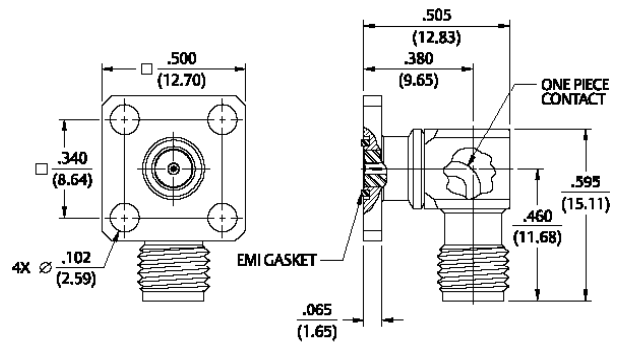

2-Hole Flange Mount Plug Receptacle – with EMI Gasket



Accepts Pin Size	Gold Plated	Nickel Plated
.012 (0.30)	142-1801-601	142-1801-606
.015 (0.38)	142-1801-611	142-1801-616
.018 (0.46)	142-1801-621	142-1801-626

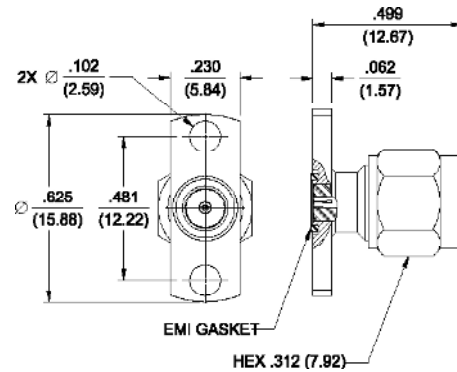

4-Hole Flange Mount Plug Receptacle – with EMI Gasket



Accepts Pin Size	Gold Plated	Nickel Plated
.012 (0.30)	142-1801-551	142-1801-556
.015 (0.38)	142-1801-561	142-1801-566
.018 (0.46)	142-1801-571	142-1801-576

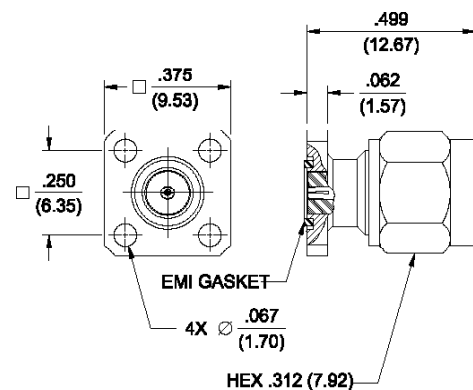

Hermetic Seal Feedthrough

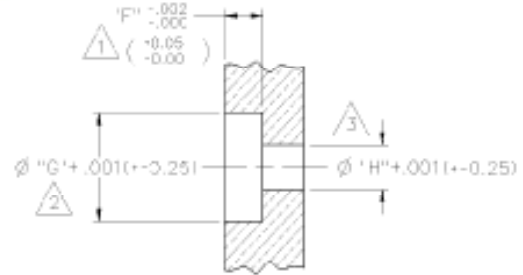
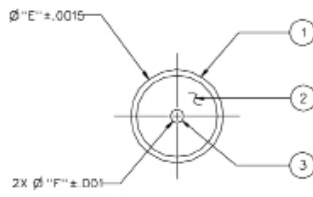
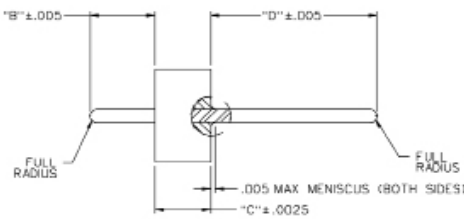

Recommended Mounting Hole Detail

Part No.	Item 1 Outer Ring	Item 2 Insulator	Item 3 Pin	"A"	"B"	"C"	"D"	"E"
142-1000-001	Kovar Gold pl .00005 min over Nickel pl .000005 min	Glass Corning 7052 or equivalent	Kovar Gold pl .00005 min over Nickel pl .000005 min	.070 (1.78)	.0625 (1.59)	.180 (4.57)	.0985 (2.50)	.012 (0.30)
142-1000-002	Kovar Gold pl .00005min over Nickel pl .000005 min	Glass Corning 7070 or equivalent	Kovar Gold pl .00005 min over Nickel pl .000005 mm	.072 (1.83)	.0625 (1.59)	.180 (4.57)	.0985 (2.50)	.015 (0.38)
142-1000-003	Kovar Gold pl .00005 min over Nickel pl .000005 min	Glass Corning 7050 or equivalent	Kovar Gold pl .00005 min over Nickel pl .000005 min	.072 (1.83)	.0600 (1.52)	.180 (4.57)	.1100 (2.79)	.018 (0.46)
142-1000-004	Kovar Gold pl .00005min over Nickel pl .000005 min	Glass Corning 7052 or equivalent	Kovar Gold pl .00005 min over Nickel pl .000005 min	.070 (1.78)	.0600 (1.52)	.203 (5.16)	.1580 (4.01)	.020 (0.51)

Mounting Hole Dimensions

Part No.	Pin Diameter	"F"	"G"	Air "H"	Teflon * "H"
142-1000-001	.012 (0.30)	.063 (1.60)	.102 (2.59)	.028 (0.71)	.039 (0.99)
142-1000-002	.015 (0.38)	.063 (1.60)	.102 (2.59)	.035 (0.89)	.049 (1.24)
142-1000-003	.018 (0.46)	.060 (1.52)	.114 (2.90)	.042 (1.07)	.059 (1.50)
142-1000-004	.020 (0.51)	.060 (1.52)	.162 (4.11)	.046 (1.17)	.065 (1.65)

* Teflon is a registered trademark of DuPont

Notes:

1. The hermetic seal should be mounted as flush as possible with the housing. Excessive recession will create a high impedance air gap which degrades electrical performance.
2. The use of an additional counterbore to accommodate a solder ring for seal mounting is not recommended. A slight chamfer may be used if care is taken to completely fill the area with solder—avoid air gaps.
3. Dimensions shown are given to achieve 50 Ohms with either air or a teflon insulator. A teflon insulator may be helpful insupporting small pin diameters.

Electrical

Impedance:	50 Ohms
Frequency Range:	DC to 26.5 GHz
VSWR:	Dependent upon application 250 VRMS max at sea level
Working Voltage:	500 VRMS min at sea level
Dielectric Withstanding Voltage:	5000 Megohm min
Insulation Resistance:	.015F dB max (F in GHz)
Insertion Loss:	

Environmental

Hermeticity:	1x10 ⁻⁸ cc/sec at one atmosphere
Solderability:	MIL-STD-202, Method 209
Operating Temperature:	-55° C to +165° C

For more information, please contact customer service at (507) 833-8822 or (800) 247-8256 • cinch.com

Illustrations are shown in inches (millimeters).

In-Series Adapters

Jack to Jack Adapter

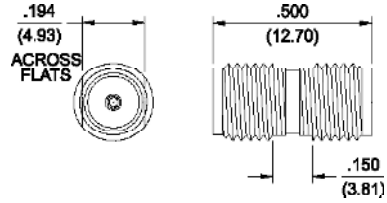

Gold Plated	Nickel Plated
142-0901-801	142-0901-806

Jack to Bulkhead Jack Adapter

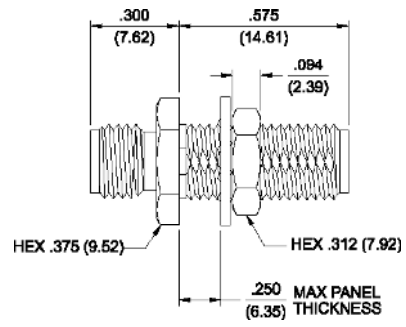

Gold Plated	Nickel Plated
142-0901-401	142-0901-406

Plug to Plug Adapter

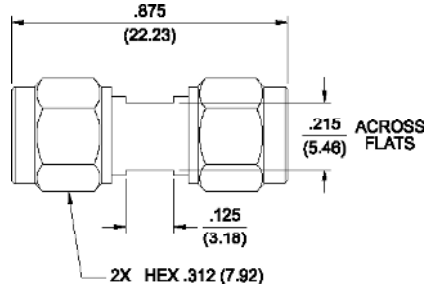

Gold Plated	Nickel Plated
142-0901-811	142-0901-816

Plug to Jack Adapter

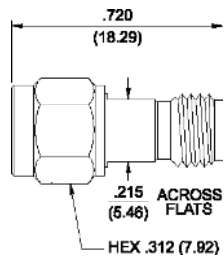

Gold Plated	Nickel Plated
142-0901-821	142-0901-826

Right Angle Jack to Jack Adapter

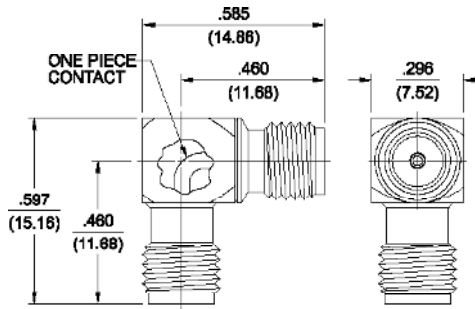

Gold Plated

142-0901-921

Right Angle Plug to Plug Adapter

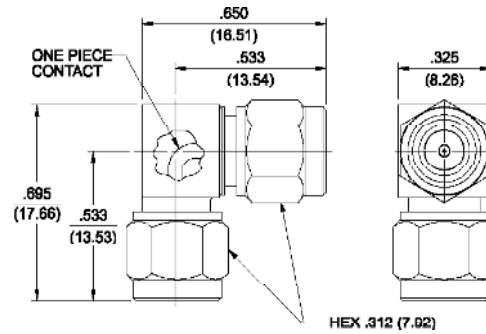

Gold Plated

142-0901-931

Right Angle Jack to Plug Adapter

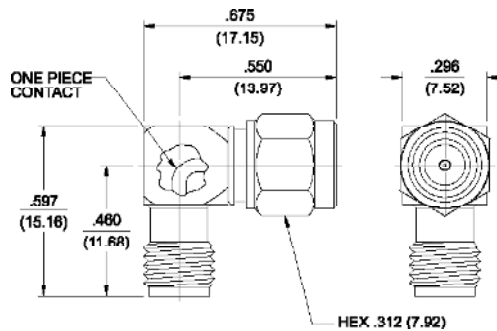

Gold Plated

142-0901-941

Dummy Load Plug

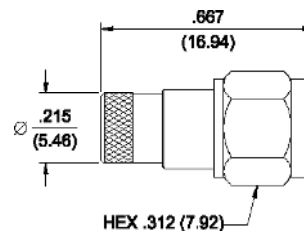

Gold Plated	Nickel Plated	Resistance
142-0801-861	142-0801-866	50 Ohm

For more information, please contact customer service at (507) 833-8822 or (800) 247-8256 • cinch.com
Illustrations are shown in inches (millimeters).

Specifications

Electrical Specifications

Impedance: 50 Ohms

Frequency Range:

Flexible cable connectors.....0-12.4 GHz

Flexible cable connectors.....0-18.0 GHz

VSWR: (max) (f = GHz)

	Straight Cabled Connectors	Right Angle Cabled Connectors
RG-316, LMR-100 cable.....	1.15 + .02f	1.15 + .03f
RG-58, LMR-195 cable.....	1.17 + .025f	1.17 + .06f
RG-142 cable.....	1.17 + .02f	1.15 + .03f
LMR-200, LMR-240 cable.....	1.10 + .03f	1.10 + .06f
Uncabled receptacles.....	N/A	

Working Voltage: (VRMS max)

	Sea Level	70K Feet
RG-316, LMR-100, 195, 200.....	250	65
RG-58, RG-142, LMR-240, uncabled receptacles.....	335	85

Dielectric Withstanding Voltage: (VRMS min at sea level)

RG-316; LMR-100, 195, 200.....	750
RG-58, RG-142, LMR-240, uncabled receptacles.....	1000

Insulation Resistance: 5000 megohms min

Contact Resistance: (milliohms max)

	Initial	After Environmental
Center contact (straight cabled connectors and uncabled receptacles).....	3.0	4.0
Center contact (right angle cabled connectors).....	4.0	6.0
Outer contact (all connectors).....	2.0	N/A
Braid to body (gold plated connectors).....	0.5	N/A
Braid to body (nickel plated connectors).....	5.0	N/A

Corona Level: (Volts min at 70,000 feet)

RG-316, LMR-100, 195, 200.....	190
RG-58, RG-142, LMR-240, uncabled receptacles.....	250

Insertion Loss: (dB max)

Straight flexible cable connectors.....	$0.06 \sqrt{f \text{ (GHz)}}$, tested at 6 GHz
Right angle flexible cable connectors.....	$0.15 \sqrt{f \text{ (GHz)}}$, tested at 6 GHz
Low loss flexible straight cable connectors.....	$0.06 \sqrt{f \text{ (GHz)}}$, tested at 1 GHz
Low loss flexible right angle cable connectors.....	$0.15 \sqrt{f \text{ (GHz)}}$, tested at 1 GHz
Uncabled receptacles, field replaceable.....	N/A

RF Leakage: (dB min, tested at 2.5 GHz)

Flexible cable connectors.....	-60 dB
Uncabled receptacles and adapters.....	N/A

RF High Potential Withstanding Voltage:

(VRMS min tested at 4 and 7 MHz)† RG-316; LMR-100, 195, 200..... 500

RG-58, RG-142, LMR-240, uncabled receptacles..... 670

† Avoid user injury due to misapplication. See safety advisory definitions.

Mechanical Ratings

Engagement Design:

Reverse Polarity, Series SMA

Engagement/Disengagement Force:

2 lb-in max max

Mating Torque:

7 to 10 lb-in

Bulkhead Mounting Nut Torque:

15 lb-in

Coupling Proof Torque:

15 lb-in min

Coupling Nut Retention:

60 lbs min

Contact Retention:

6 lbs min axial force (captivated contacts)

4 oz-in min 4 oz-in min

Cable Retention:

	Axial Force* (lbs)	Torque (oz-in)
Connectors for RG-316, LMR-100.....	20	N/A
Connectors for LMR195, 200.....	30	N/A
Connectors for RG-58, LMR-240.....	40	N/A
Connectors for RG-142.....	45	N/A

*Or cable breaking strength whichever is less.

Durability: 500 cycles minimum

Environmental Specifications

(Meets or Exceeds the Applicable Paragraph of MIL-PRF-39012)

- Temperature Range:** - 65°C to + 165°C
- Thermal Shock:** MIL-STD-202, Method 107, Condition B
- Corrosion:** MIL-STD-202, Method 101, Condition B
- Shock:** MIL-STD-202, Method 213, Condition I
- Vibration:** MIL-STD-202, Method 204, Condition D
- Moisture Resistance:** MIL-STD-202, Method 106

Material Specifications

- Bodies:** Brass per ASTM B16, gold plated* per MIL-DTL-45204 .00001" min or nickel plated per ASTM B16
- Contacts:** Male - brass per QQ-B-626, gold plated per MIL-DTL-45204 .00003" min
Female - beryllium copper per ASTM B196, gold plated* per MIL-DTL-45204 .00003" min
- Nut Retention Spring:** Beryllium copper per ASTM B196, unplated
- Insulators:** PTFE fluorocarbon per ASTM D 1710 and ASTM D 1457 or Tefzel per ASTM D 3159
- Expansion Caps:** Brass per ASTM B16, gold plated* per MIL-DTL-45204 .00001" min. or nickel plated per SAE-AMS2423
- Crimp Sleeves:** Copper per ASTM B301 or brass per ASTM B16, gold plated* per MIL-DTL-45204 .00001" min or nickel plated per SAE-AMS2423
- Mounting Hardware:** Brass (nuts) per ASTM B16 or phosphor bronze (lockwashers) per ASTM B139, gold plated* per MIL-DTL-45204 .00001" min

* All gold plated parts include a .00005" min nickel barrier layer.
 † Avoid user injury due to misapplication. See safety advisory definitions.

Mating Engagement for SMA Reverse Polarity Series

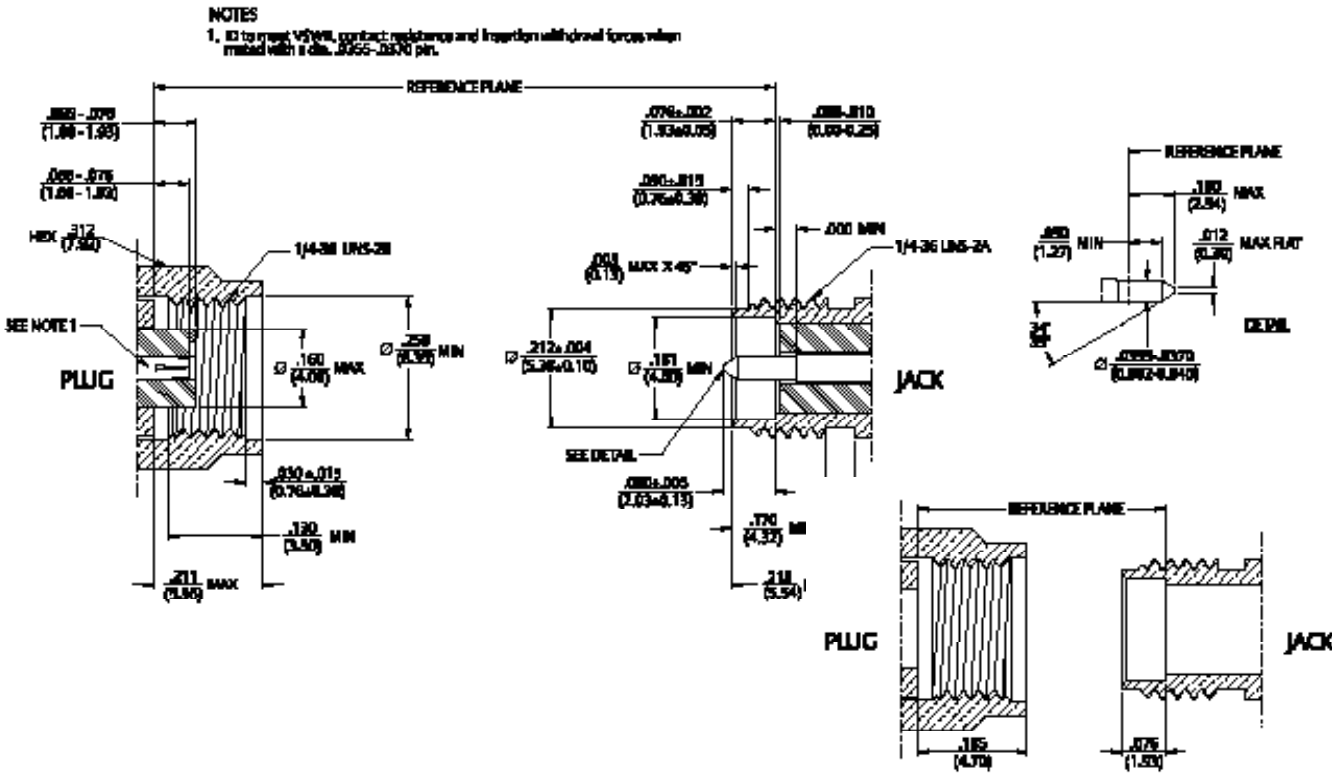

For more information, please contact customer service at (507) 833-8822 or (800) 247-8256 • cinch.com
 Illustrations are shown in inches (millimeters).

Flexible Cable

Straight Crimp Type Plug – Solder or Crimp Captivated Contact

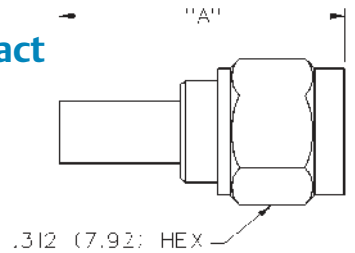

Cable Type	Gold Plated	Nickel Plated	"A"
RG-316/U, 188, 174, 161, LMR-100 HPF-100, RF-100	142-4403-001	142-4403-006	.706 (17.93)
RG-316 DS, 188 DS	142-4404-001	142-4404-006	.706 (17.93)
RG-58, 141, 303 LMR-195, HPF-195, RF-195	142-4407-001	142-4407-006	.706 (17.93)
RG-142, 55, 223, 400	142-4408-001	142-4408-006	.706 (17.93)
LMR-200, HPF-200, RF-200	142-4439-001	142-4439-006	.844 (21.44)
LMR-240, HPF-240, RF-240	142-4435-001	142-4435-006	.844 (21.44)

Assembly Instructions: LMR 195, 200 and 240 page 219. All other cables page 220.

Right Angle Crimp Type Plug – Captivated Contact

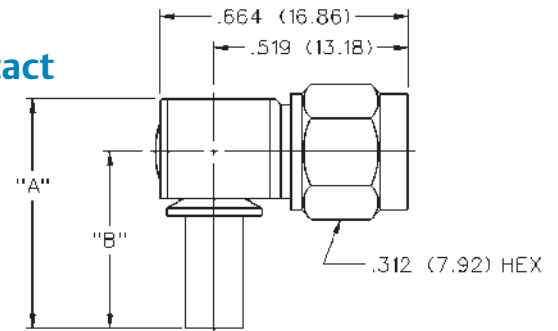

Cable Type	Gold Plated	Nickel Plated	"A"	"B"
RG-316, 188, 174, 161, LMR-100, HPF-100, RF-100	142-4403-101	142-4403-106	.611 (15.52)	.470 (11.94)
RG-316 DS, 188 DS	142-4404-101	142-4404-106	.611 (15.52)	.470 (11.94)
RG-58, 141, 303, LMR-195, HPF-195, RF-195	142-4407-101	142-4407-106	.611 (15.52)	.470 (11.94)
RG-142, 55, 223, 400	142-4408-101	142-4408-106	.611 (15.52)	.470 (11.94)
LMR-200, HPF-200, RF-200	142-4439-101	142-4439-106	.611 (15.52)	.470 (11.94)
LMR-240, HPF-240, RF-240	142-4435-101	142-4435-106	.635 (16.13)	.490 (12.45)

Assembly Instructions: LMR 195, 200 and 240 page 224. All other cables page 229.
Center conductor of cable serves as contact.

Straight Crimp Type Bulkhead Jack – Captivated Contact

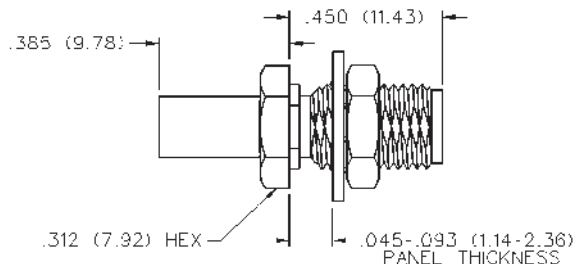

Cable Type	Gold Plated	Nickel Plated
RG-316, 188, 174, 161	142-4303-401	142-4303-406
RG-316 DS, 188 DS	142-4304-401	142-4304-406
RG-58, 141, 303	142-4307-401	142-4307-406
RG-142, 55, 223, 400	142-4308-401	142-4308-406

Assembly instructions page 219.
Mounting hole layout figure 1 page 194.

Straight Jack Receptacle

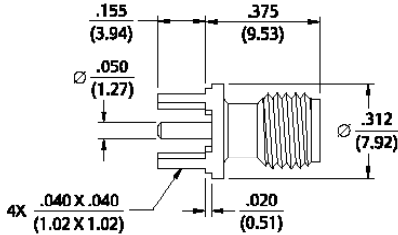

Gold Plated	Nickel Plated
142-4701-201	142-4701-206

Mounting hole layout figure 2 page 194.

Right Angle Bulkhead Jack Receptacle

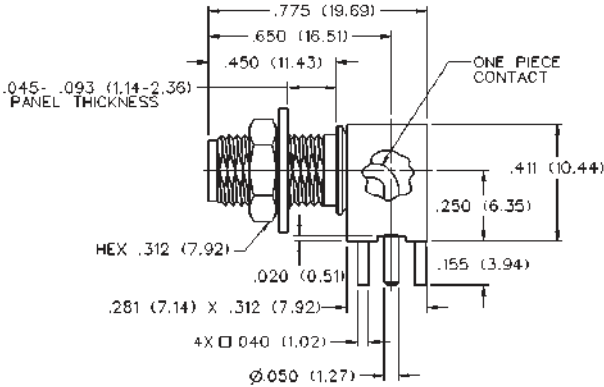

Gold Plated	Nickel Plated
142-4701-501	142-4701-506

Mounting hole layout figure 1 and 2 page 194.

End Launch Bulkhead Jack Receptacle

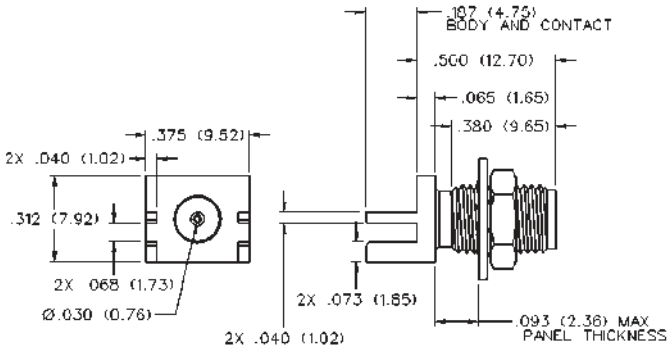

Gold Plated	Nickel Plated	Board Thickness
142-4701-801	142-4701-806	.062 (1.57)

For more information, please contact customer service at (507) 833-8822 or (800) 247-8256 • cinch.com
 Illustrations are shown in inches (millimeters).

Specifications

Electrical Specifications

Impedance: 50 Ohms

Frequency Range:

Flexible cable connectors..... 0-12.4 GHz

Uncabled receptacles..... 0-18.0 GHz

VSWR: (max) (f = GHz)

	Straight Cabled Connectors	Right Angle Cabled Connectors
RG-316, LMR-100 cable.....	1.15 + .02f	1.15 + .03f
RG-58, LMR-195 cable.....	1.15 + .01f	1.15 + .02f
RG-142 cable.....	1.15 + .01f	1.15 + .02f
LMR-200, LMR-240 cable.....	1.10 + .03f	1.10 + .06f
Uncabled receptacles.....	N/A	

Working Voltage: (VRMS max)

	Sea Level	70K Feet
RG-316; LMR-100, 195, 200.....	250	65
RG-58, RG-142, LMR-240, uncabled receptacles.....	335	85

Dielectric Withstanding Voltage: (VRMS min at sea level)

RG-316; LMR-100, 195, 200.....	750
RG-58, RG-142, LMR-240, uncabled receptacles.....	1000

Insulation Resistance: 5000 megohms min

Contact Resistance: (milliohms max)

	Initial	After Environmental
Center contact (straight cabled connectors and uncabled receptacles).....	3.0	4.0
Center contact (right angle cabled connectors).....	4.0	6.0
Outer contact (all connectors).....	2.0	N/A
Braid to body (gold plated connectors).....	0.5	N/A
Braid to body (nickel plated connectors).....	5.0	N/A

Corona Level: (Volts min at 70,000 feet)†

RG-316, LMR-100, 195, 200.....	190
RG-58, RG-142, LMR-240, uncabled receptacles.....	250

Insertion Loss: (dB max)

Straight flexible cable connectors.....	$0.06 \sqrt{f \text{ (GHz)}}$	tested at 6 GHz
Right angle flexible cable connectors.....	$0.15 \sqrt{f \text{ (GHz)}}$	tested at 6 GHz
Low loss flexible straight cable connectors.....	$0.06 \sqrt{f \text{ (GHz)}}$	tested at 1 GHz
Low loss flexible right angle cable connectors.....	$0.15 \sqrt{f \text{ (GHz)}}$	tested at 1 GHz
Uncabled receptacles, field replaceable.....	N/A	

RF Leakage: (dB min tested at 2.5 GHz)

† Avoid user injury due to misapplication. See safety advisory definitions.

Mechanical Ratings

Engagement Design: Reverse Thread, Series SMA

Engagement/Disengagement Force: 2 lb-in max

Mating Torque: 7 to 10 lb-in

Bulkhead Mounting Nut Torque: 15 lb-in

Coupling Proof Torque: 15 lb-in min

Coupling Nut Retention: 60 lbs min

Contact Retention: 6 lbs. min axial force (captivated contacts)

4 oz-in min torque (uncabled receptacles)

Cable Retention:

	Axial Force* (lbs)	Torque (oz-in)
RG-316, LMR-100.....	20	N/A
LMR195, 200.....	30	N/A
RG-58, LMR-240.....	40	N/A
RG-142.....	45	N/A

*Or cable breaking strength whichever is less.

Durability: 500 cycles min

Environmental Specifications

(Meets or Exceeds the Applicable Paragraph of MIL-PRF-39012)

- Temperature Range:** - 65°C to + 165°C
- Thermal Shock:** MIL-STD-202, Method 107, Condition B
- Corrosion:** MIL-STD-202, Method 101, Condition B
- Shock:** MIL-STD-202, Method 213, Condition I
- Vibration:** MIL-STD-202, Method 204, Condition D
- Moisture Resistance:** MIL-STD-202, Method 106

Material Specifications

- Bodies:** Brass per ASTM B16, gold plated* per MIL-DTL-45204 .00001" min or nickel plated per ASTM B16
- Contacts:** Male - brass per QQ-B-626, gold plated* per MIL-DTL-45204 .00003" min
Female - beryllium copper per ASTM B196, gold plated* per MIL-DTL-45204 .00003" min
- Nut Retention Spring:** Beryllium copper per ASTM B196. Unplated
- Insulators:** PTFE fluorocarbon per ASTM D1710 and ASTM D1457 or Tefzel per ASTM D 3159
- Expansion Caps:** Brass per ASTM B16, gold plated per MIL-DTL-45204 .00001" min or nickel plated* per SAE-AMS2423
- Crimp Sleeves:** Copper per ASTM B301 or brass per ASTM B301, gold plated* per MIL-DTL-45204 .00001" min or nickel plated per SAE-AMS2423
- Mounting Nut:** Brass per ASTM B16, green chromate over zinc plated Mounting Lockwasher: Phosphor bronze per ASTM B139, gold plated* per MIL-DTL-45204 .00001" min or nickel plated per SAE-AMS2423

* All gold plated parts include a .00005" min nickel barrier layer.

† Avoid user injury due to misapplication. See safety advisory definitions.

Mating Engagement for SMA Reverse Thread Series

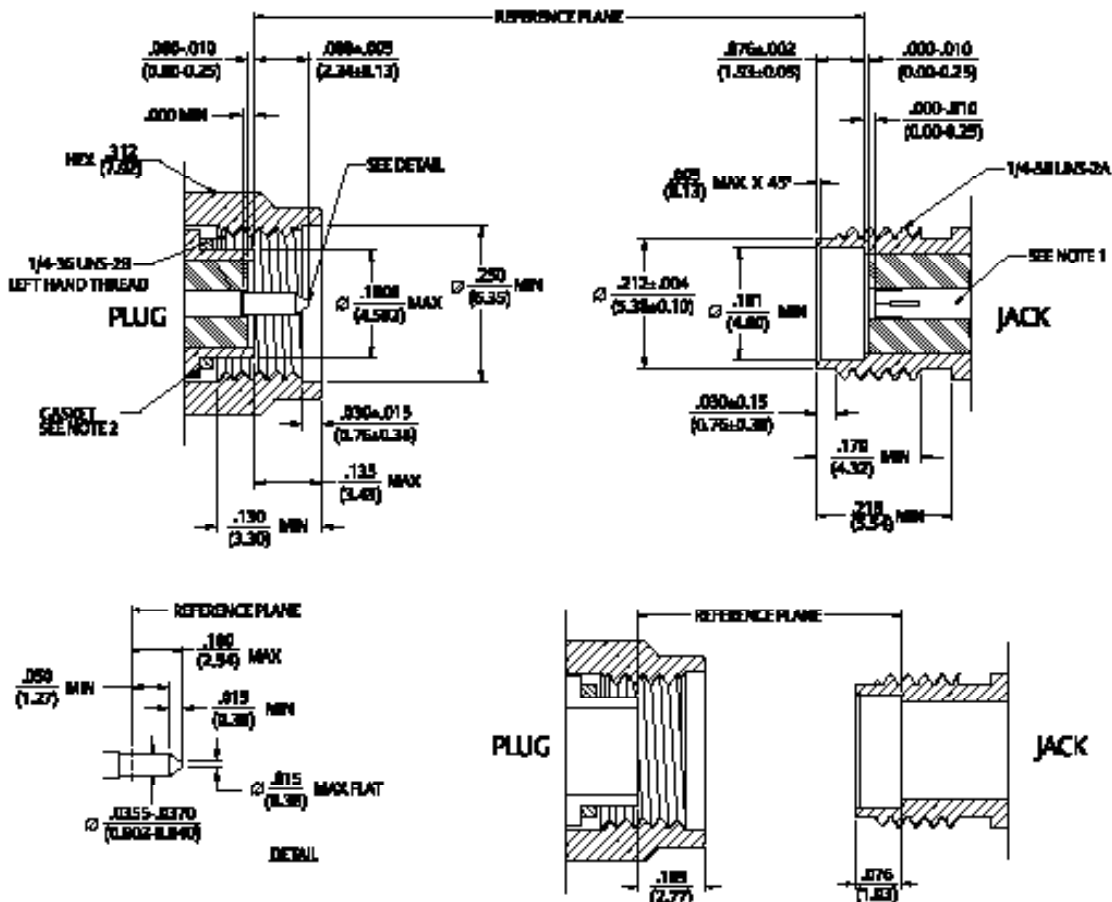

For more information, please contact customer service at (507) 833-8822 or (800) 247-8256 • cinch.com
Illustrations are shown in inches (millimeters).

Flexible Cable

Straight Crimp Type Plug – Solder or Crimp Captivated Contact

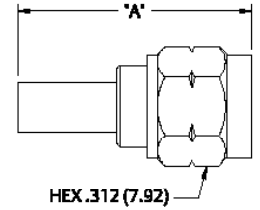

Cable Type	Gold Plated	Nickel Plated	"A"
RG-316, 188, 174, 161, LMR-100 HPF-100 RF-100	142-5403-001	142-5403-006	.706 (17.93)
RG-316 DS, 188 DS,	142-5404-001	142-5404-006	.706 (17.93)
RG-58, 141, 303 LMR-195, HPF-195, RF-195	142-5407-001	142-5407-006	.706 (17.93)
RG-142, 55, 223, 400	142-5408-001	142-5408-006	.706 (17.93)
LMR-200, HPF-200, RF-200	142-5439-001	142-5439-006	.844 (21.44)
LMR-240, HPF-240, RF-240	142-5435-001	142-5435-006	.844 (21.44)

Assembly Instructions: LMR 195, 200 and 240 page 220. All other cables page 219.

Right Angle Crimp Type Plug – Captivated Contact

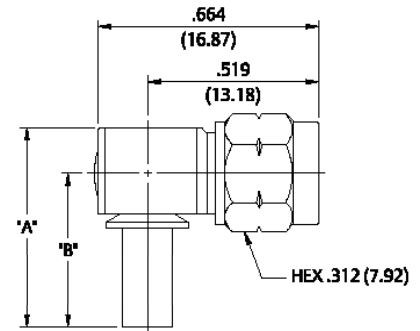

Cable Type	Gold Plated	Nickel Plated	A	B
RG-316, 188, 174, 161, LMR-100 HPF-100 RF-100	142-5403-101	142-5403-106	.611 (15.52)	.470 (11.94)
RG-316 DS 188 DS	142-5404-101	142-5404-106	.611 (15.52)	.470 (11.94)
RG-58, 141, 303, LMR-195 HPF-195 RF195	142-5407-101	142-5407-106	.611 (15.52)	.470 (11.94)
RG-142, 55, 223, 400	142-5408-101	142-5408-106	.611 (15.52)	.470 (11.94)
LMR-200 HPF-200 RF-200	142-5439-101	142-5439-106	.611 (15.52)	.470 (11.94)
LMR-240 HPF-240 RF-240	142-5435-101	142-5435-106	.635 (16.13)	.490 (12.45)

Assembly instructions: LMR 195, 200 and 240 page 229. All other cables page 224.

Straight Crimp Type Bulkhead Jack – Solder or Crimp

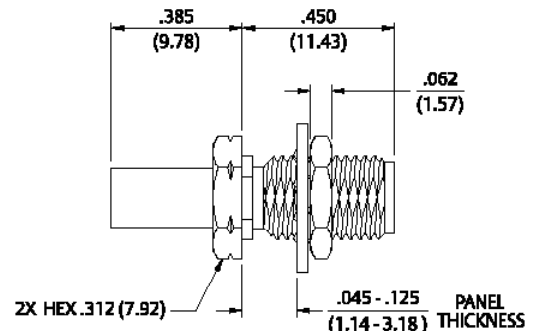

Cable Type	Gold Plated	Nickel Plated
RG-316, 188, 174, 161	142-5303-401	142-5303-406
RG-316 DS, 188 DS	142-5304-401	142-5304-406
RG-58, 141, 303	142-5307-401	142-5307-406
RG-142, 55, 223, 400	142-5308-401	142-5308-406

Assembly instructions page 219.
Mounting hole layout figure 1 page 194.

Straight Jack Receptacle



Gold Plated	Nickel Plated
142-5701-201	142-5701-206

Mounting hole layout figure 2 page 194.

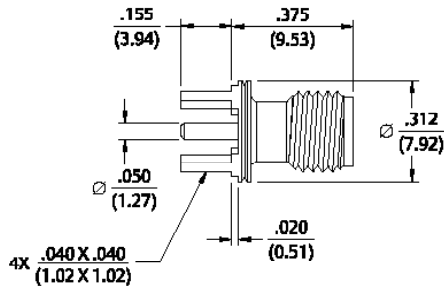

Right Angle Bulkhead Jack Receptacle



Gold Plated	Nickel Plated
142-5701-501	142-5701-506

Mounting hole layout figures 1 and 2 page 194.

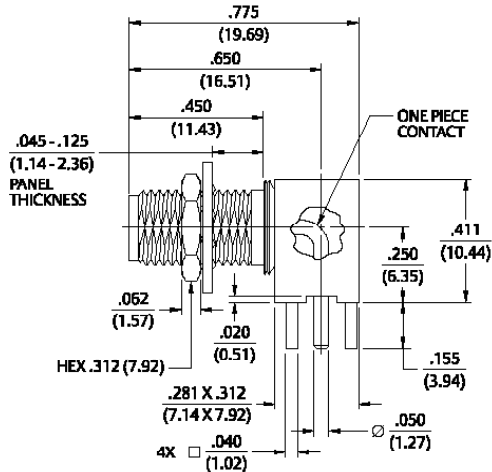

End Launch Bulkhead – Round Contact



Gold Plated	Nickel Plated	Board Thickness
142-5701-801	142-5701-806	.062 (1.57)

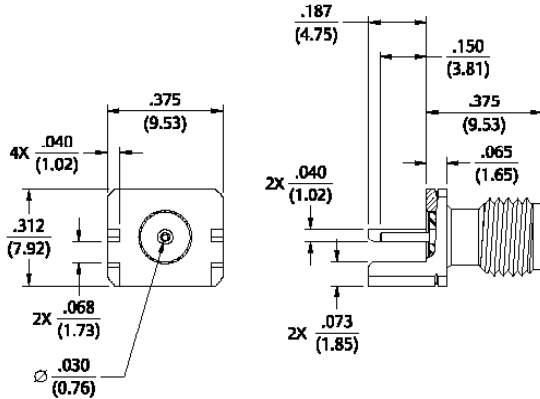

End Launch Bulkhead Jack Receptacle – Rou



Gold Plated	Nickel Plated	Board Thickness
142-5701-811	142-5701-816	.062 (1.57)

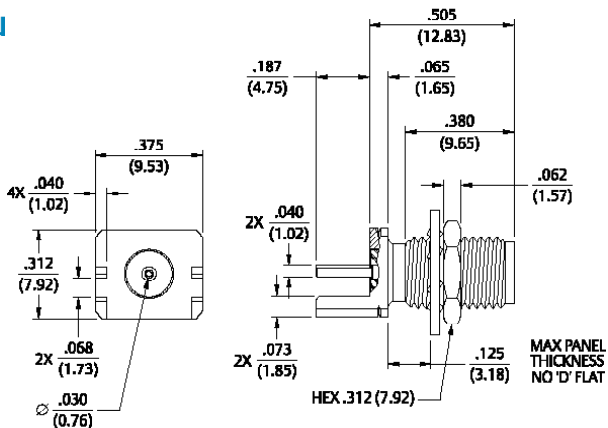

For more information, please contact customer service at (507) 833-8822 or (800) 247-8256 • cinch.com

Illustrations are shown in inches (millimeters).

Specifications

Electrical Specifications

Impedance: 50 Ohms

Frequency Range: Flexible cable connectors 0-12.4 GHz
 Uncabled receptacles 0-18.0 GHz

VSWR: (max) (f = GHz)	Straight	Right Angle
	<u>Cabled Connectors</u>	<u>Cabled Connectors</u>
RG-316 cable	1.15 + .02f	1.15 + .03f
RG-58 cable	1.15 + .01f	1.15 + .02f
Uncabled receptacles	N/A	
Working Voltage: (VRMS max)†	<u>Sea Level</u>	<u>70K Feet</u>
RG-316250	65
RG-58, uncabled receptacles335	85

Dielectric Withstanding Voltage: (VRMS min at sea level)†

RG-316	750
RG-58, uncabled receptacles	1000

Insulation Resistance: 5000 megohms min

Contact Resistance: (milliohms max)

	<u>Initial</u>	<u>After Environmental</u>
Center contact (straight cabled connectors, uncabled receptacles)	3.0	4.0
Center contact (right angle cabled connectors)	4.0	6.0
Outer contact (all connectors)	2.0	N/A
Braid to body	0.5	N/A

Corona Level: (Volts min at 70,000 feet)†

RG-316 190	
RG-58, uncabled receptacles	250

Insertion Loss: (dB max)

Straight flexible cable connectors	$0.06\sqrt{f \text{ (GHz)}}$, tested at 6 GHz
Right angle flexible cable connectors	$0.15\sqrt{f \text{ (GHz)}}$, tested at 6 GHz
Uncabled receptacles	N/A

RF Leakage: (dB min tested at 2.5 GHz)

Flexible cable connectors	-60 dB
Uncabled receptacles	N/A

RF High Potential Withstanding Voltage: (VRMS minimum, tested at 4 and 7 MHz)†

RG-316	500
RG-58, uncabled receptacles	670

† Avoid user injury due to misapplication. See safety advisory definitions inside front cover.

Mechanical Specifications

Engagement Design: MIL-STD-348, Series SMA

Engagement/Disengagement Force: 2 lb-in min max

Mating Torque: 7 to 10 lb-in min

Coupling Proof Torque: 15 lb-in min

Coupling Nut Retention: 60 lbs min

Contact Retention: 6 lbs min axial force (captivated contacts)

4 oz-in min torque (uncabled receptacles)

Cable Retention:	<u>Axial Force* (lbs)</u>	<u>Torque (oz-in)</u>
RG-316	20	N/A
RG-58	40	N/A

*Or cable breaking strength whichever is less.

Durability: 500 cycles min

Environmental Specifications

(Meets or Exceeds the Applicable Paragraph of MIL-PRF-39012)

Temperature Range: - 65°C to + 165°C

Thermal Shock: MIL-STD-202, Method 107, Condition B

Corrosion: MIL-STD-202, Method 101, Condition B

Shock: MIL-STD-202, Method 213, Condition I

Vibration: MIL-STD-202, Method 204, Condition D

Moisture Resistance: MIL-STD-202, Method 106

Material Specifications

(See non-magnetic materials page 10)

† Avoid user injury due to misapplication. See safety advisory definitions inside front cover.

Straight Crimp Type Plug (3-piece) – Captivated Contact

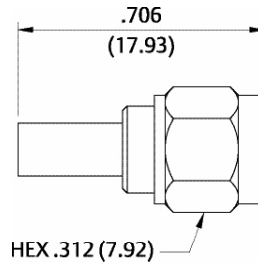

Cable Type	Gold Plated
RG-316, 188, 174	142-9403-011
RG-316 DS, 188 DS	142-9404-011
RG-58, 141, 303	142-9407-001

Assembly instructions page 219.

Right Angle Crimp Type Plug – Captivated Contact

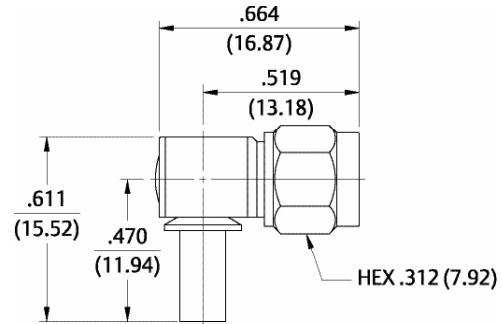

Cable Type	Gold Plated
RG-316, 188, 174	142-9403-101
RG-316 DS, 188 DS	142-9404-101
RG-58, 141	142-9407-101

Assembly instructions page 224.

Straight Crimp Type Bulkhead Jack (3-piece) – Captivated Contact

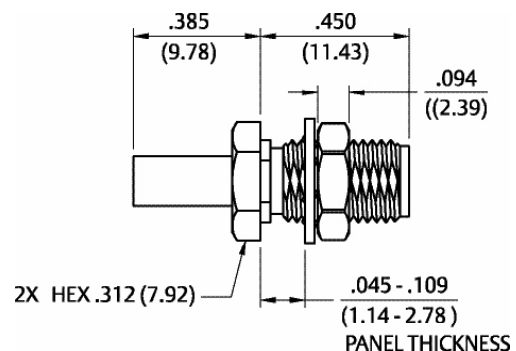

Cable Type	Gold Plated
RG-316, 188, 174	142-9303-411

Assembly instructions page 219.

For more information, please contact customer service at (507) 833-8822 or (800) 247-8256 • cinch.com

Illustrations are shown in inches (millimeters).

PC Mount

Straight Jack Receptacle



Gold Plated	"A"
142-9701-201	.155 (3.94)
142-9701-211	.110 (2.79)

Mounting hole layout figure 3 on page 194.

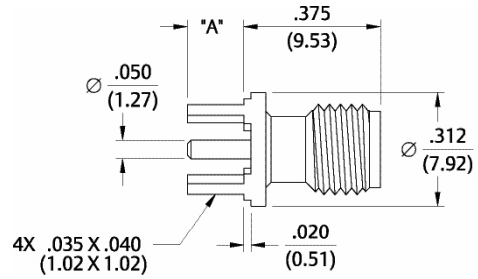

Straight Plug Receptacle



Gold Plated
142-9801-201

Mounting hole layout figure 3 on page 194.

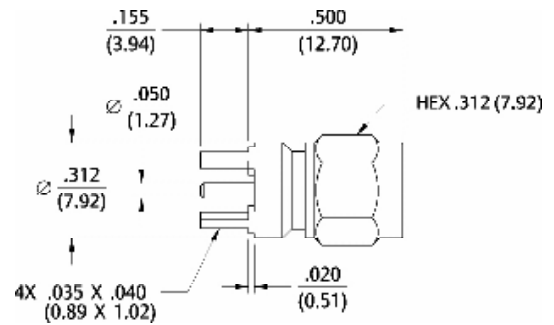

Right Angle Jack Receptacle



Gold Plated
142-9701-301

Mounting hole layout figure 3 on page 194.

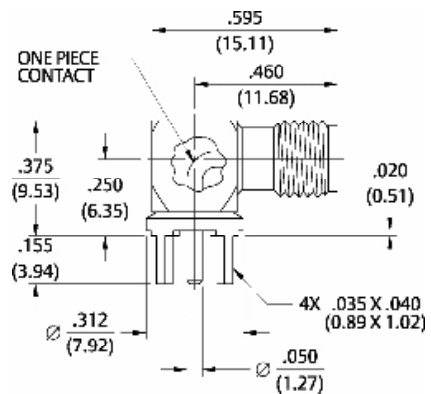

End Launch Jack Receptacle – Round Contact



Gold Plated	Board Thickness
142-9701-801	.062 (1.57)

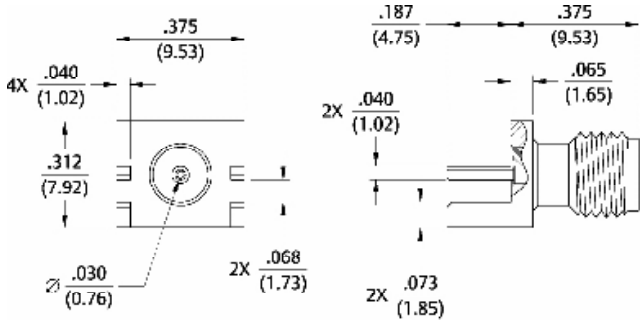

End Launch Jack Receptacle – Tab Contact



Gold Plated	Board Thickness
142-9701-811	.062 (1.57)

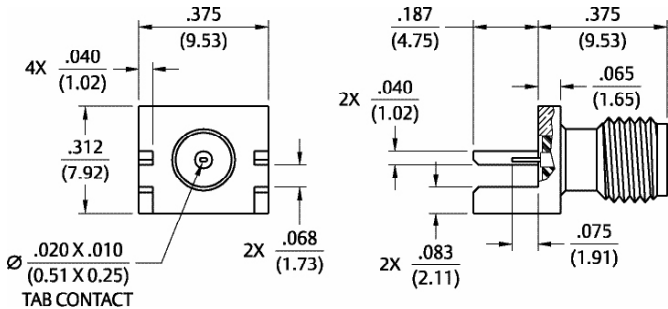

Specifications

Electrical Specifications

Impedance: 50 Ohms
Frequency Range: 0-26.5 GHz
VSWR: (max) 1.05+.02f(GHz) max at 0-18 GHz, <1.50 typical at 18-26.5 GHz
Working Voltage: 170 VRMS max at sea level, 45 VRMS max at 70K feet
Dielectric Withstanding Voltage: 500 VRMS min at sea level
Insulation Resistance: 1000 Megohms min

Contact Resistance: (milliohms max)	Initial	After Environmental
Center Contact	3.0	4.0
Outer Conductor	2.0	NA

Corona Level: 125 Volts at 70K feet
Insertion Loss: (Dependant upon application)

RF Leakage: Not Applicable
RF High Potential Withstanding Voltage: 335 VRMS min at 4 and 7 MHz

Mechanical Specifications

Engagement Design: MIL-STD-348, Series SMA
Engagement/Disengagement Force: 2 lb-in max
Mating Torque: 7 to 10 lb-in
Contact Retention: 6 lbs min axial force, 4 oz-in min radial torque

Environmental Ratings

(Meets or Exceeds the Applicable Paragraph of MIL-PRF-39012)

Temperature Range: - 65°C to + 165°C
Thermal Shock: MIL-STD-202, Method 107, Condition B - Except 115°C High Temp
Corrosion: MIL-STD-202, Method 101, Condition B
Shock: MIL-STD-202, Method 213, Condition I
Vibration: MIL-STD-202, Method 204, Condition D
Moisture Resistance: MIL-STD-202, Method 106

Mating Engagement for SMA Series Thickwall Plug Compatible with MIL-STD-348

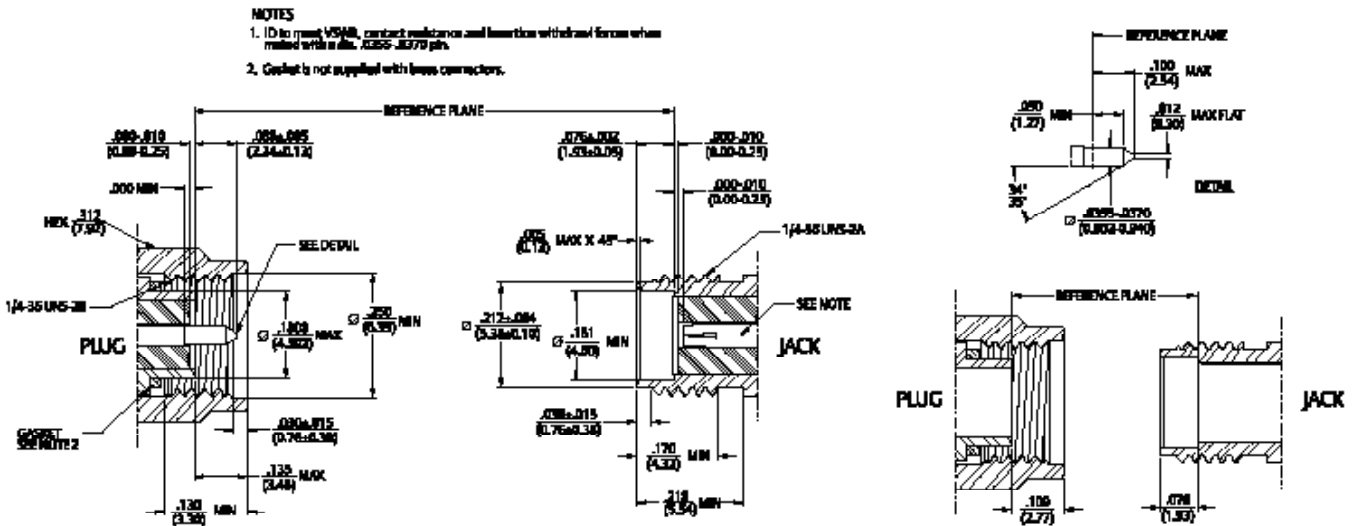

High Frequency SMA End Launch Connectors for Microwave PC Board Substrates

The Johnson line of High Frequency End Launch connectors are used to transition microwave energy from coaxial to planar transmission line structures. These connectors provide a unique solution for microwave engineers who fabricate circuit designs on very thin high frequency board substrates. The in-line connector design minimizes reflections as compared to a right-angle (perpendicular) pc mount transition.

- Cellular Linear Power Amplifiers
- Broadband MMIC Power Amplifiers
- Microwave Filters, Mixers and Combiners
- Wireless Infrastructure Antennas
- DBS Low-Noise Block Down Converters
- Remote Sensing and Metering
- Global Positioning Satellite Antennas
- Phased Array Antennas
- Radar Systems
- High Speed Routers and Switches
- Automated Test Equipment
- RF Identification Tags



COAXIAL

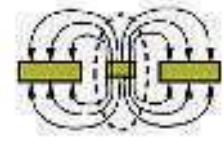

COPLANAR

High Frequency End Launch connectors are designed to attach directly to a high frequency coplanar waveguide (CPW) circuit board transmission line, although other lines such as microstrip can be used with good results. These connectors can be used on high frequency PC board substrate layers as thin as 8 mils, and operate at frequencies up to 26.5 GHz (see Return Loss chart).

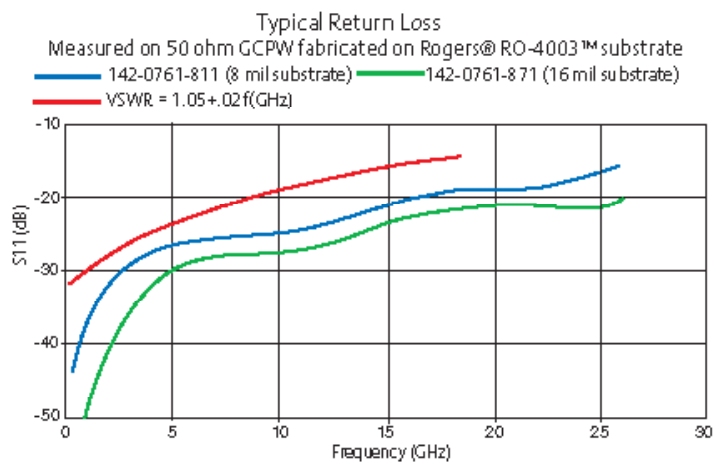

Design Features

This connector is an economical alternative to other high frequency designs in the industry. This design differentiates itself from other launch connectors:

- Design of the connector is self contained, no external mounting screws, adapter sections, spring clips, etc. are required for assembly to the circuit board.
- Center contact pin does not require special orientation to the surface of the circuit board. The center contact is mechanically captivated and optimized to maintain proper impedance while withstanding torque and axial force stress.
- Output coax of the connector at board launch is sized appropriately to match the thickness of the high frequency board substrate. The output coax section extends well within the connector while maintaining constant inner and outer coaxial diameters.
- Signal side grounding legs of the connector are spaced close enough to keep grounding paths short, but far enough apart to maintain constant impedance in the launch transition area.
- Signal side grounding legs and GCPW geometry control radiation, no additional shielding is required to prevent signal cross-talk effects in the transition area. The launch transition is effectively isolated from adjacent transmis-

sion lines in the signal plane.

- Connector is not locked into position when placed on the circuit board. Intentional floating design allows proper alignment in X, Y and Z, minimizing discontinuities due to manufacturing tolerances.
- The distinctive through hole mounting technique allows the use of one connector with varying circuit board thicknesses. The connectors are also available in a traditional straddle mount end launch design, which was pioneered by Cinch Connectivity Solutions over 30 years ago.
- A small amount of PTFE insulation projects from the rear mating plane of the connector, acting as a seal when soldering the center conductor pin to the trace. The connector is held against the circuit board edge during the soldering process, compressing the PTFE insulation. This effectively creates a barrier between the inner and outer conductors, preventing the bridging of solder.
- Appropriate sized connectors do not require additional compensation to standard coplanar or microstrip matched impedance line geometries. Transition can be fine-tuned by pulling the trace back a slight amount from the board edge.

For more information, please contact customer service at (507) 833-8822 or (800) 247-8256 • cinch.com

Illustrations are shown in inches (millimeters).

Specifications

Electrical Ratings

Impedance: 50 Ohms

Frequency Range:

Flexible cable connectors	0-12.4 GHz
Uncabled receptacles	0-18.0 GHz
Straight Semi-Rigid cable connectors.....	0-26.5 GHz

VSWR: (max) (f = GHz)

	Straight Cabled Connectors	Right Angle Cabled Connectors
RG-316, LMR-100 cable	1.15+.02f	1.15+.03f
RG-58, LMR-195 cable.....	1.15+.01f	1.15+.02f
RG-142 cable.....	1.15+.01f	1.15+.02f
RG-405 cable (0 - 18 GHz)	1.07+.008f	
RG-405 cable (18 - 26.5 GHz)	1.35 max	
RG-402 cable (w/contact)	1.05+.008f	
RG-402 cable (w/o contact)	1.035+.005f	

Insertion Loss: (dB max)

Straight flexible cable connectors	0.06 \sqrt{f} (GHz), tested at 6 GHz
Right angle flexible cable connectors.....	0.15 \sqrt{f} (GHz), tested at 6 GHz
Straight Semi-Rigid cable connectors with contact	0.03 \sqrt{f} (GHz), tested at 10 GHz
Straight Semi-Rigid cable connectors w/o contact.....	0.03 \sqrt{f} (GHz), tested at 16 GHz
Uncabled receptacles	N/A

Working Voltage: (VRMS max)

	Sea Level	70K Feet
RG-316, LMR-100, 195	250	65
RG-58, RG-142, RG-405, uncabled receptacles, RG-402 w/o contact.....	335	85
RG-402 with contact.....	500	125

Dielectric Withstanding Voltage: (VRMS min at sea level) †

	Sea Level
RG-316, LMR-100, 195	750
RG-58, RG-142, RG-405, uncabled receptacles	1000
RG-402 with contact.....	1500
RG-402 w/o contact.....	N/A

Corona Level: (Volts min at 70,000 feet)

	70K Feet
RG-316, LMR-100, 195	190
RG-58, RG-142, .086 Semi-Rigid, uncabled receptacles, RG-402 w/o contact.....	250
RG-402 with contact	375

Insulation Resistance: 5000 Megohms min

	Initial	After Environmental
Contact Resistance: (milliohms max)		
Center contact (straight cabled connectors and uncabled receptacles)	3.0*	4.0*
Center contact (right angle cabled connectors)	4.0	6.0
Outer contact (all connectors)	2.0	N/A
Braid to Body (gold plated bodies)	0.5	N/A

*N/A where the cable center conductor is used as a contact

RF Leakage: (dB min, tested at 2.5 GHz)

Flexible cable connectors and RG-402 connectors w/o contact	-60
RG-405 connectors and RG-402 connectors with contact	-90
Uncabled receptacles	N/A

RF High Potential Withstanding Voltage: (VRMS min, tested at 4 and 7 MHz)

RG-316, LMR-100, 195	500
RG-58, RG-142, RG-405,	
RG-402 cable w/o contact, Uncabled receptacles	670
RG-402 with contact	1000

† Avoid user injury due to misapplication. See safety advisory definitions.

Mechanical Specifications

Engagement Design:	MIL-STD-348, Series SMA
Durability:	500 cycles min 100 cycles min for RG-402 connectors w/o contact
Engagement/Disengagement Force:	2 inch-pounds max
Mating Torque:	7 to 10 lb-in
Bulkhead Mounting Nut Torque:	15 lb-ins recommended
Coupling Proof Torque:	15 lb-ins min
Coupling Nut Retention:	60-lbs min
Contact Retention:	6 lbs. min axial force (captivated contacts) 4 oz-in min torque (uncabled receptacles)

Cable Retention: (minimum *)

	<u>Axial Force (lbs)</u>	<u>Torque (oz-in)</u>
RG-316, LMR-100	20	N/A
RG-58.....	40	N/A
RG-142 Cabled	45	N/A
RG-405.....	30	16
RG-402	60	55
LMR-195.....	30	N/A

* Or cable breaking strength, whichever is less

Environmental Specifications

(Meets or Exceeds the Applicable Paragraph of MIL-PRF-39012)

Temperature Range:	-65°C to +165°C
Thermal Shock:	MIL-STD-202, Method 107, Condition B (except +85°C high temperature)
Corrosion:	MIL-STD-202, Method 101, Condition B
Shock:	MIL-STD-202, Method 213, Condition I
Vibration:	MIL-STD-202, Method 204, Condition D
Moisture Resistance:	MIL-STD-202, Method 106

Material Specifications

Bodies:	Stainless Steel, type 303, per ASTM A 582, passivated per MIL-DTL-14072 (EL 300), or gold Plated per MIL-G-45204 .00005" min
Contacts:	Male - Brass per ASTM B16, Gold plated* per MIL-G-45204 (.00005" min) Female – Beryllium Copper per ASTM B196, Gold plated* per MIL-G-45204 (.00005" min)
Insulators:	PTFE Fluorocarbon per ASTM D1710 and ASTM D1457
Gaskets:	Silicon Rubber per A-A-59588A
Expansion Caps:	Brass per ASTM B16, gold plated per MIL-G-45204 .00005" min or nickel plated per AMS-QQ-N-290
Crimp Sleeves:	Copper per ASTM A75, gold plated per MIL-G-45204 .0005"min or nickel per AMS-QQ-N-290 plated (.00005" min)
Nut Retention Spring (Plugs):	Beryllium Copper per ASTM B196, un-plated
Mounting Hardware:	Stainless Steel, type 303, Per ASTM A582, passivated per MIL-DTL-14072 (EL 300), or gold plated* per MIL-G-45204 .00005" min

Note: All Gold plated parts include a .00005" min Nickel under plated barrier layer.

For more information, please contact customer service at (507) 833-8822 or (800) 247-8256 • cinch.com

Illustrations are shown in inches (millimeters).

Straight Solder Type Plug – with Contact, Captive Nut Thin Wall

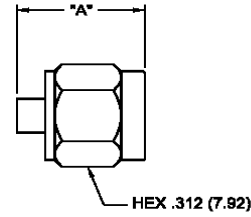

Cable Type	Gold Plated Body	"A"
RG-405	141-0693-002	.405
RG-402	141-0694-002	.440

Assembly instructions page 214.

Straight Solder Type Plug – Without Contact, Thread-On Nut

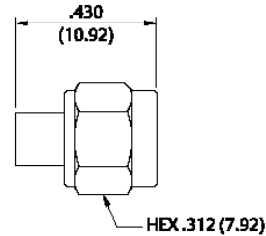

Cable Type	Gold Plated Body
RG-402	141-0694-012

Assembly instructions page 214.

Straight Solder Type Plug with Captivated Solderless Contact, Captive Nut and Thick Wall Interface

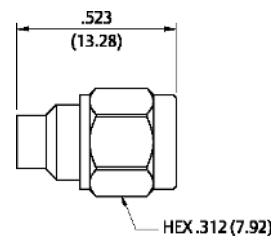

Cable Type	Gold Plated Body
RG-405	141-0693-062
RG-402	141-0694-062

Assembly instructions page 222.

Semi-Rigid

Straight Solder Type Jack



Cable Type	Gold Plated Body
RG-405	141-0593-001
RG-402	141-0594-001

Assembly instructions page 214.

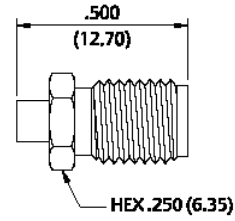

Straight Solder Type Bulkhead Jack with O-Ring



Cable Type	Gold Plated Body
RG-405	141-0593-401
RG-402	141-0594-401

Assembly instructions page 214.

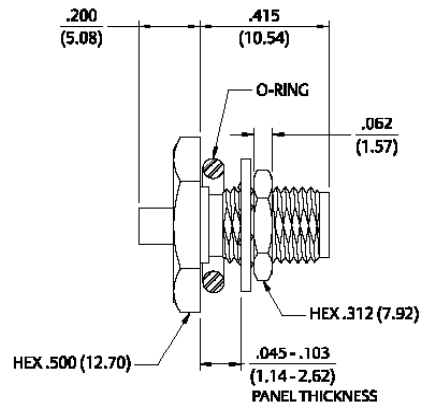

Straight Solder Type Bulkhead Jack with Captivated Solderless Contact and O-Ring



Cable Type	Gold Plated Body
RG-405	141-0593-421
RG-402	141-0594-421

Assembly instructions page 222.

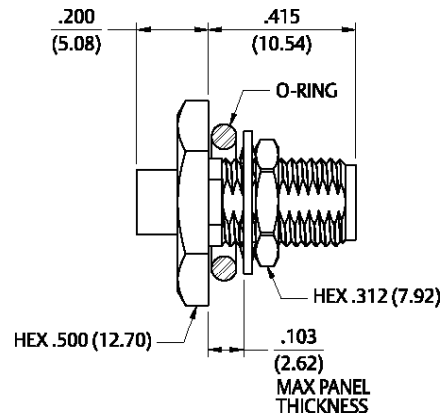

Straight Crimp Type Plug (3-piece) – Solder or Crimp Captivated Contact

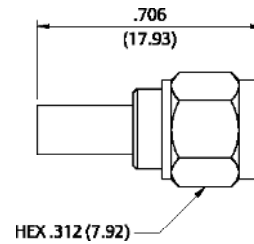

Cable Type	Passivated
RG-161, 174,188, 316, LMR-100, HPF-100, RF-100	141-0403-012
RG-188 DS, RG-316 DS	141-0404-012
RG-58, 141, 303, LMR-195, HPF-195, RF-195	141-0407-012
RG-55, 142, 223, 400	141-0408-012

Assembly instructions page 219.

Right Angle Crimp Type Plug – Captivated Contact

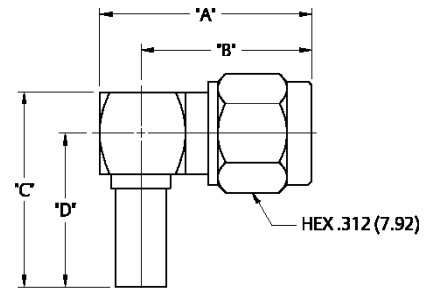

Cable Type	Passivated	"A"	"B"	"C"	"D"
RG-161, 174,188, 316	141-0403-102	.652	.527	.593	.467
RG-188 DS, RG-316 DS	141-0404-112	.652	.527	.593	.467
RG-58, 141, 303	141-0407-102	.636	.519	.596	.471
RG-55, 142, 223, 400	141-0408-102	.636	.519	.596	.471

Assembly instructions page 224.

Straight Crimp Type Bulkhead Jack (3-piece) – Solder or Crimp Captivated Contact

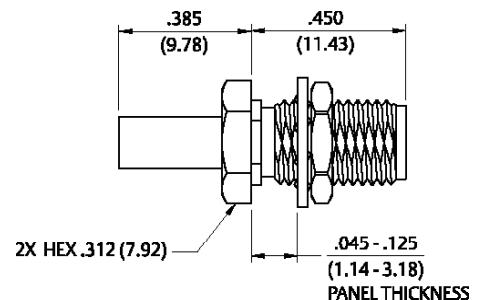

Cable Type	Passivated
RG-161, 174,188, 316	141-0303-412
RG-188 DS, RG-316 DS	141-0304-412
RG-58, 141, 303	141-0307-412
RG-55, 142, 223, 400	141-0308-412

Assembly instructions page 219.

For more information, please contact customer service at (507) 833-8822 or (800) 247-8256 • cinch.com

Illustrations are shown in inches (millimeters).

PC Mount, Bulkhead and Panel Mount

Right Angle PC Mount Jack Receptacle



Gold Plated
141-0701-301

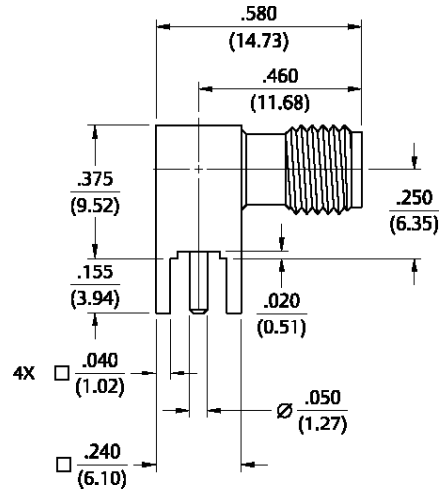

Straight PC Mount Jack Receptacle



Gold Plated
141-0701-201

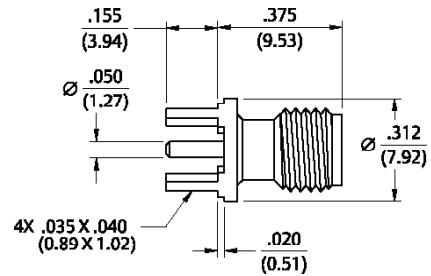

Rear Mount Bulkhead Jack Receptacle



Passivated
141-0701-402

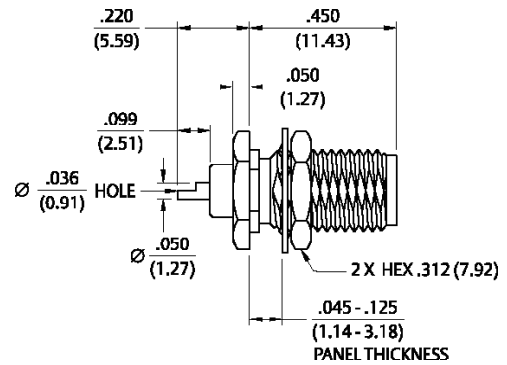

2-Hole Flange Mount Jack Receptacle – Flush Dielectric



Passivated
141-0701-602

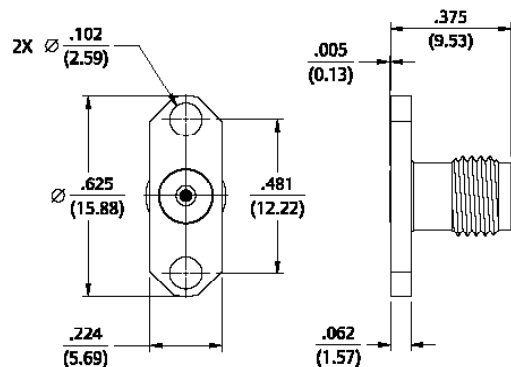

4-Hole Flange Mount Jack Receptacle – Flush Dielectric



Passivated

141-0701-612

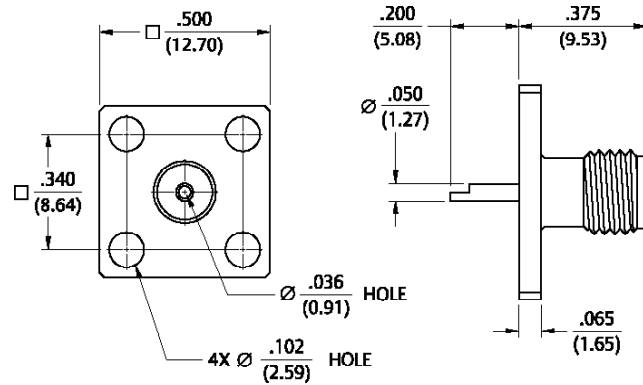

2-Hole Flange Mount Jack Receptacle – Extended Dielectric



Passivated

141-0701-622

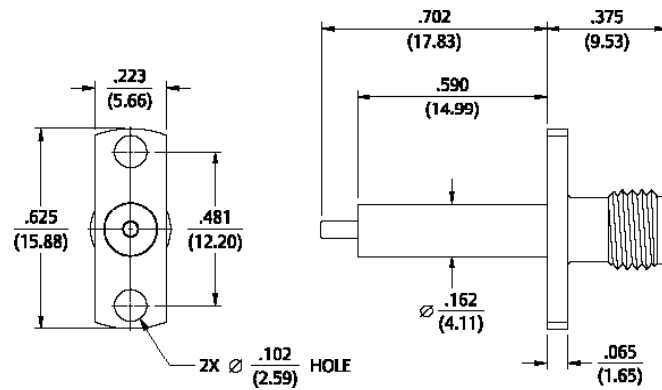

4-Hole Flange Mount Jack Receptacle – Extended Dielectric



Passivated

141-0701-632

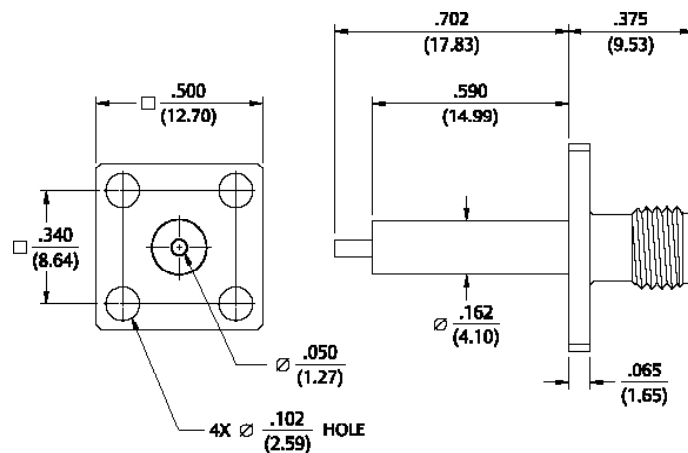

For more information, please contact customer service at (507) 833-8822 or (800) 247-8256 • cinch.com
 Illustrations are shown in inches (millimeters).

Specifications

Electrical Specifications

Impedance:	50 Ohms		
Frequency Range:	0-6 GHz		
Attenuation Values:	1, 2, 3, 6 and 10 dB Nominal*		
Attenuation Accuracy:			
dB*	0 - 4 GHz	4 - 6 GHz	
1-3	±0.3	±0.5	
4-6	±0.4	±0.5	
7-10	±0.5	±0.5	
VSWR Max:			
dB*	0 - 2.5 GHz	2.5 - 4 GHz	4 - 6 GHz
1-3	1.15 : 1	1.20 : 1	1.25 : 1
4-6	1.15 : 1	1.20 : 1	1.25 : 1
7-10	1.15 : 1	1.25 : 1	1.30 : 1
Average Input Power:	2 W Max @ +25°C Derated Linearly to 0.5W at +125°C		

*Other values available, please contact Factory

Mechanical Specifications

SMA Connectors: Per MIL-STD-348A

Environmental Specifications

Temperature Range:	-55°C to +125°C
Thermal Shock:	MIL-STD-202, Method 107, Condition B except +100°C high temperature)
Shock:	MIL-STD-202, Method 213, Condition I
Vibration:	MIL-STD-202, Method 204, Condition D

Material Specifications

Connector Body:	303 Stainless Steel per ASTM A582, Passivated per MIL-F-14-72 (EL 300)
Coupling Nut:	303 Stainless Steel per ASTM A582, Passivated per MIL-F-14-72 (EL 300)
Retaining Ring:	Beryllium Copper per ASTM B196, Unplated
SMA Plug Gasket:	Silicone Rubber per ZZ-R-765
Male Contact:	Brass per ASTM B16, Gold Plated per MIL-G-45204 (.00003 min)
Female Contact:	Beryllium Copper per ASTM B196, Gold Plated per MIL-G-45204 (.00003 min)
Insulators:	PTFE per ASTM D1710
Attenuator Card:	Alumina per Mil-I-10, RoHS Compliant Terminals

SMA Fixed Attenuators Commercial Series



Attenuation (dB Nominal)*	Freq. Range	Stainless Steel Passivated
1	(0-6 GHz)	141-3901-801
2	(0-6 GHz)	141-3901-802
3	(0-6 GHz)	141-3901-803
6	(0-6 GHz)	141-3901-806
10	(0-6 GHz)	141-3901-810

* Standard values shown. Contact factory for other requirements. Inches (millimeters).

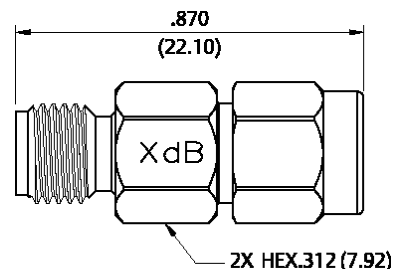

SMB Connectors

50 Ohm Connectors	
Specifications.....	104
Semi-Rigid & Flexible Cable	107
PC Mount.....	111
Bulkhead & Panel Mount.....	115
Adapters	116
Terminations	116
50 Ohm Non-Magnetic Connectors	
Specifications.....	117
Semi-Rigid & Flexible Cable	118
PC Mount.....	119
75 Ohm Connectors	
Specifications.....	120
Semi-Rigid & Flexible Cable	123
PC Mount.....	125
Panel Mount.....	127
Terminations	129
Adapters	130
Other Information	
Assembly Tools	185
Capabilities	190
Cable Information	192
Assembly Instruction	193
Mounting Hole Layouts	194
Numerical Index	274
Competitor Cross Reference	280

3	MMCX Connectors
13	MCX Connectors
39	SMK Connectors
45	SMA Connectors
103	SMB Connectors
131	SMC Connectors
137	SMP Connectors
145	Type N Connectors
153	Shielded Cable Terminations
157	Between-Series Adapters
161	Fixed Length Cable Assemblies
173	Ultra Miniature Connectors (UMC)
181	kwiQMate™ Connectors
185	Tools
193	Assembly Instructions
257	Electronic Hardware
274	Index

While every precaution has been taken to ensure accuracy and completeness herein, Cinch Connectivity Solutions assumes no responsibility, and disclaims all liability for damages resulting from use of this information or for any errors or omissions. Specifications subject to change without notice.

Specifications

Electrical Specifications

Impedance: 50 Ohms

Frequency Range:

Connectors	0-4 GHz
Dummy loads.....	0-1 GHz

VSWR: (max) (f = GHz)

	Straight <u>Cabled Connectors</u>	Right Angle <u>Cabled Connectors</u>
RG-178	1.30 + .04f	1.45 + .06f
RG-316, RG-58, and RG-405	1.25 + .04f	1.35 + .04f
Adapters	1.20 + .04f	
Uncabled receptacles, dummy loads.....		N/A

Working Voltage: (VRMS max)†

	<u>Sea Level</u>	<u>70K Feet</u>
RG-178.....	250	60
RG-316, RG-58, RG-405, uncabled receptacles, adapters	335	85
Dummy loads.....		N/A

Dielectric Withstanding Voltage: (VRMS min at sea level)

RG-316	750
RG-58, RG-142, uncabled receptacles	1000
Dummy loads.....	N/A

Corona Level: (Volts min at 70,000 feet)†

RG-178.....	185
RG-316, RG-58, RG-405.....	250
Uncabled receptacles, adapters, dummy loads.....	N/A

Insertion Loss: (dB max, tested at 1.5 GHz)

Straight cabled connectors	0.30 dB
Right angle cabled connectors.....	0.60 dB
Uncabled receptacles, adapters, dummy loads.....	N/A

Insulation Resistance: 1000 megohms min

Contact Resistance: (milliohms max)

	<u>Initial</u>	<u>After Environmental</u>
Center contact (straight cabled connectors and uncabled receptacles)	6.0	8.0
Center contact (right angle cabled connectors and adapters)	12.0	16.0
Outer contact (gold plated connectors)	1.0	1.5
Outer contact (nickel plated connectors)	2.5	3.5
Braid to body (gold plated connectors)	1.0	N/A
Braid to body (nickel plated connectors)	2.5	N/A

RF Leakage: (dB min, tested at 2.5 GHz)

Cabled connectors.....	-55 dB
Uncabled receptacles, adapters, dummy loads	N/A

RF High Potential Withstanding Voltage:

(VRMS min, tested at 4 and 7 MHz)†

RG-178.....	500
RG-316, RG-58	700
Uncabled receptacles and adapters	600
Dummy loads.....	N/A

Power Rating (Dummy Load): 0.5 watt @ +25°C, derated to 0.25 watt @ +125° C

Mechanical Specifications

Engagement Design: MIL-STD-348, Series SMB
Engagement/Disengagement Force: 2 lbs min to 14 lbs max axial force
Contact Retention: 4 lbs min axial force (captivated contacts)
 1 oz-in min torque (uncabled receptacles)

Cable Retention:	Axial Force* (lbs)	Torque (oz-in)
RG-178	10	N/A
RG-316	20	N/A
RG-58	40	N/A
RG-405	30	16

*Or cable breaking strength whichever is less.

Durability: 500 cycles min

Environmental Specifications

(Meets or Exceeds the Applicable Paragraph of MIL-PRF-39012)

Temperature Range: Connectors..... - 65°C to + 165°C
 Dummy loads..... - 65°C to + 125°C
Thermal Shock: MIL-STD-202, Method 107, Condition B (N/A dummy loads)
Corrosion: MIL-STD-202, Method 101, Condition B (N/A dummy loads)
Shock: MIL-STD-202, Method 213, Condition B (N/A dummy loads)
Vibration: MIL-STD-202, Method 204, Condition B (N/A dummy loads)

Material Specifications

Bodies: Brass per ASTM B16 or zinc per ASTM B86-71, gold plated per MIL-DTL-45204 .00001" min or nickel plated per SAE-AMS2423
Contacts: Male - brass per ASTM B16, gold plated per MIL-DTL-45204 .00003" min
 Female - beryllium copper per ASTM B196, gold plated per MIL-DTL-45204 .00003" min
Insulators: PTFE fluorocarbon per ASTM D 1710 and ASTM D 1457 or Teflon PFA 340
Expansion Caps: Brass per ASTM B36, gold plated per MIL-DTL-45204 .00001" min or nickel plated per SAE-AMS2423
Crimp Sleeves: Copper per ASTM B301 or brass per ASTM B16, gold plated per MIL-DTL-45204 .00001" min or nickel plated per SAE-AMS2423
Mounting Hardware: Brass (nuts) per ASTM B16 or phosphor bronze (lockwashers) per ASTM B139, gold plated per MIL-DTL-45204 .00001" min or nickel plated per SAE-AMS2423
Cover Rings: Phosphor Bronze per ASTM B139, gold plated per MIL-DTL-45204 .00001 min or nickel plated per SAE-AMS2423

† Avoid user injury due to misapplication. See safety advisory definitions inside front cover.

Note: All Gold plated parts include a .00005" min Nickel under plated barrier layer.

Specifications

Mating Engagement for SMB Series

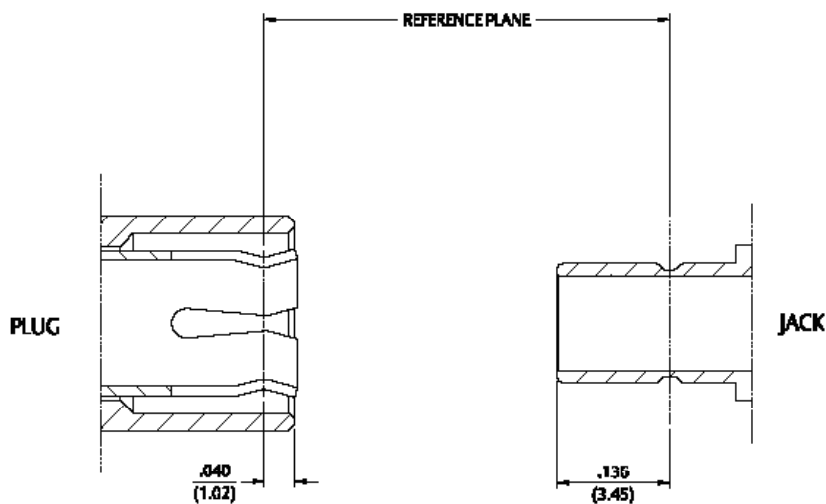
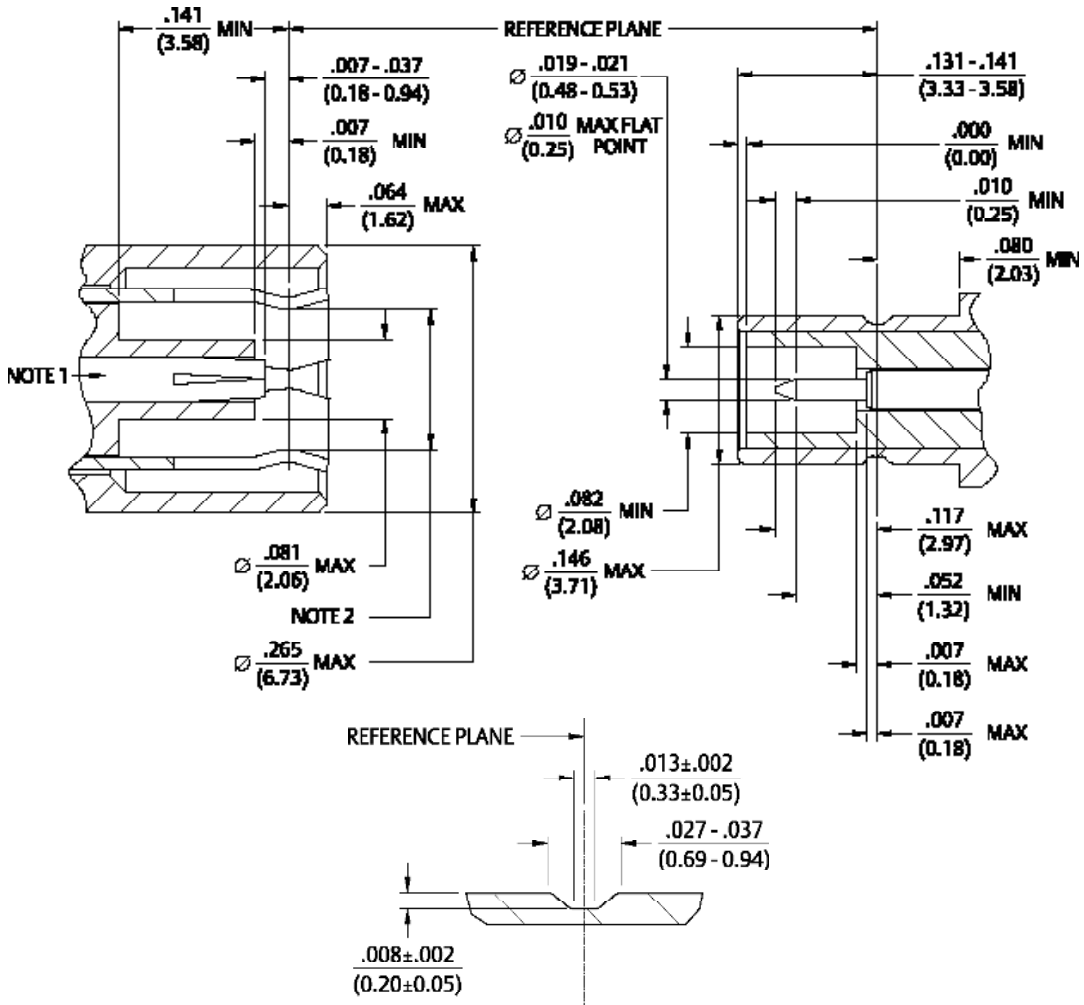

- Notes
1. ID of contact to meet VSWR, mating characteristics and connector durability when mated with a dia .019/.021 (0.48/0.53) male contact.
 2. Must meet the force to engage and disengage when mated with mating part.

Straight Solder Type Plug – Captivated Contact

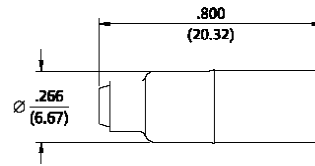

Cable Type	Gold Plated	Nickel Plated
RG-405	131-3693-001	131-3693-016

Assembly instructions page 233.

Straight Solder Type Bulkhead Plug – Captivated Contact

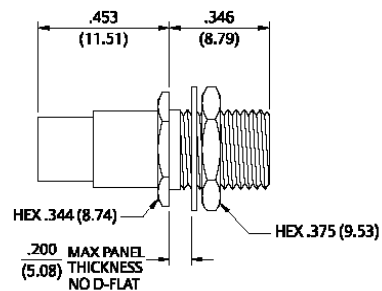

Cable Type	Gold Plated	Nickel Plated
RG-402	131-3694-401	131-3694-406

Assembly instructions page 233.
Mounting hole dia. .290 (7.05).

Right Angle Solder Type Plug – Captivated Contact

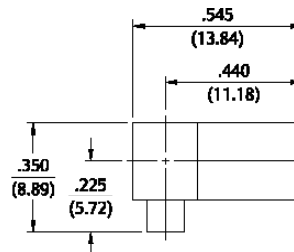

Cable Type	Gold Plated	Nickel Plated
RG-405	131-3693-101	131-3693-116

Assembly instructions page 234.

Straight Bulkhead Solder Type Jack – Captivated Contact

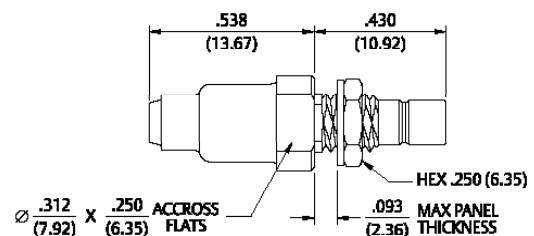

Cable Type	Gold Plated	Nickel Plated
RG-405	131-3593-401	131-3593-406

Assembly instructions page 233.
Mounting hole layout figure 5 page 194.

Flexible Cable

Straight Crimp Type Plug (3-Piece) – Solder or Crimp Captivated Contact

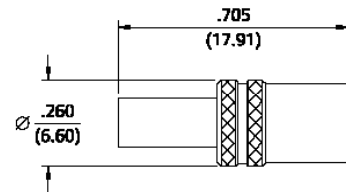

Cable Type	Gold Plated	Nickel Plated
RG-161, 174, 179, 187, 188, 316	131-3403-021	131-3403-026
RG-316 DS, 188 DS, 179 DS, 187 DS	131-3404-021	131-3404-026
RG-58, 141, 303	131-3407-011	131-3407-016

Assembly instructions page 232.

Straight Solder Type Bulkhead Plug – Solder or Crimp Captivated Contact

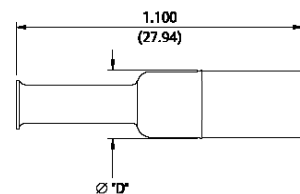

Cable Type	Gold Plated	Nickel Plated	Crimp Contact	“D”
RG-178, 196	131-3402-001	131-3402-016	No	.266 (6.76)
RG-161, 174, 179, 187, 188, 316	131-3403-001	131-3403-016	Yes	.266 (6.76)
RG-316 DS, 188 DS, 179 DS, 187 DS	131-3404-001	131-3404-016	Yes	.266 (6.76)
RG-58, 141, 303	131-3407-001	131-3407-006	Yes	.270 (6.86)

Assembly instructions page 237.

Straight Crimp Type Plug – Die Cast – Solder or Crimp Captivated Contact

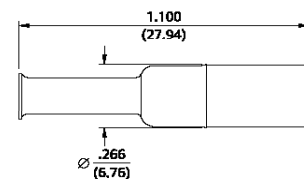

Cable Type	Gold Plated	Nickel Plated
RG-161, 174, 179, 187, 188, 316	131-1403-001	131-1403-016
RG-316 DS, 188 DS, 179 DS, 187 DS	131-1404-001	131-1404-016

Assembly instructions page 237.

Straight Crimp Type Bulkhead Plug – Solder or Crimp Captivated Contact

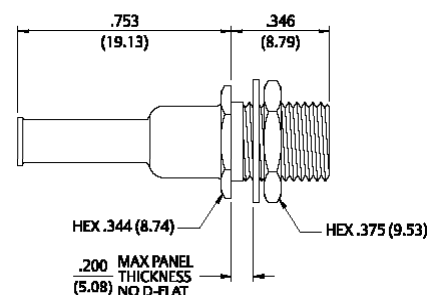

Cable Type	Gold Plated	Nickel Plated
RG-161U, 174, 179, 187, 188, 316	131-3403-401	131-3403-406
RG-316 DS, 188 DS, 179 DS, 187 DS	131-3404-401	131-3404-406

Assembly instructions page 237. Mounting hole dia. .290 (7.05).

Right Angle Crimp Type Plug – Captivated Contact



Cable Type	Gold Plated	Nickel Plated
RG-178, 196	131-3402-101	131-3402-116
RG-161, 174, 179, 187, 188, 316	131-3403-101	131-3403-116
RG-316 DS, 188 DS, 179 DS, 187 DS	131-3404-101	131-3404-116

Assembly instructions page 238.

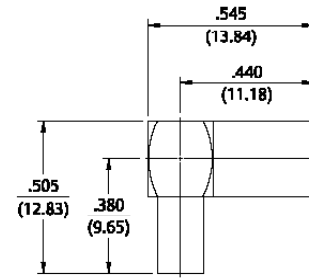

Right Angle Crimp Type Plug – Captivated Contact



Cable Type	Gold Plated	Nickel Plated
RG-58, 141, 303	131-3407-101	131-3407-106

Assembly instructions page 238.

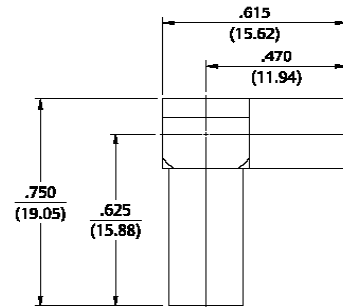

Right Angle Crimp Type Plug – Die Cast – Captivated Contact



Cable Type	Gold Plated	Nickel Plated
RG-178, 196	131-1402-101	131-1402-116
RG-161, 174, 179, 187, 188, 316	131-1403-101	131-1403-116
RG-316 DS, 188 DS, 179 DS, 187 DS	131-1404-101	131-1404-116

Assembly instructions page 238.

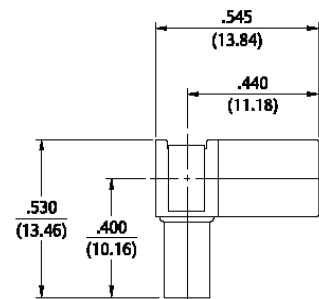

For more information, please contact customer service at (507) 833-8822 or (800) 247-8256 • cinch.com

Illustrations are shown in inches (millimeters).

Flexible Cable

Straight Crimp Type Jack – Solder or Crimp Captivated Contact

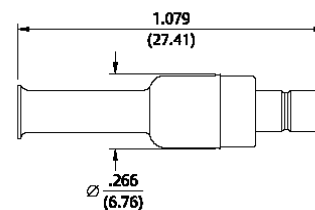

Cable Type	Gold Plated	Nickel Plated	Crimp Contact
RG-178, 196	131-3302-001	131-3302-006	No
RG-161, 174, 179, 187, 188, 316	131-3303-001	131-3303-006	Yes

Assembly instructions page 237.

Mounting hole layout figure 5 page 194.

Straight Crimp Type Bulkhead Jack – Solder or Crimp Captivated Contact

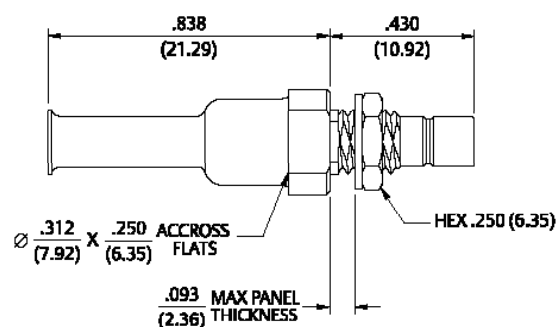

Cable Type	Gold Plated	Nickel Plated
RG-161, 174, 179, 187, 188, 316	131-3303-401	131-3303-406
RG-316 DS, 188 DS, 179 DS, 187 DS	131-3304-401	131-3304-406

Assembly instructions page 237.

Mounting hole layout figure 5 page 194.

Right Angle Crimp Type Bulkhead Jack – Captivated Contact

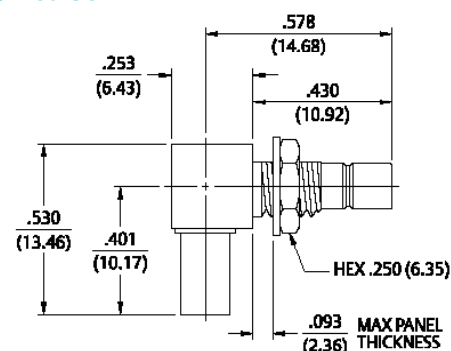

Cable Type	Gold Plated	Nickel Plated
RG-161, 174, 179, 187, 188, 316	131-3303-501	131-3303-506
RG-316 DS, 188 DS, 179 DS, 187 DS	131-3304-501	131-3304-506

Assembly instructions page 238.

Mounting hole layout figure 5 page 194.

Straight Plug Receptacle



Gold Plated	Nickel Plated	"A"
131-3801-201	131-3801-216	.395 (10.03)
131-3801-231	131-3801-236	.500 (12.70)

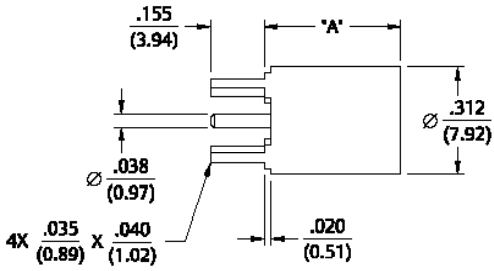

Mounting hole layout figure 4 page 194.

Right Angle Plug Receptacle



Gold Plated	Nickel Plated
131-3801-301	131-3801-316

Mounting hole layout figure 4 page 194.

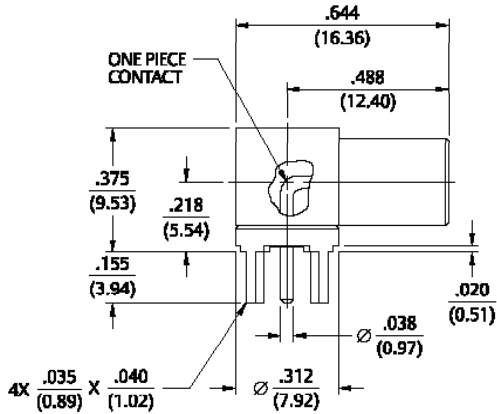

Right Angle Plug Receptacle – Die Cast



Gold Plated	Nickel Plated
131-1801-371	131-1801-376

Mounting hole layout figure 4 page 194.

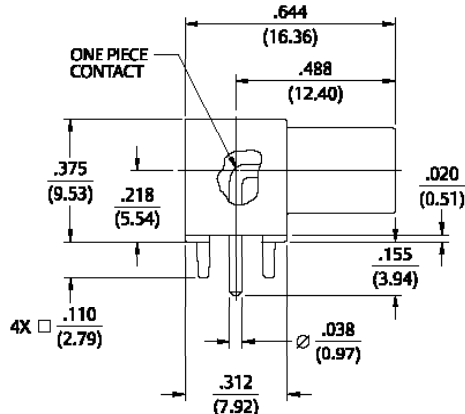

For more information, please contact customer service at (507) 833-8822 or (800) 247-8256 • cinch.com
 Illustrations are shown in inches (millimeters).

PC Mount

Straight Jack Receptacle



Gold Plated	Nickel Plated	"A"
131-3701-201	131-3701-206	.155 (3.94)
131-3701-211	131-3701-216	.110 (2.79)

Mounting hole layout figure 4 page 194.

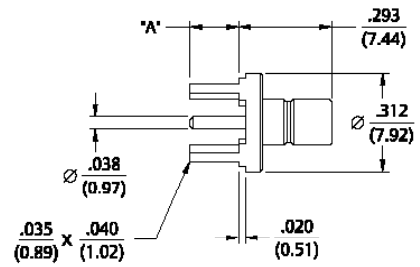

Straight Jack Receptacle



Gold Plated	Nickel Plated	"A"
131-3701-261	131-3701-266	.155 (3.94)
131-3701-271	131-3701-276	.095 (2.41)

Mounting hole layout figure 4 page 194.

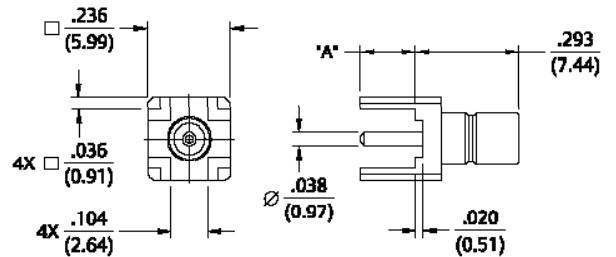

Straight Bulkhead Jack Receptacle



Gold Plated	Nickel Plated
131-3701-231	131-3701-236

Mounting hole layout figures 4 and 5 page 195.

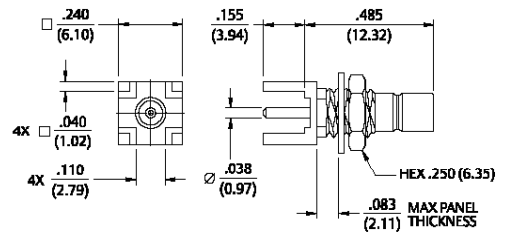

Straight Jack Receptacle – Surface Mount



Gold Plated
131-3711-201

Recommended Land pattern figure 9 page 194.

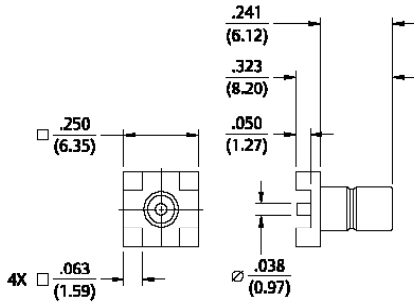

Right Angle Jack Receptacle



Gold Plated	Nickel Plated
131-3701-301	131-3701-306

Mounting hole layout figure 4 page 194.

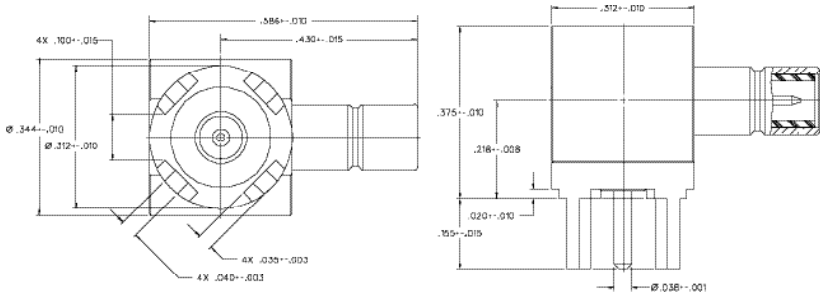

Right Angle Jack Receptacle – Die Cast



Gold Plated	Nickel Plated
131-1701-371	131-1701-376

Mounting hole layout figure 4 page 194.

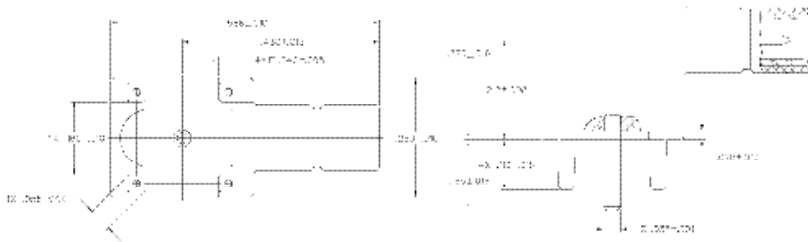

For more information, please contact customer service at (507) 833-8822 or (800) 247-8256 • cinch.com
Illustrations are shown in inches (millimeters).

PC Mount

Right Angle Surface Mount Jack Receptacle



Gold Plated	Packaging
131-3711-301	Stock
131-3711-302	Tape and Reel, 425 pcs/reel

Mounting hole layout figure 9 page 194.
Tape and Reel .630 (16.0) component pitch .945 (24.0) wide

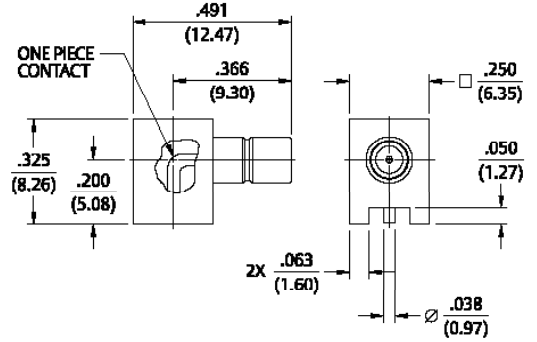

Right Angle Bulkhead Jack Receptacle



Gold Plated	Nickel Plated	"A"
131-3701-501	131-3701-506	.083 (2.11)
131-3701-511	131-3701-516	.110 (2.79)
131-3701-341	131-3701-346	.155 (3.94)

Mounting hole layout figures 4 and 5 page 194.

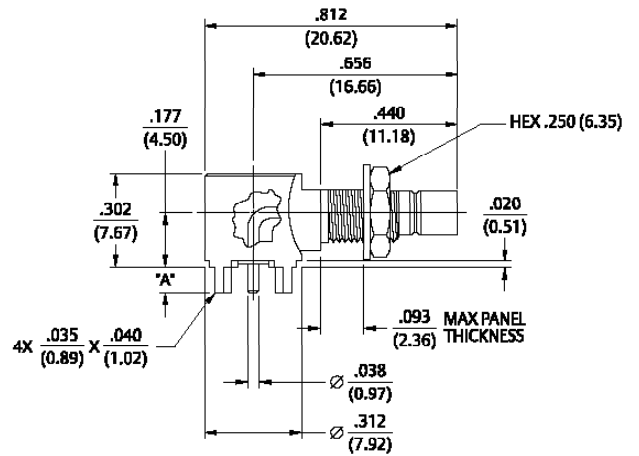

End Launch Jack Receptacle – Round Contact



Gold Plated	Nickel Plated	Board Thickness	"A"	"B"
131-3701-801	131-3701-806	.062 (1.57)	.068 (1.73)	.073 (1.85)
131-3701-821	131-3701-826	.042 (1.07)	.048 (1.22)	.093 (2.36)

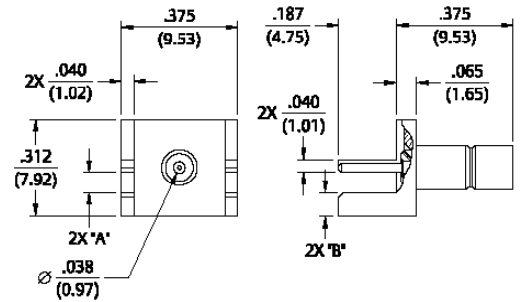

End Launch Jack Receptacle – Tab Contact



Gold Plated	Nickel Plated	Board Thickness	"A"	"B"
131-3701-811	131-3701-816	.062 (1.57)	.068 (1.73)	.083 (2.11)
131-3701-831	131-3701-836	.042 (1.07)	.048 (1.22)	.103 (2.62)

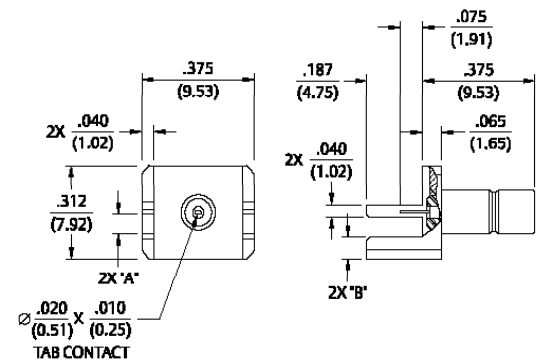

Front Mount Bulkhead Jack Receptacle

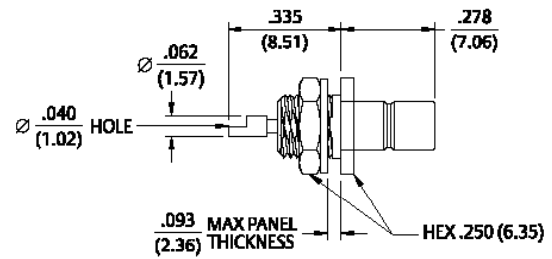

Gold Plated	Nickel Plated
131-3701-411	131-3701-416

Mounting hole layout figure 5 page 194.

Rear Mount Bulkhead Jack Receptacle

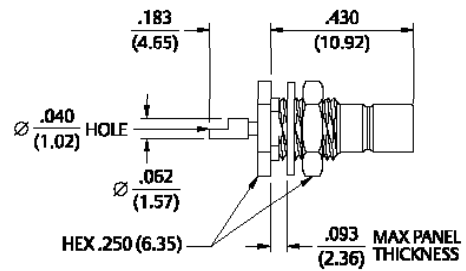

Gold Plated	Nickel Plated
131-3701-401	131-3701-406

Mounting hole layout figure 5 page 194.

Front Mount Bulkhead Jack Receptacle – Thread Mount Ruggedized Interface – Round Contact

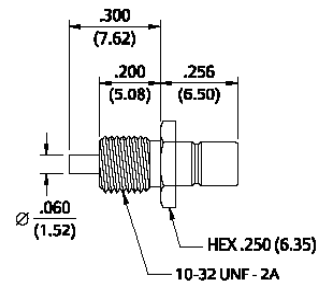

Gold Plated	Nickel Plated
131-3701-441	131-3701-446

2-Hole Flange Mount Jack Receptacle

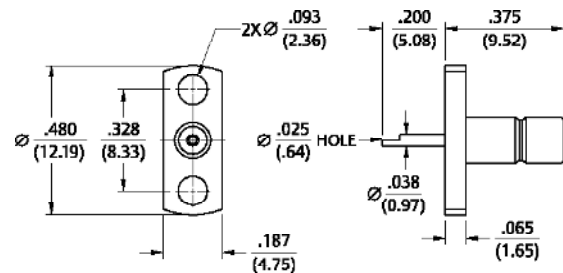

Gold Plated	Nickel Plated
131-3701-621	131-3701-626

4-Hole Flange Mount Jack Receptacle

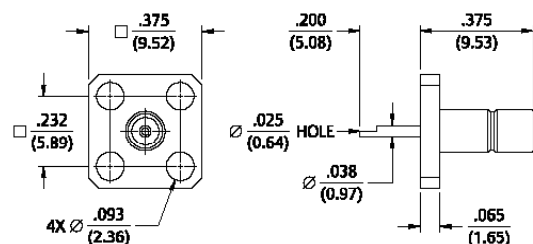

Gold Plated	Nickel Plated
131-3701-631	131-3701-636

For more information, please contact customer service at (507) 833-8822 or (800) 247-8256 • cinch.com

Illustrations are shown in inches (millimeters).

In-Series Adapters & Terminations

Jack to Bulkhead Jack Adapter



Gold Plated	Nickel Plated
131-3901-401	131-3901-406

Mounting hole layout figure 5 page 194.

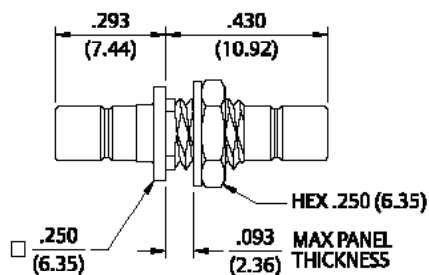

Plug to Bulkhead Jack Adapter



Gold Plated	Nickel Plated
131-3901-411	131-3901-416

Mounting hole layout figure 5 page 194.

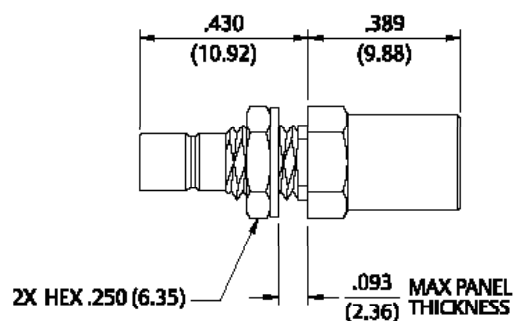

Plug Dummy Load – 50 Ohm and 75 Ohm



Gold Plated	Nickel Plated	Resistance
131-3801-811	131-3801-816	50 Ohm
131-3801-821	131-3801-826	75 Ohm

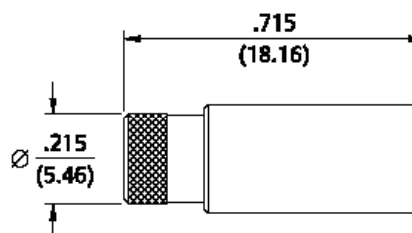

Electrical Specifications

Impedance: 50 Ohms

Frequency Range:

Connectors..... 0-4 GHz

VSWR: (max) (f = GHz)

	Straight Cabled Connectors	Right Angle Cabled Connectors
RG-316.....	1.25 + .04f	1.35 + .04f
Uncabled receptacles.....	N/A	

Working Voltage: (VRMS max)†

	Sea Level	70K Feet
RG-316, uncabled connectors.....	335	85

Dielectric Withstanding Voltage: (VRMS min at sea level)†

RG-316, uncabled receptacles..... 1000

Corona Level: (Volts min at 70,000 feet)†

RG-316..... 250

Uncabled receptacles..... N/A

Insertion Loss: (dB max, tested at 1.5 GHz)

Straight cabled connectors..... 0.30 dB

Right angle cabled connectors..... 0.60 dB

Uncabled receptacles..... N/A

Insulation Resistance: 1000 megohms min

Contact Resistance: (milliohms max)

	Initial	After Environmental
Center contact (straight cabled connectors and uncabled receptacles)	6.0	8.0
Center contact (right angle cabled connectors)	12.0	16.0
Outer contact	1.0	1.5
Braid to body	1.0	N/A

RF Leakage: (dB min tested at 2.5 GHz)

Cabled connectors..... -55 dB

Uncabled receptacles..... N/A

RF High Potential Withstanding Voltage: (Vrms min, tested at 4 and 7 MHz)†

Connectors for RG-316..... 700

Uncabled receptacles..... 600

Mechanical Specifications

Engagement Design: MIL-STD-348, Series SMB

Engagement/Disengagement Force: 2 pounds min to 14 pounds max axial force

Contact Retention: 4 lbs. min axial force (captivated contacts)

1 inch-ounce min torque (uncabled receptacles)

Cable Retention:

	Axial Force* (lbs)	Torque (oz-in)
RG-316.....	20	N/A

*or cable breaking strength whichever is less.

Durability: 500 cycles min

Environmental Specifications

(Meets or Exceeds the Applicable Paragraph of MIL-PRF-39012)

Temperature Range: - 65°C to + 165°C

Thermal Shock: MIL-STD-202, Method 107, Condition B

Corrosion: MIL-STD-202, Method 101, Condition B

Shock: MIL-STD-202, Method 213, Condition B

Vibration: MIL-STD-202, Method 204, Condition B

* See Non-Magnetic materials specifications page X.

† Avoid user injury due to misapplication. See safety advisory definitions inside front cover.

Refer back to Page 121 for Mating Engagement detail.

Material Specifications

(See non-magnetic materials page 10)

For more information, please contact customer service at (507) 833-8822 or (800) 247-8256 • cinch.com

Illustrations are shown in inches (millimeters).

Flexible Cable

Straight Crimp Type Plug – Solder or Crimp Captivated Contact

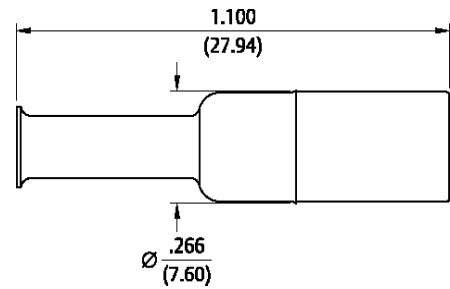

Cable Type	Gold Plated
RG-316, 188, 174, 179, 187	131-9403-001
RG-316 DS, 188 DS, 179 DS, 187 DS	131-9404-001

Assembly instructions page 235.

Straight Crimp Type Plug (3-piece) Solder or Crimp Captivated Contact

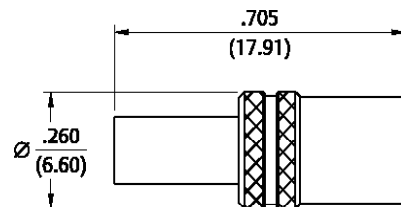

Cable Type	Gold Plated
RG-316, 188, 174, 179, 187	131-9403-021
RG-316 DS, 188 DS, 179 DS, 187 DS	131-9404-021

Assembly instructions page 232.

Right Angle Crimp Type Plug – Captivated Contact

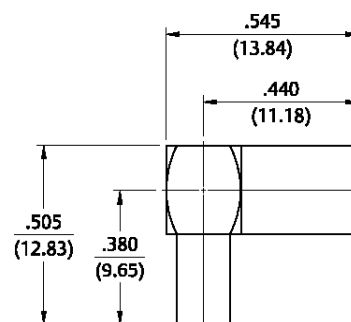

Cable Type	Gold Plated
RG-316, 188, 174, 179, 187	131-9403-101
RG-316 DS, 188 DS, 179 DS, 187 DS	131-9404-101

Assembly instructions page 236.

Straight Jack Receptacle

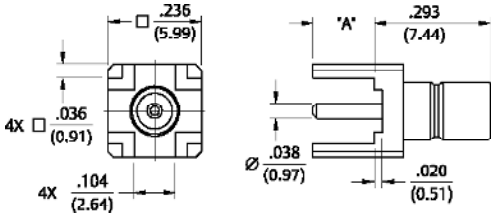

Gold Plated	"A"
131-9701-201	.155 (3.94)
131-9701-211	.095 (2.41)

Mounting hole layout figure 4 page 194.

Right Angle Jack Receptacle

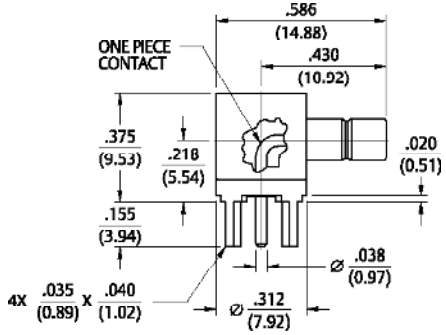

Gold Plated
131-9701-301

Mounting hole layout figure 4 page 194.

Specifications

Electrical Specifications

Impedance: 75 Ohms

Frequency Range: 0-2 GHz

VSWR: (max) (f = GHz)

RG-179, RG-59, Belden 735A:

Straight cabled connectors.....	1.25 + .04f
Right angle cabled connectors.....	1.35 + .04f
Adapters.....	1.20 + .04f
Type N Adapters.....	1.05 + .01f
Precision loads.....	1.05 + .01f
Uncabled receptacles, opens, shorts.....	N/A

Working Voltage: (VRMS max)

	Sea Level	70K Feet
RG-179, RG-59, Belden 735A, uncabled receptacles, adapters.....	335	85
Open, shorts, loads.....	N/A	N/A

Dielectric Withstanding Voltage: (Vrms min at sea level)†

RG-179, RG-59, Belden 735A, uncabled receptacles, adapters.....	1000
Open, shorts, loads.....	N/A

Insulation Resistance: 1000 megohms min

Contact Resistance: (milliohms max)

	Initial	After Environmental
Center contact (straight cabled connectors, uncabled receptacles, opens, shorts, loads).....	6.0	8.0
Center contact (right angle cabled connectors and adapters).....	12.0	16.0
Outer contact (gold plated connectors).....	1.0	1.5
Outer contact (nickel plated connectors).....	2.5	3.5
Braid to body (gold plated connectors).....	1.0	N/A

Corona Level: (Volts min at 70,000 ft)†

RG-179, RG-59, Belden 735A.....	250
Uncabled receptacles, adapters, open, shorts, loads.....	N/A

Insertion Loss: (dB max, tested at 1.5 GHz)

Straight cabled connectors.....	0.30 dB
Right angle cabled connectors.....	0.60 dB
Uncabled receptacles, adapters, opens, shorts, loads.....	N/A

RF Leakage: (dB min tested at 2.0 GHz)

Cabled connectors.....	-55 dB
Uncabled receptacles, adapters opens, shorts, loads.....	N/A

RF High Potential Withstanding Voltage:

(VRMS min, tested at 4 and 7 MHz)†

RG-179, RG-59, Belden 735A.....	700
Uncabled receptacles and adapters.....	600
Opens, shorts, loads.....	N/A

Power Rating: (Loads) 1.0 watt at +25°C derated linearly to .5 watt at +125°C

Electrical Length: Open $\pm 1.5^\circ$ ($\pm 5.2^\circ$ relative to short)

Short $\pm 1.5^\circ$ ($\pm 5.2^\circ$ relative to open)

Adapters $\pm 5.2^\circ$ (N/A for Jack-Bulkhead Jack and N Types)

Mechanical Specifications

- Engagement Design: Compatible with MIL-STD-348, Series SMB
Engagement/Disengagement Force: 2 lbs min to 14 lbs max axial force
Contact Retention: 4 lbs. min axial force (captivated contacts)
1 oz-in min torque (uncabled receptacles)

Table with 3 columns: Cable Retention, Axial Force* (lbs), and Torque (oz-in). Rows include RG-179, Belden 735A and RG-59.

* or cable breaking strength whichever is less.
Durability: 500 cycles min

Environmental Specifications

(Meets or Exceeds the Applicable Paragraph of MIL-PRF-39012)

- Temperature Range: - 65°C to +165°C - Connectors and adapters, - 65°C to +125°C - Loads, 20°C to 26°C -- Opens, shorts
Thermal Shock: MIL-STD-202, Method 107, Condition B (N/A opens, shorts, loads)
Corrosion: MIL-STD-202, Method 101, Condition B (N/A opens, shorts, loads)
Shock: MIL-STD-202, Method 213, Condition B (N/A opens, shorts, loads)
Vibration: MIL-STD-202, Method 204, Condition B (N/A opens, shorts, loads)
Temperature Coefficient: (Loads only) ± 300 ppm/°C

Material Specifications

- Bodies: Brass per ASTM B16, gold plated*** per MIL-DTL-45204 .00001" min or nickel plated per SAE-AMS2423 N type adapters stainless steel per SAE-AMS QQ-S-763, passivated per MIL-DTL-14072
Contacts: Male & Female - beryllium copper per ASTM B196, gold plated per MIL-DTL-45204 .00003" min
Insulators: PTFE fluorocarbon per ASTM D 1710 and ASTM D 1457
Expansion Caps: Brass per ASTM B36, gold plated per MIL-DTL-45204 .00001" min or nickel plated per SAE-AMS2423
Crimp Sleeves: Copper per ASTM B301, gold plated per MIL-DTL-45204 .00001" min or nickel plated per SAE-AMS2423
Mounting Hardware: Brass (nuts) per ASTM B16 or phosphor bronze (lockwashers) per ASTM B139, gold plated per MIL-DTL-45204 .00001" min or nickel plated per SAE-AMS2423

Note: All gold plated parts include a .00005" min nickel underplate barrier layer.
† Avoid user injury due to misapplication. See safety advisory definitions inside front cover.

Specifications

Mating Engagement for Mini-75 Ohm SMB Series (Intermutable with Standard 50 Ohm SMB)

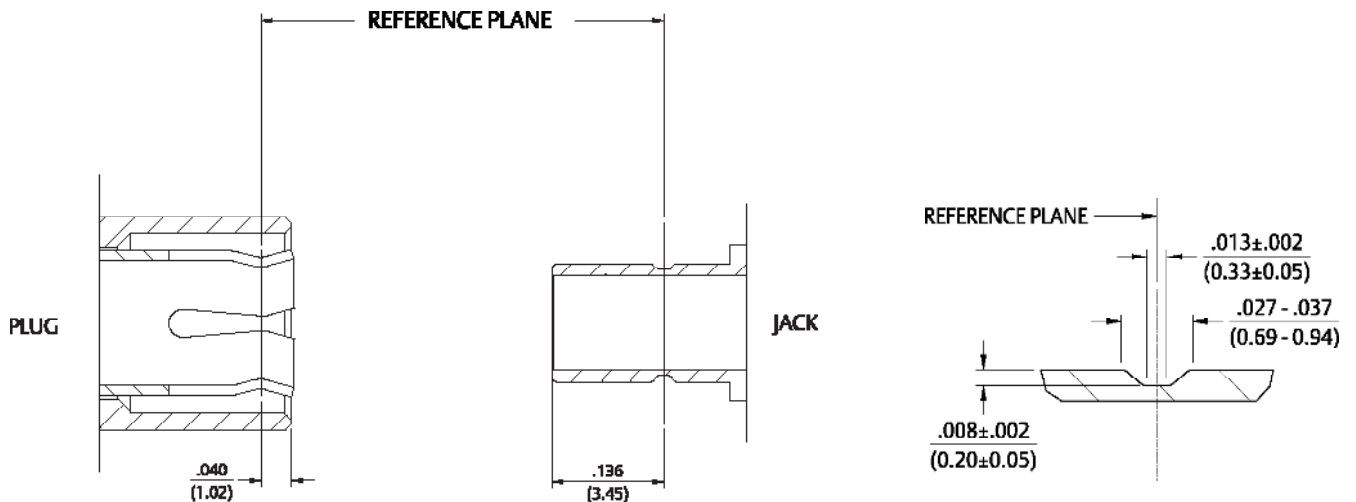
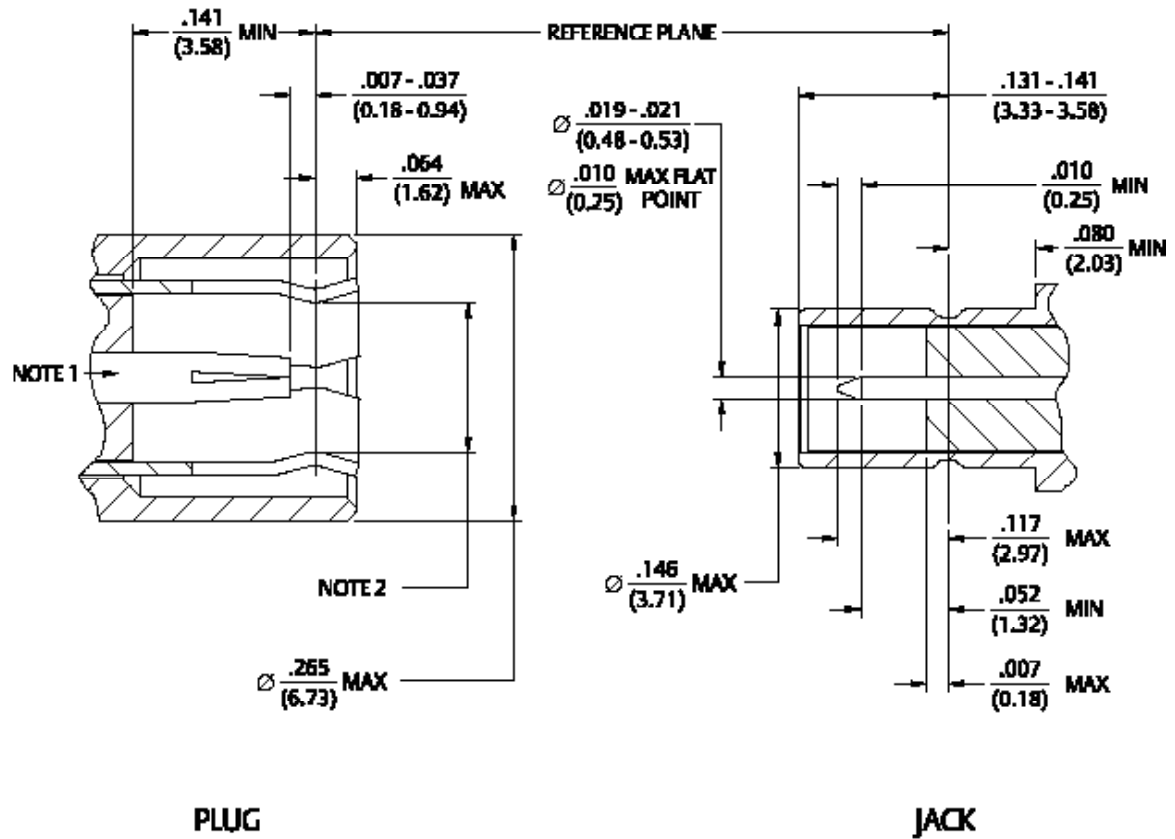

- Notes
1. ID of contact to meet VSWR, mating characteristics and connector durability when mated with a dia .019/.021 (0.48/0.53) male contact.
 2. Must meet the force to engage and disengage when mated with mating part.

Straight Crimp Type Plug (3-piece) – Solder or Crimp Captivated Contact

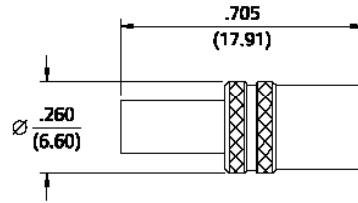

Cable Type	Gold Plated	Nickel Plated
RG-179, RG-187	131-8433-001	131-8433-006
RG-179 DS, RG-187 DS	131-8434-001	131-8434-006
Belden 735A	131-8445-011	131-8445-016

Assembly instructions page 232.

Straight Crimp Type Plug – Solder or Crimp Captivated Contact

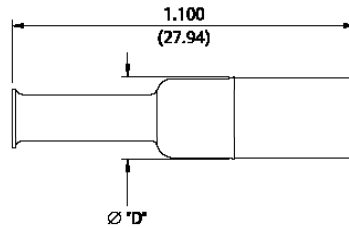

Cable Type	Gold Plated	Nickel Plated	"D"
RG-179, 187	131-8403-001	131-8403-006	.266 (6.76)
RG-179 DS, RG-187 DS	131-8404-001	131-8404-006	.266 (6.76)
Belden 735A	131-8445-001	131-8445-006	.266 (6.76)
RG-59	131-8409-001	131-8409-006	.312 (7.92)

Assembly instructions page 237.

Straight Crimp Type Plug – Die Cast – Solder or Crimp Captivated Contact

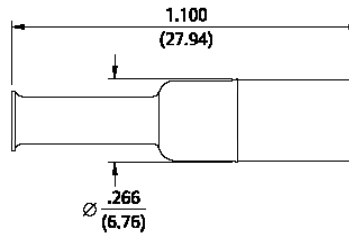

Cable Type	Gold Plated	Nickel Plated
RG-179, 187	131-8403-011	131-8403-016
RG-179 DS, RG-187 DS	131-8404-011	131-8404-016

Assembly instructions page 237.

Straight Crimp Type Bulkhead Jack – Solder or Crimp Captivated Contact

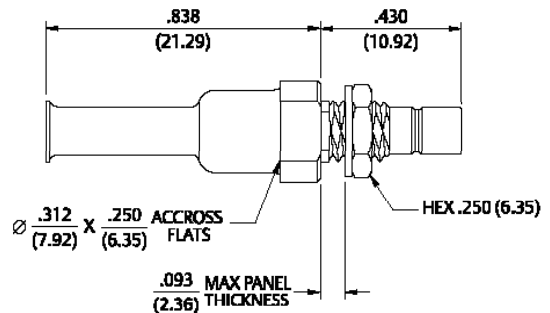

Cable Type	Gold Plated	Nickel Plated
RG-179, 187	131-8303-401	131-8303-406
RG-179 DS, RG-187 DS	131-8304-401	131-8304-406

Assembly instructions page 237.

For more information, please contact customer service at (507) 833-8822 or (800) 247-8256 • cinch.com

Illustrations are shown in inches (millimeters).

Flexible Cable

Right Angle Crimp Type Plug – Captivated Contact



Cable Type	Gold Plated	Nickel Plated	"A"	"B"
RG-179, 187	131-8403-101	131-8403-106	.505 (12.83)	.380 (9.65)
RG-179 DS, RG-187 DS	131-8404-101	131-8404-106	.505 (12.83)	.380 (9.65)
Belden 735A	131-8445-101	131-8445-106	.750 (19.05)	.625 (15.88)

Assembly instructions page 238.

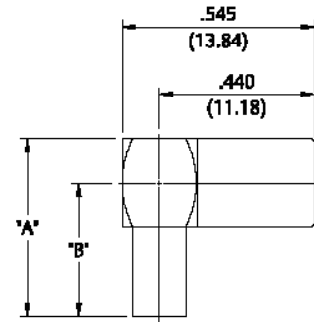

Right Angle Crimp Type Plug – Captivated Contact



Cable Type	Gold Plated	Nickel Plated
RG-59	131-8409-101	131-8409-106

Assembly instructions page 238.

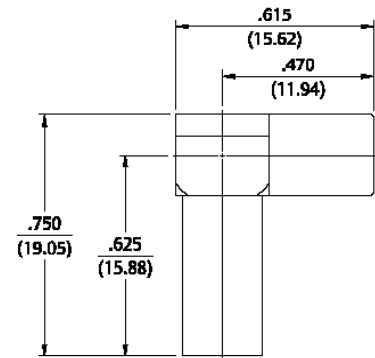

Right Angle Crimp Type Plug – Captivated Contact – Die Cast



Cable Type	Gold Plated	Nickel Plated
RG-179, 187	131-8403-111	131-8403-116
RG-179 DS, RG-187DS	131-8404-111	131-8404-116

Assembly instructions page 238.

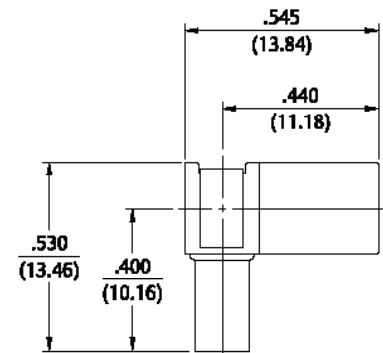

Straight Jack Receptacle



Gold Plated	Nickel Plated
131-8701-201	131-8701-206

Mounting hole layout figure 6 page 194.

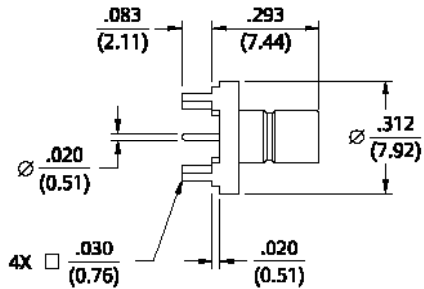

Straight Jack Receptacle



Cable Type	Gold Plated	"A"
131-8701-251	131-8701-256	.155 (3.94)
131-8701-261	131-8701-266	.095 (2.41)

Mounting hole layout figure 6 page 194.

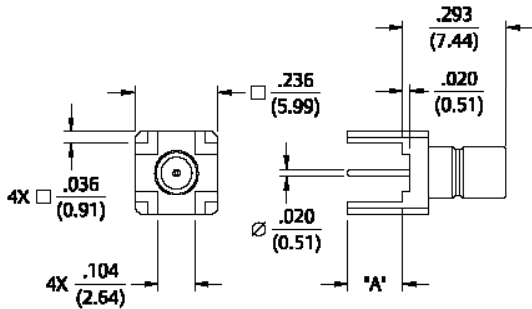

Straight Bulkhead Jack Receptacle



Gold Plated	Nickel Plated
131-8701-211	131-8701-216

Mounting hole layout figures 5 and 6 page 195.

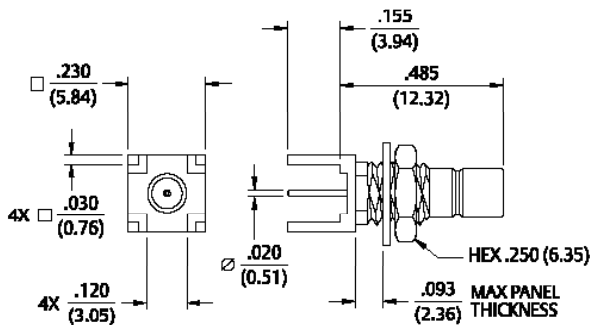

For more information, please contact customer service at (507) 833-8822 or (800) 247-8256 • cinch.com
Illustrations are shown in inches (millimeters).

PC Mount

Straight Jack Receptacle – Surface Mount



Gold Plated	Packaging
131-8711-201	Stock
131-8711-202	Tape and Reel 750 pcs/reel

Mounting hole layout figure 11 page 194.

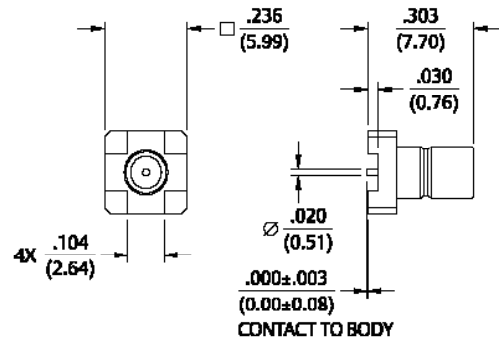

Right Angle Jack Receptacle



Gold Plated	Nickel Plated	"A"
131-8701-301	131-8701-306	.083
131-8701-311	131-8701-316	.125

Mounting hole layout figure 7 page 194.

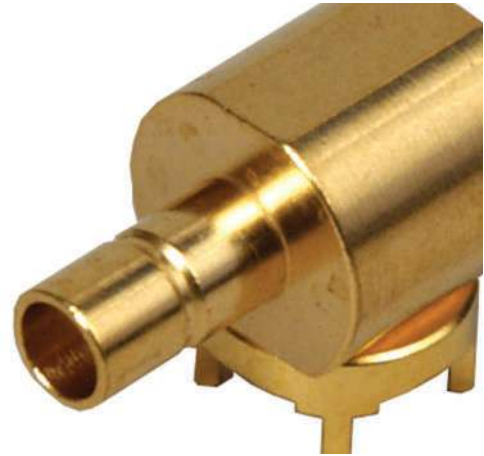

Right Angle Bulkhead Jack Receptacle



Gold Plated	Nickel Plated
131-8701-501	131-8701-506

Mounting hole layout figures 5 and 7 page 194.

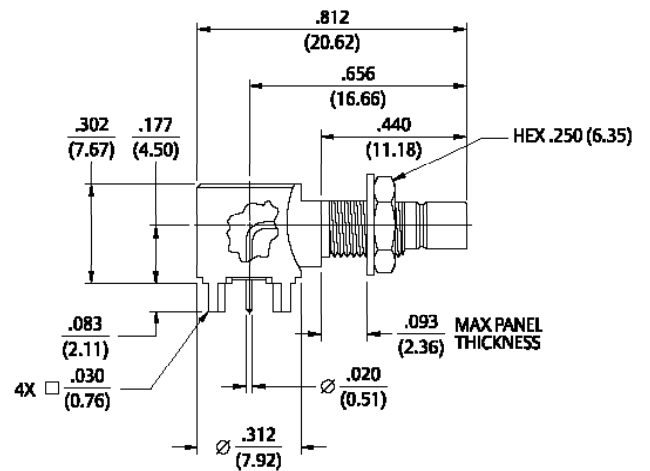

End Launch Jack Receptacle

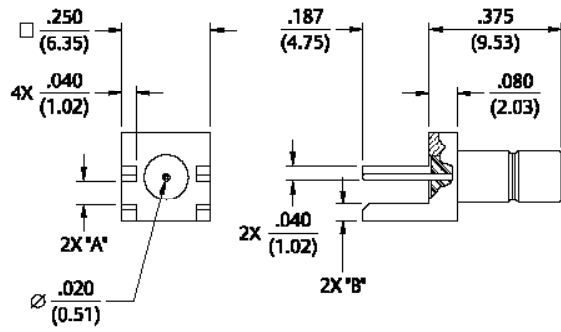

Gold Plated	Nickel Plated	Board Thickness	"A"	"B"
131-8701-841	131-8701-846	.062 (1.57)	.068 (1.73)	.047 (1.19)

2-Hole Flange Mount Jack Receptacle

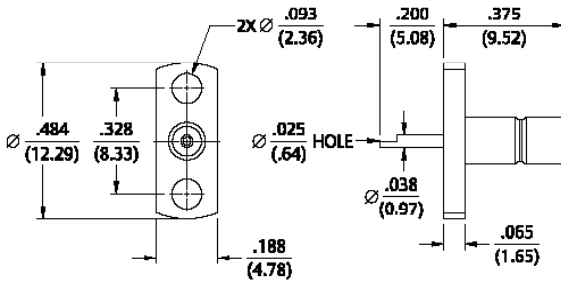

Gold Plated	Nickel Plated
131-8701-601	131-8701-606

For more information, please contact customer service at (507) 833-8822 or (800) 247-8256 • cinch.com

Illustrations are shown in inches (millimeters).

Terminations

Plug Precision Load



Gold Plated

131-8801-801

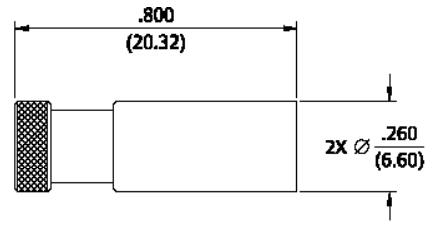

Matched Plug Open and Short



Type	Gold Plated
OPEN	131-8801-821
SHORT	131-8801-811

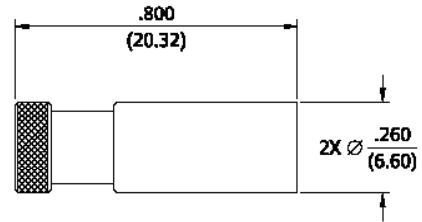

Matched Jack Open and Short



Type	Gold Plated
OPEN	131-8701-821
SHORT	131-8701-811

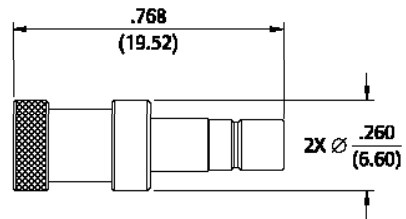

Jack to Jack Adapter

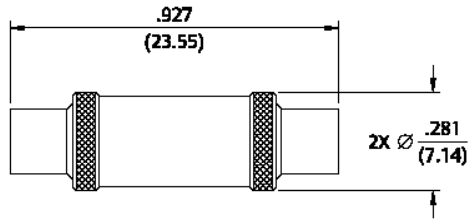

Gold Plated
131-8901-801

Plug to Plug Adapter

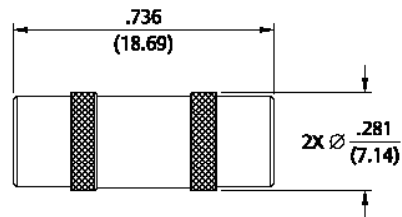

Gold Plated
131-8901-811

Jack to Plug Adapter

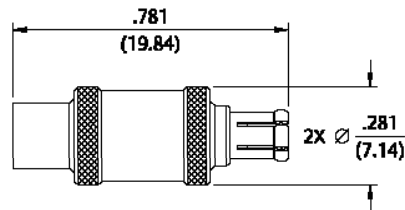

Gold Plated
131-8901-821

Jack to Bulkhead Jack* Adapter

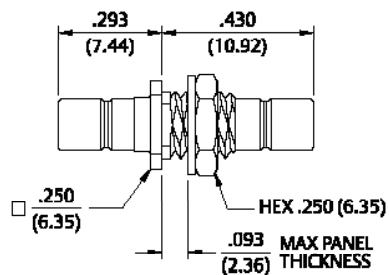

Gold Plated	Nickel Plated
131-8901-401	131-8901-406

Mounting hole layout figure 5 page 194. * Electrical length not matched to other adapters shown.

Between-Series Adapter

75 Ohm Type N Plug to Mini-75 Ohm SMB Plug Adapter



Stainless Steel Passivated

134-1069-001

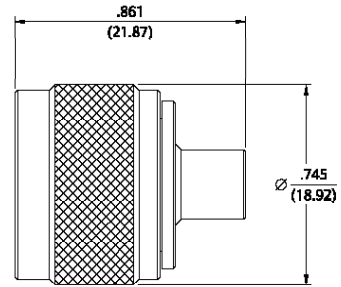

75 Ohm Type N Plug to Mini-75 Ohm SMB Jack Adapter



Stainless Steel Passivated

134-1069-011

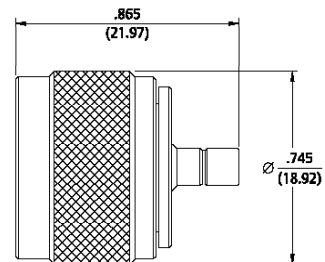

75 Ohm Type N Jack to Mini-75 SMB Plug Adapter



Stainless Steel Passivated

134-1069-021

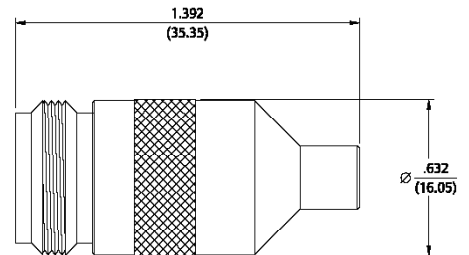

75 Ohm Type N Plug to Mini-75 Ohm SMB Jack Adapter



Stainless Steel Passivated

134-1069-031

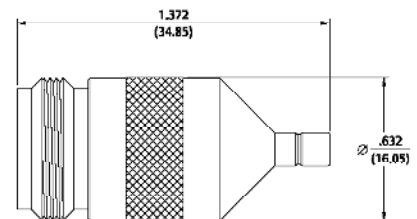

SMC Connectors

50 Ohm Connectors	
Specifications.....	132
Semi-Rigid & Flexible Cable	134
PC Mount.....	135
Bulkhead & Panel Mount.....	136
Other Information	
Assembly Tools	185
Capabilities	190
Cable Information	192
Assembly Instruction	193
Mounting Hole Layouts	194
Numerical Index	274
Competitor Cross Reference	280

3	MMCX Connectors
13	MCX Connectors
39	SMK Connectors
45	SMA Connectors
103	SMB Connectors
131	SMC Connectors
137	SMP Connectors
145	Type N Connectors
153	Shielded Cable Terminations
157	Between-Series Adapters
161	Fixed Length Cable Assemblies
173	Ultra Miniature Connectors (UMC)
181	kwiQMAt[™] Connectors
185	Tools
193	Assembly Instructions
257	Electronic Hardware
274	Index

While every precaution has been taken to ensure accuracy and completeness herein, Cinch Connectivity Solutions assumes no responsibility, and disclaims all liability for damages resulting from use of this information or for any errors or omissions. Specifications subject to change without notice.

Specifications

Electrical Specifications

Impedance: 50 Ohms

Frequency Range: 0-10 GHz

VSWR: (max) (f = GHz)

	<u>Straight Cabled Connectors</u>	<u>Right Angle Cabled Connectors</u>
RG-178	1.25 + .04f	1.40 + .06f
RG-316 and RG-405	1.20 + .04f	1.30 + .04f
Uncabled receptacles	N/A	

Working Voltage: (VRMS max)†

	<u>Sea Level</u>	<u>70K Feet</u>
RG-178	250	60
RG-316, RG-405 uncabled receptacles	335	85

Dielectric Withstanding Voltage: (VRMS min at sea level)†

RG-178	750
RG-316, RG-405 uncabled receptacles	1000

Corona Level: (Volts min at 70,000 feet)†

RG-178	185
RG-316, RG-405	250
Uncabled receptacles	N/A

Insertion Loss: (dB max, tested at 4 GHz)

Straight cabled connectors	0.25 dB
Right angle cabled connectors	0.50 dB
Uncabled receptacles	N/A

Insulation Resistance: 1000 megohms min

Contact Resistance: (milliohms max)

	<u>Initial</u>	<u>After Environmental</u>
Center contact (straight cabled connectors and uncabled receptacles)	6.0	8.0
Center contact (right angle cabled connectors)	12.0	16.0
Outer contact (gold plated connectors)	1.0	N/A
Outer contact (nickel plated connectors)	2.5	N/A
Braid to body (gold plated connectors)	1.0	N/A
Braid to body (nickel plated connectors)	2.5	N/A

RF Leakage: (dB min tested at 2.5 GHz)

Cabled connectors	-55 dB
Uncabled receptacles	N/A

RF High Potential Withstanding Voltage: (VRMS min, tested at 4 and 7 MHz)†

RG-178	500
RG-316	700
Uncabled receptacles	600

Mechanical Specifications

Engagement Design: MIL-STD-348, Series SMC

Engagement/Disengagement Force: 16 oz-in max torque

Mating Torque: 35 to 50 oz-in

Coupling Proof Torque: 100 oz-in min

Coupling Nut Retention: 35 lbs min

Contact Retention: 4 lbs min axial force (captivated contacts)

1 oz-in min torque (uncabled receptacles)

Cable Retention:

	<u>Axial Force* (lbs)</u>	<u>Torque (oz-in)</u>
RG-178	10	N/A
RG-316	20	N/A
RG-405	30	16

* or cable breaking strength whichever is less

Durability: 500 cycles min

Environmental Ratings

Meets or exceeds the applicable paragraph of MIL-PRF-39012

Temperature Range:	- 65°C to + 165°C
Thermal Shock:	MIL-STD-202, Method 107, Condition B
Corrosion:	MIL-STD-202, Method 101, Condition B
Shock:	MIL-STD-202, Method 213, Condition C
Vibration:	MIL-STD-202, Method 204, Condition D

Material Specifications

Bodies:	Brass per ASTM B16, gold plated per MIL-DTL-45204 .00001" min or nickel plated per SAE-AMS2432
Contacts:	Male – Brass per ASTM B16, gold plated per MIL-DTL-45204 .00003" min. Female – Beryllium copper per ASTM B196, gold plated per MIL-DTL-45204 .00003" min.
Nut Retention Spring:	Beryllium copper per ASTM B196, unplated
Insulators:	PTFE fluorocarbon per ASTM D 1710 and ASTM D 1457
Expansion Caps:	Brass per ASTM B36, gold plated per MIL-DTL-45204 .00001" min. or nickel plated per SAE-AMS2423
Crimp Sleeves:	Copper per ASTM B301, gold plated per MIL-DTL-45204 .00001" min. or nickel plated per SAE-AMS2423
Mounting Hardware:	Brass (nuts) per ASTM B16 or phosphor bronze (lockwashers) per ASTM B139, gold plated per MIL-DTL-45204 .00001" min. or nickel plated per SAE-AMS2423

** All Gold plated parts include a .00005" minimum Nickel under plated barrier layer

Mating Engagement for SMC Series

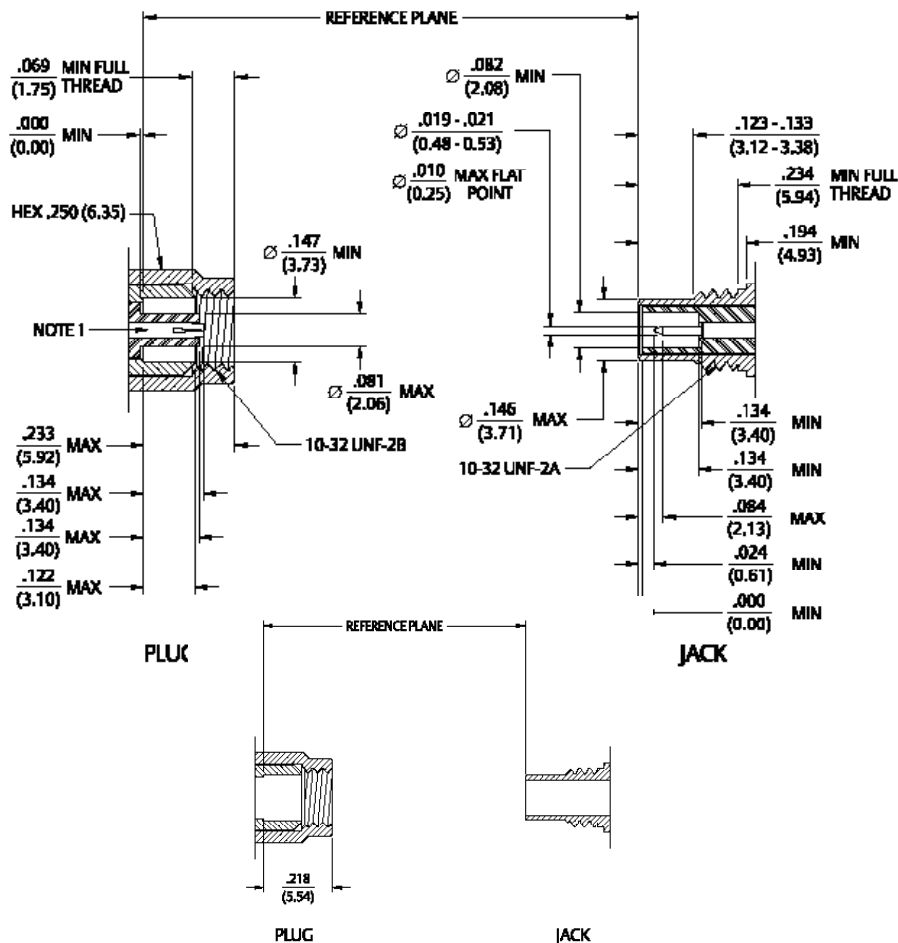

Notes:
1. Inside of contact to meet VSWR mating characteristics and connector durability when mated with a dia. .019/.021 (.48/.53) male contact.

For more information, please contact customer service at (507) 833-8822 or (800) 247-8256 • cinch.com
Illustrations are shown in inches (millimeters).

Semi-Rigid and Flexible Cable

Straight Solder Type Bulkhead Jack – Captivated Contact



Cable Type	Gold Plated	Nickel Plated
RG-405	131-6593-401	131-6593-406

Assembly instructions page 233.
Mounting hole layout figure 5 page 194.

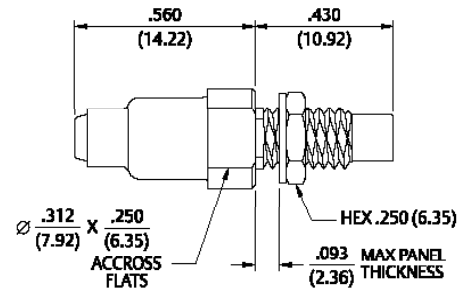

Straight Crimp Type Plug – Captivated Contact



Cable Type	Gold Plated	Nickel Plated
RG-161, 174, 188, 316	131-6403-001	131-6403-006
RG-316 DS, 188 DS	131-6404-001	131-6404-006
RG-179, 187	131-6433-001	131-6433-006

Assembly instructions page 237.

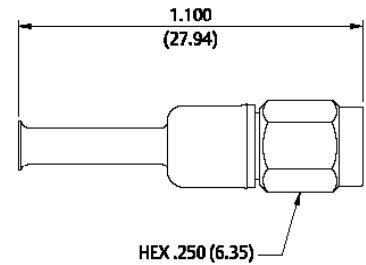

Right Angle Crimp Type Plug – Captivated Contact



Cable Type	Gold Plated	Nickel Plated
RG-161, 174, 188, 316	131-6403-101	131-6403-106
RG-316 DS, 188 DS	131-6404-101	131-6404-106
RG-179, 187	131-6433-101	131-6433-106

Assembly instructions page 238.

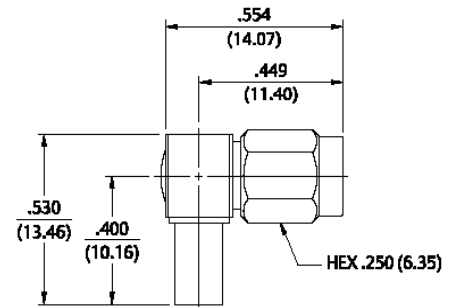

Straight Crimp Type Bulkhead Jack – Captivated Contact



Cable Type	Gold Plated	Nickel Plated
RG-161, 174, 188, 316	131-6303-401	131-6303-406
RG-316 DS, 188 DS	131-6304-401	131-6304-406
RG-179, 187	131-6333-401	131-6333-406

Assembly instructions page 237.
Mounting hole layout figure 5 page 194.

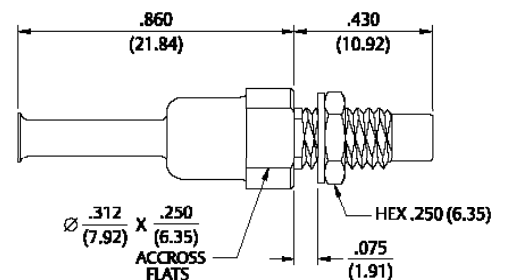

Straight Jack Receptacle



Gold Plated	Nickel Plated	"A"
131-6701-201	131-6701-206	.155 (3.94)
131-6701-211	131-6701-216	.110 (2.79)

Mounting hole layout figure 4 page 194.

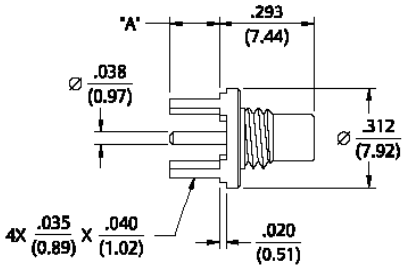

Straight Jack Receptacle – Surface Mount



Gold Plated
131-6711-201

Mounting hole layout figure 7 page 194.

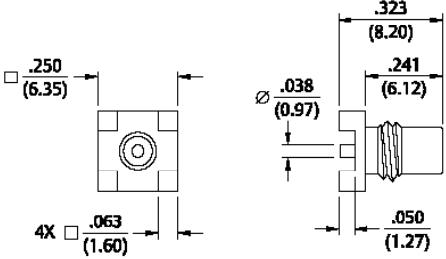

Right Angle Jack Receptacle



Gold Plated
131-6701-301

Mounting hole layout figure 4 page 194.

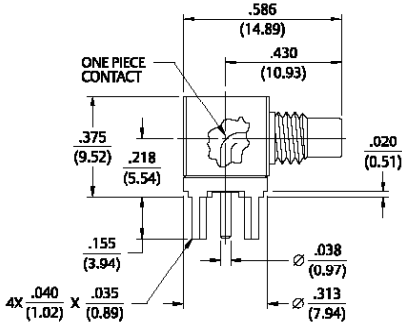

PC Mount and Bulkhead Mount

End Launch Jack Receptacle – Tab Contact

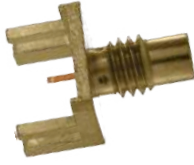

Gold Plated	Nickel Plated	Board Thickness
131-6701-831	131-6701-836	.062 (1.57)

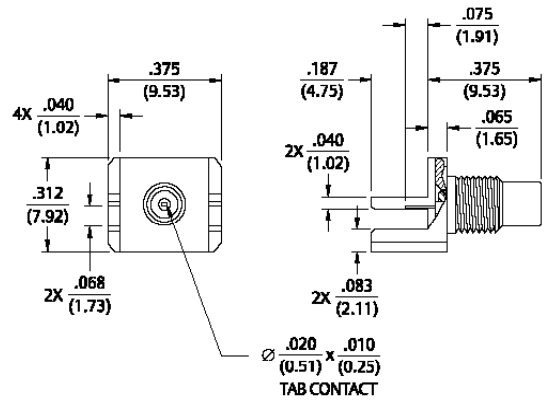

Front Mount Bulkhead Jack Receptacle



Gold Plated	Nickel Plated
131-6701-411	131-6701-416

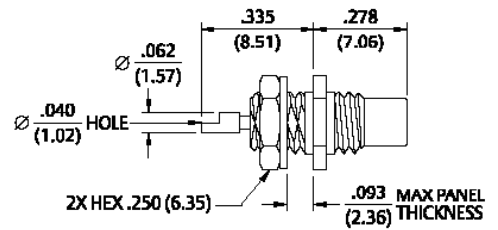

Rear Mount Bulkhead Jack Receptacle



Gold Plated	Nickel Plated
131-6701-401	131-6701-406

Mounting hole layout figure 5 page 194.

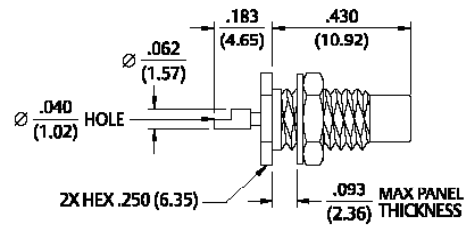

SMP Connectors

50 Ohm Connectors	
Specifications.....	139
Semi-Rigid & Flexible Cable	142
PC Mount.....	142
Bulkhead & Panel Mount.....	143
Other Information	
Assembly Tools	185
Capabilities	190
Cable Information	192
Assembly Instruction	193
Mounting Hole Layouts	194
Numerical Index	274
Competitor Cross Reference	280

3	MMCX Connectors
13	MCX Connectors
39	SMK Connectors
45	SMA Connectors
103	SMB Connectors
131	SMC Connectors
137	SMP Connectors
145	Type N Connectors
153	Shielded Cable Terminations
157	Between-Series Adapters
161	Fixed Length Cable Assemblies
173	Ultra Miniature Connectors (UMC)
181	kwiQMate™ Connectors
185	Tools
193	Assembly Instructions
257	Electronic Hardware
274	Index

While every precaution has been taken to ensure accuracy and completeness herein, Cinch Connectivity Solutions assumes no responsibility, and disclaims all liability for damages resulting from use of this information or for any errors or omissions. Specifications subject to change without notice.

Introduction

Description

One of the key benefits of the SMP connector interface is its use in high frequency blind-mate applications. The design of the SMP bullet and shroud system allows for both axial and radial misalignment. The basic system is comprised of an inner “bullet” adapter, and two outer receptacles called “shrouds”. The bullet provides a flexible link between the shroud connections.

In blind-mate applications, one shroud connector will be typically specified as a snap-on interface and the other as a slide-on. This ensures that the bullet adapter remains fixed in the same shroud connector when the connection is disengaged.

The two snap-on interfaces Full Detent (FD) and Limited Detent (LD) each have different engage and disengage coupling forces. The LD is typically selected as the snap-on interface in PCB mount or blind-mate applications, while the FD is mainly used for cabled connections where higher retention forces are required.

The two slide-on interfaces Smooth Bore (SB) and Catcher’s Mitt (CM) allow for reduced connection forces as compared to the snap-on versions. The push-on interface creates a sliding connection that does not physically locate the mating reference planes, allowing for axial and radial misalignment. Both the SB and CM have the same engage/disengage forces; however the CM is typically specified as the shroud configuration in blind-mate applications as its generous lead-in chamfer helps capture and guide the bullet into place.

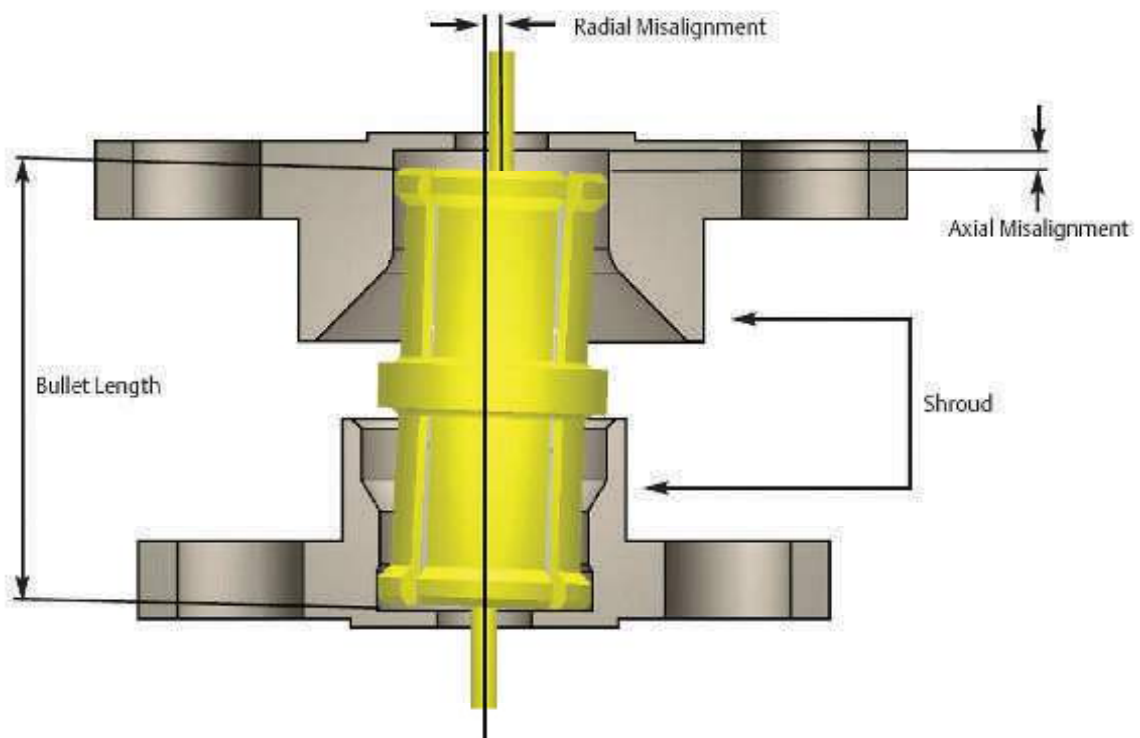

Electrical Specifications

Impedance: 50 Ohms

Frequency Range:

Bullet Adapter (.254 length), Semi-Rigid Straight Cabled Connectors	0-40 GHz			
All other In-Series Adapters, Semi-Rigid Right Angle Cabled Connectors, Field Replaceable Connectors, End Launch Connectors, Hermetic Feedthroughs.....	0-18 GHz			
PC Mount Connectors	0-12 GHz			
VSWR: (max) (f = GHz)	<u>0-18 GHz</u>	<u>18-23 GHz</u>	<u>23-26.5 GHz</u>	<u>26.5-40 GHz</u>
Bullet Adapter (.254 length)	1.10	1.15	1.30	1.70
Semi-Rigid Straight Cabled Connectors		<u>0-18 GHz</u>	<u>18-26.5 GHz</u>	<u>26.5-40 GHz</u>
		1.20	1.35	1.70
All other In-Series Adapters		<u>0-4 GHz</u>	<u>4-12 GHz</u>	<u>12-18 GHz</u>
		1.10	1.15	1.20
Semi-Rigid Right Angle Cabled Connectors				<u>0-18 GHz</u>
				1.20
Field Replaceable Connectors (typical, measured back to back with seal pin).....				<u>0-18 GHz</u>
Un-cabled Connectors (dependant on application).....				1.15
				N/A

Working Voltage: 335 VRMS max at sea level, 65 VRMS max at 70,000 feet

Dielectric Withstanding Voltage: 500 Vrms min at sea level

Insulation Resistance: 5000 megohms min

Contact Resistance: (milliohms max initial, not applicable after environmental testing)

Center Contact (Connectors and Adapters)	6.0
Outer Contact (Connectors and Adapters)	2.0
Cable Shield to Body (Semi-Rigid Cabled Connectors Only)	0.5

Corona Level: 190 VRMS min at 70,000 feet

Insertion Loss: (dB max)

Insertion Loss: (dB max, tested at 10 GHz)

In-Series Adapters, Field Replaceable Connectors	$0.10\sqrt{f} \text{ (GHz)}$
Semi-Rigid Cabled Connectors	$0.12\sqrt{f} \text{ (GHz)}$
All other Un-cabled Connectors	N/A

Insertion Loss: (dB max)

RF Leakage: (dB typical, tested at 2.5 GHz)

Cabled and Field Replaceable Connectors	-80
In-Series Adapters	-65
All other Un-cabled Connectors	N/A

RF High Potential Withstanding Voltage: 325 VRMS min at sea level, tested at 4 and 7 MHz

Mechanical Specifications

Interface Design: MIL-STD-348A, Series SMP

Engagement Force: (lbs max, mated pair)

Full Detent (FD)	15.0
Limited Detent (LD)	10.0
Smooth Bore and Catcher's Mitt (SB and CM)	2.0

Disengagement Force: (lbs min, mated pair)

Full Detent (FD)	5.0
Limited Detent (LD)	2.0
Smooth Bore and Catcher's Mitt (SB and CM)	0.5

Mated Radial Misalignment: (in max allowed, female adapters only)

Between Centerlines of Mating Planes (FD, LD, SB)010
Between Centerlines of Mating Planes (CM only).....	.020

Mated Axial Misalignment: .010 in max allowed between mating planes (female adapters only)

Durability: (mating cycles min)

Full Detent (all female connectors and adapters).....	100
Limited Detent (female adapters only)	500
Smooth Bore and Catcher's Mitt (female adapters only)	1000

Contact Retention: 1.5 lbs min axial force (captivated contacts only)

Cable Retention: (min)	<u>Axial Force* (lbs)</u>	<u>Torque (oz-in)</u>
Cabled Connectors for RG-405.....	30	16.0
Cabled Connectors for M17/151	20	N/A

* Or cable breaking strength, whichever is less

For more information, please contact customer service at (507) 833-8822 or (800) 247-8256 • cinch.com

Illustrations are shown in inches (millimeters).

Specifications

Environmental Ratings

(Meets or exceeds the applicable paragraph of MIL-PRF-39012)

Operating Temperature:	-65°C to +165°C
Thermal Shock:	MIL-STD-202, Method 107, Condition B (except high temp +165°C or max high temp of cable)
Corrosion:	MIL-STD-202, Method 101, Condition B
Shock (specified pulse):	MIL-STD-202, Method 213, Condition I
Vibration:	MIL-STD-202, Method 204, Condition D
Moisture Resistance:	MIL-STD-202, Method 106 (except step 7b omitted)

Material Specifications

Spring Finger (female) and End Launch (male) Bodies:	Beryllium Copper per ASTM B196, Gold plated* per MIL-DTL-45204 (.00005" min)
Hermetic Seal Bodies (male):	Kovar Alloy per ASTM F15, Gold plated* per MIL-DTL-45204 (.00005" min)
All other Shroud Bodies (male):	Stainless Steel, Type 303, per ASTM A582, Passivated per MIL-DTL-14072 (EL 300)
Connector and Adapter Contacts (male and female):	Beryllium Copper per ASTM B196, Gold plated* per MIL-DTL-45204 (.00005" min)
Hermetic Seal Center Pins:	Kovar Alloy per ASTM F15, Gold plated* per MIL-DTL-45204 (.00005" min)
EMI/Anti-Rock Rings:	Beryllium Copper per ASTM B196, Gold plated* per MIL-DTL-45204 (.00003" min)
PC Mount Legs:	Brass per ASTM B16, Gold plated* per MIL-DTL-45204 (.00003" min)
Connector and Adapter Insulators:	PTFE per ASTM D1710
Hermetic Seal Glass:	Corning 7070

* All Gold plated parts include a .00005" minimum Nickel barrier layer

Typical Measured Return Loss Bullet Adapter 127-0901-801

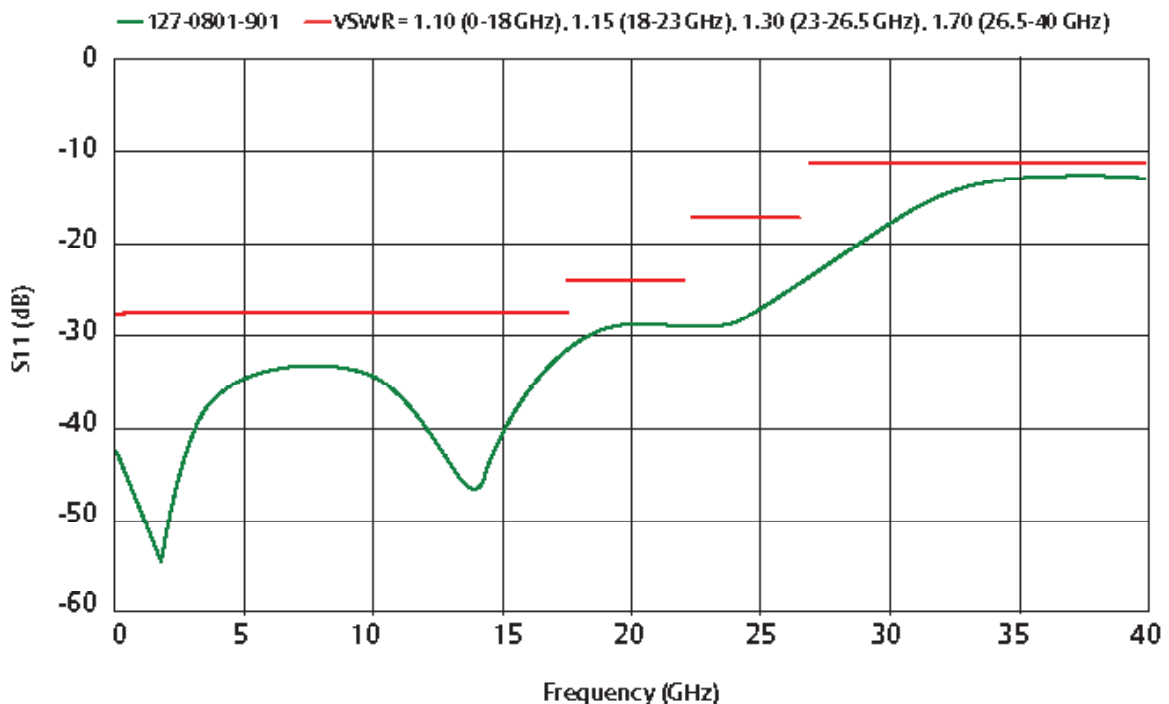

Mating Engagement for SMP Series per MIL-STD-348A

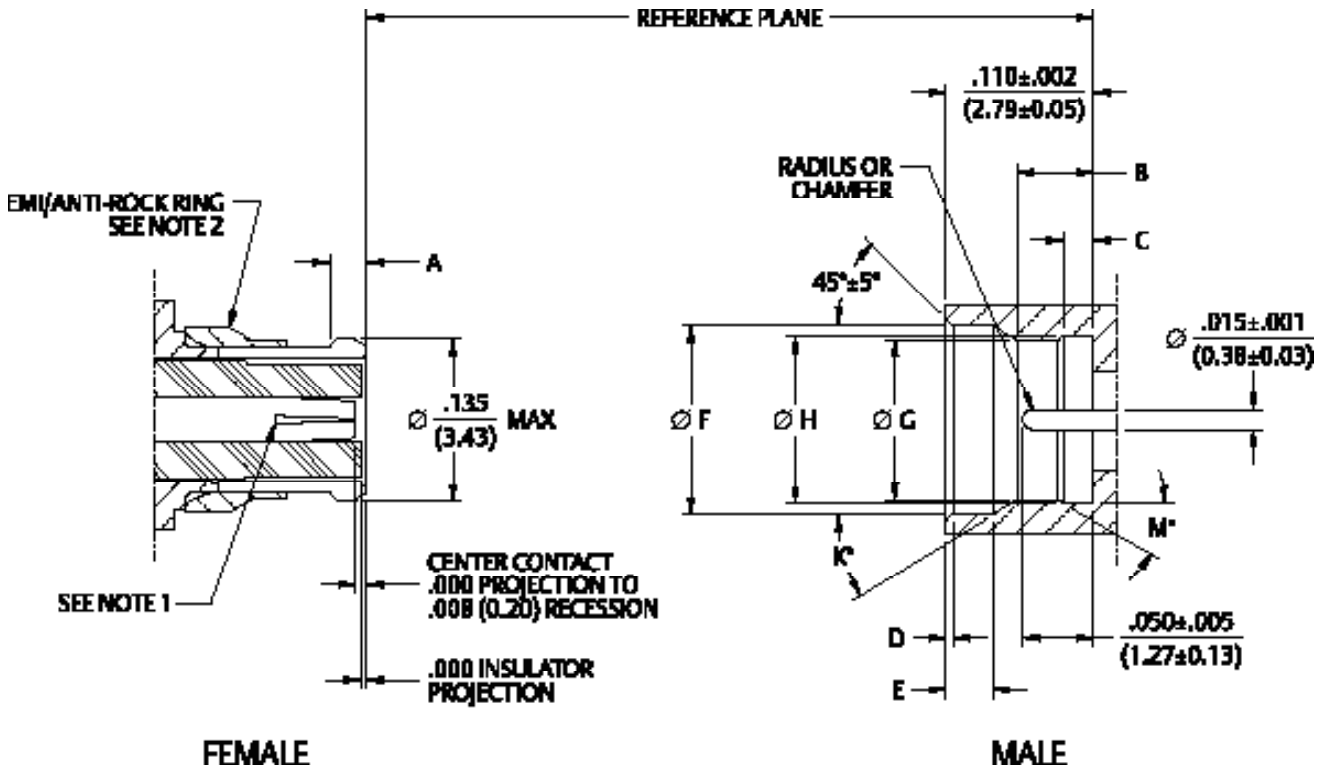

Notes:

1. Socket to accept mating pin $\varnothing.015\pm.001$ (0.38±0.03).
2. EMI/Anti-Rock Ring configuration optional, used on cabled connectors only. Shall not prevent proper mating engagement.
3. All dimensions shown in inches. Metric equivalents (rounded to nearest 0.01mm) are given for general information only.

SMP Female Connector Interface

Dimension	Cabled		Uncabled	
	Min	Max	Min	Max
A	.025 (0.64)	.035 (0.89)	.018 (0.46)	.025 (0.64)

SMP Male Connector Interface

Dimension	Full Detent		Limited Detent		Smooth Bore		Catcher's Mitt	
	Min	Max	Min	Max	Min	Max	Min	Max
B	.051 (1.30)	.057 (1.45)	.054 (1.37)	.060 (1.52)	.059 (1.50)	.065 (1.65)	N/A	N/A
C	.0205 (0.52)	.0235 (0.60)	.0205 (0.52)	.0235 (0.60)	N/A	N/A	N/A	N/A
D	.003 (0.08)	.008 (0.20)	.003 (0.08)	.008 (0.20)	.003 (0.08)	.008 (0.20)	.043 (1.09)	.047 (1.19)
E	.033 (0.84)	.037 (0.94)	.033 (0.84)	.037 (0.94)	.033 (0.84)	.037 (0.94)	N/A	N/A
F	.139 (3.53)	.145 (3.68)	.139 (3.53)	.145 (3.68)	.139 (3.53)	.145 (3.68)	.123 (3.12)	.127 (3.23)
G	.114 (2.90)	.118 (3.00)	.118 (3.00)	.122 (3.10)	.123 (3.12)	.127 (3.23)	N/A	N/A
H	.124 (3.15)	.126 (3.20)	.124 (3.15)	.126 (3.20)	N/A	N/A	N/A	N/A
K	35° REF	35° REF	35° REF	35° REF	35° REF	35° REF	N/A	N/A
M	30° REF	30° REF	30° REF	30° REF	N/A	N/A	N/A	N/A

For more information, please contact customer service at (507) 833-8822 or (800) 247-8256 • cinch.com

Illustrations are shown in inches (millimeters).

Semi-Rigid Cable and PC Mount

Female Straight Cabled, Semi-Rigid

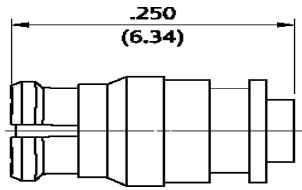

Fig 1

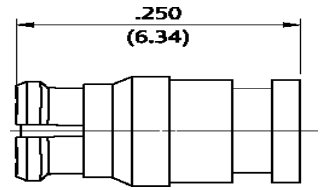
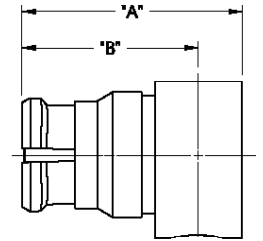
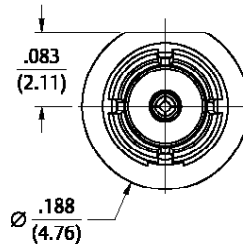

Fig 2

Cable Type	Gold Plated	Figure
M17/151	127-0692-001	1
RG-405	127-0693-001	2

* Specifications dependant on cable ratings.

Right Angle Cabled Female



Cable Type	Gold Plated	"A"	"B"
M17/151	127-0692-101	.248 (6.30)	.197 (5.00)
RG-405	127-0693-101	.271 (6.88)	.209 (5.31)

* Specifications dependant on cable ratings.

Straight PC Mount Male Receptacle

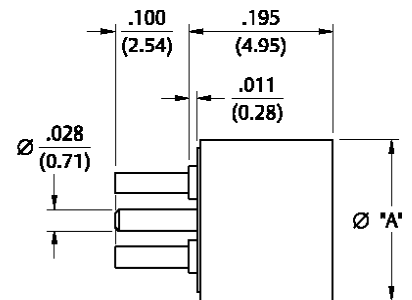
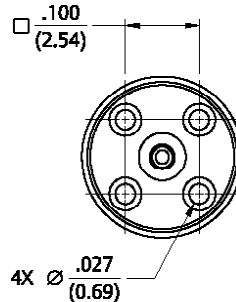

Interface	Passivated	"A"
Full Detent	127-0701-201	.218 (5.54)
Limited Detent	127-1701-201	.218 (5.54)
Smooth Bore	127-2701-201	.218 (5.54)
Catcher's Mitt	127-3701-201	.234 (5.94)

Base and legs gold plated brass.

End Launch Male Receptacle – Surface Mount



Interface	Gold Plated	Packaging
Full Detent	127-0701-801	Stock
Full Detent	127-0701-802	Tape and Reel 1000 pcs/reel
Limited Detent	127-1701-801	Stock
Limited Detent	127-1701-802	Tape and Reel 1000 pcs/reel
Smooth Bore	127-2701-801	Stock
Smooth Bore	127-2701-802	Tape and Reel 1000 pcs/reel

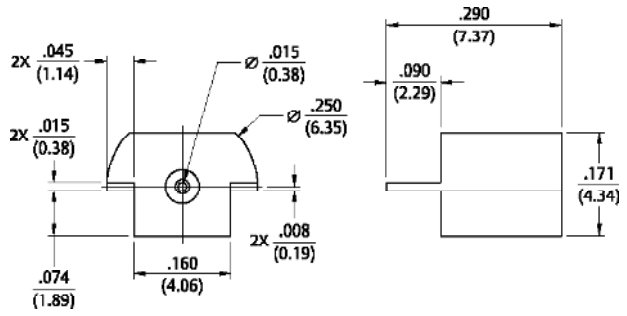

Mounting hole layout figure 1 page 194.

2-Hole Flange Mount Male Shroud – Without Contact



Interface	Passivated
Full Detent	127-0701-602
Limited Detent	127-1701-602
Smooth Bore	127-2701-602

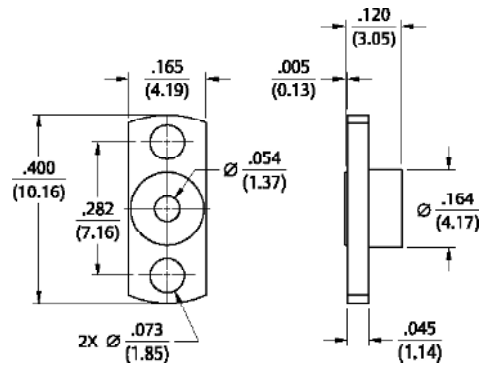

2-Hole Flange Mount Male Catcher's Mitt Shroud – Without Contact



Interface	Passivated
Catcher's Mitt	127-3701-602

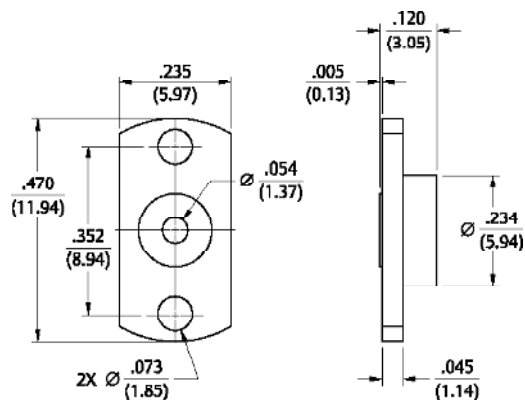

For more information, please contact customer service at (507) 833-8822 or (800) 247-8256 • cinch.com
 Illustrations are shown in inches (millimeters).

Panel Mount and Adapters

2-Hole Flange Mount Male Field Replaceable



Interface	Passivated	Pin Size
Full Detent	127-0701-612	.012 (.030)
Limited Detent	127-1701-612	.012 (.030)
Smooth Bore	127-2701-612	.012 (.030)

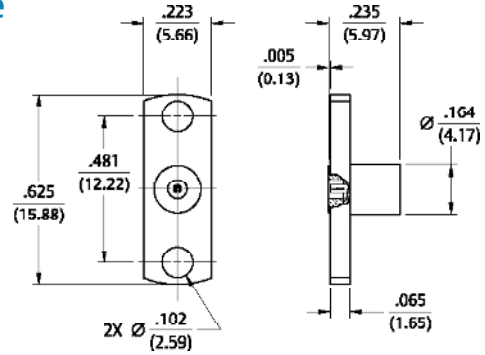

Hermetic Seal Male



Interface	Gold Plated
Full Detent	127-0711-601
Limited Detent	127-1711-601
Smooth Bore	127-2711-601

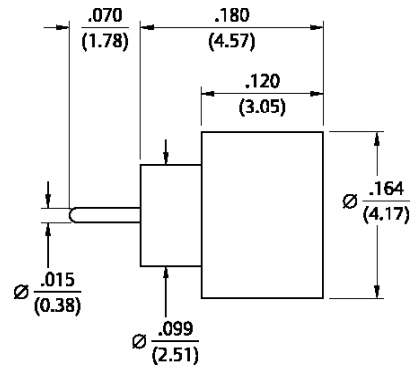

Female to Female Bullet Adapter



Gold Plated
127-0901-801



Female to Female Adapter



Gold Plated
127-0901-811



Male to Male Catcher's Mitt Adapter



Interface	Passivated
Full Detent	127-0901-821
Limited Detent	127-1901-822
Smooth Bore	127-2901-821

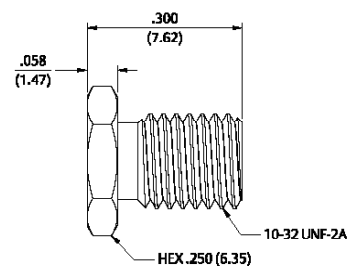

Type N Connectors

50 Ohm Connectors	
Specifications.....	146
Semi-Rigid & Flexible Cable	149
Bulkhead & Panel Mount Mount	151
Adapters	151
Other Information	
Assembly Tools	185
Capabilities	190
Cable Information	192
Assembly Instruction	193
Mounting Hole Layouts	194
Numerical Index	274
Competitor Cross Reference	280

3	MMCX Connectors
13	MCX Connectors
39	SMK Connectors
45	SMA Connectors
103	SMB Connectors
131	SMC Connectors
137	SMP Connectors
145	Type N Connectors
153	Shielded Cable Terminations
157	Between-Series Adapters
161	Fixed Length Cable Assemblies
173	Ultra Miniature Connectors (UMC)
181	kwiQMate™ Connectors
185	Tools
193	Assembly Instructions
257	Electronic Hardware
274	Index

While every precaution has been taken to ensure accuracy and completeness herein, Cinch Connectivity Solutions assumes no responsibility, and disclaims all liability for damages resulting from use of this information or for any errors or omissions. Specifications subject to change without notice.

Specifications

Electrical Specifications

Impedance: 50 Ohms

Frequency Range:

Flexible Cabled Connectors and Receptacles.....0-11 GHz

Semi-rigid Cabled Connectors and Receptacles0-18 GHz

VSWR: max (f-GHz).....0-11 GHz

Straight Flexible Cabled Connectors.....1.30 max

	<u>0-9 GHz</u>	<u>9-11 GHz</u>
Right Angle Flexible Cabled	1.35 max	1.50 max

	<u>0-11 GHz</u>	<u>11-18 GHz</u>
RG-405 Semi-Rigid Plugs.....	1.07+.01f	<1.25 Typical

RG-402 Semi-Rigid Plugs.....	1.05+.01f	<1.25 Typical
------------------------------	-----------	---------------

RG-401 Semi-Rigid Plugs.....	1.06+.01f	<1.25 Typical
------------------------------	-----------	---------------

RG-405 Semi-Rigid Jacks.....	1.15+.02f	<1.50 Typical
------------------------------	-----------	---------------

RG-402 Semi-Rigid Jacks.....	1.10+.02f	<1.50 Typical
------------------------------	-----------	---------------

RG-401 Semi-Rigid Jacks.....	1.10+.02f	<1.50 Typical
------------------------------	-----------	---------------

	0-18 GHz	
Adapters.....	1.05+.01f	

Uncabled Receptacles.....	N/A	
---------------------------	-----	--

Working Voltage: (VRMS max)†

	<u>Sea Level</u>	<u>70K Feet</u>
RG-316, 316 DS.....	250	65

RG-58, 142, 405.....	335	85
----------------------	-----	----

RG-402.....	500	125
-------------	-----	-----

RG-213, 214, 401, LMR-400.....	1000	250
--------------------------------	------	-----

Uncabled Receptacles and Adapters.....	1000	250
--	------	-----

Dielectric Withstanding Voltage: (VRMS min at sea level)†

RG-316, 316 DS.....	750
---------------------	-----

RG-58, 142, 405.....	1000
----------------------	------

RG-402.....	1500
-------------	------

RG-213, 214, 401, LMR-400.....	2500
--------------------------------	------

Uncabled Receptacles and Adapters.....	2500
--	------

Insulation Resistance: 5000 Megohms min

Contact Resistance: (milliohms max)

	<u>Initial</u>	<u>After</u>
Center Contact		<u>Environmental</u>

Straight Cabled Connectors (non-captivated).....	1.0	1.5
--	-----	-----

Straight Cabled Connectors (captivated).....	2.5	3.0
--	-----	-----

Right Angle Cabled Connectors.....	2.5	3.0
------------------------------------	-----	-----

Uncabled Receptacles and Adapters.....	1.0	1.5
--	-----	-----

Outer Contact.....	0.2	N/A
--------------------	-----	-----

Braid to Body (Flexible Cabled Connectors Only).....	0.05	N/A
--	------	-----

	Initial	After
		Environmental

Center Contact		1.5
----------------	--	-----

Straight Cabled Connectors (non-captivated).....	1.0	1.5
--	-----	-----

Straight Cabled Connectors (captivated).....	2.5	3.0
--	-----	-----

Right Angle Cabled Connectors.....	2.5	3.0
------------------------------------	-----	-----

Uncabled Receptacles and Adapters.....	1.0	1.5
--	-----	-----

Outer Contact.....	0.2	N/A
--------------------	-----	-----

Braid to Body (Flexible Cabled Connectors Only).....	0.05	N/A
--	------	-----

	Initial	After
		Environmental

Center Contact		1.5
----------------	--	-----

Straight Cabled Connectors (non-captivated).....	1.0	1.5
--	-----	-----

Straight Cabled Connectors (captivated).....	2.5	3.0
--	-----	-----

Right Angle Cabled Connectors.....	2.5	3.0
------------------------------------	-----	-----

Uncabled Receptacles and Adapters.....	1.0	1.5
--	-----	-----

Outer Contact.....	0.2	N/A
--------------------	-----	-----

Braid to Body (Flexible Cabled Connectors Only).....	0.05	N/A
--	------	-----

	Initial	After
		Environmental

Center Contact		1.5
----------------	--	-----

Straight Cabled Connectors (non-captivated).....	1.0	1.5
--	-----	-----

Straight Cabled Connectors (captivated).....	2.5	3.0
--	-----	-----

Right Angle Cabled Connectors.....	2.5	3.0
------------------------------------	-----	-----

Uncabled Receptacles and Adapters.....	1.0	1.5
--	-----	-----

Outer Contact.....	0.2	N/A
--------------------	-----	-----

Braid to Body (Flexible Cabled Connectors Only).....	0.05	N/A
--	------	-----

	Initial	After
		Environmental

Center Contact		1.5
----------------	--	-----

Straight Cabled Connectors (non-captivated).....	1.0	1.5
--	-----	-----

Straight Cabled Connectors (captivated).....	2.5	3.0
--	-----	-----

Right Angle Cabled Connectors.....	2.5	3.0
------------------------------------	-----	-----

Uncabled Receptacles and Adapters.....	1.0	1.5
--	-----	-----

Outer Contact.....	0.2	N/A
--------------------	-----	-----

Braid to Body (Flexible Cabled Connectors Only).....	0.05	N/A
--	------	-----

	Initial	After
		Environmental

Center Contact		1.5
----------------	--	-----

Straight Cabled Connectors (non-captivated).....	1.0	1.5
--	-----	-----

Straight Cabled Connectors (captivated).....	2.5	3.0
--	-----	-----

Right Angle Cabled Connectors.....	2.5	3.0
------------------------------------	-----	-----

Uncabled Receptacles and Adapters.....	1.0	1.5
--	-----	-----

Outer Contact.....	0.2	N/A
--------------------	-----	-----

Braid to Body (Flexible Cabled Connectors Only).....	0.05	N/A
--	------	-----

	Initial	After
		Environmental

Center Contact		1.5
----------------	--	-----

Straight Cabled Connectors (non-captivated).....	1.0	1.5
--	-----	-----

Straight Cabled Connectors (captivated).....	2.5	3.0
--	-----	-----

Right Angle Cabled Connectors.....	2.5	3.0
------------------------------------	-----	-----

Uncabled Receptacles and Adapters.....	1.0	1.5
--	-----	-----

Outer Contact.....	0.2	N/A
--------------------	-----	-----

Braid to Body (Flexible Cabled Connectors Only).....	0.05	N/A
--	------	-----

	Initial	After
		Environmental

Center Contact		1.5
----------------	--	-----

Straight Cabled Connectors (non-captivated).....	1.0	1.5
--	-----	-----

Straight Cabled Connectors (captivated).....	2.5	3.0
--	-----	-----

Right Angle Cabled Connectors.....	2.5	3.0
------------------------------------	-----	-----

Uncabled Receptacles and Adapters.....	1.0	1.5
--	-----	-----

Outer Contact.....	0.2	N/A
--------------------	-----	-----

Braid to Body (Flexible Cabled Connectors Only).....	0.05	N/A
--	------	-----

	Initial	After
		Environmental

Center Contact		1.5
----------------	--	-----

Straight Cabled Connectors (non-captivated).....	1.0	1.5
--	-----	-----

Straight Cabled Connectors (captivated).....	2.5	3.0
--	-----	-----

Right Angle Cabled Connectors.....	2.5	3.0
------------------------------------	-----	-----

Uncabled Receptacles and Adapters.....	1.0	1.5
--	-----	-----

Outer Contact.....	0.2	N/A
--------------------	-----	-----

Braid to Body (Flexible Cabled Connectors Only).....	0.05	N/A
--	------	-----

	Initial	After
		Environmental

Center Contact		1.5
----------------	--	-----

Straight Cabled Connectors (non-captivated).....	1.0	1.5
--	-----	-----

Straight Cabled Connectors (captivated).....	2.5	3.0
--	-----	-----

Right Angle Cabled Connectors.....	2.5	3.0
------------------------------------	-----	-----

Uncabled Receptacles and Adapters.....	1.0	1.5
--	-----	-----

Outer Contact.....	0.2	N/A
--------------------	-----	-----

Braid to Body (Flexible Cabled Connectors Only).....	0.05	N/A
--	------	-----

	Initial	After
		Environmental

Center Contact		1.5
----------------	--	-----

Straight Cabled Connectors (non-captivated).....	1.0	1.5
--	-----	-----

Straight Cabled Connectors (captivated).....	2.5	3.0
--	-----	-----

Right Angle Cabled Connectors.....	2.5	3.0
------------------------------------	-----	-----

Uncabled Receptacles and Adapters.....	1.0	1.5
--	-----	-----

Outer Contact.....	0.2	N/A
--------------------	-----	-----

Braid to Body (Flexible Cabled Connectors Only).....	0.05	N/A
--	------	-----

	Initial	After
		Environmental

Center Contact		1.5
----------------	--	-----

Straight Cabled Connectors (non-captivated).....	1.0	1.5
--	-----	-----

Straight Cabled Connectors (captivated).....	2.5	3.0
--	-----	-----

Right Angle Cabled Connectors.....	2.5	3.0
------------------------------------	-----	-----

Uncabled Receptacles and Adapters.....	1.0	1.5
--	-----	-----

Outer Contact.....	0.2	N/A
--------------------	-----	-----

Braid to Body (Flexible Cabled Connectors Only).....	0.05	N/A
--	------	-----

	Initial	After
		Environmental

Center Contact		1.5
----------------	--	-----

Straight Cabled Connectors (non-captivated).....	1.0	1.5
--	-----	-----

Straight Cabled Connectors (captivated).....	2.5	3.0
--	-----	-----

Right Angle Cabled Connectors.....	2.5	3.0
------------------------------------	-----	-----

Uncabled Receptacles and Adapters.....	1.0	1.5
--	-----	-----

Outer Contact.....	0.2	N/A
--------------------	-----	-----

Braid to Body (Flexible Cabled Connectors Only).....	0.05	N/A
--	------	-----

	Initial	After
		Environmental

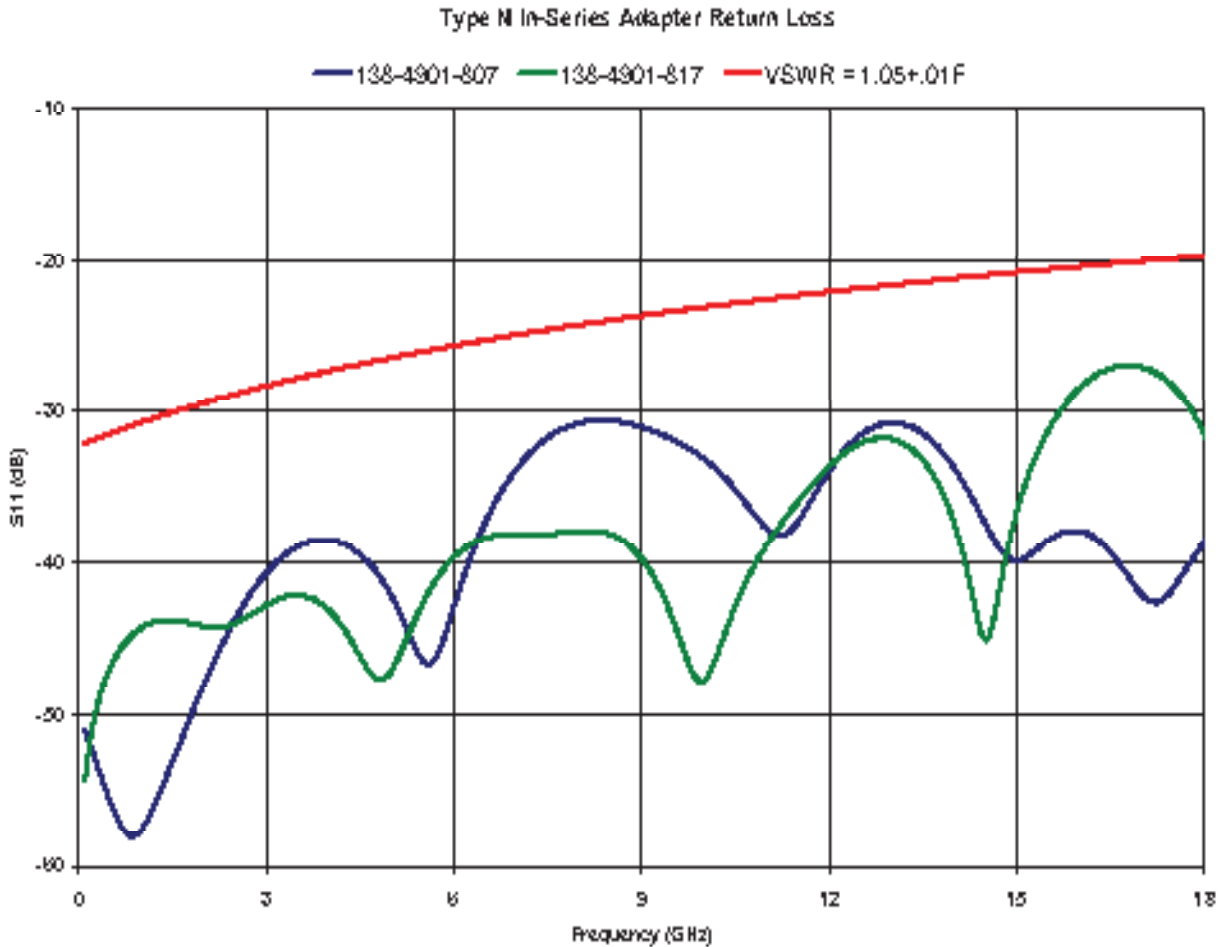

Mechanical Specifications

Engagement Design:	MIL-STD-348A, Series N
Durability:	500 Cycles min
Engagement/Disengagement Force:	6 lb-in max
Mating Torque:	7 to 10 lb-in
Bulkhead Mounting Nut Torque:	15 lb-in recommended
Coupling Proof Torque:	15 lb-in min
Coupling Nut Retention:	100 lbs min
Contact Retention:	(min - captivated contacts only)

	<u>Axial Force (lbs)</u>	<u>Torque (oz-in)</u>
Cabled Connectors and Adapters	6	N/A
Uncabled Receptacles	6	4

Cable Retention: (minimum*)

	<u>Axial Force (lbs)</u>	<u>Torque (oz-in)</u>
RG-316	20	N/A
RG-316DS	30	N/A
RG-58	40	N/A
RG-142	45	N/A
RG-213, 214 and LMR-400	90	N/A
RG-405	30	16
RG-402	60	55
RG-401	90	80

* or cable breaking strength, whichever is less.

For more information, please contact customer service at (507) 833-8822 or (800) 247-8256 • cinch.com

Illustrations are shown in inches (millimeters).

Specifications

Environmental Specifications

(Meets or Exceeds the Applicable Paragraph of MIL-PRF-39012)

Temperature Range:	-65°C to +165°C
Thermal Shock:	MIL-STD-202, Method 107, Condition B (except +85°C high temperature)
Corrosion:	MIL-STD-202, Method 101, Condition B
Shock:	MIL-STD-202, Method 213, Condition I
Vibration:	MIL-STD-202, Method 204, Condition B
Moisture Resistance:	MIL-STD-202, Method 106

Material Specifications

Bodies:	Crimp – Brass per ASTM B16, Tri-Alloy (Cu/Sn/Zn) plated (.0001" min)
	Solder – Brass per ASTM B16, Gold plated* per SAE-AMS2423 (.00001" min)
	Adapter – Brass per ASTM B16, Tri-Alloy (Cu/Sn/Zn) or Nickel per QQ-N-290 plated (.0001" min)
Contacts:	Male – Brass per ASTM B16, Gold plated* per MIL-G-45204 (.00005" min)
	Female – Beryllium Copper per ASTM B196, Gold plated* per MIL-DTL-45204 (.00005" min)
	Adapter – Beryllium Copper per ASTM B196, Gold plated* per MIL-DTL-45204 (.00005" min)
Insulators:	PTFE Fluorocarbon per ASTM D1710 and ASTM D1457
Gaskets:	Silicon Rubber per A-A-59588A
Crimp Sleeves:	Copper per ASTM B301, Tri-Alloy (Cu/Sn/Zn) plated (.0001" min)
End Caps:	Brass per ASTM B16, Tri-Alloy (Cu/Sn/Zn) plated (.0001" min)
Nut Retention Spring (Plugs):	Beryllium Copper per ASTM B196, un-plated
Mounting Nut (Bulkhead Jacks):	Brass per ASTM B16, Nickel plated per SAE-AMS2423 (.0001" min)
Lock Washer (Bulkhead Jacks):	Steel, Zinc plated (.0001" min)

* All Gold plated parts include a .00005" minimum Nickel under plated barrier layer

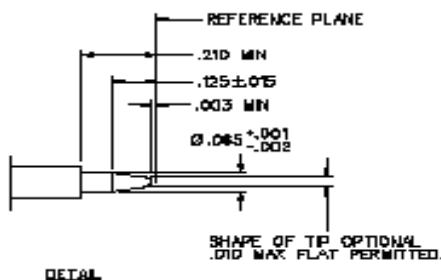
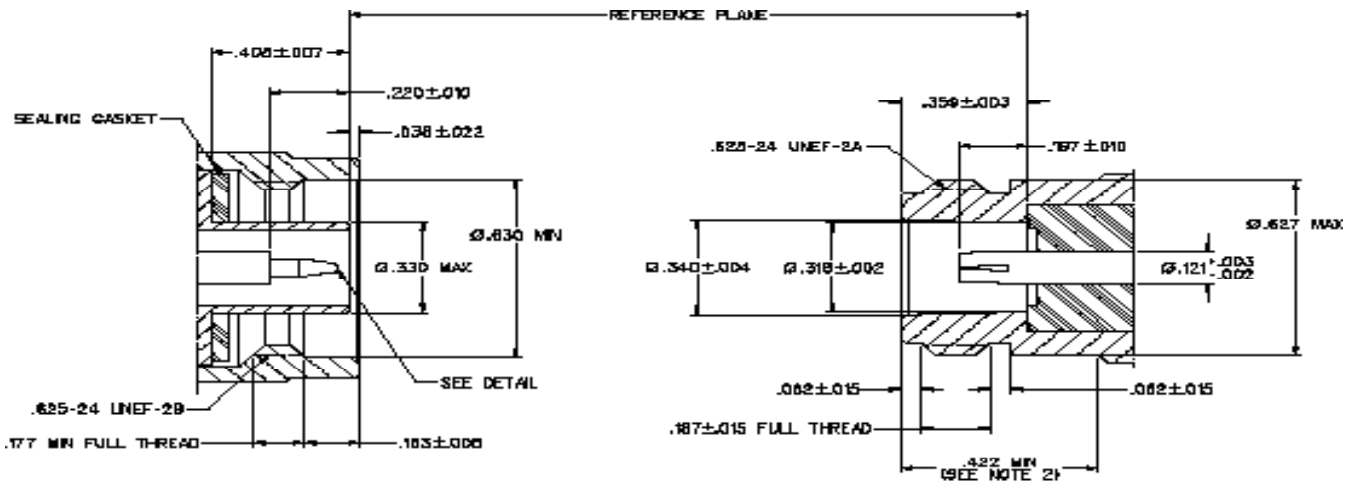

NOTES:

1. THIS INTERFACE SHALL MEET THE GAUGE REQUIREMENTS AS SPECIFIED IN MIL-PRF-39012/18 AND /20.

2. CLEARANCE FOR MATING CONNECTOR COUPLING NUT.

Straight Solder Type Plug – With Solder Contact

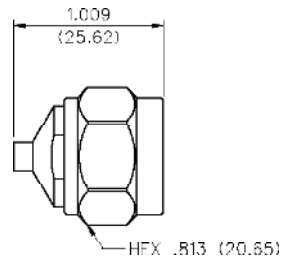

Cable Type	Gold Plated
RG-405	138-4693-001*
RG-402	138-4694-001*
RG-401	138-4696-001*

Assembly instructions page 246.

* Tri-Alloy plated coupling nut

Straight Solder Type Plug – Captivated Solderless Contact

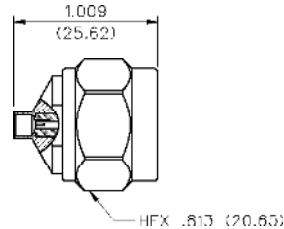

Cable Type	Gold Plated
RG-405	138-4693-011*
RG-402	138-4694-011*
RG-401	138-4696-011*

Assembly instructions page 247.

* Tri-Alloy plated coupling nut

Straight Solder Type Bulkhead Jack – With Solder Contact

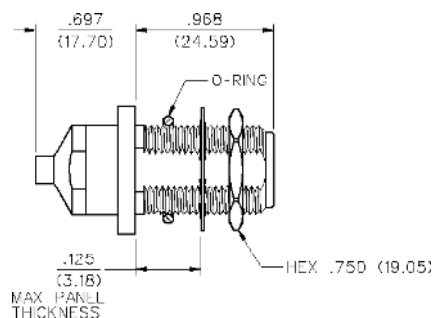

Cable Type	Gold Plated
RG-405	138-4593-401*
RG-402	138-4594-401*
RG-401	138-4596-401*

Assembly instructions page 250.

* Tri-Alloy plated bulkhead jack body

Mounting hole layout figure 5 page 194.

For more information, please contact customer service at (507) 833-8822 or (800) 247-8256 • cinch.com

Illustrations are shown in inches (millimeters).

Flexible Cable

Straight Crimp Type Plug – Solder or Crimp Contact



Cable Type	Tri-Alloy Plated	Figure
RG-161, 174, 188, 316	138-4403-007	1
RG-188 DS, RG-316 DS	138-4404-007	1
RG-58, 141, 303	138-4407-007	2
RG-55, 142, 223, 400	138-4408-007	2
RG-8, 213	138-4416-007	3
RG-9, 214	138-4418-007	3
LMR-400, BELDEN 9913	138-4449-007	3

Assembly instructions page 242 and 243.
 * Tri-Alloy plated coupling nut

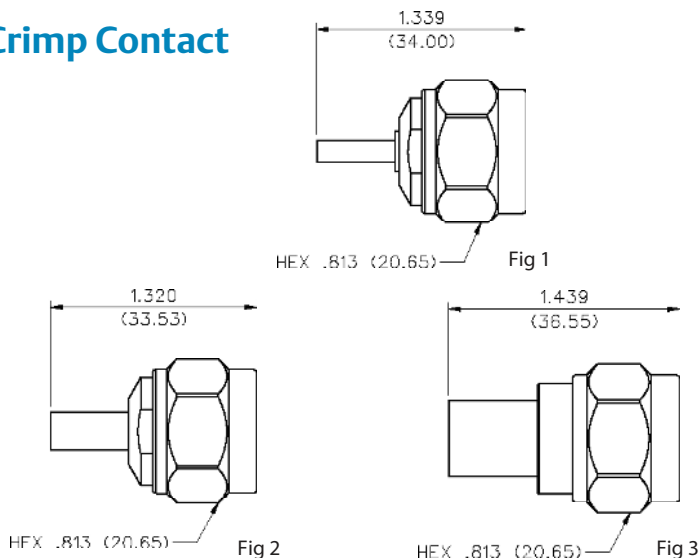

Right Angle Crimp Type Plug – Captivated Contact



Cable Type	Tri-Alloy Plated	Figure	"A"	"B"
RG-161, 174, 188, 316	138-4403-107	1	1.227 (31.17)	0.977 (24.82)
RG-188 DS, RG-316 DS	138-4404-107	1	1.227 (31.17)	0.977 (24.82)
RG-58, 141, 303	138-4407-107	2	1.253 (31.83)	1.003 (25.48)
RG-55, 142, 223, 400	138-4408-107	2	1.253 (31.83)	1.003 (25.48)
RG-8, 213	138-4416-107	2	1.365 (34.67)	1.115 (28.32)
RG-9, 214	138-4418-107	2	1.365 (34.67)	1.115 (28.32)

Assembly instructions page 244 and 245.
 * Tri-Alloy plated coupling nut

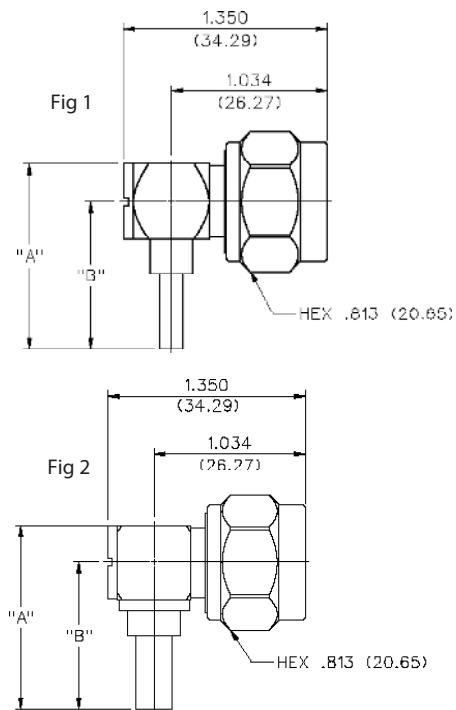

Straight Crimp Type Bulkhead Jack – Solder or Crimp Contact



Cable Type	Tri-Alloy Plated	"A"
RG-161, 174, 188, 316	138-4303-407	.943 (23.95)
RG-188 DS, RG-316 DS	138-4304-407	.943 (23.95)
RG-58, 141, 303	138-4307-407	.943 (23.95)
RG-55, 142, 223, 400	138-4308-407	.943 (23.95)
RG-8, 213	138-4316-407	.997 (25.32)
RG-9, 214	138-4318-407	.997 (25.32)
LMR-400, BELDEN 9913	138-4349-407	.997 (25.32)

Assembly instructions page 248 and 251.
 Mounting hole layout figure 9 page 194.

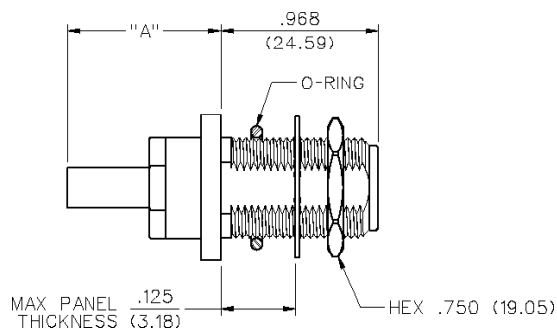

Rear Mount Bulkhead Jack Receptacle



Tri-Alloy Plated

138-4701-407

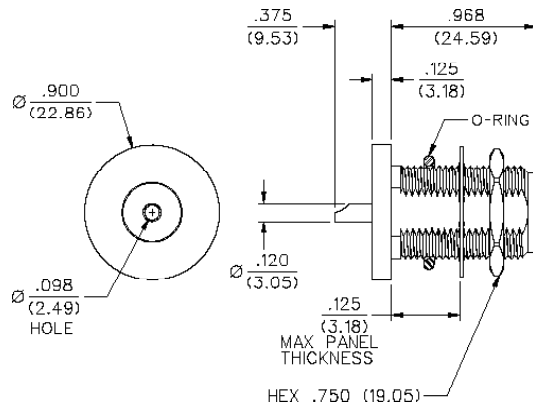

4-Hole Flange Mount Jack Receptacle – Flush Dielectric



Tri-Alloy Plated

138-4701-607

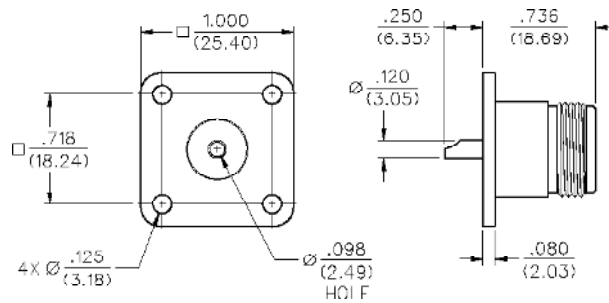

Jack to Jack Adapter



Tri-Alloy Plated

138-4901-807

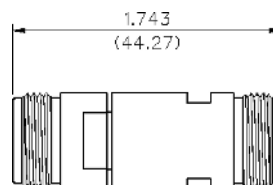

In-Series Adapters

Jack to Bulkhead Jack Adapter



Tri-Alloy Plated

138-4901-407

Mounting hole layout figure 1 page 194.

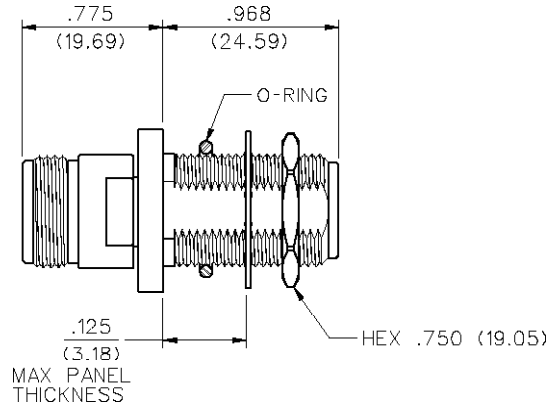

Plug to Plug Adapter



Tri-Alloy Plated

138-4901-817

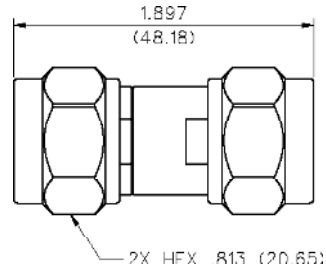

Shielded Cable Terminations

50 Ohm Connectors	
Specifications.....	154
Semi-Rigid & Flexible Cable	155
PC Mount.....	156
Other Information	
Assembly Tools	185
Capabilities.....	190
Cable Information	192
Assembly Instruction	193
Mounting Hole Layouts	194
Numerical Index	274
Competitor Cross Reference	280

3	MMCX Connectors
13	MCX Connectors
39	SMK Connectors
45	SMA Connectors
103	SMB Connectors
131	SMC Connectors
137	SMP Connectors
145	Type N Connectors
153	Shielded Cable Terminations
157	Between-Series Adapters
161	Fixed Length Cable Assemblies
173	Ultra Miniature Connectors (UMC)
181	kwiQMate™ Connectors
185	Tools
193	Assembly Instructions
257	Electronic Hardware
274	Index

While every precaution has been taken to ensure accuracy and completeness herein, Cinch Connectivity Solutions assumes no responsibility, and disclaims all liability for damages resulting from use of this information or for any errors or omissions. Specifications subject to change without notice.

Specifications

Electrical Specifications

Engagement Design:	Impedance: 29 ohms
Frequency Range:	0 - 2 GHz
Working Voltage:	300 VRMS†
Dielectric Withstanding Voltage:	2000 VDC†
Contact Resistance:	Center Contact: 6 milliohms Outer conductor: 2.5 milliohms

Mechanical Specifications

Insertion Force:	Inner conductor: 32 oz. max. 2 oz. min. Outer conductor: 48 oz. max. 6 oz. min.
Durability:	250 cycles

Environmental Ratings

Temperature Range:	-65° C to + 85° C
Corrosion:	Salt spray, 24 hours
Shock:	Method 213, Test Condition B, MIL-STD-202
Vibration:	Method 204, Test Condition B, MIL-STD-202

Material Specifications

Contact:	Beryllium copper per QQ-C-533/530
Insulator Material:	TFE Fluorocarbon per L-P-403
Finish:	Center Contact and Body: Gold

SHIELDED TEST JACK INTERFACE -
TYPICAL PROBE TYPE

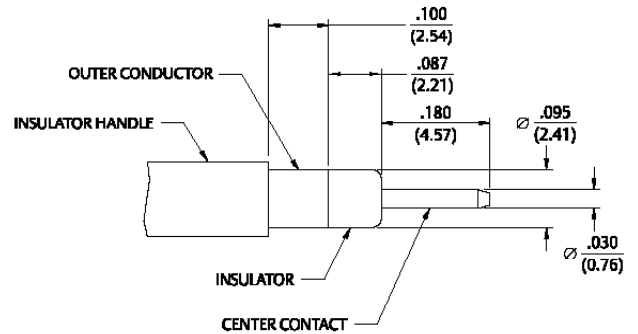
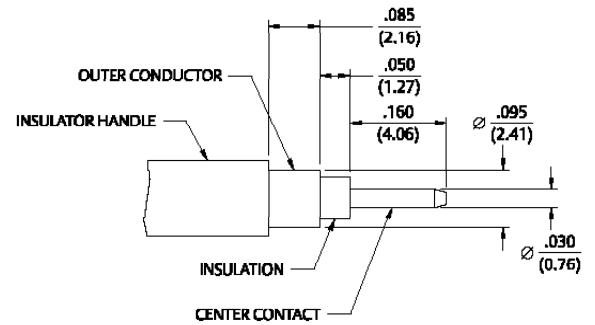

Flexible Cable – Straight Crimp Type



Cable Type	Gold Plated	Nickel Plated
RG-161/U, 174, 179, 187, 188, 316	142-0003-201	142-0003-206
RG-316 DS, RG-188 DS	142-0004-201	142-0004-206

Assembly instructions page 252. Mounting hole layout figure 3 page 194.

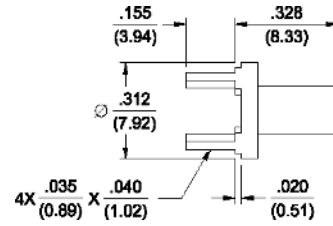

Flexible Cable – Straight Crimp Type



Cable Type	Gold Plated	Nickel Plated	"A"
RG-178/U, 196	142-0002-221	142-0002-226	.110 (2.79)
RG-316/U, 188, 174, 161, 179, 187	142-0003-231	142-0003-236	.155 (3.94)
	142-0003-241	142-0003-246	.110 (2.79)
RG-316 DS, 188 DS	142-0004-211	142-0004-216	.155 (3.94)
	142-0004-221	142-0004-226	.110 (2.79)

Assembly instructions page 252. Mounting hole layout figure 14 page 195.

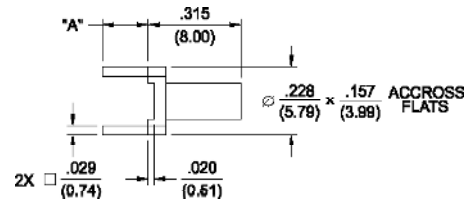

Flexible Cable – Right Angle Crimp Type

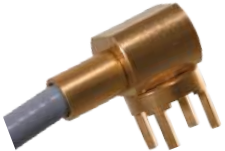

Cable Type	Gold Plated	Nickel Plated
RG-161/U, 174, 179, 187, 188, 316	142-0003-301	142-0003-306
RG-316 DS, RG-188 DS	142-0004-301	142-0004-306

Assembly instructions page 252. Mounting hole layout figure 3 page 194.

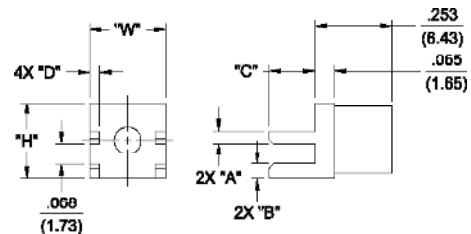
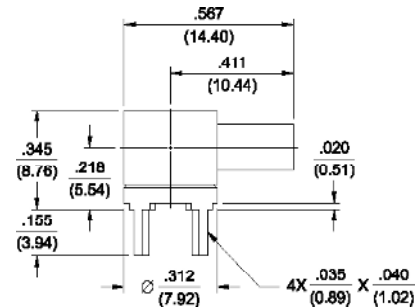

Cable Type	Gold Plated	Board Thickness	"A"	"B"	"C"	"D"	"H"	"W"
.086 Semi-Rigid	142-0093-801	0.062 (1.57)	0.068 (1.73)	0.046 (1.42)	0.150 (3.81)	0.032 (0.81)	0.250 (6.35)	0.250 (6.35)
.141 Semi-Rigid	142-0094-801	0.062 (1.57)	0.068 (1.73)	0.070 (1.78)	0.187 (4.77)	0.040 (1.02)	0.312 (7.92)	0.375 (9.52)
.250 Semi-Rigid	142-0096-801	0.062 (1.57)	0.068 (1.73)	0.053 (1.35)	0.187 (4.77)	0.050 (1.27)	0.312 (7.92)	0.375 (9.52)

Assembly instructions page 253.

For more information, please contact customer service at (507) 833-8822 or (800) 247-8256 • cinch.com

Illustrations are shown in inches (millimeters).

Flexible Cable & PC Mount

Flexible Cable – Straight Crimp Type End Launch

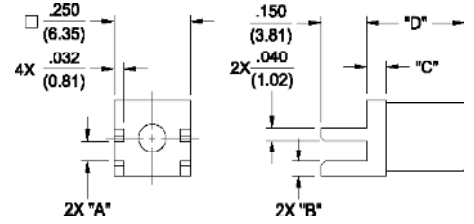

Cable Type	Gold Plated	Board Thickness	"A"	"B"	"C"	"D"
RG-316/U, 188, 174, 161, 179, 187	142-0003-801	0.062 (1.57)	0.068 (1.73)	0.046 (1.02)	0.055 (1.40)	0.310 (7.87)
RG-316 DS, 188 DS, 179 DS, 187 DS	142-0004-801	0.062 (1.57)	0.068 (1.73)	0.046 (1.02)	0.065 (1.65)	0.320 (8.13)
RG-58/U, 141, 303	142-0007-801	0.062 (1.57)	0.068 (1.73)	0.037 (1.65)	0.065 (1.65)	0.320 (8.13)
RG-142/U, 55, 223, 400	142-0008-801	0.062 (1.57)	0.068 (1.73)	0.037 (1.65)	0.065 (1.65)	0.320 (8.13)
RG-178/U, 196	142-0002-811	0.047 (1.19)	0.053 (1.35)	0.065 (1.65)	0.065 (1.65)	0.320 (8.13)
RG-316/U, 188, 174, 161, 179, 187	142-0003-811	0.047 (1.19)	0.053 (1.35)	0.061 (1.55)	0.065 (1.65)	0.320 (8.13)
RG-316 DS, 188 DS, 179 DS, 187 DS	142-0004-811	0.047 (1.19)	0.053 (1.35)	0.061 (1.55)	0.065 (1.65)	0.320 (8.13)
RG-58/U, 141, 303	142-0007-811	0.047 (1.19)	0.053 (1.35)	0.052 (1.32)	0.065 (1.65)	0.320 (8.13)
RG-142/U, 55, 223, 400	142-0008-811	0.047 (1.19)	0.053 (1.35)	0.052 (1.32)	0.065 (1.65)	0.320 (8.13)

Assembly instructions page 253.

Flexible Cable – Straight Crimp Type Surface Mount End Launch



Cable Type	Gold Plated
RG-178/U, 196	142-0002-821

Recommended land pattern figure 12 page 194.
Assembly instructions page 254.

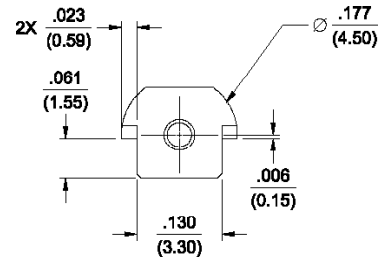

Horizontal



Gold Plated
129-0701-302

Mounting hole layout figure 15 page 195.

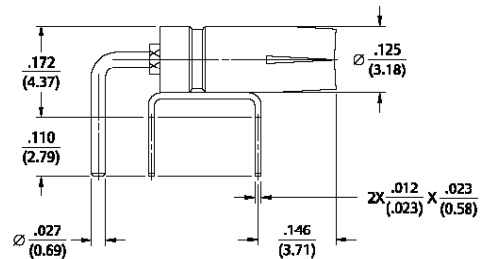

Vertical



Gold Plated
129-0701-202

Mounting hole layout figure 16 page 195.

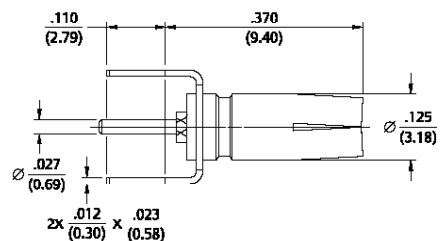

Between-Series Adapters

SMA to SMB	160
SMA to MCX.....	160
SMA to MMCX.....	160
Other Information	
Assembly Tools	185
Capabilities	190
Cable Information	192
Assembly Instruction.....	193
Mounting Hole Layouts.....	194
Numerical Index	274
Competitor Cross Reference	280

3	MMCX Connectors
13	MCX Connectors
39	SMK Connectors
45	SMA Connectors
103	SMB Connectors
131	SMC Connectors
137	SMP Connectors
145	Type N Connectors
153	Shielded Cable Terminations
157	Between-Series Adapters
161	Fixed Length Cable Assemblies
173	Ultra Miniature Connectors (UMC)
181	kwiQMate™ Connectors
185	Tools
193	Assembly Instructions
257	Electronic Hardware
274	Index

While every precaution has been taken to ensure accuracy and completeness herein, Cinch Connectivity Solutions assumes no responsibility, and disclaims all liability for damages resulting from use of this information or for any errors or omissions. Specifications subject to change without notice.

SMA to SMB

SMA Plug to SMB Jack Adapter



Gold Plated

134-1012-011

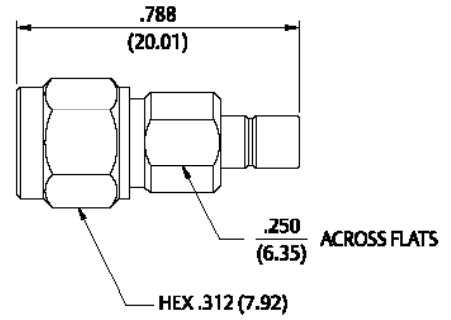

SMA Plug to SMB Plug Adapter



Gold Plated

134-1012-021

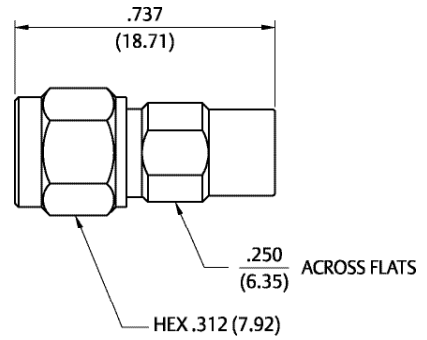

SMA Jack to SMB Plug Adapter



Gold Plated

134-1012-041

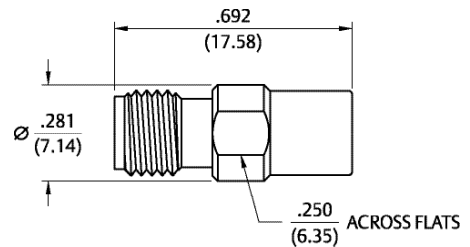

SMA Plug to MCX Jack Adapter



Gold Plated
134-1018-001

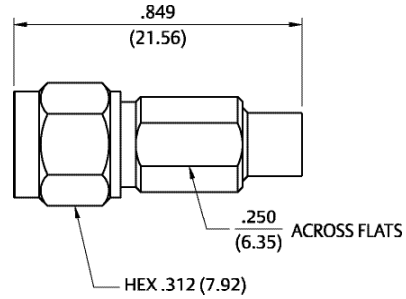

SMA Plug to MCX Plug Adapter



Gold Plated
134-1018-011

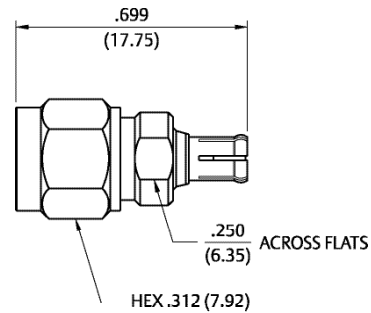

SMA Jack to MCX Jack Adapter



Gold Plated
134-1018-021

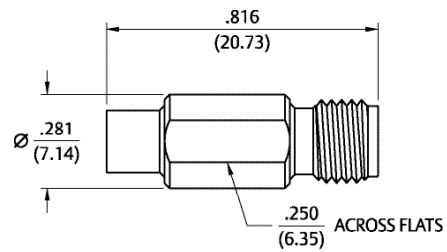

SMA Jack to MCX Plug Adapter



Gold Plated
134-1018-031

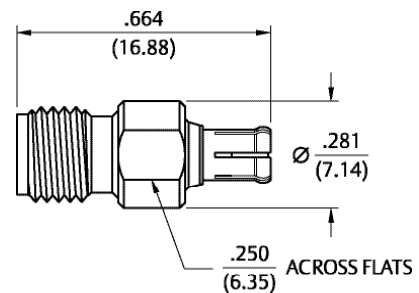

For more information, please contact customer service at (507) 833-8822 or (800) 247-8256 • cinch.com
Illustrations are shown in inches (millimeters).

SMA to MMCX

SMA Plug to MMCX Jack Adapter



Gold Plated
134-1019-151

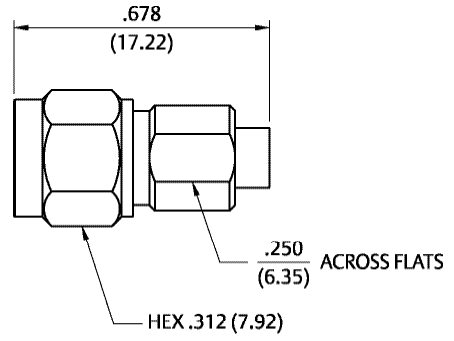

SMA Plug to MMCX Plug Adapter



Gold Plated
134-1019-161

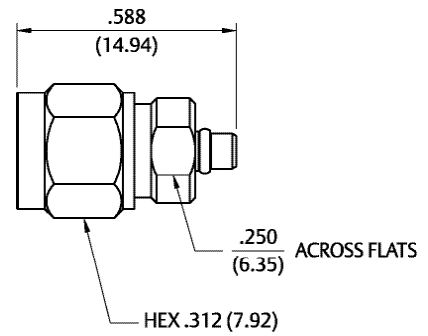

SMA Jack to MMCX Jack Adapter



Gold Plated
134-1019-171

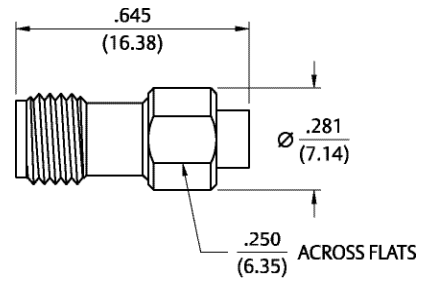

SMA Jack to MMCX Plug Adapter



Gold Plated
134-1019-181

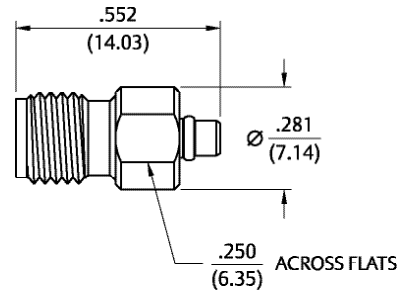

Fixed Length Cable Assemblies

Specification	162
MMCX to MMCX	163
MMCX to SMA.....	163
MCX to MCX	164
SMA to SMA.....	165
SMB to SMB.....	168
Type N to Type N.....	170
BNC to BNC.....	170
75 Ohm to 75 Ohm BNC.....	171
SMA to BNC	171
SMA to Type N.....	171
QMA to QMA.....	172
BNC to BNC.....	170
Other Information	
Assembly Tools	185
Capabilities	190
Cable Information	192
Assembly Instruction.....	193
Mounting Hole Layouts	194
Numerical Index	274
Competitor Cross Reference	280

3	MMCX Connectors
13	MCX Connectors
39	SMK Connectors
45	SMA Connectors
103	SMB Connectors
131	SMC Connectors
137	SMP Connectors
145	Type N Connectors
153	Shielded Cable Terminations
157	Between-Series Adapters
161	Fixed Length Cable Assemblies
173	Ultra Miniature Connectors (UMC)
181	kwiQMAt[™] Connectors
185	Tools
193	Assembly Instructions
257	Electronic Hardware
274	Index

While every precaution has been taken to ensure accuracy and completeness herein, Cinch Connectivity Solutions assumes no responsibility, and disclaims all liability for damages resulting from use of this information or for any errors or omissions. Specifications subject to change without notice.

Specifications

Electrical Ratings

Electrical ratings of a cable assembly are determined by the limiting connector type and cable size.

Connector	Cable	Connector Impedance (Ohms)	Frequency (GHz)	Dielectric With-standing Voltage (VRMS)	Working Voltage (VRMS)
MMCX	RG-178	50	6	500 Vms	170 Vms
	RG-316	50	6	500 Vms	170 Vms
MCX	RG-178	50	6	750 Vms	250 Vms
	RG-316	50	6	1000 Vms	335 Vms
	RG-316DS	50	6	1000 Vms	335 Vms
MCX 75 Ohm	RG-179	75	6	1000 Vms	335 Vms
	BELDEN 735A	75	6	1000 Vms	335 Vms
SMA	RG-178	50	12.4	500 Vms	170 Vms
	RG-316	50	12.4	750 Vms	250 Vms
	RG-316DS	50	12.4	750 Vms	250 Vms
	RG-58	50	12.4	1000 Vms	335 Vms
	RG-142	50	12.4	1000 Vms	335 Vms
	Hand-Formable .086	50	26.5	1000 Vms	335 Vms
	Hand-Formable .141	50	26.5	1500 Vms	500 Vms
SMB	RG-178	50	4	750 Vms	250 Vms
	RG-316	50	4	1000 Vms	335 Vms
SMB Mini 75 Ohm	RG-179	75	2	1000 Vms	335 Vms
	RG-179DS	75	2	1000 Vms	335 Vms
	BELDEN 735A	75	2	1000 Vms	335 Vms
BNC	RG-58	50	4	1500 Vms	500 Vms
	BELDEN 8218	50	4	1500 Vms	500 Vms
	RG-59	50	4	1500 Vms	500 Vms
	RG-59 PLENUM	50	4	1500 Vms	500 Vms
BNC 75 Ohm	BELDEN 8218	75	3	1500 Vms	500 Vms
	RG-59	75	3	1500 Vms	500 Vms
	BELDEN 8281	75	3	1500 Vms	500 Vms
	COMM SCOPE 735	75	3	1500 Vms	500 Vms
	BELDEN 735A	75	3	1500 Vms	500 Vms
	BELDEN 734A	75	3	1500 Vms	500 Vms
	BELDEN 1694A	75	3	1500 Vms	500 Vms
N	RG-58	50	11	1500 Vms	500 Vms
	RG-142	50	11	1500 Vms	500 Vms
	RG-8	50	11	1500 Vms	500 Vms
	RG-213	50	11	1500 Vms	500 Vms

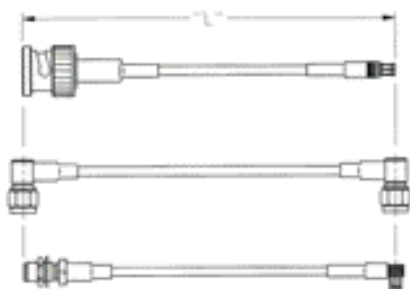

Emerson Connectivity Solutions cable length applies to the end of straight connectors. The length is applied to the vertical centroid of right angle connectors.

MMCX Straight Plug to MMCX Straight Plug



Part No.	Cable Type	Cable Length	Connector A	Connector B
415-0066-006	RG-176	6"	135-3402-001	135-3402-001
415-0066-012	RG-178	12"	135-3402-001	135-3402-001
415-0066-018	RG-178	18"	135-3402-001	135-3402-001
415-0066-024	RG-178	24"	135-3402-001	135-3402-001

Part No.	Cable Type	Cable Length	Connector A	Connector B
415-0067-006	RG-316	6"	135-3403-001	135-3403-001
415-0067-012	RG-316	12"	135-3403-001	135-3403-001
415-0067-018	RG-316	18"	135-3403-001	135-3403-001
415-0067-024	RG-316	24"	135-3403-001	135-3403-001

MMCX Right Angle Plug to MMCX Right Angle Plug



Part No.	Cable Type	Cable Length	Connector A	Connector B
415-0068-006	RG-178	6"	135-3402-101	135-3402-101
415-0068-012	RG-178	12"	135-3402-101	135-3402-101
415-0068-018	RG-178	18"	135-3402-101	135-3402-101
415-0068-024	RG-178	24"	135-3402-101	135-3402-101

Part No.	Cable Type	Cable Length	Connector A	Connector B
415-0069-006	RG-316	6"	135-34	135-3403-101
415-0069-012	RG-316	12"	135-3403-101	135-3403-101
415-0069-018	RG-316	18"	135-3403-101	135-3403-101
415-0069-024	RG-316	24"	135-3403-101	135-3403-101

MMCX Straight Plug to SMA Straight Bulkhead Jack



Part No.	Cable Type	Cable Length	Connector A	Connector B
415-0070-006	RC -178	6"	135-3402-001	142-0302-431
415-0070-012	RG-178	12"	135-3402-001	142-0302-431
415-0070-018	RG-178	18"	135-3402-001	142-0302-431
415-0070-024	RG-178	24"	135-3402-001	142-0302-431
415-0070-036	RG-178	36"	135-3402-001	142-0302-431

Part No.	Cable Type	Cable Length	Connector A	Connector B
415-0071-006	RC -316	6"	135-3403-001	142-0303-411
415-0071-012	RG-316	12"	135-3403-001	142-0303-411
415-0071-018	RG-316	18"	135-3403-001	142-0303-411
415-0071-024	RG-316	24"	135-3403-001	142-0303-411
415-0071-036	RG-316	36"	135-3403-001	142-0303-411

MMCX Right Angle Plug to SMA Straight Bulkhead Jack



Part No.	Cable Type	Cable Length	Connector A	Connector B
415-0072-006	RG-178	6"	135-3402-101	142-0302-431
415-0072-012	RG-178	12"	135-3402-101	142-0302-431
415-0072-018	RG-178	18"	135-3402-101	142-0302-431
415-0072-024	RG-178	24"	135-3402-101	142-0302-431
415-0072-036	RG-178	36"	135-3402-101	142-0302-431

Part No.	Cable Type	Cable Length	Connector A	Connector B
415-0073-006	RG-316	6"	135-3403-101	142-0303-411
415-0073-012	RG-316	12"	135-3403-101	142-0303-411
415-0073-018	RG-316	18"	135-3403-101	142-0303-411
415-0073-024	RG-316	24"	135-3403-101	142-0303-411
415-0073-036	RG-316	36"	135-3403-101	142-0303-411

For more information, please contact customer service at (507) 833-8822 or (800) 247-8256 • cinch.com

Illustrations are shown in inches (millimeters).

MCX Straight Plug to MCX Straight Plug



Part No.	Cable Type	Cable Length	Connector A	Connector B
415-0014-006	RG -178	6"	133-3402-021	133-3402-021
415-0014-012	RG -176	12"	133-3402-021	133-3402-021
415-0014-018	RG -178	18"	133-3402-021	133-3402-021
415-0014-024	RG -178	24"	133-3402-021	133-3402-021
415-0014-030	RG -178	30"	133-3402-021	133-3402-021
415-0014-036	RG -178	36"	133-3402-021	133-3402-021
415-0018-006	RG -316	6"	133-3403-001	133-3403-001
415-0018-012	RG -316	12"	133-3403-001	133-3403-001
415-0018-018	RG -316	18"	133-3403-001	133-3403-001

Part No.	Cable Type	Cable Length	Connector A	Connector B
415-0018-024	RG -316	24"	133-3403-001	133-3403-001
415-0018-030	RG -316	30"	133-3403-001	133-3403-001
415-0018-036	RG -316	36"	133-3403-001	133-3403-001
415-0020-006	RG -316	6"	133-3404-001	133-3404-001
415-0020-012	RG-316DS	12"	133-3404-001	133-3404-001
415-0020-018	RG-316DS	18"	133-3404-001	133-3404-001
415-0020-024	RG-316DS	24"	133-3404-001	133-3404-001
415-0020-030	RG-316DS	30"	133-3404-001	133-3404-001
415-0020-036	RG-316DS	36"	133-3404-001	133-3404-001

MCX Straight Plug to MCX Straight Bulkhead Jack



Part No.	Cable Type	Cable Length	Connector A	Connector B
415-0016-006	RG -316	6"	133-3403-001	133-3303-401
415-0016-012	RG -316	12"	133-3403-001	133-3303-401
415-0016-018	RG -316	18"	133-3403-001	133-3303-401

Part No.	Cable Type	Cable Length	Connector A	Connector B
415-0016-024	RG -316	24"	133-3403-001	133-3303-401
415-0016-030	RG -316	30"	133-3403-001	133-3303-401
415-0016-036	RG -316	36"	133-3403-001	133-3303-401

MCX Straight Plug to MCX Right Angle Plug



Part No.	Cable Type	Cable Length	Connector A	Connector B
415-0017-006	RG -316	6"	133-3403-001	133-3403-101
415-0017-012	RG -316	12"	133-3403-001	133-3403-101
415-0017-018	RG -316	18"	133-3403-001	133-3403-101

Part No.	Cable Type	Cable Length	Connector A	Connector B
415-0017-024	RG -316	24"	133-3403-001	133-3403-101
415-0017-030	RG -316	30"	133-3403-001	133-3403-101
415-0017-036	RG -316	36"	133-3403-001	133-3403-101

MCX Right Angle Plug to MCX Right Angle Plug



Part No.	Cable Type	Cable Length	Connector A	Connector B
415-0015-006	RG -178	6"	133-3402-101	133-3402-101
415-0015-012	RG -178	12"	133-3402-101	133-3402-101
415-0015-018	RG -178	18"	133-3402-101	133-3402-101
415-0015-024	RG -178	24"	133-3402-101	133-3402-101
415-0015-030	RG -178	30"	133-3402-101	133-3402-101
415-0015-036	RG -178	36"	133-3402-101	133-3402-101
415-0012-006	RG -316	6"	133-3403-101	133-3403-101

Part No.	Cable Type	Cable Length	Connector A	Connector B
415-0021-006	RG-316DS	6"	133-3404-101	133-3404-101
415-0021-012	RG-316DS	12"	133-3404-101	133-3404-101
415-0021-018	RG-316DS	18"	133-3404-101	133-3404-101
415-0021-024	RG-316DS	24"	133-3404-101	133-3404-101
415-0021-030	RG-316DS	30"	133-3404-101	133-3404-101
415-0021-036	RG-316DS	36"	133-3404-101	133-3404-101

MCX 75 Ohm Straight Plug to MCX 75 Ohm Straight Plug



Part No.	Cable Type	Cable Length	Connector A	Connector B	Part No.	Cable Type	Cable Length	Connector A	Connector B
415-0022-006	RG -179	6"	133-8433-001	133-8433-001	415-0023-006	Belden 735A	6"	133-8445-001	133-8445-001
415-0022-012	RG -179	12"	133-8433-001	133-8433-001	415-0023-012	Belden 735A	12"	133-8445-001	133-8445-001
415-0022-018	RG -179	18"	133-8433-001	133-8433-001	415-0023-018	Belden 735A	18"	133-8445-001	133-8445-001
415-0022-024	RG-179	24"	133-8433-001	133-8433-001	415-0023-024	Belden 735A	24"	133-8445-001	133-8445-001
415-0022-030	RG -179	30"	133-8433-001	133-8433-001	415-0023-030	Belden 735A	30"	133-8445-001	133-8445-001
415-0022-036	RG -179	36"	133-8433-001	133-8433-001	415-0023-036	Belden 735A	36"	133-8445-001	133-8445-001

MCX 75 Ohm Right Angle Plug to MCX 75 Ohm Right Angle Plug



Part No.	Cable Type	Cable Length	Connector A	Connector B	Part No.	Cable Type	Cable Length	Connector A	Connector B
415-0024-006	Belden 735A	6"	133-8445-101	133-8445-101	415-0024-024	Belden 735A	24"	133-8445-101	133-8445-101
415-0024-012	Belden 735A	12"	133-8445-101	133-8445-101	415-0024-030	Belden 735A	30"	133-8445-101	133-8445-101
415-0024-018	Belden 735A	18"	133-8445-101	133-8445-101	415-0024-036	Belden 735A	36"	133-8445-101	133-8445-101

SMA Straight Plug to SMA Straight Plug



Part No.	Cable Type	Cable Length	Connector A	Connector B	Part No.	Cable Type	Cable Length	Connector A	Connector B
415-0025-006	RG -178	6"	142-0402-011	142-0402-011	415-0033-018	RG-316DS	18"	142-0404-011	142-0404-011
415-0025-012	RG -178	12"	142-0402-011	142-0402-011	415-0033-024	RG-316DS	24"	142-0404-011	142-0404-011
415-0025-018	RG -178	18"	142-0402-011	142-0402-011	415-0033-036	RG-316DS	36"	142-0404-011	142-0404-011
415-0025-024	RG -178	24"	142-0402-011	142-0402-011	415-0033-048	RG-316DS	48"	142-0404-011	142-0304-411
415-0025-036	RG -178	36"	142-0402-011	142-0402-011	415-0038-012	RG -58	12"	142-0407-011	142-0307-411
415-0025-048	RG -178	48"	142-0402-011	142-0402-011	415-0038-024	RG -58	24"	142-0407-011	142-0307-411
415-0029-006	RG -316	6"	142-0403-011	142-0403-011	415-0038-036	RG -58	36"	142-0407-011	142-0307-411
415-0029-012	RG -316	12"	142-0403-011	142-0403-011	415-0038-048	RG -58	48"	142-0407-011	142-0307-411
415-0029-018	RG -316	18"	142-0403-011	142-0403-011	415-0038-060	RG-58	60"	142-0407-011	142-0307-411
415-0029-024	RG -316	24"	142-0403-011	142-0403-011	415-0043-012	RG-142	12"	142-0408-011	142-0308-411
415-0029-036	RG -316	36"	142-0403-011	142-0403-011	415-0043-024	RG-142	24"	142-0408-011	142-0308-411
415-0029-048	RG -316	48"	142-0403-011	142-0403-011	415-0043-036	RG-142	36"	142-0408-011	142-0308-411
415-0033-006	RG -316DS	6"	142-0404-011	142-0404-011	415-0043-048	RG -142	48"	142-0408-011	142-0308-411
415-0033-012	RG -316DS	12"	142-0404-011	142-0404-011	415-0043-060	RG-142	60"	142-0408-011	142-0308-411

For more information, please contact customer service at (507) 833-8822 or (800) 247-8256 • cinch.com

Illustrations are shown in inches (millimeters).

Hand Formable SMA Straight Plug to SMA Straight Plug



Part No.	Cable Type	Cable Length	Connector A	Connector B
415-0081-003	Hand Formable .086	3"	142-0693-001	142-0693-001
415-0081-004	Hand Formable .086	4"	142-0693-001	142-0693-001
415-0081-005	Hand Formable .086	5"	142-0693-001	142-0693-001
415-0081-006	Hand Formable .086	6"	142-0693-001	142-0693-001
415-0081-007	Hand Formable .086	7"	142-0693-001	142-0693-001

Part No.	Cable Type	Cable Length	Connector A	Connector B
415-0081-008	Hand Formable .086	8"	142-0693-001	142-0693-001
415-0081-012	Hand Formable .086	12"	142-0693-001	142-0693-001
415-0081-018	Hand Formable .086	18"	142-0693-001	142-0693-001
415-0081-024	Hand Formable .086	24"	142-0693-001	142-0693-001

Hand Formable SMA Straight Plug to SMA Straight Plug



Part No.	Cable Type	Cable Length	Connector A	Connector B
415-0082-003	Hand Formable .141	3"	142-0694-001	142-0694-001
415-0082-004	Hand Formable .141	4"	142-0694-001	142-0694-001
415-0082-005	Hand Formable .141	5"	142-0694-001	142-0694-001
415-0082-006	Hand Formable .141	6"	142-0694-001	142-0694-001
415-0082-007	Hand Formable .141	7"	142-0694-001	142-0694-001

Part No.	Cable Type	Cable Length	Connector A	Connector B
415-0082-008	Hand Formable .141	8"	142-0694-001	142-0694-001
415-0082-012	Hand Formable .141	12"	142-0694-001	142-0694-001
415-0082-018	Hand Formable .141	18"	142-0694-001	142-0694-001
415-0082-024	Hand Formable .141	24"	142-0694-001	142-0694-001

SMA Straight Plug to SMA Straight Bulkhead Jack



Part No.	Cable Type	Cable Length	Connector A	Connector B
415-0031-006	RG-316	6"	142-0403-011	142-0303-411
415-0031-012	RG-316	12"	142-0403-011	142-0303-411
415-0031-018	RG-316	18"	142-0403-011	142-0303-411
415-0031-024	RG-316	24"	142-0403-011	142-0303-411
415-0031-036	RG-316	36"	142-0403-011	142-0303-411
415-0031-048	RG-316	48"	142-0403-011	142-0303-411
415-0035-006	RG-316 DS	6"	142-0404-011	142-0304-411
415-0035-012	RG-316 DS	12"	142-0404-011	142-0304-411
415-0035-018	RG-316 DS	18"	142-0404-011	142-0304-411
415-0035-024	RG-316 DS	24"	142-0404-011	142-0304-411
415-0035-036	RG-316 DS	36"	142-0404-011	142-0304-411

Part No.	Cable Type	Cable Length	Connector A	Connector B
415-0035-048	RG-316DS	48"	142-0404-011	142-0304-411
415-0040-012	RG-58	12"	142-0407-011	142-0307-411
415-0040-024	RG-58	24"	142-0407-011	142-0307-411
415-0040-036	RG-58	36"	142-0407-011	142-0307-411
415-0040-048	RG-58	48"	142-0407-011	142-0307-411
415-0040-060	RG-58	60"	142-0407-011	142-0307-411
415-0045-012	RG-142	12"	142-0408-011	142-0308-411
415-0045-024	RG-142	24"	142-0408-011	142-0308-411
415-0045-036	RG-142	36"	142-0408-011	142-0308-411
415-0045-048	RG-142	48"	142-0408-011	142-0308-411
415-0045-060	RG-142	60"	142-0408-011	142-0308-411

SMA Straight Plug to SMA Right Angle Plug



Part No.	Cable Type	Cable Length	Connector A	Connector B
415-0026-006	RG-178	6"	142-0402-011	142-0402-101
415-0026-012	RG-176	12"	142-0402-011	142-0402-101
415-0026-016	RG-178	18"	142-0402-011	142-0402-101
415-0026-024	RG-178	24"	142-0402-011	142-0402-101
415-0026-036	RG-178	36"	142-0402-011	142-0402-101
415-0026-048	RG-178	48"	142-0402-011	142-0402-101
415-0030-006	RG-316	6"	142-0403-011	142-0403-101
415-0030-012	RG-316	12"	142-0403-011	142-0403-101
415-0030-018	RG-316	18"	142-0403-011	142-0403-101
415-0030-024	RG-316	24"	142-0403-011	142-0403-101
415-0030-036	RG-316	36"	142-0403-011	142-0403-101
415-0030-048	RG-316	48"	142-0403-011	142-0403-101

Part No.	Cable Type	Cable Length	Connector A	Connector B
415-0034-006	RG-316	6"	142-0404-011	142-0404-101
415-0034-012	RG-316	12"	142-0404-011	142-0404-101
415-0034-018	RG-316	18"	142-0404-011	142-0404-101
415-0034-024	RG-316	24"	142-0404-011	142-0404-101
415-0034-036	RG-316	36"	142-0404-011	142-0404-101
415-0034-048	RG-316	48"	142-0404-011	142-0404-101
415-0044-012	RG-142	12"	142-0408-011	142-0408-101
415-0044-024	RG-142	24"	142-0408-011	142-0408-101
415-0044-036	RG-142	36"	142-0408-011	142-0408-101
415-0044-048	RG-142	48"	142-0408-011	142-0408-101
415-0044-060	RG-142	60"	142-0408-011	142-0408-101

SMA Right Angle Plug to SMA Right Angle Plug



Part No.	Cable Type	Cable Length	Connector A	Connector B
415-0027-006	RG-178	6"	142-0402-101	142-0402-101
415-0027-012	RG-178	12"	142-0402-101	142-0402-101
415-0027-018	RG-178	18"	142-0402-101	142-0402-101
415-0027-024	RG-178	24"	142-0402-101	142-0402-101
415-0027-036	RG-178	36"	142-0402-101	142-0402-101
415-0027-048	RG-178	48"	142-0402-101	142-0402-101
415-0032-006	RG-316	6"	142-0403-101	142-0403-101
415-0032-012	RG-316	12"	142-0403-101	142-0403-101
415-0032-018	RG-316	18"	142-0403-101	142-0403-101
415-0032-024	RG-316	24"	142-0403-101	142-0403-101
415-0032-036	RG-316	36"	142-0403-101	142-0403-101
415-0032-048	RG-316	48"	142-0403-101	142-0403-101
415-0036-006	RG-316DS	6"	142-0404-101	142-0404-101
415-0036-012	RG-316DS	12"	142-0404-101	142-0404-101

Part No.	Cable Type	Cable Length	Connector A	Connector B
415-0036-018	RG-316	18"	142-0404-101	142-0404-101
415-0036-024	RG-316	24"	142-0404-101	142-0404-101
415-0036-036	RG-316	36"	142-0404-101	142-0404-101
415-0036-048	RG-316	48"	142-0404-101	142-0404-101
415-0041-012	RG-58	12"	142-0407-101	142-0407-101
415-0041-024	RG-58	24"	142-0407-101	142-0407-101
415-0041-036	RG-58	36"	142-0407-101	142-0407-101
415-0041-048	RG-58	48"	142-0407-101	142-0407-101
415-0041-060	RG-58	60"	142-0407-101	142-0407-101
415-0046-012	RG-142	12"	142-0408-101	142-0408-101
415-0046-024	RG-142	24"	142-0408-101	142-0408-101
415-0046-036	RG-142	36"	142-0408-101	142-0408-101
415-0046-048	RG-142	48"	142-0408-101	142-0408-101
415-0046-060	RG-142	60"	142-0408-101	142-0408-101

For more information, please contact customer service at (507) 833-8822 or (800) 247-8256 • cinch.com

Illustrations are shown in inches (millimeters).

SMA Right Angle Plug to SMA Straight Bulkhead Jack



Part No.	Cable Type	Cable Length	Connector A	Connector B
415-0074-006	RG-316	6"	142-0403-101	142-0303-411
415-0074-012	RG-316	12"	142-0403-101	142-0303-411
415-0074-024	RG-316	24"	142-0403-101	142-0303-411
415-0074-036	RG-316	36"	142-0403-101	142-0303-411
415-0074-048	RG-316	48"	142-0403-101	142-0303-411
415-0064-006	RG-316DS	6"	142-0404-101	142-0304-411
415-0064-012	RG-316DS	12"	142-0404-101	142-0304-411
415-0064-024	RG-316DS	24"	142-0404-101	142-0304-411

Part No.	Cable Type	Cable Length	Connector A	Connector B
415-0064-036	RG-316DS	36"	142-0404-101	142-0304-411
415-0064-048	RG-316DS	48"	142-0404-101	142-0304-411
415-0075-006	RG-142	6"	142-0406-101	142-0306-411
415-0075-012	RG-142	12"	142-0406-101	142-0306-411
415-0075-024	RG-142	24"	142-0406-101	142-0306-411
415-0075-036	RG-142	36"	142-0406-101	142-0306-411
415-0075-048	RG-142	48"	142-0406-101	142-0306-411

Straight SMA Quick-Connect Plug to Straight SMA Quick-Connect Plug



Part No.	Cable Type	Cable Length	Connector A	Connector B
415-0065-006	RG-316	6"	142-1403-001	142-1403-001
415-0065-012	RG-316	12"	142-1403-001	142-1403-001
415-0065-018	RG-316	18"	142-1403-001	142-1403-001
415-0065-024	RG-316	24"	142-1403-001	142-1403-001
415-0065-036	RG-316	36"	142-1403-001	142-1403-001
415-0065-048	RG-316	48"	142-1403-001	142-1403-001

Part No.	Cable Type	Cable Length	Connector A	Connector B
415-0076-012	RG-316DS	12"	142-1404-001	142-1404-001
415-0076-024	RG-316DS	24"	142-1404-001	142-1404-001
415-0076-036	RG-316DS	36"	142-1404-001	142-1404-001
415-0077-012	RG-142	12"	142-1408-001	142-1408-001
415-0077-024	RG-142	24"	142-1408-001	142-1408-001
415-0077-036	RG-142	36"	142-1408-001	142-1408-001

Straight SMA Quick-Connect Plug to Straight SMA Plug



Part No.	Cable Type	Cable Length	Connector A	Connector B
415-0078-012	RG-316DS	12"	142-1404-001	142-0404-011
415-0078-024	RG-316DS	24"	142-1404-001	142-0404-011
415-0078-036	RG-316DS	36"	142-1404-001	142-0404-011

Part No.	Cable Type	Cable Length	Connector A	Connector B
415-0079-012	RG-142	12"	142-1408-001	142-0408-011
415-0079-024	RG-142	24"	142-1408-001	142-0408-011
415-0079-036	RG-142	36"	142-1408-001	142-0408-011

SMB Straight Plug to SMB Straight Plug



Part No.	Cable Type	Cable Length	Connector A	Connector B
413-0003-000	RG-316	6"	131-1403-001	131-1403-001
415-0003-012	RG-316	12"	131-1403-001	131-1403-001
415-0003-018	RG-316	18"	131-1403-001	131-1403-001

Part No.	Cable Type	Cable Length	Connector A	Connector B
413-0003-024	RG-316	24"	131-1403-001	131-1403-001
415-0003-030	RG-316	30"	131-1403-001	131-1403-001
415-0003-036	RG-316	36"	131-1403-001	131-1403-001



SMB Straight Plug to SMB Right Angle Plug

Part No.	Cable Type	Cable Length	Connector A	Connector B
415-0007-006	RG-178	6"	131-3462-661	131-1462-161
415-0007-012	RG-178	12"	131-3402-001	131-1402-101
415-0007-018	RG-178	18"	131-3462-661	131-1462-161
415-0007-024	RG-178	24"	131-3462-661	131-1462-161
415-0007-030	RG-178	36"	131-3462-661	131-1462-161
415-0007-036	RG-178	36"	131-3462-661	131-1462-161
415-0002-006	RG-316	6"	131-1463-661	131-1463-161
415-0002-012	RG-316	12"	131-1463-661	131-1463-161
415-0002-018	RG-316	18"	131-1463-661	131-1463-161

Part No.	Cable Type	Cable Length	Connector A	Connector B
415-0002-024	RG-316	24"	131-1403-001	131-1403-101
415-0002-030	RG-316	30"	131-1403-001	131-1403-101
415-0002-036	RG-316	36"	131-1403-001	131-1403-101
415-0005-006	RG-316 DS	6"	131-1404-001	131-1404-101
415-0005-012	RG-316 DS	12"	131-1404-001	131-1404-101
415-0005-018	RG-316 DS	16"	131-1404-001	131-1404-101
415-0005-024	RG-316 DS	24"	131-1404-001	131-1404-101
415-0005-030	RG-316 DS	30"	131-1404-001	131-1404-101
415-0005-036	RG-316 DS	36"	131-1404-001	131-1404-101

SMB Right Angle Plug to SMB Right Angle Plug



Part No.	Cable Type	Cable Length	Connector A	Connector B
415-0001-006	RG-178	6"	131-1402-101	131-1402-101
415-0001-012	RG-178	12"	131-1402-101	131-1402-101
415-0001-018	RG-178	18"	131-1402-101	131-1402-101
415-0001-024	RG-178	24"	131-1402-101	131-1402-101
415-0001-030	RG-178	30"	131-1402-101	131-1402-101
415-0001-036	RG-178	36"	131-1402-101	131-1402-101
415-0004-006	RG-316	6"	131-1403-101	131-1403-101
415-0004-012	RG-316	12"	131-1403-101	131-1403-101
415-0004-018	RG-316	18"	131-1403-101	131-1403-101

Part No.	Cable Type	Cable Length	Connector A	Connector B
415-0004-024	RG-316	24"	131-1403-101	131-1403-101
415-0004-030	RG-316	30"	131-1403-101	131-1403-101
415-0004-036	RG-316	36"	131-1403-101	131-1403-101
415-0006-006	RG-316DS	6"	131-1404-101	131-1404-101
415-0006-012	RG-316DS	12"	131-1404-101	131-1404-101
415-0006-018	RG-316DS	18"	131-1404-101	131-1404-101
415-0006-024	RG-316DS	24"	131-1404-101	131-1404-101
415-0006-030	RG-316DS	30"	131-1404-101	131-1404-101
415-0006-036	RG-316DS	36"	131-1404-101	131-1404-101

SMB Mini-75 Ohm Straight Plug to SMB Mini-75 Ohm Straight Plug



Part No.	Cable Type	Cable Length	Connector A	Connector B
415-0008-006	RG-179	6"	131-8403-011	131-8403-011
415-0008-012	RG-179	12"	131-8403-011	131-8403-011
415-0008-018	RG-179	18"	131-6403-011	131-6403-011
415-0008-024	RG-179	24"	131-6403-011	131-6403-011
415-0008-030	RG-179	30"	131-8403-011	131-8403-011
415-0008-036	RG-179	36"	131-8403-011	131-8403-011

Part No.	Cable Type	Cable Length	Connector A	Connector B
415-0010-006	RG-179 DS	6"	131-6404-011	131-6404-011
415-0010-012	RG-179 DS	12"	131-6404-011	131-6404-011
415-0010-018	RG-179 DS	18"	131-6404-011	131-6404-011
415-0010-024	RG-179 DS	24"	131-6404-011	131-6404-011
415-0010-030	RG-179 DS	30"	131-6404-011	131-6404-011
415-0010-036	RG-179 DS	36"	131-6404-011	131-6404-011

For more information, please contact customer service at (507) 833-8822 or (800) 247-8256 • cinch.com

Illustrations are shown in inches (millimeters).

SMB Mini-75 Ohm Straight Plug to SMB Mini-75 Ohm Right Angle Plug



Part No.	Cable Type	Cable Length	Connector A	Connector B
415-0009-006	RG -179	6"	131-8403-111	131-8403-111
415-0009-012	RG -179	12"	131-8403-111	131-8403-111
415-0009-018	RG -179	18"	131-8403-111	131-8403-111
415-0009-024	RG-179	24"	131-8403-111	131-8403-111
415-0009-030	RG -179	30"	131-8403-111	131-8403-111
415-0009-036	RG -179	36"	131-8403-111	131-8403-111
415-0011-006	RG-179 DS	6"	131-8404-111	131-8404-111
415-0011-012	RG-179 DS	12"	131-8404-111	131-8404-111
415-0011-018	RG-179 DS	18"	131-8404-111	131-8404-111

Part No.	Cable Type	Cable Length	Connector A	Connector B
415-0011-024	RG-179 DS	24"	131-8404-111	131-8404-111
415-0011-030	RG-179 DS	30"	131-8404-111	131-8404-111
415-0011-036	RG-179 DS	36"	131-8404-111	131-8404-111
415-0013-006	Belden 735A	6"	131-8445-101	131-8445-101
415-0013-012	Belden 735A	12"	131-8445-101	131-8445-101
415-0013-018	Belden 735A	18"	131-8445-101	131-8445-101
415-0013-024	Belden 735A	24"	131-8445-101	131-8445-101
415-0013-030	Belden 735A	30"	131-8445-101	131-8445-101
415-0013-036	Belden 735A	36"	131-8445-101	131-8445-101

N Straight Plug to N Straight Plug



Part No.	Cable Type	Cable Length	Connector A	Connector B
415-0058-012	RG -58	12"	CPN -1	CPN -1
415-0058-024	RG -58	24"	CPN -1	CPN -1
415-0058-036	RG -58	36"	CPN -1	CPN -1
415-0058-048	RG -58	48"	CPN -1	CPN -1
415-0058-060	RG -58	60"	CPN -1	CPN -1
415-0060-012	RG -142	12"	CPN -142T	CPN -142T
415-0060-024	RG -142	24"	CPN -142T	CPN -142T
415-0060-036	RG -142	36"	CPN -142T	CPN -142T
415-0060-048	RG -142	48"	CPN -142T	CPN -142T
415-0060-060	RG -142	60"	CPN -142T	CPN -142T

Part No.	Cable Type	Cable Length	Connector A	Connector B
415-0062-012	RG-8	12"	CPN -8	CPN -8
415-0062-024	RG-8	24"	CPN -8	CPN -8
415-0062-036	RG-8	36"	CPN -8	CPN -8
415-0062-048	RG-8	48"	CPN-8	CPN-8
415-0062-060	RG-8	60"	CPN -8	CPN -8
415-0063-012	RG -213	12"	CPN -8	CPN -8
415-0063-024	RG -213	24"	CPN -8	CPN -8
415-0063-036	RG -213	36"	CPN -8	CPN -8
415-0063-048	RG -213	48"	CPN -8	CPN -8
415-0063-060	RG -213	60"	CPN -8	CPN -8

BNC Straight Plug to BNC Straight Plug



Part No.	Cable Type	Cable Length	Connector A	Connector B
415-0054-012	RG -58	12"	CPMC-88-1	CPMC-88-1
415-0054-024	RG -58	24"	CPMC-88-1	CPMC-88-1
415-0054-036	RG-58	36"	CPMC-88-1	CPMC-88-1
415-0054-048	RG -58	48"	CPMC-88-1	CPMC-88-1
415-0054-060	RG -58	60"	CPMC-88-1	CPMC-88-1
415-0057-012	RG-59	12"	CPMC-88-2	CPMC-88-2
415-0057-024	RG-59	24"	CPMC-88-2	CPMC-88-2
415-0057-036	RG-59	36"	CPMC-88-2	CPMC-88-2
415-0057-048	RG-59	48"	CPMC-88-2	CPMC-88-2

Part No.	Cable Type	Cable Length	Connector A	Connector B
415-0056-012+	Belden 8218	12"	CPMC-88-18	CPMC-88-18
415-0056-024+	Belden 8218	24"	CPMC-88-18	CPMC-88-18
415-0056-036+	Belden 8218	36"	CPMC-88-18	CPMC-88-18
415-0056-048+	Belden 8218	48"	CPMC-88-18	CPMC-88-18
415-0056-060+	Belden 8218	60"	CPMC-88-18	CPMC-88-18

+ with Heat Shrink

75 Ohm BNC Straight Plug to 75 Ohm BNC Straight Plug



Part No.	Cable Type	Cable Length	Connector A	Connector B
415-0048-012	RG -59	12"	CPMC-68-2	CPMC-68-2
415-0048-024	RG -59	24"	CPMC-68-2	CPMC-68-2
415-0048-036	RG-59	36"	CPMC-68-2	CPMC-68-2
415-0048-048	RG -59	48"	CPMC-68-2	CPMC-68-2
415-0048-060	RG -59	60"	CPMC-68-2	CPMC-68-2
415-0052-012	Belden 734A	12"	CPMC-68-35	CPMC-68-35
415-0052-024	Belden 734A	24"	CPMC-68-3	CPMC-68-35
415-0052-036	Belden 734A	36"	CPMC-68-35	CPMC-68-35
415-0052-048	Belden 734A	48"	CPMC-68-35	CPMC-68-35
415-0052-060	Belden 734A	60"	CPMC-68-35	CPMC-68-35

Part No.	Cable Type	Cable Length	Connector A	Connector B
415-0047-012	Belden 8218	12"	CPMC-68-18	CPMC-58-18
415-0047-024	Belden 8218	24"	CPMC-68-18	CPMC-68-18
415-0047-036	Belden 8218	36"	CPMC-68-18	CPMC-68-18
415-0047-048	Belden 8218	48"	CPMC-68-18	CPMC-68-18
415-0047-060	Belden 8218	60"	CPMC-68-18	CPMC-68-18
415-0049-012	Belden 8281	12"	CPMC-68-3	CPMC-68-3
415-0049-024	Belden 8281	24"	CPMC-68-3	CPMC-68-3
415-0049-036	Belden 8281	36"	CPMC-68-3	CPMC-68-3
415-0049-048	Belden 8281	48"	CPMC-68-3	CPMC-68-3
415-0049-060	Belden 8281	60"	CPMC-68-3	CPMC-68-3
415-0050-012	Comm Scope 735	12"	CPMC-68-33	CPMC-68-33
415-0050-024	Comm Scope 735	24"	CPMC-68-33	CPMC-68-33
415-0050-036	Comm Scope 735	36"	CPMC-68-33	CPMC-68-33
415-0050-048	Comm Scope 735	48"	CPMC-68-33	CPMC-68-33
415-0050-060	Comm Scope 735	60"	CPMC-68-33	CPMC-68-33
415-0051-012	Belden 735A	12"	CPMC-68-33	CPMC-68-33
415-0051-024	Belden 735A	24"	CPMC-68-33	CPMC-68-33
415-0051-036	Belden 735A	36"	CPMC-68-33	CPMC-68-33
415-0051-048	Belden 735A	48"	CPMC-68-33	CPMC-68-33
415-0051-060	Belden 735A	60"	CPMC-68-33	CPMC-68-33
415-0053-012	Belden 1694A	12"	CPMC-68-45	CPMC-68-45
415-0053-024	Belden 1694A	24"	CPMC-68-45	CPMC-68-45
415-0053-036	Belden 1694A	36"	CPMC-68-45	CPMC-68-45
415-0053-048	Belden 1694A	48"	CPMC-68-45	CPMC-68-45
415-0053-060	Belden 1694A	60"	CPMC-68-45	CPMC-68-45

SMA Straight Plug to BNC Straight Plug



Part No.	Cable Type	Cable Length	Connector A	Connector B
415-0028-006	RG -316	6"	142-0403-011	CPM -88-19
415-0028-012	RG -316	12"	142-0403-011	CPM -88-19
415-0028-018	RG -316	18"	142-0403-011	CPM -88-19
415-0028-024	RG -316	24"	142-0403-011	CPM -88-19
415-0028-036	RG -316	36"	142-0403-011	CPM -88-19
415-0028-048	RG -316	48"	142-0403-011	CPM -88-19
415-0037-012	RG -58	12"	142-0407-011	CPMC-88-1
415-0037-024	RG -58	24"	142-0407-011	CPMC-88-1

Part No.	Cable Type	Cable Length	Connector A	Connector B
415-0037-036	RG-58	36"	142-0407-011	CPMC-88-1
415-0037-048	RG -58	48"	142-0407-011	CPMC-88-1
415-0037-060	RG -58	60"	142-0407-011	CPMC-88-1
415-0042-012	RG -142	12"	142-0408-011	CPMC-88-13
415-0042-024	RG -142	24"	142-0408-011	CPMC-88-13
415-0042-036	RG -142	36"	142-0408-011	CPMC-88-13
415-0042-048	RG -142	48"	142-0408-011	CPMC-88-13
415-0042-060	RG -142	60"	142-0408-011	CPMC-88-13

SMA Straight Plug to N Straight Plug



Part No.	Cable Type	Cable Length	Connector A	Connector B
415-0059-012	RG -58	12"	142-0407-011	CPN -1
415-0059-024	RG -58	24"	142-0407-011	CPN -1
415-0059-036	RG -58	36"	142-0407-011	CPN -1
415-0059-048	RG -58	48"	142-0407-011	CPN -1
415-0059-060	RG -58	60"	142-0407-011	CPN -1

Part No.	Cable Type	Cable Length	Connector A	Connector B
415-0061-012	RG -142	12"	142-0408-011	CPN -142T
415-0061-024	RG -142	24"	142-0408-011	CPN -142T
415-0061-036	RG -142	36"	142-0408-011	CPN -142T
415-0061-048	RG -142	48"	142-0408-011	CPN -142T
415-0061-060	RG -142	60"	142-0408-011	CPN -142T

For more information, please contact customer service at (507) 833-8822 or (800) 247-8256 • cinch.com

Illustrations are shown in inches (millimeters).



kwiQMate™ Straight to Straight

Part No.	Cable Type	Cable Length	Connector A	Connector B	Part No.	Cable Type	Cable Length	Connector A	Connector B
415-0162-006	RG-316DS	6"	146-0404-007	146-0404-007	415-0163-006	RG-316	6"	146-0403-007	146-0403-007
415-0162-012	RG-316DS	12"	146-0404-007	146-0404-007	415-0163-012	RG-316	12"	146-0403-007	146-0403-007
415-0162-024	RG-316DS	24"	146-0404-007	146-0404-007	415-0163-024	RG-316	24"	146-0403-007	146-0403-007
415-0162-036	RG-316DS	36"	146-0404-007	146-0404-007	415-0163-036	RG-316	36"	146-0403-007	146-0403-007
415-0162-048	RG-316DS	48"	146-0404-007	146-0404-007	415-0163-048	RG-316	48"	146-0403-007	146-0403-007



kwiQMate™ Straight to Right Angle

Part No.	Cable Type	Cable Length	Connector A	Connector B	Part No.	Cable Type	Cable Length	Connector A	Connector B
415-0171-006	RG-316DS	6"	146-0404-007	146-0404-107	415-0172-006	RG-316	6"	146-0403-007	146-0403-107
415-0171-012	RG-316DS	12"	146-0404-007	146-0404-107	415-0172-012	RG-316	12"	146-0403-007	146-0403-107
415-0171-024	RG-316DS	24"	146-0404-007	146-0404-107	415-0172-024	RG-316	24"	146-0403-007	146-0403-107
415-0171-036	RG-316DS	36"	146-0404-007	146-0404-107	415-0172-036	RG-316	36"	146-0403-007	146-0403-107
415-0171-048	RG-316DS	48"	146-0404-007	146-0404-107	415-0172-048	RG-316	48"	146-0403-007	146-0403-107



kwiQMate™ Right Angle to Right Angle

Part No.	Cable Type	Cable Length	Connector A	Connector B	Part No.	Cable Type	Cable Length	Connector A	Connector B
415-0174-006	RG-316DS	6"	146-0404-107	146-0404-107	415-0175-006	RG-316	6"	146-0403-107	146-0403-107
415-0174-012	RG-316DS	12"	146-0404-107	146-0404-107	415-0175-012	RG-316	12"	146-0403-107	146-0403-107
415-0174-024	RG-316DS	24"	146-0404-107	146-0404-107	415-0175-024	RG-316	24"	146-0403-107	146-0403-107
415-0174-036	RG-316DS	36"	146-0404-107	146-0404-107	415-0175-036	RG-316	36"	146-0403-107	146-0403-107
415-0174-048	RG-316DS	48"	146-0404-107	146-0404-107	415-0175-048	RG-316	48"	146-0403-107	146-0403-107



kwiQMate™ Straight to SMA Straight

Part No.	Cable Type	Cable Length	Connector A	Connector B	Part No.	Cable Type	Cable Length	Connector A	Connector B
415-0165-006	RG-316DS	6"	146-0404-007	142-0404-016	415-0166-006	RG-316	6"	146-0403-007	142-0403-016
415-0165-012	RG-316DS	12"	146-0404-007	142-0404-016	415-0166-012	RG-316	12"	146-0403-007	142-0403-016
415-0165-024	RG-316DS	24"	146-0404-007	142-0404-016	415-0166-024	RG-316	24"	146-0403-007	142-0403-016
415-0165-036	RG-316DS	36"	146-0404-007	142-0404-016	415-0166-036	RG-316	36"	146-0403-007	142-0403-016
415-0165-048	RG-316DS	48"	146-0404-007	142-0404-016	415-0166-048	RG-316	48"	146-0403-007	142-0403-016

Ultra Miniature Cable Assemblies

MMCX Cable Assemblies	
Specification	174
UMC to UMC.....	174
UMC to MMCX.....	175
UMC to SMA	176
Pigtail Cable	178
UMC Surface Mount Connector.....	179
Pigtail Cable Adapters	180
Other Information	
Assembly Tools	185
Capabilities	190
Cable Information.....	192
Assembly Instruction.....	193
Mounting Hole Layouts	194
Numerical Index	274
Competitor Cross Reference	280

While every precaution has been taken to ensure accuracy and completeness herein, Cinch Connectivity Solutions assumes no responsibility, and disclaims all liability for damages resulting from use of this information or for any errors or omissions. Specifications subject to change without notice.

For more information, please contact customer service at (507) 833-8822 or (800) 247-8256 • cinch.com

3	MMCX Connectors
13	MCX Connectors
39	SMK Connectors
45	SMA Connectors
103	SMB Connectors
131	SMC Connectors
137	SMP Connectors
145	Type N Connectors
153	Shielded Cable Terminations
157	Between-Series Adapters
161	Fixed Length Cable Assemblies
173	Ultra Miniature Connectors (UMC)
181	kwiQMAt[™] Connectors
185	Tools
193	Assembly Instructions
257	Electronic Hardware
274	Index

Specifications

- Impedance:** 50 Ω (Nominal)
- Temperature Range:** -40°C to +90°C
- Frequency Rating:** 0-6 GHz
- VSWR:** 1.30 max (0-6 GHz)
- Contact Resistance:** 20 m Ω max. (Center)
20 m Ω max. (Outer, for plug)
10 m Ω max. (Outer, for receptacle)
- Withstanding Voltage:** 200 V AC
- Insulation Resistance:** 500 M Ω min.
- Durability:** 30 cycles
- Holding Force (min.):** 0.15 N (Female contact)

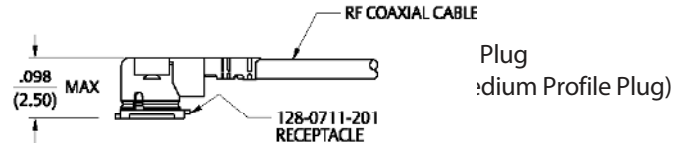
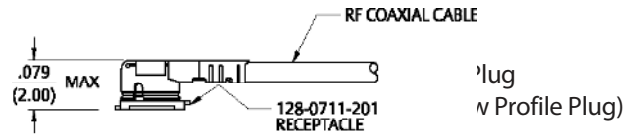

Low Profile UMC Right Angle Cable Plug to UMC Right Angle Cable Plug



Part No.	Teflon Coaxial Cable O.D.	Cable Length	Connector A	Plug Mated Height	Connector B
415-0084-050	0.81 mm	50 mm	UMC LP PLUG	2.0 mm	UMC LP PLUG
415-0084-100	0.81 mm	100 mm	UMC LP PLUG	2.0 mm	UMC LP PLUG
415-0084-150	0.81 mm	150 mm	UMC LP PLUG	2.0 mm	UMC LP PLUG
415-0084-200	0.81 mm	200 mm	UMC LP PLUG	2.0 mm	UMC LP PLUG
415-0084-250	0.81 mm	250 mm	UMC LP PLUG	2.0 mm	UMC LP PLUG
415-0084-300	0.81 mm	300 mm	UMC LP PLUG	2.0 mm	UMC LP PLUG
415-0084-500	0.81 mm	500 mm	UMC LP PLUG	2.0 mm	UMC LP PLUG

Medium Profile UMC Right Angle Cable Plug to UMC Right Angle Cable Plug



Part No.	Teflon Coaxial Cable O.D.	Cable Length	Connector A	Plug Mated Height	Connector B
415-0085-050	0.81 mm	50 mm	UMC MP PLUG	2.5 mm	UMC MP PLUG
415-0085-100	0.81 mm	100 mm	UMC MP PLUG	2.5 mm	UMC MP PLUG
415-0085-150	0.81 mm	150 mm	UMC MP PLUG	2.5 mm	UMC MP PLUG
415-0085-200	0.81 mm	200 mm	UMC MP PLUG	2.5 mm	UMC MP PLUG
415-0085-250	0.81 mm	250 mm	UMC MP PLUG	2.5 mm	UMC MP PLUG
415-0085-300	0.81 mm	300 mm	UMC MP PLUG	2.5 mm	UMC MP PLUG
415-0085-500	0.81 mm	500 mm	UMC MP PLUG	2.5 mm	UMC MP PLUG
415-0086-050	1.13 mm	50 mm	UMC MP PLUG	2.5 mm	UMC MP PLUG
415-0086-100	1.13 mm	100 mm	UMC MP PLUG	2.5 mm	UMC MP PLUG
415-0086-150	1.13 mm	150 mm	UMC MP PLUG	2.5 mm	UMC MP PLUG
415-0086-200	1.13 mm	200 mm	UMC MP PLUG	2.5 mm	UMC MP PLUG
415-0086-250	1.13 mm	250 mm	UMC MP PLUG	2.5 mm	UMC MP PLUG
415-0086-300	1.13 mm	300 mm	UMC MP PLUG	2.5 mm	UMC MP PLUG
415-0086-500	1.13 mm	500 mm	UMC MP PLUG	2.5 mm	UMC MP PLUG
415-0087-050	1.32 mm	50 mm	UMC MP PLUG	2.5 mm	UMC MP PLUG
415-0087-100	1.32 mm	100 mm	UMC MP PLUG	2.5 mm	UMC MP PLUG
415-0087-150	1.32 mm	150 mm	UMC MP PLUG	2.5 mm	UMC MP PLUG
415-0087-200	1.32 mm	200 mm	UMC MP PLUG	2.5 mm	UMC MP PLUG
415-0087-250	1.32 mm	250 mm	UMC MP PLUG	2.5 mm	UMC MP PLUG
415-0087-300	1.32 mm	300 mm	UMC MP PLUG	2.5 mm	UMC MP PLUG
415-0087-500	1.32 mm	500 mm	UMC MP PLUG	2.5 mm	UMC MP PLUG
415-0088-050	1.37 mm	50 mm	UMC MP PLUG	2.5 mm	UMC MP PLUG
415-0088-100	1.37 mm	100 mm	UMC MP PLUG	2.5 mm	UMC MP PLUG
415-0088-150	1.37 mm	150 mm	UMC MP PLUG	2.5 mm	UMC MP PLUG
415-0088-200	1.37 mm	200 mm	UMC MP PLUG	2.5 mm	UMC MP PLUG
415-0088-250	1.37 mm	250 mm	UMC MP PLUG	2.5 mm	UMC MP PLUG
415-0088-300	1.37 mm	300 mm	UMC MP PLUG	2.5 mm	UMC MP PLUG
415-0088-500	1.37 mm	500 mm	UMC MP PLUG	2.5 mm	UMC MP PLUG

UMC Right Angle Cable Plug to MMCX Right Angle Plug



Low Profile



Part No.	Teflon Coaxial Cable O.D.	Cable Length	Connector A	Plug Mated Height	Connector B
415-0101-150	0.81 mm	150 mm	UMC LP PLUG	2.0 mm	MMCX RA PLUG
415-0101-250	0.81 mm	250 mm	UMC LP PLUG	2.0 mm	MMCX RA PLUG

Medium Profile



Part No.	Teflon Coaxial Cable O.D.	Cable Length	Connector A	Plug Mated Height	Connector B
415-0102-150	0.81 mm	150 mm	UMC LP PLUG	2.5 mm	MMCX RA PLUG
415-0102-250	0.81 mm	250 mm	UMC LP PLUG	2.5 mm	MMCX RA PLUG

For more information, please contact customer service at (507) 833-8822 or (800) 247-8256 • cinch.com

Illustrations are shown in inches (millimeters).

SMA Cable Assembly

UMC Right Angle Cable Plug to SMA Straight Plug



Low Profile



Part No.	Teflon Coaxial Cable O.D.	Cable Length	Connector A	Plug Mated Height	Connector B
415-0089-150	0.81 mm	150 mm	UMC LP PLUG	2.0 mm	SMA STR. PLUG
415-0089-250	0.81 mm	250 mm	UMC LP PLUG	2.0 mm	SMA STR. PLUG

Medium Profile



Part No.	Teflon Coaxial Cable O.D.	Cable Length	Connector A	Plug Mated Height	Connector B
415-0090-150	0.81 mm	150 mm	UMC MP PLUG	2.5 mm	SMA STR. PLUG
415-0090-250	0.81 mm	250 mm	UMC MP PLUG	2.5 mm	SMA STR. PLUG
415-0091-150	1.37 mm	150 mm	UMC MP PLUG	2.5 mm	SMA STR. PLUG
415-0091-250	1.37 mm	250 mm	UMC MP PLUG	2.5 mm	SMA STR. PLUG

UMC Right Angle Cable Plug to SMA Bulkhead Straight Jack



Low Profile



Part No.	Teflon Coaxial Cable O.D.	Cable Length	Connector A	Plug Mated Height	Connector B
415-0095-150	0.81 mm	150 mm	UMC LP PLUG	2.0 mm	SMA STR BKHD. JACK
415-0095-250	0.81 mm	250 mm	UMC LP PLUG	2.0 mm	SMA STR BKHD. JACK

Medium Profile



Part No.	Teflon Coaxial Cable O.D.	Cable Length	Connector A	Plug Mated Height	Connector B
415-0096-150	0.81 mm	150 mm	UMC MP PLUG	2.5 mm	SMA STR BKHD. JACK
415-0096-250	0.81 mm	250 mm	UMC MP PLUG	2.5 mm	SMA STR BKHD. JACK
415-0097-150	1.37 mm	150 mm	UMC MP PLUG	2.5 mm	SMA STR BKHD. JACK
415-0097-250	1.37 mm	250 mm	UMC MP PLUG	2.5 mm	SMA STR BKHD. JACK

UMC Right Angle Cable Plug to SMA Straight Reverse Polarity Plug



Low Profile

Part No.	Teflon Coaxial Cable O.D.	Cable Length	Connector A	Plug Mated Height	Connector B
415-0092-150	0.81 mm	150 mm	UMC LP PLUG	2.0 mm	SMA STR. RP PLUG
415-0092-250	0.81 mm	250 mm	UMC LP PLUG	2.0 mm	SMA STR. RP PLUG

Medium Profile

Part No.	Teflon Coaxial Cable O.D.	Cable Length	Connector A	Plug Mated Height	Connector B
415-0093-150	0.81 mm	150 mm	UMC MP PLUG	2.5 mm	SMA STR. RP PLUG
415-0093-250	0.81 mm	250 mm	UMC MP PLUG	2.5 mm	SMA STR. RP PLUG
415-0094-150	1.37 mm	150 mm	UMC MP PLUG	2.5 mm	SMA STR. RP PLUG
415-0094-250	1.37 mm	250 mm	UMC MP PLUG	2.5 mm	SMA STR. RP PLUG

UMC Right Angle Cable Plug to SMA Straight Bulkhead Rev. Polarity Jack



Low Profile

Part No.	Teflon Coaxial Cable O.D.	Cable Length	Connector A	Plug Mated Height	Connector B
415-0098-150	0.81 mm	150 mm	UMC LP PLUG	2.0 mm	SMA STR BKHD. RP JACK
415-0098-250	0.81 mm	250 mm	UMC LP PLUG	2.0 mm	SMA STR BKHD. RP JACK

Medium Profile

Part No.	Teflon Coaxial Cable O.D.	Cable Length	Connector A	Plug Mated Height	Connector B
415-0099-150	0.81 mm	150 mm	UMC MP PLUG	2.5 mm	SMA STR BKHD. RP JACK
415-0099-250	0.81 mm	250 mm	UMC MP PLUG	2.5 mm	SMA STR BKHD. RP JACK
415-0100-150	1.37 mm	150 mm	UMC MP PLUG	2.5 mm	SMA STR BKHD. RP JACK
415-0100-250	1.37 mm	250 mm	UMC MP PLUG	2.5 mm	SMA STR BKHD. RP JACK

For more information, please contact customer service at (507) 833-8822 or (800) 247-8256 • cinch.com

Illustrations are shown in inches (millimeters).

Pigtail Cable Assembly

0.81 mm Coaxial Cable

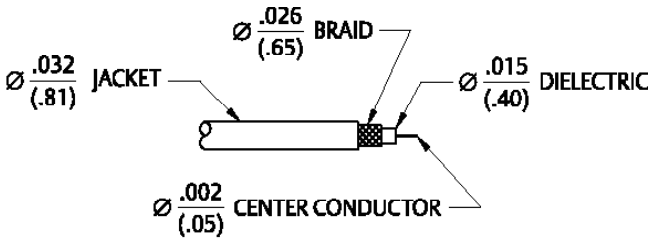

1.32 mm Coaxial Cable

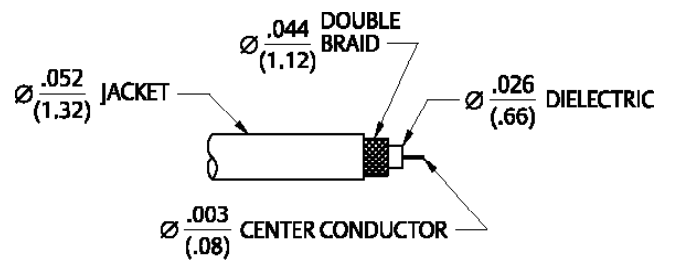

1.13 mm Coaxial Cable

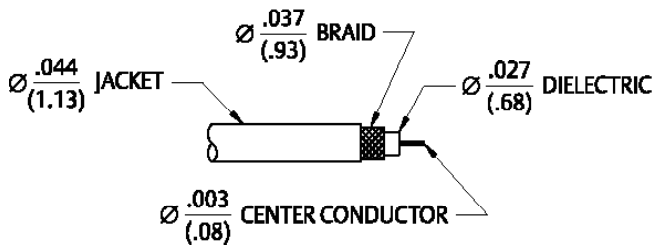

1.37 mm Coaxial Cable

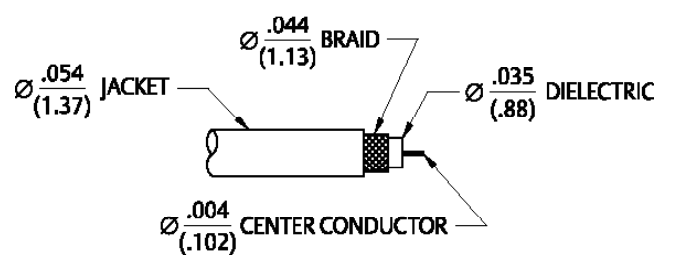

UMC Right Angle Cable Plug to Bare End

Low Profile



Part No.	Teflon Coaxial Cable O.D.	Cable Length	Connector A	Plug Mated Height	Connector B
415-0104-150	0.81 mm	150 mm	UMC LP PLUG	2.0 mm	BARE END
415-0104-250	0.81 mm	250 mm	UMC LP PLUG	2.0 mm	BARE END

Medium Profile



Part No.	Teflon Coaxial Cable O.D.	Cable Length	Connector A	Plug Mated Height	Connector B
415-0105-150	0.81 mm	150 mm	UMC MP PLUG	2.5 mm	BARE END
415-0105-250	0.81 mm	250 mm	UMC MP PLUG	2.5 mm	BARE END
415-0106-150	1.13 mm	150 mm	UMC MP PLUG	2.5 mm	BARE END
415-0106-250	1.13 mm	250 mm	UMC MP PLUG	2.5 mm	BARE END
415-0107-150	1.32 mm	150 mm	UMC MP PLUG	2.5 mm	BARE END
415-0107-250	1.32 mm	250 mm	UMC MP PLUG	2.5 mm	BARE END
415-0108-150	1.37 mm	150 mm	UMC MP PLUG	2.5 mm	BARE END
415-0108-250	1.37 mm	250 mm	UMC MP PLUG	2.5 mm	BARE END

Straight Jack Receptable – Surface Mount



Part No.	Packaging
128-0711-201	Stock
128-0711-202	Tape & Reel 2,500 pcs/reel

Tape and Reel Specifications

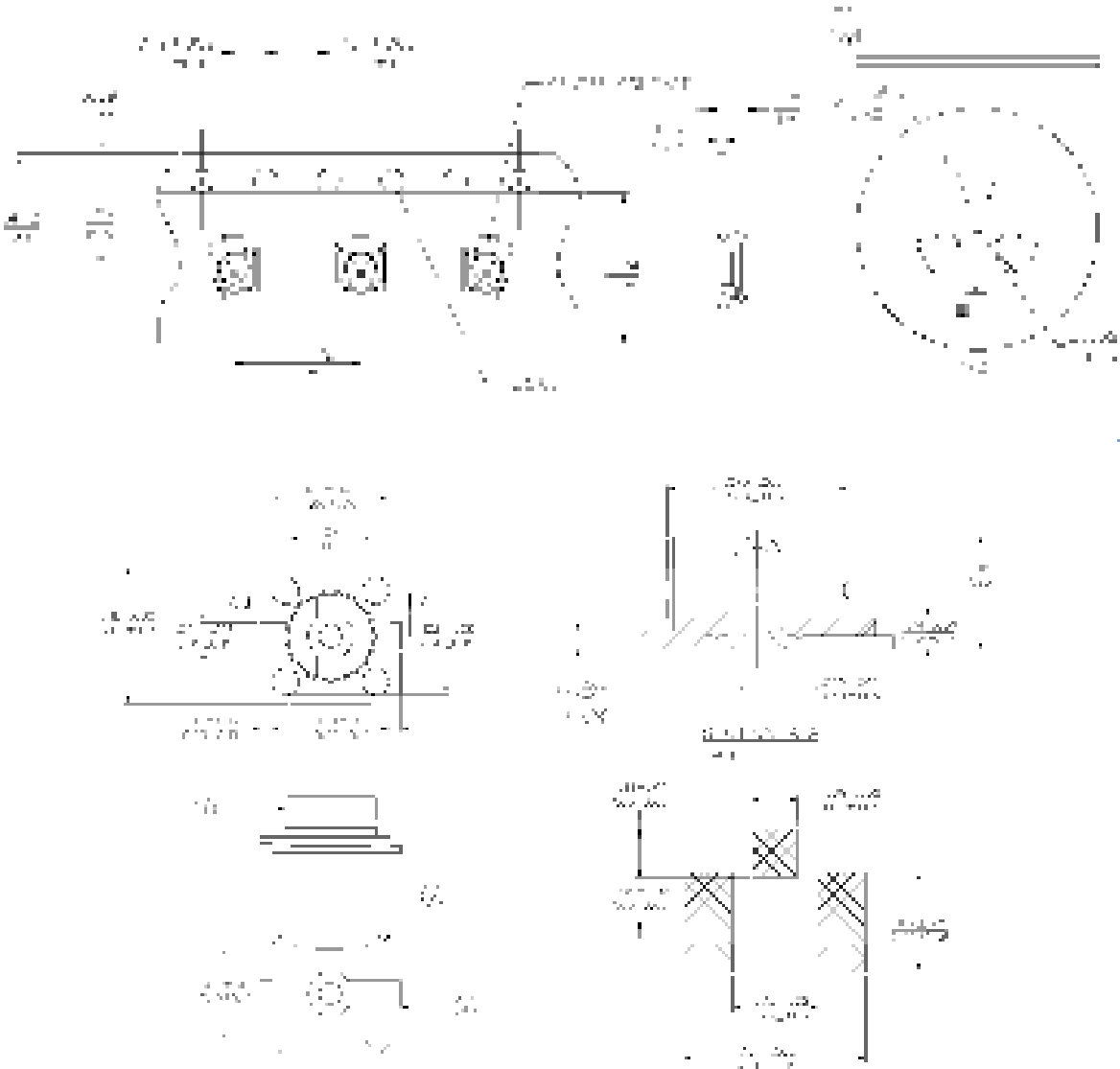

For more information, please contact customer service at (507) 833-8822 or (800) 247-8256 • cinch.com
Illustrations are shown in inches (millimeters).

Pigtail Assembly Adapters

SMA Conversion Adapter for Mating UMC Plugs (SMA Plug to UMC Jack)



Part No.
134-1019-361

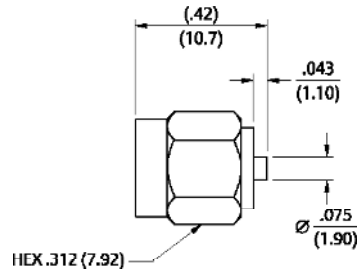

SMA Conversion Adapter for Surface Mt. Jack Receptacle 128-0711-201 (SMA Jack to UMC Plug)



Part No.
134-1019-371

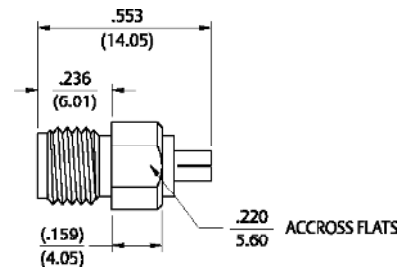

Inspection Tool for Cable Assembly



Part No.
134-1019-381

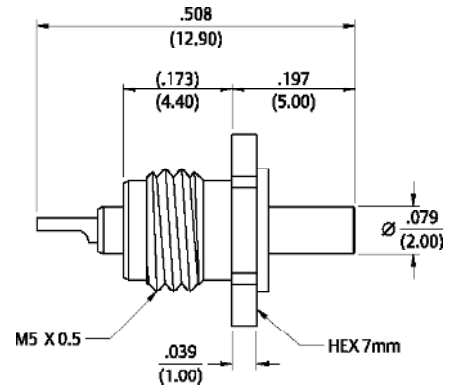

UMC Separation Key



Part No.
128-0000-901

kwiQMate™ Connectors

Specification	182
Semi-Rigid & Flexible Cable	184
PC Mount.....	184
Other Information	
Assembly Tools	185
Capabilities.....	190
Cable Information.....	192
Assembly Instruction.....	193
Mounting Hole Layouts.....	194
Numerical Index	274
Competitor Cross Reference	280

3	MMCX Connectors
13	MCX Connectors
39	SMK Connectors
45	SMA Connectors
103	SMB Connectors
131	SMC Connectors
137	SMP Connectors
145	Type N Connectors
153	Shielded Cable Terminations
157	Between-Series Adapters
161	Fixed Length Cable Assemblies
173	Ultra Miniature Connectors (UMC)
181	kwiQMate™ Connectors
185	Tools
193	Assembly Instructions
257	Electronic Hardware
274	Index

While every precaution has been taken to ensure accuracy and completeness herein, Cinch Connectivity Solutions assumes no responsibility, and disclaims all liability for damages resulting from use of this information or for any errors or omissions. Specifications subject to change without notice.

Specifications

Electrical Specifications

Impedance: 50 Ohms
Frequency Range: 12.4 GHz

VSWR: (f = GHz)	<u>Straight Cable Connectors</u>	<u>Right Angle Cable Connectors</u>
RG-316, RG-316 DS	1.15+.02f	1.15+.03f
Uncabled receptacles	N/A	

Working Voltage: (VRMS max)	<u>Sea Level</u>	<u>70K Feet</u>
RG-316, RG-316 DS	250	65
Uncabled receptacles	335	85

Dielectric Withstanding Voltage: VRMS min (at sea level)

Connectors for RG-316, RG-316 DS750
Uncabled receptacles1000

Insulation Resistance: 5000 Megohms min

Contact Resistance: (milliohms max)	<u>Initial</u>	<u>After Environmental</u>
Center contact (straight cabled connectors and Uncabled receptacles)	3.0	4.0
Center contact (right angle cabled connectors)	4.0	6.0
Outer Contact (all connectors)	2.0	N/A
Braid to Body (Tri-Alloy plated bodies)	3.0	N/A
Braid to Body (gold plated bodies)	0.5	N/A

Corona Level: (Volts min at 70,000 feet)

Connectors for RG-316, RG-316 DS190
Uncabled receptacles250

Insertion Loss: (dB max)

Straight flexible cable connectors	0.06	$f\sqrt{\text{(GHz)}}$, tested at 6 GHz
Right angle flexible cable connectors	0.15	$f\sqrt{\text{(GHz)}}$, tested at 6 GHz
Uncabled receptacles		N/A

RF Leakage: (dB max, tested at 3 GHz)

Cable connectors	-80
Uncabled receptacles	N/A

RF High Potential Withstanding Voltage: (Vrms min, tested at 4 and 7 MHz)

Connectors for RG-316, RG-316 DS500
Uncabled receptacles670

Mechanical Specifications

Engagement Design:

- Durability:** 500 cycles min
- Engagement/Disengagement Force:** 8 lbs max (5 lbs typical)
- Coupling Retention Force:** 10 lbs min
- Contact Retention:** 6 lbs min axial force (captivated contacts)
4 oz-in min torque (uncabled receptacles)

Cable Retention: (min*)

	<u>Axial Force (lbs)</u>	<u>Torque (oz-in)</u>
Connectors for RG-316, RG-316 DS	20	N/A

* Or cable breaking strength, whichever is less

Material Specifications

Bodies:	Brass per QQ-B-626, Tri-Alloy (Cu/Sn/Zn) plated .0001" min
Contacts:	Male - Brass per ASTM B16, Gold plated* per MIL-G-45204 .00005" min Female - Beryllium Copper per ASTM B196, Gold plated* per MIL-G-45204 .00005" min
Insulators:	PTFE Fluorocarbon per ASTM D1710 and ASTM D1457
Gaskets:	Silicon Rubber per ZZ-R-765
Expansion Caps:	Brass per QQ-B-613, Tri-Alloy (Cu/Sn/Zn) plated .0001" min
Crimp Sleeves:	Copper per ASTM A75, Tri-Alloy (Cu/Sn/Zn) plated .0001" min
Coupling Retention Spring (Plugs):	Beryllium Copper per ASTM B196, Tri-Alloy (Cu/Sn/Zn) plated .0001" min
Mounting Hardware:	Brass per QQ-B-626, or QQ-B 613, Tri-Alloy (Cu/Sn/Zn) plated .0001" min

* Gold plated parts include a .00005" min nickel barrier layer

Environmental Specifications

(Meets or Exceeds the Applicable Paragraph of MIL-PRF-39012)

Temperature Range:	-65°C to +165°C
Thermal Shock:	MIL-STD-202, Method 107, Condition B (except +85°C high temperature)
Corrosion:	MIL-STD-202, Method 101, Condition B
Shock:	MIL-STD-202, Method 213, Condition I
Vibration:	MIL-STD-202, Method 204, Condition D
Moisture Resistance:	MIL-STD-202, Method 106

MATING ENGAGEMENT FOR kwiQMAte™

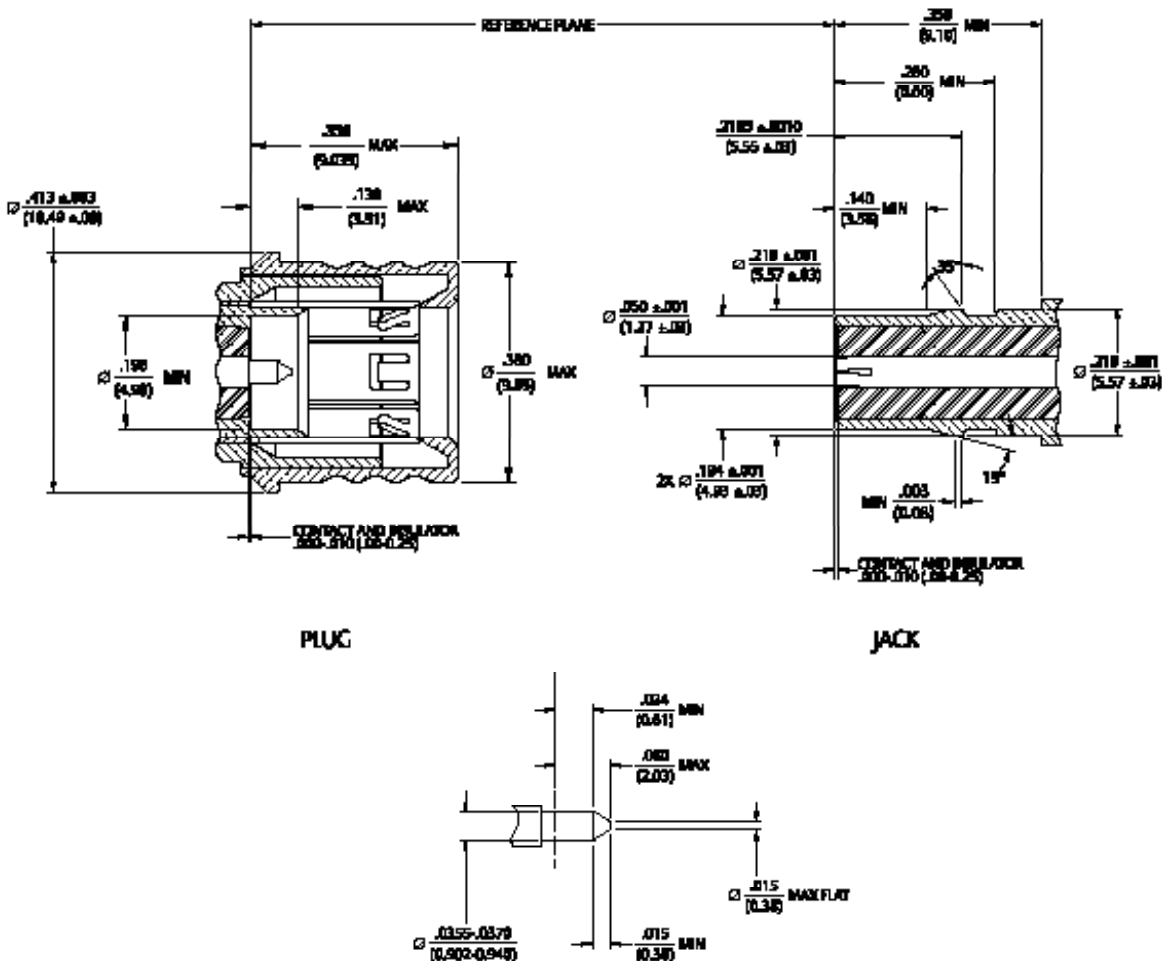

For more information, please contact customer service at (507) 833-8822 or (800) 247-8256 • cinch.com

Illustrations are shown in inches (millimeters).

Straight Crimp Type Plug (3-piece) – Captivated Contact



Cable Type	Tri-Alloy Plated
RG-316	146-0403-007
RG-316 DS	146-0404-007

Assembly instructions page 256.

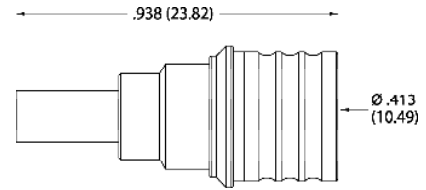

Right Angle Crimp Type Plug (1-piece body) – Captivated Contact



Cable Type	Tri-Alloy Plated
RG-316	146-0403-107
RG-316 DS	146-0404-107

Assembly instructions page 255.

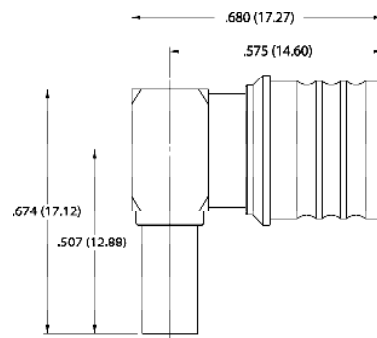

Straight Jack Receptacle



Gold Plated
146-0701-201

Mounting hole layout figure 2 page 194.

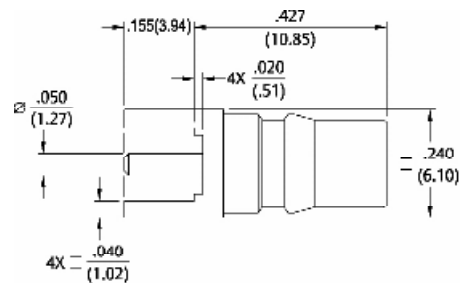

Right Angle Jack Receptacle



Gold Plated
146-0701-301

Mounting hole layout figure 2 page 194.

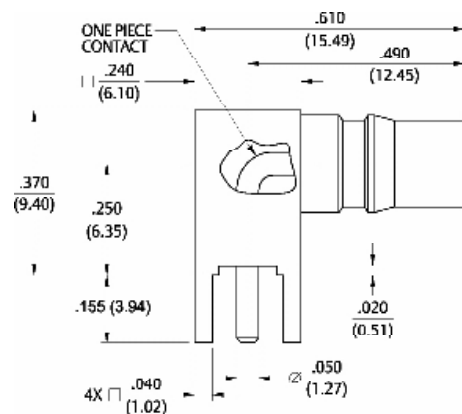

Tools

Other Information	
Assembly Tools	185
Capabilities	190
Cable Information	192
Assembly Instruction	193
Mounting Hole Layouts	194
Numerical Index	274
Competitor Cross Reference	280

3	MMCX Connectors
13	MCX Connectors
39	SMK Connectors
45	SMA Connectors
103	SMB Connectors
131	SMC Connectors
137	SMP Connectors
145	Type N Connectors
153	Shielded Cable Terminations
157	Between-Series Adapters
161	Fixed Length Cable Assemblies
173	Ultra Miniature Connectors (UMC)
181	kwiQMate™ Connectors
185	Tools
193	Assembly Instructions
257	Electronic Hardware
274	Index

While every precaution has been taken to ensure accuracy and completeness herein, Cinch Connectivity Solutions assumes no responsibility, and disclaims all liability for damages resulting from use of this information or for any errors or omissions. Specifications subject to change without notice.

Coaxial Connector Assembly Tools

Hand Crimp Tool

Precision Astro Tool hand crimping tool makes cable assembly fast and easy. Crimping tool features interchangeable steel dies. Ratchet action of tool controls crimping operation for precise uniform ferrule crimps.



Connector Type	Cable Type	Preferred Die Set	Crimp Dimensions
MCX SMA SMB SMC	RG-178/U RG-196/U	141-0000-901	Hex = .105 (2.67) Width = .325 (8.26)
MCX SMA SMB SMC 75 Ohm SMB	RG-161/U, RG-174/U RG-179/U, RG-187/U RG-188/U, RG-316/U LMR-100	141-0000-902	Hex = .128 (3.25) Width = .400 (10.16)
	RG-188/U, RG316/U RG-179/U, RG-187/U BELDEN 735A	141-0000-905	Hex = .151 (3.83) Width = .400 (10.16)
MCX SMA SMB	RG-58/U RG-141/U RG-303/U RG-55/U RG-142/U RG-223/U RG-400/U LMR-195 LMR-200	141-0000-903	Hex = .213 (5.41) Width = .375 (9.52)
SMA 75 Ohm SMB	LMR-240, RG-59	141-0000-925	Hex = .255 (6.48) Width = .400 (10.16)
N Type	RG-316/U, 316 DS	141-0000-927	Hex = .160 (4.06) Width = .400 (10.16)

* Economy Hand Crimp Tool also available with four hex sizes in one tool page 187.

Ordering Information for Crimp Tool

Part No.	Description	ASTRO Tool Part No.
144-0000-900	Frame Only	620175
141-0000-901	Single Hex Die	620932
141-0000-902	Single Hex Die	620419
141-0000-903	Single Hex Die	620676
141-0000-905	Single Hex Die	630055
141-0000-925	Single Hex Die	620938
141-0000-927	Single Hex Die	620297

Ordering Information for Crimp Tool

Connector Type	Preferred Die Ste	Crimp Style
SMB Cross Hole Style Body 50 Ohm Only	141-0000-911	Double Diamond
Mini 75 Ohm SMB, MCX 75 Ohm Cross Hole Style Body	141-0000-924	Double Diamond

Economy Hand Crimp Tool

Hand crimp tool and die set includes all hex sizes necessary for subminiature connector applications. Ratchet tool action insures a complete crimp every time.

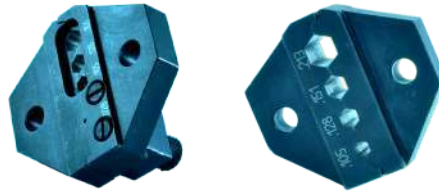

Part No.	Description	Hex	Width	Connector Type
140-0000-952	Hand Crimp Tool Frame Only			
140-0000-953	Die for .047" dia. flexible cable; RG-178, RG-316, RG-316 DS and Contact Crimp w/stop	.105 (2.67) .128 (3.25) .151 (3.83) Diamond Crimp for 038 (0.96) Dia. Contact	.250 (6.35) .250 (6.35) .250 (6.35) .035 (0.89)	MMCX*, MCX
140-0000-951	Die for RG-178, 316, 316 DS 58, 142, LMR-100, LMR-195, LMR-200A	.105 (2.67) .128 (3.25) .151 (3.83) .213 (5.41)	.390 (9.91) .390 (9.91) .390 (9.91) .390 (9.91)	MCX, SMB, SMC, SMA, 75 OHM SMB
140-0000-955	Die for RG-179, 179 DS, 735A, RG-59, LMR-240	.128 (3.25) .151 (3.83) .178 (4.52) .255 (6.48)	.390 (9.91) .390 (9.91) .390 (9.91) .390 (9.91)	75 Ohm MCX, SMA Mini-75 Ohm SMB

* Use 140-0000-951 for MMCX straight cabled bulkhead jack body crimp.

Economy Hand Crimp Tool

Hand crimp tool and die set includes all hex sizes necessary for subminiature connector applications. Ratchet tool action insures a complete crimp every time.



Part No.	Description	ASTRO Tool Part No.	Military Part No.
144-0000-910	Frame Only	615708	M22520/1-01
141-0000-907	Positioner	650027	N/A

Economy Hand Crimp Tool

Hand crimp tool and die set includes all hex sizes necessary for subminiature connector applications. Ratchet tool action insures a complete crimp every time.



Part No.	Description	ASTRO Tool Part No.
140-0000-970	Frame Only	612118-1
140-0000-971	Positioner	N/A

MMCX Assembly/Decoupling Tool

This tool will assemble the end cap to a standard right angle MMCX plug connector in the field. Simply insert connector and cap into tool cavity, then turn handle to swage the cap into place. The slotted end of the tool can be used to disengage a right angle MMCX plug from a mating receptacle.

Part No.
141-0000-910



For more information, please contact customer service at (507) 833-8822 or (800) 247-8256 • cinch.com

Illustrations are shown in inches (millimeters).

Coaxial Connector Assembly Tools

MCX Right Angle Plug Assembly Tool

This quick and easy to use tool will press the end cap onto standard right angle MCX plug connectors. Simply insert the connector and cap into the staking nest and a light squeeze of the handles will swage the cap into place. The jaw tips are shaped to grip a right angle MCX plug body for insertion or disengagement to a mating receptacle. The jaws are hardened steel and the handles are cushioned to minimize stress to the user. For use with all cable groups except RG-58.



Part No.
141-0000-908

SMA Knurl Mount Assembly Tool

The Knurl Mount SMA Spark Plug Connectors can be pressed into position using this thread-on fixture designed for low volume lab use.



Part No.
140-0000-954

SMB Plug Removal Tool

Reaches in to disengage SMB connectors in high density packaging applications.



Part No.
140-0000-956

SMK (2.92mm) Tools

Accurate assembly of the SMK cabled connectors is obtained with the tools listed below. Industry standard devices are used if possible for customer convenience and tool compatibility.

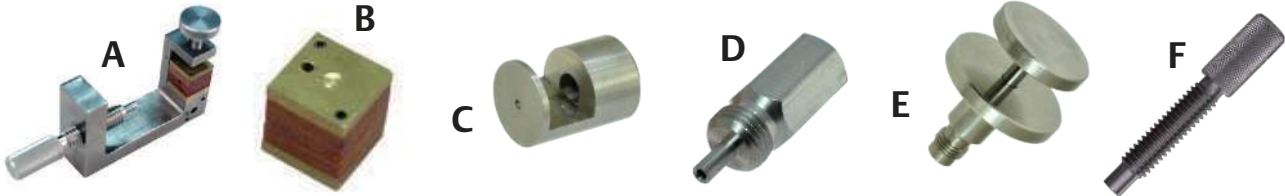

Item	Part No.	Description
A	140-0000-962	Semi-Rigid Cable Vise (does not include inserts (B) or Vise Stop (F))
B	140-0000-964 140-0000-965	Cable Clamp Inserts, .086 Semi-Rigid Cable Clamp Inserts, .141 Semi-Rigid
C	140-0000-960 140-0000-961	Contact Soldering Tool, .086 Plug Contact Soldering Tool, .141 Plug
D	140-0000-958 140-0000-959	Body Soldering Tool, .086 Plug Body Soldering Tool, .141 Plug
E	140-0000-957	Bead Assembly Tool, Semi-Rigid Plugs, All Cables
F	140-0000-968	Vise Stop, (2.92mm)

We Have What You Are Looking For ... and If We Don't, We'll Design and Manufacture It!!!

Cinch Connectivity Solutions prides itself in meeting our customers' needs by providing them with customized solutions. We have configured our technical staff and equipped our model shop and QA lab to meet the quick-turn demands of new product development. Prototypes, samples, and short-run quantities are delivered expediently and to print. Your new product development life cycle will be greatly enhanced with us as a partner on your design team.

We have an extensive log of special variations of MMCX, MCX, 75 Ohm MCX, SMK, SMA, SMP, SMB, Mini-75 Ohm SMB, SMC, BNC, TNC and N connectors. Special cable sizes, cable assemblies, PC board terminations, adapters, antenna connectors, multi-packs, calibration terminations and hardware products give us a large pool of design experience to assist you with custom development. See page 259 for more information on our custom hardware products.

Our sales representatives will review your product application and initiate the quotation process, and our sales and engineering staff will assist you in defining the performance and cost parameters required by your end product. Providing details such as dimensional limitations, frequency, and VSWR performance to our field sales representative will speed the process.

After you have chosen us as your supplier, we can provide samples and a short run quantity prior to production of your custom product. We look forward to providing your special electronic components in the future.

We do it all...

Virtually any RF coaxial connector or RF cable assembly from the engineering, prototyping and tooling stages, to complete production and testing.

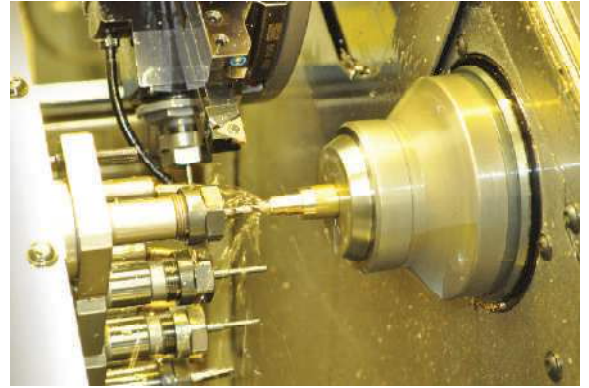

N Jack 75 Ohm to MCX Plug
75 Ohm Assembly, Adapter



Ganged MCX Right-Angle
Board Mount



SMB Vertical
PC Plug

With over 75 years of experience, Cinch Connectivity Solutions is your interconnect solution for cable assembly design, high quality production and on-time delivery. Our Johnson line of precision cable assemblies includes standard RF coaxial cable assemblies such as flexible, conformable and semi-rigid types for 50 or 75 ohm systems from 0 to 40 GHz. We can work with almost any connector, including our complete line of Johnson connectors including SMK, SMP, SMA, SMB, SMC, BNC, TNC, N, F, UHF, Mini-UHF, MCX and MMCX connectors. Cable assemblies manufactured with our RF connectors assure you controlled impedance throughout the cable length. Our skilled personnel adhere to rigorous quality assurance procedures, giving you the cables you need, on time, without hassles.



Backed by test data shipped with the product! Our assemblies are delivered completely tested to customer specifications and carry our complete customer satisfaction guarantee. By having us make your cable assemblies, you save the cost of training personnel; discarding damaged parts; cable testing; and replacing faulty inventory. You save on overhead, manufacturing and equipment costs and you receive proven cost effective cable assemblies on time and to your specifications. We are an industry leader in the RF coaxial connector and electronic hardware market...you can rely on Cinch Connectivity Solutions for all your assembly needs.



We're responsive, reliable and ready to work with you.



2x3 Position SMA Straight Plug to MCX Straight Plug



For more information, please contact customer service at (507) 833-8822 or (800) 247-8256 • cinch.com

Illustrations are shown in inches (millimeters).

Cable Information



Semi-Rigid Cable Dimensions

Cable	Center Conductor O.D.	O.D. Dielectric	O.D. Shield	Impedance
RG-405/U	.0201 (0.51)	.0658 (1.67)	.086 (2.18)	50
RG-402/U	.0359 (0.91)	.1175 (2.98)	.141 (3.58)	50

RF Flexible Cable Dimension

Cable	Center Conductor	O.D. Dielectric	O.D. Shield	O.D. Jacket	Impedance
.047 dia.	.007 (0.19)	.020 (0.52)	.035 (0.90)	.047 (1.20)	50
RG-178B/U	.012 (.030)	.034 (0.86)	.054 (1.37)	.071 (1.80)	50
RG-196A/U	.012 (.030)	.034 (0.86)	.054 (1.37)	.071 (1.80)	50
RG-174/U	.019 (0.48)	.060 (1.52)	.080 (2.03)	.110 (2.79)	50
RG-179B/U	.012 (.030)	.063 (1.60)	.084 (2.13)	.110 (2.79)	75
RG-187A/U	.012 (.030)	.060 (1.52)	.084 (2.13)	.110 (2.79)	75
RG-188A/U	.020 (0.51)	.060 (1.52)	.081 (2.06)	.110 (2.79)	50
RG-316/U	.020 (0.51)	.060 (1.52)	.081 (2.06)	.110 (2.79)	50
RG-316 DS	.020 (0.51)	.060 (1.52)	(DS) .100 (2.54)	.120 (3.05)	50
RG-179 DS	.012 (.030)	.063 (1.60)	(DS) .103 (2.62)	.120 (3.05)	75
RG-187 DS	.012 (.030)	.060 (1.52)	(DS) .100 (2.54)	.120 (3.05)	75
RG-188 DS	.020 (0.51)	.060 (1.52)	(DS) .100 (2.54)	.120 (3.05)	50
RG-141A/U	.039 (0.99)	.116 (2.95)	.146 (3.71)	.190 (4.83)	50
RG-303/U	.039 (0.96)	.116 (2.95)	.146 (3.71)	.190 (4.83)	50
RG-400/U	.038 (0.96)	.116 (2.95)	(DS) .171 (4.34)	.195 (4.85)	50
RG-142B/U	.039 (0.99)	.116 (2.95)	(DS) .171 (4.34)	.195 (4.95)	50
RG-58C/U	.038 (0.96)	.116 (2.95)	.150 (3.81)	.195 (4.95)	50
RG-55B/U	.032 (0.81)	.116 (2.95)	(DS) .176 (4.47)	.206 (5.23)	53.5
RG-223/U	.032 (0.81)	.116 (2.95)	(DS) .176 (4.47)	.206 (5.23)	53.5
LMR-100	.022 (.056)	.062 (1.57)	.085 (2.16)	.105 (2.67)	50
LMR-195	.037 (0.94)	.110 (2.79)	.139 (3.53)	.195 (4.95)	50
LMR-200	.044 (1.12)	.116 (2.95)	.144 (3.66)	.195 (4.95)	50
LMR-240	.056 (1.42)	.150 (3.81)	.178 (4.52)	.240 (6.10)	50
735A	.016 (0.41)	.077 (1.96)	.101 (2.57)	.128 (3.25)	75
RG-59	.0226 (0.57)	.146 (3.71)	.191 (4.85)	.242 (6.15)	75

Assembly Instructions

Other Information	
Assembly Tools	185
Capabilities	190
Cable Information	192
Assembly Instruction	193
Mounting Hole Layouts	194
Numerical Index	274
Competitor Cross Reference	280

3	MMCX Connectors
13	MCX Connectors
39	SMK Connectors
45	SMA Connectors
103	SMB Connectors
131	SMC Connectors
137	SMP Connectors
145	Type N Connectors
153	Shielded Cable Terminations
157	Between-Series Adapters
161	Fixed Length Cable Assemblies
173	Ultra Miniature Connectors (UMC)
181	kwiQMate™ Connectors
185	Tools
193	Assembly Instructions
257	Electronic Hardware
274	Index

While every precaution has been taken to ensure accuracy and completeness herein, Cinch Connectivity Solutions assumes no responsibility, and disclaims all liability for damages resulting from use of this information or for any errors or omissions. Specifications subject to change without notice.

Recommended Mounting Hole Dimensions

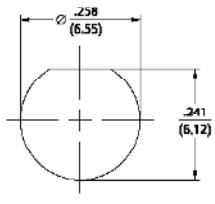

1

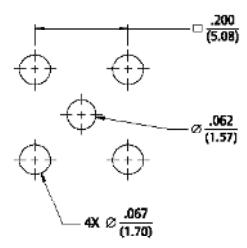

2

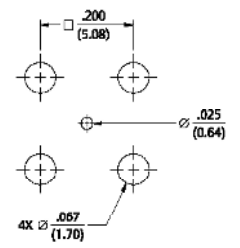

3

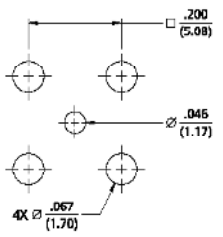

4

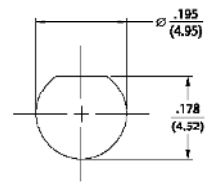

5

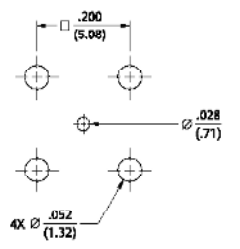

6

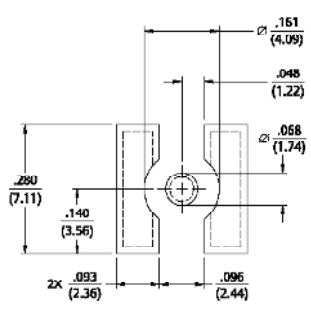

7

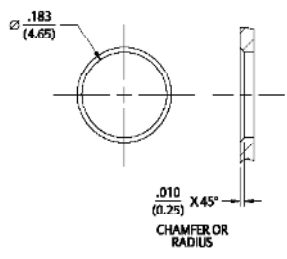

8

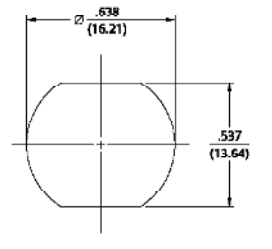

9

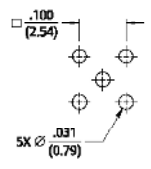

10

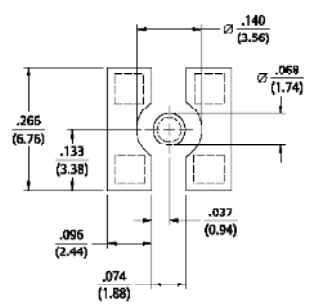

11

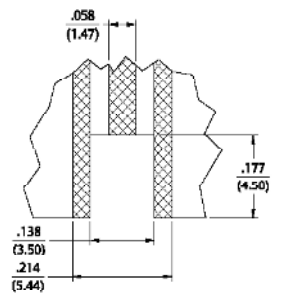

12

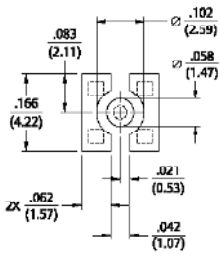

13

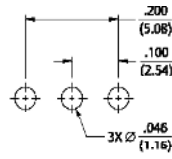

14

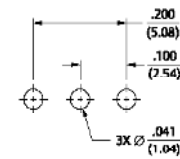

15

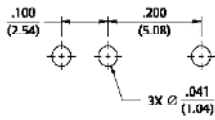

16

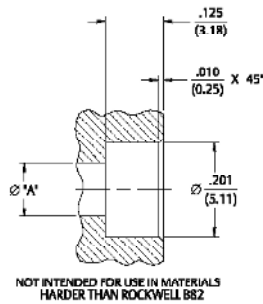

17

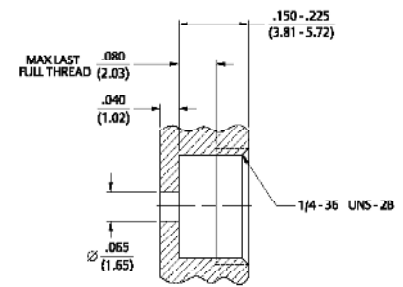

18

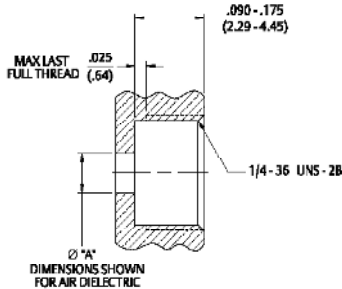

19

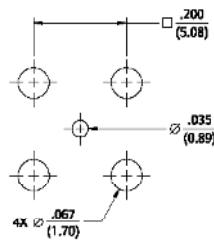

20

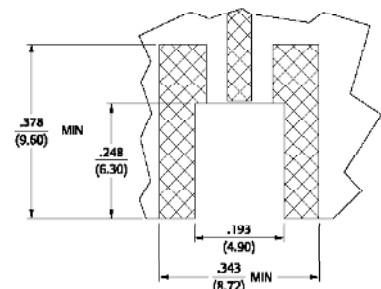

21

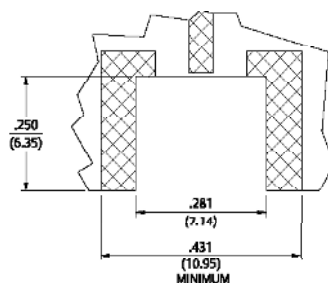

22

For more information, please contact customer service at (507) 833-8822 or (800) 247-8256 • cinch.com

Illustrations are shown in inches (millimeters).

Reference

131-1402-101	238	131-6404-006	237	133-3403-101	210	135-3436-001	202
131-1402-116	238	131-6404-101	238	133-3403-106	210	135-3436-101	200
131-1403-001	237	131-6404-106	238	133-3404-001	207	135-3693-101	198
131-1403-016	237	131-6433-001	237	133-3404-006	207	135-9402-001	205
131-1403-101	238	131-6433-006	237	133-3404-101	210	135-9402-111	199
131-1403-116	238	131-6433-101	238	133-3404-106	210	135-9403-001	204
131-1404-001	237	131-6433-106	238	133-3407-101	210	135-9403-101	199
131-1404-016	237	131-6593-401	233	133-3407-106	210	135-9404-001	204
131-1404-101	238	131-6593-406	233	133-3433-001	207	135-9436-001	205
131-1404-116	238	131-8303-401	237	133-3433-006	207	135-9436-101	200
131-1693-101	234	131-8303-406	237	133-3433-101	210	138-4303-407	248
131-1693-116	234	131-8304-401	237	133-3433-106	210	138-4304-407	248
131-3302-001	237	131-8304-406	237	133-3693-001	206	138-4307-407	251
131-3302-006	237	131-8403-001	237	133-3693-006	206	138-4308-407	251
131-3303-001	237	131-8403-006	237	133-3693-101	206	138-4316-407	251
131-3303-006	237	131-8403-011	237	133-3693-106	206	138-4318-407	251
131-3303-401	237	131-8403-016	237	133-5302-401	207	138-4349-407	251
131-3303-406	237	131-8403-101	238	133-5302-406	207	138-4403-007	242
131-3303-501	238	131-8403-106	238	133-5303-401	207	138-4403-107	244
131-3303-506	238	131-8403-111	238	133-5303-406	207	138-4404-007	242
131-3304-401	237	131-8403-116	238	133-5304-401	207	138-4404-107	244
131-3304-406	237	131-8404-001	237	133-5304-406	207	138-4407-007	243
131-3304-501	238	131-8404-006	237	133-5402-001	207	138-4407-107	244
131-3304-506	238	131-8404-011	237	133-5402-006	207	138-4408-007	243
131-3402-001	237	131-8404-016	237	133-5402-101	210	138-4408-107	244
131-3402-016	237	131-8404-101	238	133-5402-106	210	138-4416-007	243
131-3402-101	238	131-8404-106	238	133-5403-001	207	138-4416-107	245
131-3402-116	238	131-8404-111	238	133-5403-006	207	138-4418-007	243
131-3403-001	237	131-8404-116	238	133-5403-101	210	138-4418-107	245
131-3403-016	237	131-8409-001	237	133-5403-106	210	138-4449-007	243
131-3403-021	232	131-8409-006	237	133-5404-001	207	138-4593-401	250
131-3403-026	232	131-8409-101	238	133-5404-006	207	138-4594-401	250
131-3403-101	238	131-8409-106	238	133-5404-101	210	138-4596-401	250
131-3403-116	238	131-8433-001	232	133-5404-106	210	138-4693-001	246
131-3403-401	237	131-8433-006	232	133-8333-001	209	138-4693-011	247
131-3403-406	237	131-8434-001	232	133-8333-401	209	138-4694-001	246
131-3404-001	237	131-8434-006	232	133-8334-001	209	138-4694-011	247
131-3404-016	237	131-8445-001	237	133-8334-401	209	138-4696-001	246
131-3404-021	232	131-8445-006	237	133-8433-001	209	138-4696-011	247
131-3404-026	232	131-8445-011	232	133-8433-101	211	138-9408-007	240
131-3404-101	238	131-8445-016	232	133-8434-001	209	138-9449-007	240
131-3404-116	238	131-8445-101	238	133-8434-101	211	141-0303-412	219
131-3404-401	237	131-8445-106	238	133-8445-001	209	141-0304-412	219
131-3404-406	237	131-9403-001	235	133-8445-101	211	141-0307-412	219
131-3407-001	237	131-9403-021	232	133-9402-101	208	141-0308-412	219
131-3407-006	237	131-9403-101	236	133-9403-001	207	141-0403-012	219
131-3407-011	232	131-9403-116	236	133-9403-101	208	141-0403-102	224
131-3407-016	232	131-9404-001	235	133-9403-104	208	141-0404-012	219
131-3407-101	238	131-9404-021	232	133-9404-001	207	141-0404-112	224
131-3407-106	238	131-9404-101	236	133-9404-101	208	141-0407-012	219
131-3593-401	233	131-9404-116	236	134-0303-406	239	141-0407-102	224
131-3593-406	233	133-3302-001	207	134-0304-406	239	141-0408-012	219
131-3693-001	233	133-3302-006	207	134-0307-406	239	141-0408-102	224
131-3693-016	233	133-3302-401	207	134-0308-406	239	141-0593-001	214
131-3693-101	234	133-3302-406	207	135-3302-001	205	141-0593-401	214
131-3693-116	234	133-3303-001	207	135-3302-401	205	141-0593-421	222
131-3694-401	233	133-3303-006	207	135-3303-001	204	141-0594-001	214
131-3694-406	233	133-3303-401	207	135-3304-001	204	141-0594-401	214
131-6303-401	237	133-3303-406	207	135-3333-001	204	141-0594-421	222
131-6303-406	237	133-3304-001	207	135-3336-001	205	141-0693-002	214
131-6304-401	237	133-3304-006	207	135-3336-401	205	141-0693-062	222
131-6304-406	237	133-3304-401	207	135-3402-001	202	141-0694-002	214
131-6333-401	237	133-3304-406	207	135-3402-101	200	141-0694-012	214
131-6333-406	237	133-3402-001	207	135-3402-111	201	141-0694-062	222
131-6403-001	237	133-3402-006	207	135-3403-001	203	142-0002-221	252
131-6403-006	237	133-3402-101	210	135-3403-101	201	142-0002-226	252
131-6403-101	238	133-3402-106	210	135-3404-001	203	142-0002-811	253
131-6403-106	238	133-3403-001	207	135-3404-101	201	142-0002-821	254
131-6404-001	237	133-3403-006	207	135-3433-001	203	142-0003-201	252

142-0003-206	252	142-0307-016	219	142-0693-051	216	142-4408-101	224
142-0003-231	252	142-0307-401	225	142-0693-056	216	142-4408-106	224
142-0003-236	252	142-0307-406	225	142-0693-101	213	142-4435-001	220
142-0003-241	252	142-0307-411	219	142-0693-106	213	142-4435-006	220
142-0003-246	252	142-0307-416	219	142-0694-001	214	142-4435-101	229
142-0003-301	252	142-0308-011	219	142-0694-006	214	142-4435-106	229
142-0003-306	252	142-0308-016	219	142-0694-011	214	142-4439-001	220
142-0003-801	253	142-0308-401	225	142-0694-016	214	142-4439-006	220
142-0003-811	253	142-0308-406	225	142-0694-021	215	142-4439-101	229
142-0004-201	252	142-0308-411	219	142-0694-026	215	142-4439-106	229
142-0004-206	252	142-0308-416	219	142-0694-031	215	142-5303-401	219
142-0004-211	252	142-0333-011	219	142-0694-036	215	142-5303-406	219
142-0004-216	252	142-0333-016	219	142-0694-041	215	142-5304-401	219
142-0004-221	252	142-0333-411	219	142-0694-046	215	142-5304-406	219
142-0004-226	252	142-0333-416	219	142-0694-051	216	142-5307-401	219
142-0004-301	252	142-0335-401	220	142-0694-056	216	142-5307-406	219
142-0004-306	252	142-0335-406	220	142-0694-101	213	142-5308-401	219
142-0004-801	253	142-0339-401	220	142-0694-106	213	142-5308-406	219
142-0004-811	253	142-0339-406	220	142-0761-801	228	142-5403-001	219
142-0007-801	253	142-0402-011	217	142-0761-811	228	142-5403-006	219
142-0007-811	253	142-0402-016	217	142-0761-821	228	142-5403-101	224
142-0008-801	253	142-0402-101	224	142-0761-831	228	142-5403-106	224
142-0008-811	253	142-0402-106	224	142-0761-841	228	142-5404-001	219
142-0093-801	253	142-0403-001	225	142-0761-851	228	142-5404-006	219
142-0093-806	253	142-0403-006	225	142-0761-861	228	142-5404-101	224
142-0094-801	253	142-0403-011	219	142-0761-871	228	142-5404-106	224
142-0094-806	253	142-0403-016	219	142-0761-881	228	142-5407-001	219
142-0096-801	253	142-0403-101	224	142-0761-891	228	142-5407-006	219
142-0096-806	253	142-0403-106	224	142-0771-821	228	142-5407-101	224
142-0102-401	230	142-0404-011	219	142-0771-831	228	142-5407-106	224
142-0102-406	230	142-0404-016	219	142-0791-801	227	142-5408-001	219
142-0103-401	230	142-0404-101	224	142-0791-811	227	142-5408-006	219
142-0103-406	230	142-0404-106	224	142-0791-821	227	142-5408-101	224
142-0107-401	230	142-0407-011	219	142-0801-421	216	142-5408-106	224
142-0107-406	230	142-0407-016	219	142-1403-001	219	142-5435-001	220
142-0202-011	230	142-0407-101	229	142-1403-006	219	142-5435-006	220
142-0202-016	230	142-0407-101	224	142-1404-001	219	142-5435-101	229
142-0202-101	231	142-0407-106	224	142-1404-006	219	142-5435-106	229
142-0202-106	231	142-0408-011	219	142-1407-001	219	142-5439-001	220
142-0203-011	230	142-0408-016	219	142-1407-006	219	142-5439-006	220
142-0203-016	230	142-0408-101	224	142-1408-001	219	142-5439-101	229
142-0203-101	231	142-0408-106	224	142-1408-006	219	142-5439-106	229
142-0203-106	231	142-0433-011	219	142-1408-006	219	142-9303-411	219
142-0207-011	230	142-0433-016	219	142-1701-821	227	142-9403-011	219
142-0207-016	230	142-0433-016	219	142-1701-831	227	142-9403-101	224
142-0207-101	231	142-0433-101	224	142-4303-401	219	142-9404-011	219
142-0207-106	231	142-0433-106	224	142-4303-406	219	142-9404-101	224
142-0302-011	217	142-0435-001	220	142-4304-401	219	142-9407-001	219
142-0302-016	217	142-0435-006	220	142-4304-406	219	142-9407-101	224
142-0302-401	225	142-0435-101	229	142-4307-401	219	145-0693-001	212
142-0302-406	225	142-0435-106	229	142-4307-406	219	145-0693-002	212
142-0302-431	217	142-0439-001	220	142-4308-401	219	145-0694-001	212
142-0302-436	217	142-0439-006	220	142-4308-406	219	145-0694-002	212
142-0303-011	219	142-0439-101	229	142-4403-001	219	146-0403-007	256
142-0303-016	219	142-0439-106	229	142-4403-006	219	146-0403-107	255
142-0303-401	225	142-0593-001	214	142-4403-101	224	146-0404-007	256
142-0303-406	225	142-0593-006	214	142-4403-106	224	146-0404-107	255
142-0303-411	219	142-0593-401	214	142-4404-001	219	CPN-1	241
142-0303-416	219	142-0593-406	214	142-4404-006	219	CPN-110	241
142-0303-461	219	142-0593-411	214	142-4404-101	224	CPN-142T	241
142-0304-011	219	142-0593-416	214	142-4404-106	224	CPN-16	241
142-0304-016	219	142-0594-001	214	142-4407-001	219	CPN-17	241
142-0304-401	225	142-0594-006	214	142-4407-006	219	CPN-2	241
142-0304-406	225	142-0594-401	214	142-4407-101	224	CPN-68-1	240
142-0304-411	219	142-0594-406	214	142-4407-106	224	CPN-68-13	240
142-0304-416	219	142-0693-001	214	142-4408-001	219	CPN-68-8	240
142-0307-011	219	142-0693-006	214	142-4408-006	219	CPN-8	241

For more information, please contact customer service at (507) 833-8822 or (800) 247-8256 • cinch.com

Illustrations are shown in inches (millimeters).

MMCX Right Angle Plug for .086 (2.18) Semi-Rigid Cable

1. Identify piece parts. (2 piece parts)
2. Strip cable to dimensions shown. Do not nick center conductor.
3. Insert cable into body making certain that jacket bottoms on the connector body. Fixture cable and assembly to prevent movement during soldering.
4. Solder center conductor to contact as shown. Use a minimum amount of solder for a good joint.
5. Solder body to cable as shown. Use a minimum amount of heat to minimize cable insulation movement.
6. Press end cap into body access port using .156 (3.96) diameter flat punch or Johnson assembly tool 141-0000-910.

Cable Group	Part No.
RG-405/U (.086 Semi-Rigid)	135-3693-101

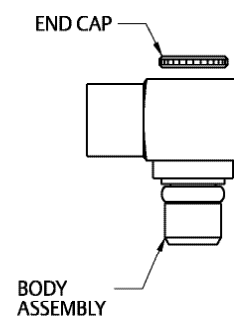
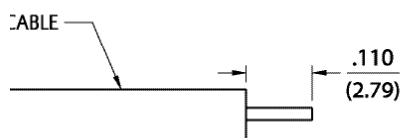
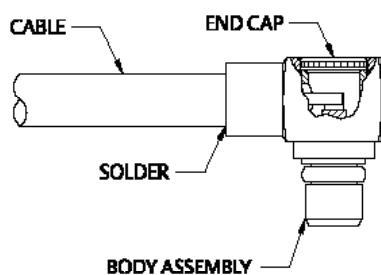
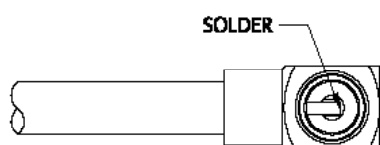

MMCX Right Angle Plug for RG-178 and RG-316 Size Flexible Cable

1. Identify piece parts. (3 piece parts)
2. Strip cable jacket to dimensions shown. Do not nick braid or center conductor during strip operations. Tin center conductor. Slide crimp sleeve onto cable jacket.
3. Flair braid and assemble crimp stem of body subassembly under braid onto cable making certain that the cable center conductor enters contact slot as shown. Arrange braid uniformly around crimp stem. Slide crimp sleeve over braid and crimp securely using recommended crimp hex.
4. Solder center conductor to contact through rear access port. Use a minimum amount of solder for a full fillet joint.
5. Press end cap into body access port using .156 (3.96) diameter flat punch or Johnson assembly tool 141-0000-91.

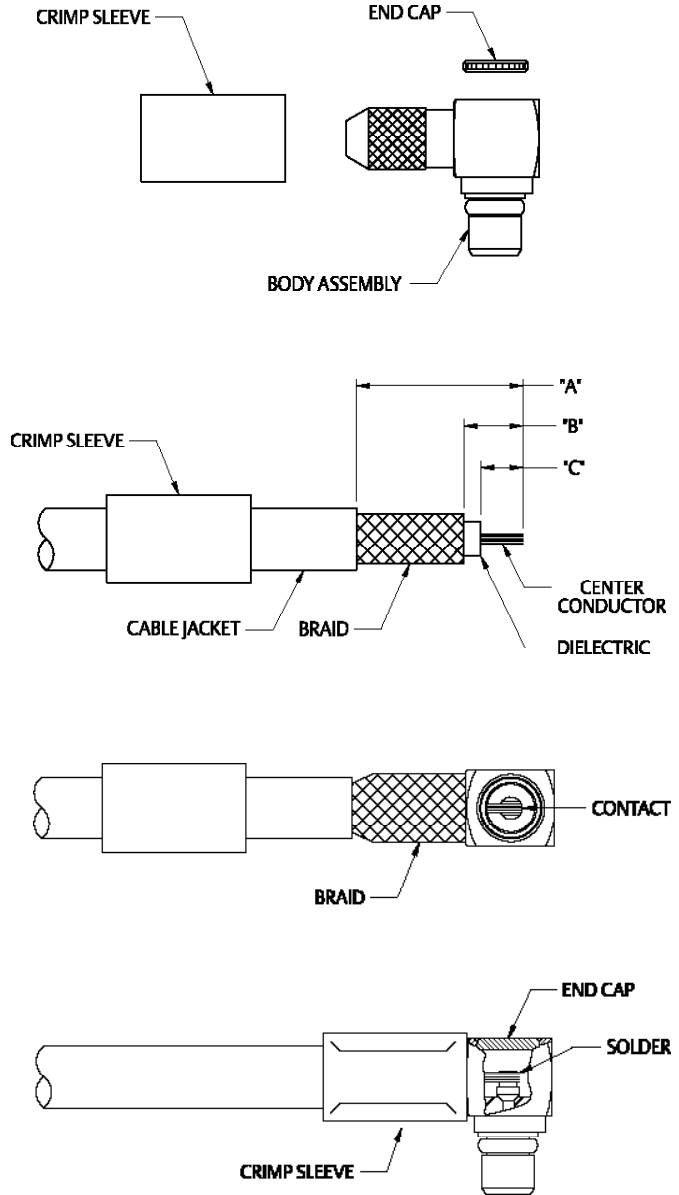

Cable Group	Part No.	Sleeve Hex	"A"	"B"	"C"
RG-178, 196	135-9402-111	.105 (2.67)	.310	.100	.035
RG-316/U, 188, 187, 179	135-9403-101	.128 (3.25)	.295	.105	.075

For more information, please contact customer service at (507) 833-8822 or (800) 247-8256 • cinch.com
 Illustrations are shown in inches (millimeters).

MMCX Right Angle Plug for .047 (1.20) Diameter and RG-178 Size Flexible Cable with Crimp Insert

1. Identify piece parts. (3 piece parts)
2. Strip cable jacket to dimensions shown. Do not nick braid or center conductor during strip operations.
3. Slide crimp insert over braid and against jacket. Fold braid around crimp insert as shown. Strip cable dielectric to dimension shown. Tin center conductor.
4. Slide body assembly over cable and crimp insert, then seat firmly so cable dielectric butts against contact as shown. Crimp body using recommended crimp hex. Maintain forward pressure on cable while crimping.
5. Solder contact to center conductor through rear access port. Use a minimum amount of solder for a full fillet joint.
6. Press end cap into access port using .156 (3.96) diameter flat punch or Johnson assembly tool 141-0000-910.

Cable Group	Part No.	"L"	Crimp Hex
.047 Flexible	135-3436-101	.140 (3.56)	.105 (2.67)
RG-178/U, 196	135-3402-101	.188 (4.78)	.105 (2.67)
.047 Flexible	135-9436-101	.140 (3.56)	.105 (2.67)

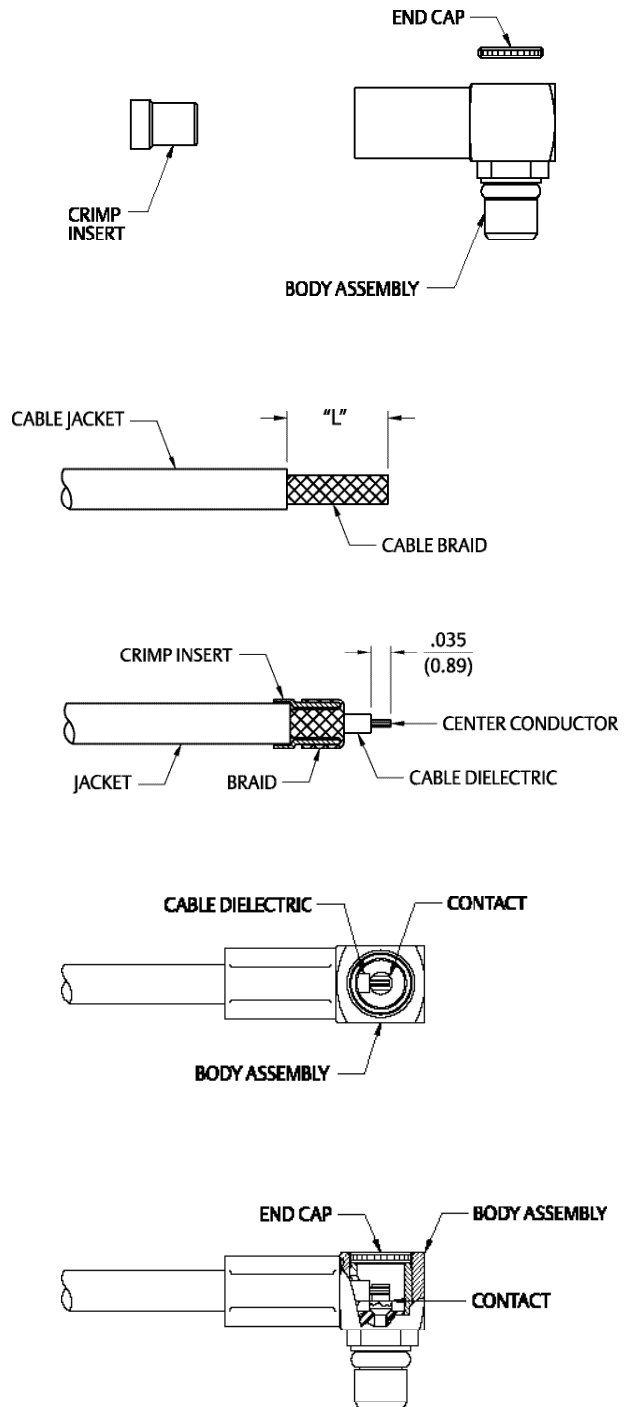

MMCX Right Angle Plug for RG-178, RG-316, RG-316 DS and RG-179 Size Flexible Cable

1. Identify connector parts. (3 piece parts)
2. Strip cable jacket to dimensions shown. Do not nick braid or center conductor during strip operations. Tin center conductor. Slide crimp sleeve onto cable jacket.
3. Flair braid and assemble crimp stem of body subassembly under braid onto cable making certain that the cable center conductor enters contact slot as shown. Arrange braid uniformly around crimp stem. Slide crimp sleeve over braid and crimp securely using recommended crimp hex.
4. Solder center conductor to contact through rear access port. Use a minimum amount of solder for a full fillet joint.
5. Press end cap into body access port using .156 (3.96) diameter flat punch or Johnson assembly tool 141-000-910.

Cable Group	Part No.	Crimp Hex	"A"	"B"	"C"
RG-178, 196	135-3402-111	.105 (2.67)	.310	.100	.035
RG-316/U, 188, 187, 179	135-3403-101	.128 (3.25)	.295	.105	.075
RG-316 DS, 188 DS	135-3404-101	.151 (3.83)	.295	.105	.075

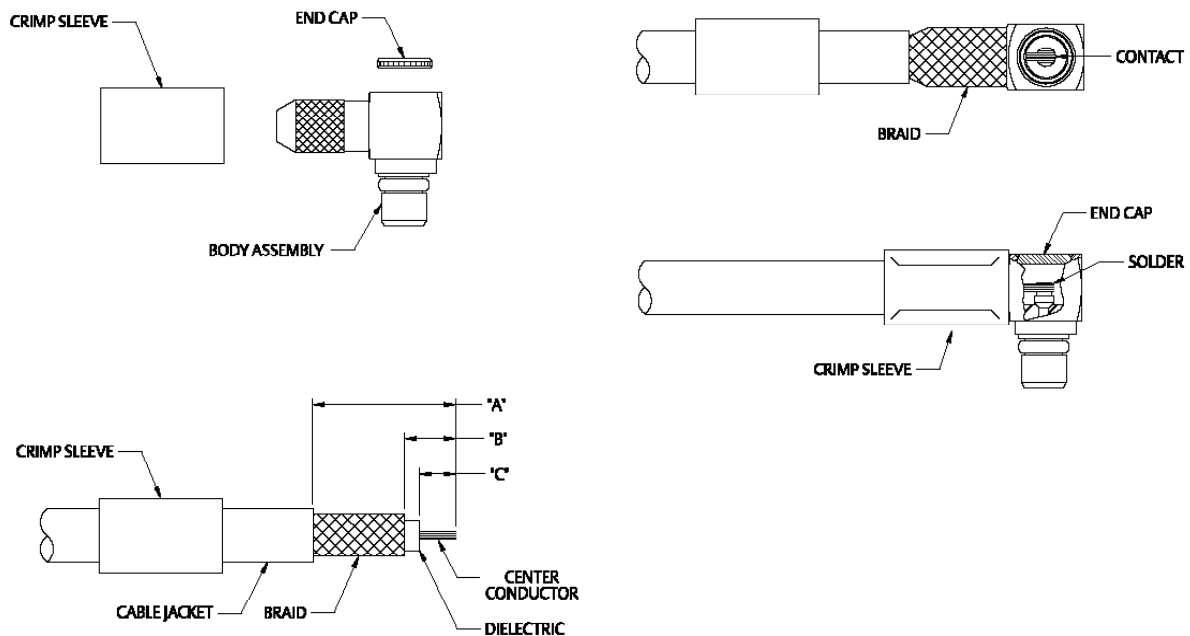

For more information, please contact customer service at (507) 833-8822 or (800) 247-8256 • cinch.com

Illustrations are shown in inches (millimeters).

MMCX Straight Plug for .047 (1.19) Diameter and RG-178 Size Flexible Cable

1. Identify piece parts. (3 piece parts)
2. Strip cable jacket to dimensions shown. Do not nick braid or center conductor during strip operations.
3. Slide crimp insert over braid and against jacket. Fold braid around crimp insert as shown. Strip dielectric to dimension shown. Tin center conductor if contact is to be soldered attached. Do not tin center conductor if contact is to be crimp attached.
4. Assemble contact assembly onto cable as shown.
Solder attachment: Solder contact to center conductor. Care should be taken that excess solder is not applied.
Crimp attachment: Crimp contact to center conductor using Johnson hand tool 140-0000-952 and die set 140-000-953. Crimp location should be centered between end of contact and cross-hole. Crimp attachment to solid center conductor cables is not recommended.
5. Slide body assembly over contact and crimp insert, then seat firmly as shown. Crimp body using recommended crimp die hex. Maintain forward pressure on cable while crimping.

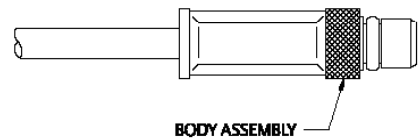
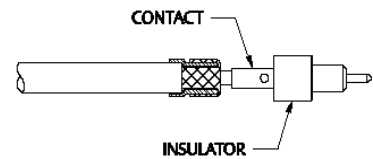
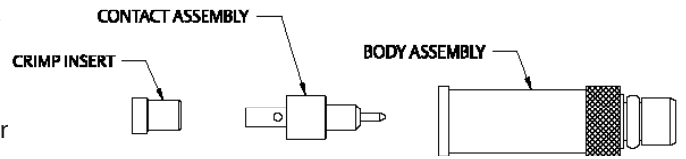
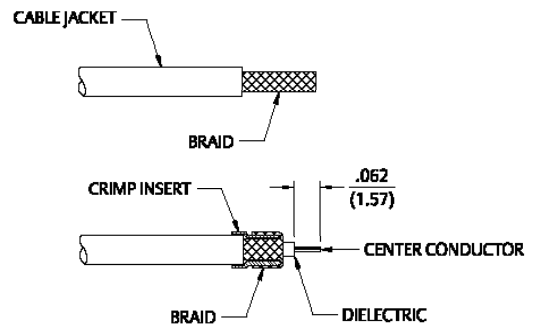

Cable Group	Part No.	Strip Length	Crimp Hex
.047 Flexible	135-3436-001	.135 (3.43)	.105 (2.67) x .250 (6.35) W
RG-178/U, 196	135-3402-001	.184 (4.67)	.105 (2.67) x .250 (6.35) W

MMCX Straight Plug for RG-316, RG-179 and RG-316 DS Size Flexible Cable

1. Identify connector parts. (3 piece parts)
2. Strip cable jacket to dimensions shown. Do not nick braid or center conductor during strip operations. Tin center conductor if contact will be solder attached. Do not tin center conductor if contact is to be crimp attached. Slide crimp sleeve onto cable jacket.
3. Assemble contact onto cable as shown.
Solder attachment: Solder contact to center conductor. Care should be taken that excess solder is not applied.
Crimp attachment: Crimp contact to center conductor using Johnson hand tool 140-0000-952 and die set 140-0000-953. Crimp location should be centered between end of contact and cross-hole. Crimp attachment to solid center conductor cables is not recommended.
4. Slide body assembly over contact and under braid, then seat firmly onto contact as shown. The body assembly will "snap" over the contact barb. The cable may have to be held in a soft jawed clamping fixture. Slide crimp sleeve forward and crimp using recommended crimp die hex.

Cable Group	Part No.	Crimp Hex
RG-316/U, 188, 161, 174	135-3403-001	.128 (3.25)
RG-316 DS, 188 DS, 187 DS	135-3404-001	.151 (3.83)
RG-179/U, 187	135-3433-001	.128 (3.25)

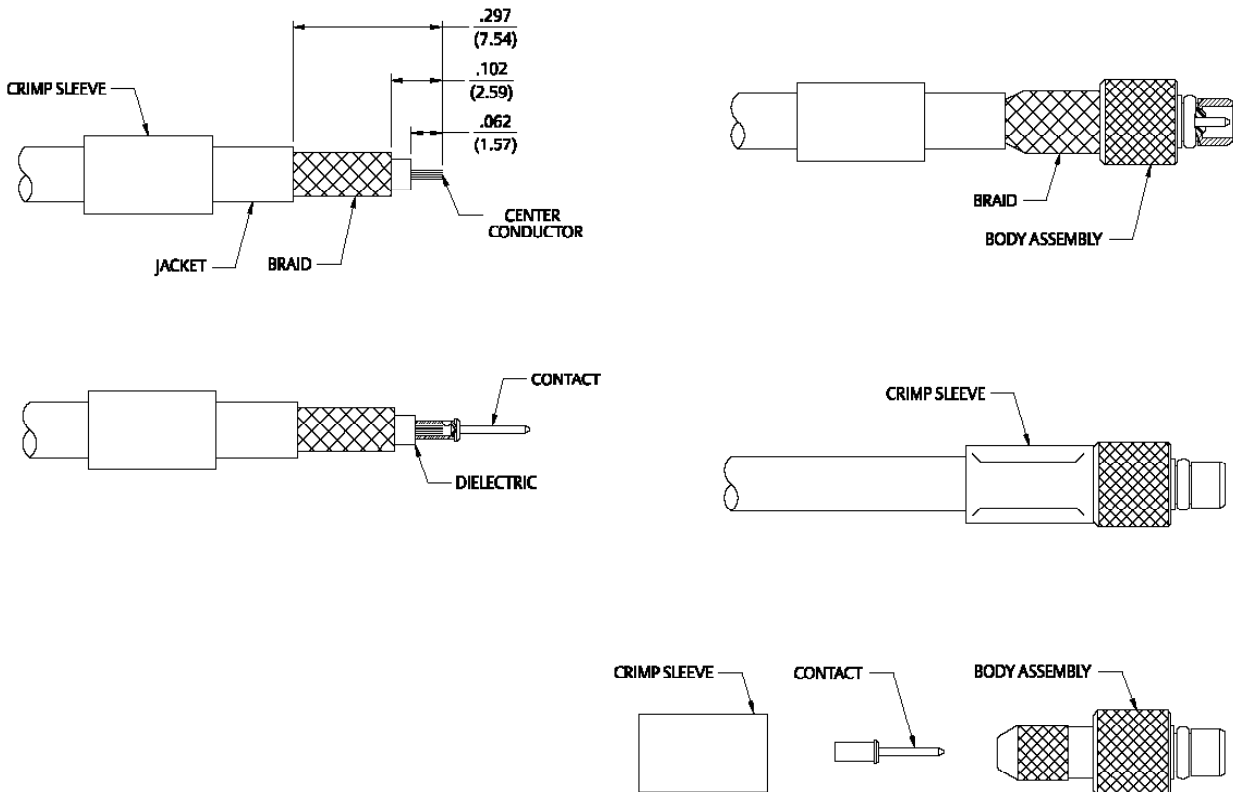

For more information, please contact customer service at (507) 833-8822 or (800) 247-8256 • cinch.com

Illustrations are shown in inches (millimeters).

MMCX Straight Jack for RG-316, RG-316 DS and RG-179 Size Flexible Cable

1. Identify connector parts. (3 piece parts)
2. Strip cable jacket to dimensions shown. Do not nick braid or center conductor during strip operations. Tin center conductor if contact will be solder attached. Do not tin center conductor if contact is to be crimp attached. Slide crimp sleeve onto cable jacket.
3. Assemble contact onto cable.

Solder attachment: Solder contact to center conductor. Care should be taken that excess solder is not applied.

Crimp attachment: Crimp contact to center conductor using Johnson hand tool 140-0000-952 and die set 140-0000-953. Crimp location should be centered between end of contact and cross-hole. Crimp attachment to solid center conductor cables is not recommended.
4. Slide body assembly over contact and under braid, then seat firmly onto contact. The body assembly will "snap" over the contact barb. The cable may have to be held in a soft jawed clamping fixture. Slide crimp sleeve forward and crimp using recommended crimp die hex.

Cable Group	Part No.	Crimp Hex
RG-316/U, 188, 161, 174	135-3303-001	.128 (3.25)
RG-316 DS, 188 DS, 187 DS	135-3304-001	.151 (3.83)
RG-179/U, 187	135-3333-001	.128 (3.25)
RG-316/u, 188, 174	135-9403-001	.128 (3.25)
RG-316 DS, 188 DS	135-9404-001	.151 (3.83)

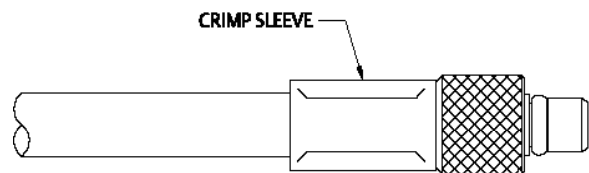
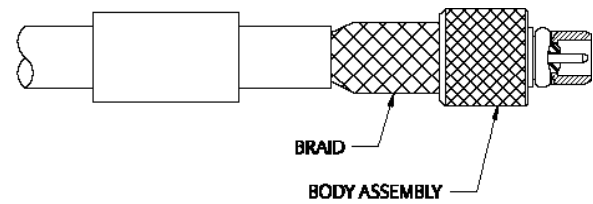
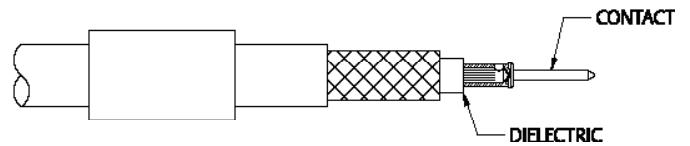
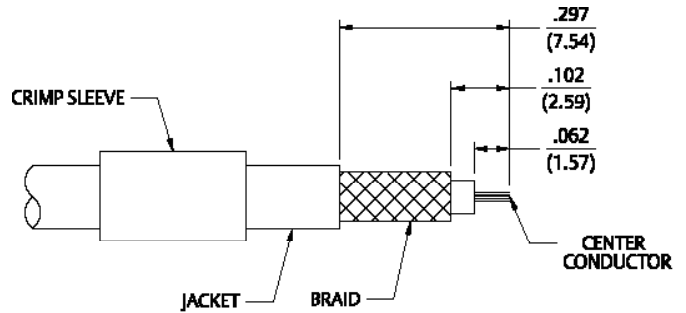
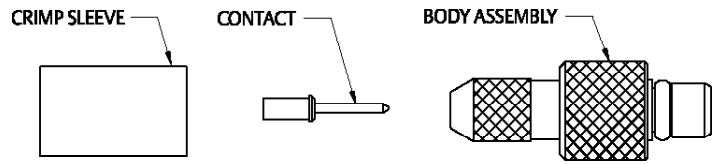

MMCX Straight Jack for .047 Diameter and RG-178 Size Flexible Cable

1. Identify connector parts. (3 piece parts – except bulkhead jack as shown.)
2. Strip cable jacket to dimensions shown. Do not nick braid or center conductor during strip operations.
3. Slide crimp insert over braid and against jacket, fold braid around crimp insert. Strip dielectric to dimension shown. Tin center conductor if contact will be solder attached. Do not tin center conductor if contact is to be crimp attached.
4. Assemble contact assembly onto cable as shown.
Solder attachment: Solder contact to center conductor. Care should be taken that excess solder is not applied.
Crimp attachment: Crimp contact to center conductor using Johnson hand tool 140-0000-952 and die set 140-0000-953. Crimp location should be centered between end of contact and cross-hole. Crimp attachment to solid center conductor cables is not recommended.
5. Slide body assembly over contact and crimp insert, then seat firmly onto contact. Crimp body using recommended crimp hex. Bulkhead jack requires 140-000-951 dieset. Maintain forward pressure on cable while crimping.

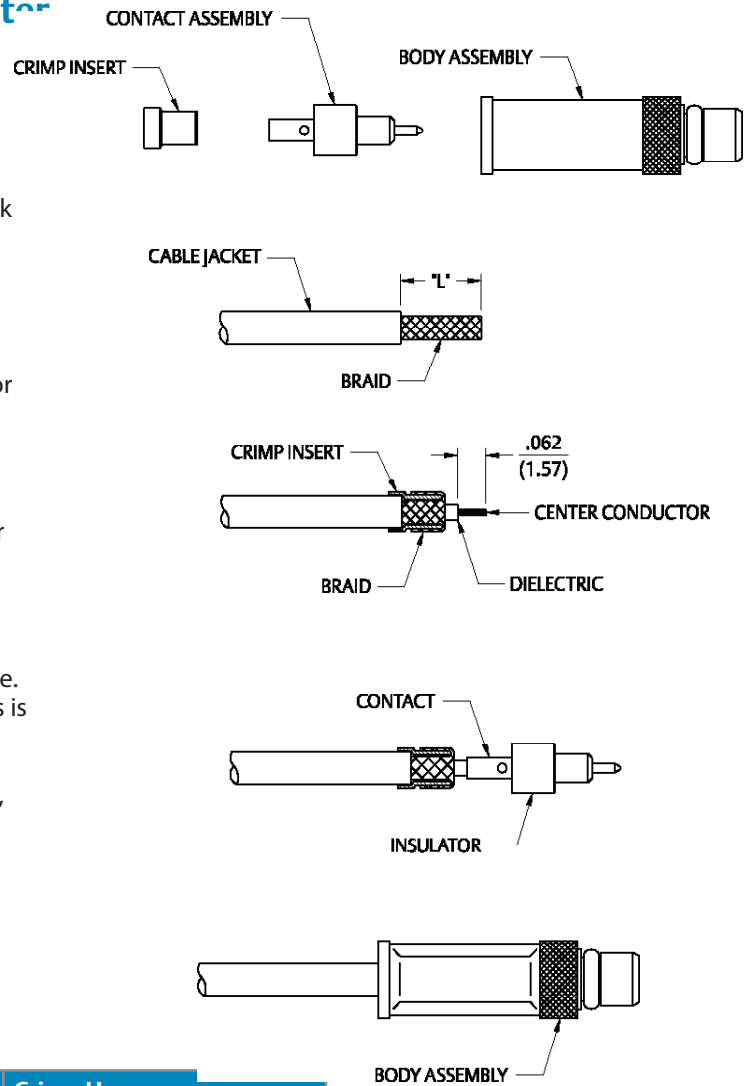

Cable Group	Part No.	"L"	Crimp Hex
.047 Flexible	135-3336-001	.135 (3.43)	.105 (2.67) x .250 (6.35) W
	135-3336-401	.135 (3.43)	.105 (2.67) x .250 (6.35) W
RG-178/U, 196	135-3302-001	.185 (4.67)	.105 (2.67) x .250 (6.35) W
	135-3302-401	.185 (4.67)	.105 (2.67) x .250 (6.35) W
.047 Flexible	135-9436-001	.135 (3.43)	.105 (2.67) x .250 (6.35) W
RG-178/U, 196	135-9402-001	.185 (4.67)	.105 (2.67) x .250 (6.35) W

For more information, please contact customer service at (507) 833-8822 or (800) 247-8256 • cinch.com

Illustrations are shown in inches (millimeters).

MCX Solder Type Straight Plug for Semi-Rigid Cable

1. Identify connector parts. (2 piece parts)
2. Strip cable to dimensions shown. Do not nick center conductor.
3. Place center contact on center conductor making sure contact bottoms against cable insulation. Solder center conductor to center contact through solder hole. Solder must not be allowed to run on outside of contact. Use a minimum amount of solder for a good joint. .020 (0.51) diameter solder is recommended. Trim excess insulation.
4. Insert contact and cable into body assembly making sure cable is bottomed against insulator in body. Solder body to cable. Use a minimum amount of heat to minimize cable insulation movement.

Cable Group	Part No.
RG-405/U (.086 Semi-Rigid)	133-3693-001
	133-3693-006

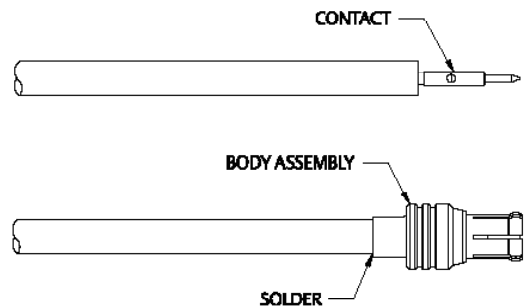
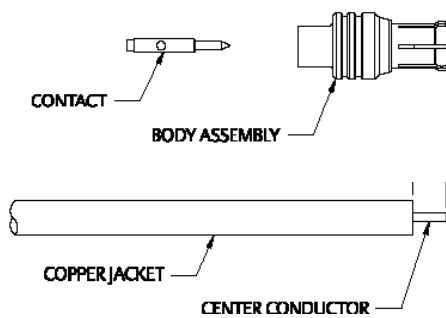

MCX Solder Type Right Angle Plug for Semi-Rigid Cable

1. Identify connector parts. (3 piece parts)
2. Strip cable to dimensions shown. Do not nick center conductor.
3. Insert cable into body making sure cable insulation bottoms on center contact. Solder center conductor to contact through the rear access port. Use a minimum amount of solder for a good joint. .020 (0.51) diameter solder is recommended.
4. Solder body to cable. Use a minimum amount of heat to minimize cable insulation movement. Assemble insulator then place expansion cap in access port and seat with a .156 (3.96) diameter punch or hand tool 141-0000-908.

Cable Group	Part No.
RG-405/U (.086 Semi-Rigid)	133-3693-101
	133-3693-106

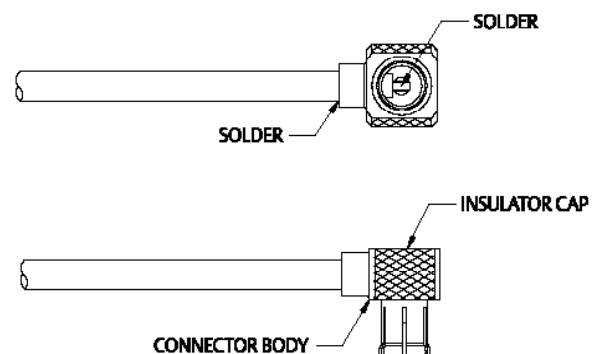
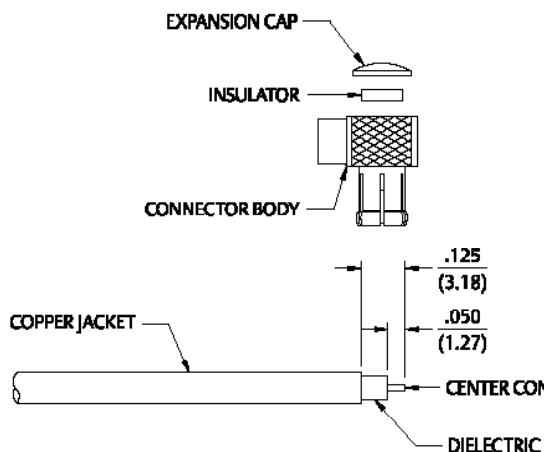

MCX Crimp Type Straight Connectors for Flexible Cable

1. Identify connector parts. (3 piece parts – except bulkhead)
2. Strip cable to dimensions shown. Do not nick braid or center conductor. Tin center conductor if contact is to be solder attached. Do not tin center conductor if contact is to be crimp attached. Slide heat shrink (as applicable) and crimp sleeve onto jacket of cable.
3. Assemble contact onto cable as shown.

Solder attachment. Solder contact to center conductor through solder hole using .020 (0.51) diameter solder. Use a minimum of solder for a good joint.

Crimp attachment. Crimp contact to center conductor using a miniature 8 indent tool 140-0000-970 with positioner 140-0000-971. Crimp location should be centered between end of contact and cross hole. Crimp attachment to solid center conductor cable is not recommended.
4. Flair braid and slide body assembly over contact and under braid. Then seat body assembly firmly onto contact. (RG-178 is non-captivated, RG-316 incorporates snap-fit captivation.) The cable may have to be held in a clamping fixture. Arrange braid uniformly around crimp stem. Slide crimp sleeve forward and crimp using recommended crimp tool. Slide heat shrink forward and shrink (as applicable).

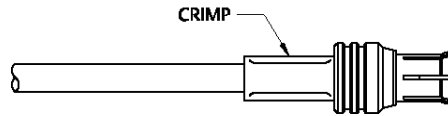
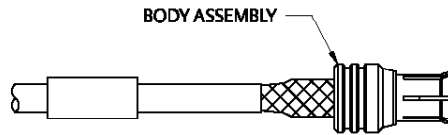
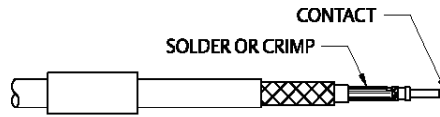
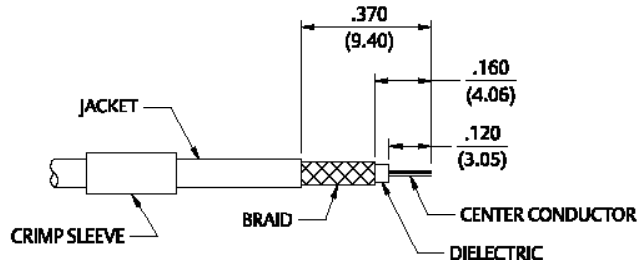
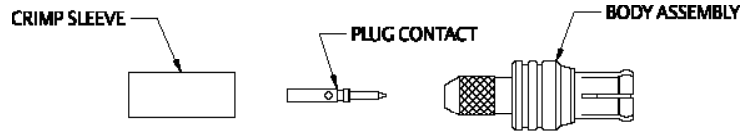

Cable Group	Part No.	Crimp Hex
RG-178/U, 196	133-3302-001/006	.105 (2.67)
	133-3302-401/406	.105 (2.67)
RG-316/U, 161, 174, 188	133-3303-001/006	.128 (3.25)
	133-3303-401/406	.128 (3.25)
RG-316 DS, 188 DS	133-3304-001/006	.151 (3.83)
	133-3304-401/406	.151 (3.83)
RG-178/U, 196	133-3402-001/006	.105 (2.67)
RG-316/U, 161, 174, 188	133-3403-001/006	.128 (3.25)
RG-316 DS, 188 DS	133-3404-001/006	.151 (3.83)
RG-179/U, 187	133-3433-001/006	.128 (3.25)
RG-178/U, 196	133-5302-401/406	.105 (2.67)
RG-316/U, 161, 174, 188	133-5303-401/406	.128 (3.25)
RG-316 DS, 188 DS	133-5304-401/406	.151 (3.83)
RG-178/U, 196	133-5402-001/006	.105 (2.67)
RG-316/U, 161, 174, 188	133-5403-001/006	.128 (3.25)
RG-316 DS, 188 DS	133-5404-001/006	.151 (3.83)
RG-316/U, 188, 174	133-9403-001	.128 (3.25)
RG-316 DS, 188 DS	133-9404-001	.151 (3.83)

For more information, please contact customer service at (507) 833-8822 or (800) 247-8256 • cinch.com

Illustrations are shown in inches (millimeters).

MCX Crimp Type Right Angle Plugs for Flexible Cable

1. Identify connector parts. (4 piece parts).
2. Strip cable to dimensions shown. Do not nick braid or center conductor. A wire stripper of correct size is recommended for this step. Twist stranded center conductor into tight bundle and tin (optional). Slide crimp sleeve onto cable as shown.
3. Flare braid and slide cable into body making certain that the cable dielectric bottoms against center contact. Solder: Solder center conductor to contact through the side access ports and hole in center contact. Use a minimum amount of solder for a full fillet joint. .015 (0.38) diameter solder is recommended. Crimp: Crimp Contact Attachment Crimp contact using 41-0000-924 dieset in 144-0000-900 tool frame.
4. Arrange braid uniformly around crimp stem. Slide crimp sleeve over braid and access ports. Crimp securely using recommended hex size and crimp tool.

Cable Group	Part No.	Sleeve Hex
RG-316/U, 188, 174	133-9403-101/104	.128 (3.25)
RG-316 DS, 188 DS	133-9404-101	.151 (3.83)
RG-178	133-9402-101	.105 (2.67)

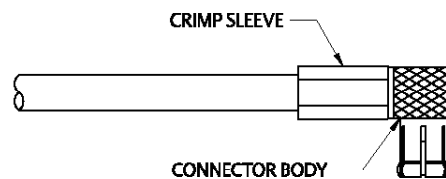
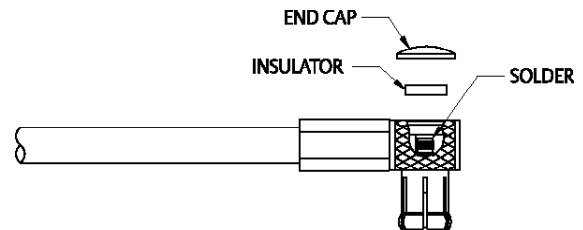
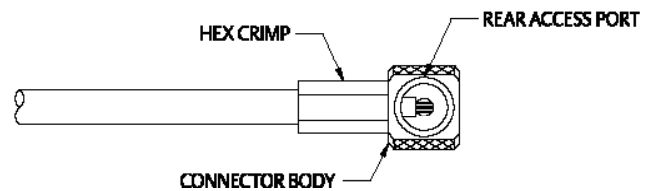
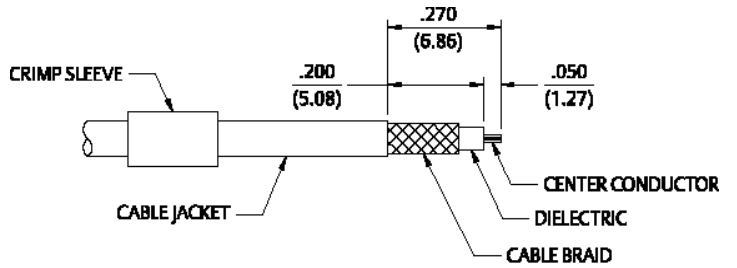
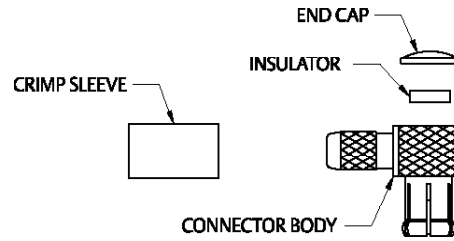

MCX Crimp Type Straight Connectors for Flexible Cable – 75 Ohm

1. Identify connector parts. (2 piece parts—except bulkhead)
2. Strip cable to dimensions shown. Do not nick braid or center conductor. A wire stripper of correct size is recommended for this step. Twist stranded center conductor into tight bundle and tin (optional). Slide crimp sleeve onto cable as shown.
3. Flare braid and slide cable into body making certain that the cable dielectric bottoms against center contact.

Solder: Solder center conductor to contact through the side access ports and hole in center contact. Use a minimum amount of solder for a full fillet joint. .015 (0.38) diameter solder is recommended.

Crimp: Crimp Contact Attachment: Crimp contact using 141-0000-924 dieset in 144-0000-900 tool frame.
4. Arrange braid uniformly around crimp stem. Slide crimp sleeve over braid and access ports. Crimp securely using recommended hex size and crimp tool.

Cable Group	Part No.	Crimp Hex
RG-179	133-8433-001	.128 (3.25)
RG-179 DS	133-8434-001	.151 (3.83)
RG-179	133-8333-001	.128 (3.25)
RG-179 DS	133-8334-001	.151 (3.83)
RG-179	133-8333-401	.128 (3.25)
RG-179 DS	133-8334-401	.151 (3.83)
BELDEN 735A	133-8445-001	.151 (3.83)

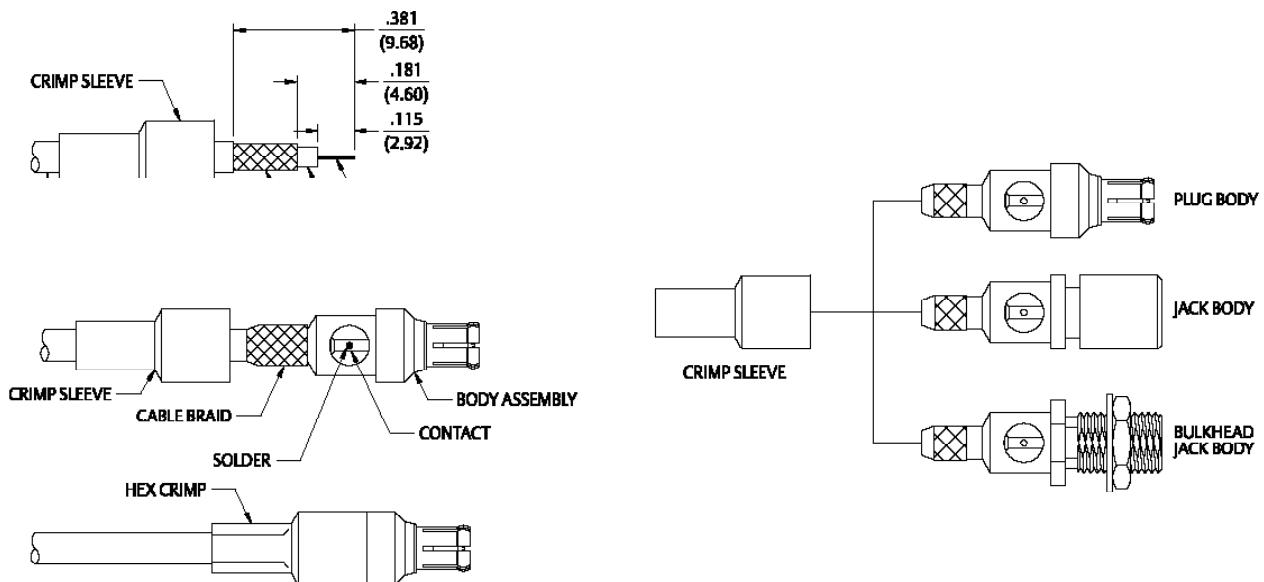

For more information, please contact customer service at (507) 833-8822 or (800) 247-8256 • cinch.com

Illustrations are shown in inches (millimeters).

MCX Crimp Type Right Angle Plugs for Flexible Cable – 50 Ohm

1. Identify connector parts. (4 piece parts except RG-58)
2. Strip cable to dimensions shown. Do not nick braid or center conductor. A wire stripper of correct size is recommended for this step. Twist stranded center conductor into tight bundle and tin (optional). Slide crimp sleeve onto cable shown.
3. Flair braid and slide cable into body making certain that the cable insulation bottoms on center contact. Arrange braid uniformly around crimp stem. Slide crimp sleeve over braid and crimp securely using recommended crimp tool.
4. Solder center conductor to contact through rear access port. Use a minimum amount of solder for a full fillet joint. .020 (0.51) diameter solder is recommended.
5. Assemble insulator, if applicable; then place expansion cap in access port and seat with .156 (3.96) diameter flat punch or MCX hand assembly tool 141-0000-908. Shrink heat shrink tubing over crimp sleeve if applicable.

Cable Group	Part No.	"A"	"B"	"C"	Crimp Hex
RG-178/U, 196	133-3402-101/106	.050 (1.27)	.270 (6.86)	.200 (5.08)	.105 (2.67)
RG-188/U, 316, 161, 174	133-3403-101/106	.050 (1.27)	.270 (6.86)	.200 (5.08)	.128 (3.25)
RG-316 DS, 188 DS	133-3404-101/106	.050 (1.27)	.270 (6.86)	.200 (5.08)	.151 (3.83)
RG-179/U, 187	133-3433-101/106	.050 (1.27)	.270 (6.86)	.200 (5.08)	.128 (3.25)
RG-178/U, 196	133-5402-101/106	.050 (1.27)	.270 (6.86)	.200 (5.08)	.105 (2.67)
RG-188/U, 316, 161, 174	133-5403-101/106	.050 (1.27)	.270 (6.86)	.200 (5.08)	.128 (3.25)
RG-316 DS, 188 DS	133-5404-101/106	.050 (1.27)	.270 (6.86)	.200 (5.08)	.151 (3.83)
RG-58/U, 303, 141	133-3407-101/106	.067 (1.70)	.295 (7.49)	.210 (5.33)	.213 (5.41)

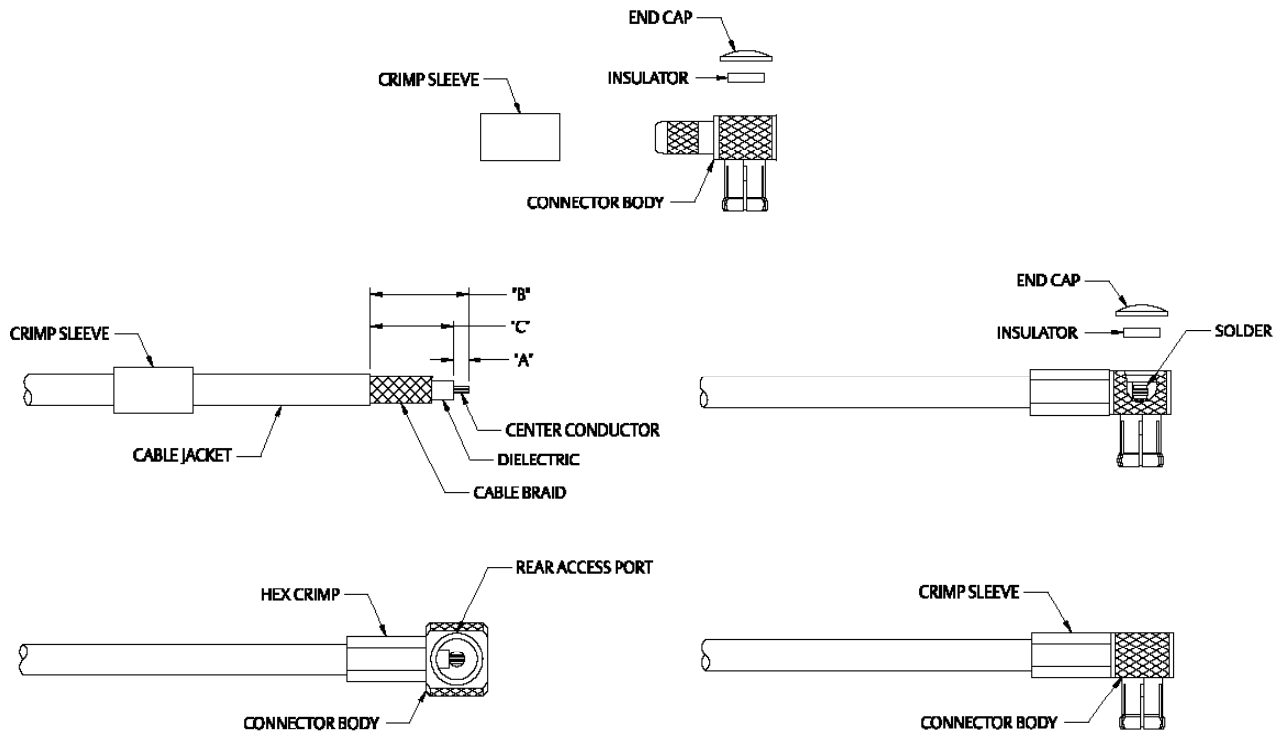

MCX Crimp Type Right Angle Plugs for Flexible Cable – 75 Ohm

1. Identify connector parts (3-piece parts).
2. Strip cable to dimensions shown. Do not nick braid or center conductor. A wire stripper of correct size is recommended for this step. Twist stranded center conductor into tight bundle and tin (optional). Slide crimp sleeve onto cable as shown.
3. Flair braid and slide cable into body making certain that the cable dielectric bottoms on center contact. Arrange braid uniformly around crimp stem. Slide crimp sleeve over braid and crimp securely using recommended crimp tool.
4. Solder center conductor to contact through rear access port. Use a minimum amount of solder for a full fillet joint. .020 (0.51) diameter solder is recommended.
5. Place expansion cap in access port and seat with .156 (3.96) diameter flat punch or MCX hand assembly tool 141-0000-908. Shrink heat shrink tubing over crimp sleeve if applicable.

Cable Group	Part No.	Crimp Hex
RG-179	133-8433-101	.128 (3.25)
RG-179 DS	133-8434-101	.151 (3.83)
BELDEN 735A	133-8445-101	.151 (3.83)

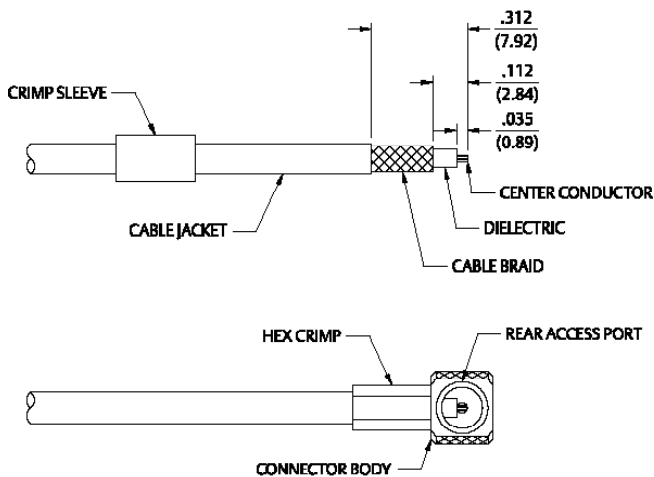
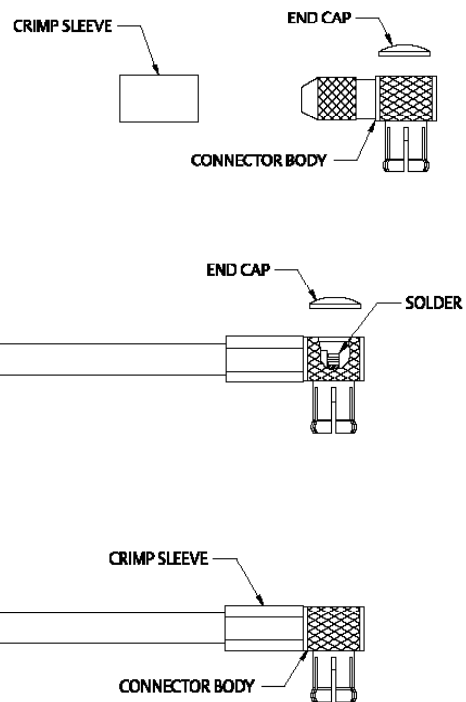

SMK Solder Type Straight Plugs for Semi-Rigid Cable

1. Identify connector parts (5 piece parts) and tools (5 tools.)
2. Strip cable jacket and dielectric to dimension shown.
3. Place center contact onto center conductor. Slide contact soldering tool onto contact. Clamp the cable contact and tool into cable soldering vise and solder contact to center conductor. High temperature solder, such as 95/5 Sn/Ag is recommended so that contact solder joint remains stable during body soldering operation. Solder paste is recommended for the contact solder joint to minimize excess solder. The assembled contact dimension should be as shown.
4. Remove excess solder from contact with a sharp blade and clean contact. Check for presence of excess solder by sliding body soldering tool over the contact. Remove soldering tool.
5. Place connector nut and body on cable. Place connector body soldering tool over contact and thread the coupling nut and connector body firmly to the tool. Place cable subassembly into cable soldering vise. Clamp cable and soldering tool securely to insure the cable dielectric expansion will not disturb the cable in the vise during soldering. Place hot soldering iron on the connector body sleeve and apply solder from the opposite side. A low temp solder, such as 60/40 Sn/Pb is recommended for the body solder joint. Allow the soldered joint to cool and remove from fixture. Check contact location to the body. The best electrical results are achieved when the contact location is within a tolerance of $.060 \pm .005$.
6. Place bead onto neck portion of the tool. Thread Bead Assembly tool firmly into the coupling nut. Push the tool's plunger between your thumb and fingers to assemble the bead. Check bead location. Assemble seal ring onto body.



Tool	145-0693-001/002 (for .086 Semi-Rigid)	145-0694-001/02 (for .141 Semi-Rig)
Semi-Rigid Cable Vise	140-0000-962	140-0000-962
Vise Stop	140-0000-968	140-0000-968
Bead Assy. Tool	140-0000-957	140-0000-957
Contact Soldering Tool	140-0000-960	140-0000-961
Body Soldering Tool	140-0000-958	140-0000-959
Cable Clamp Insert	140-0000-964	140-0000-965

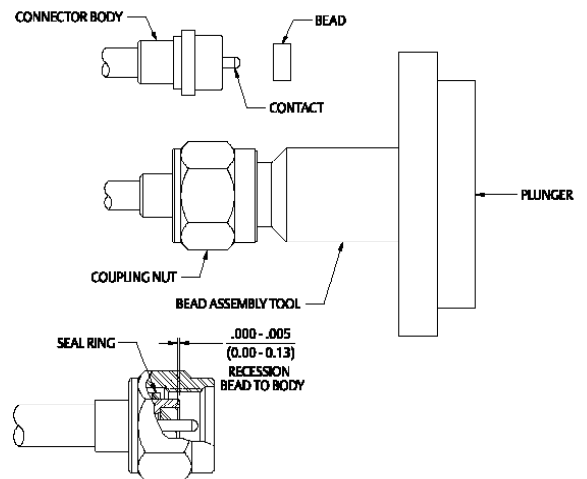
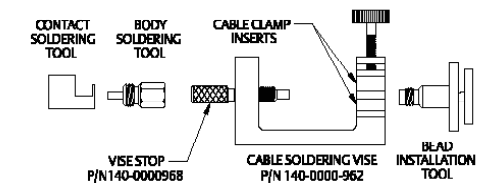
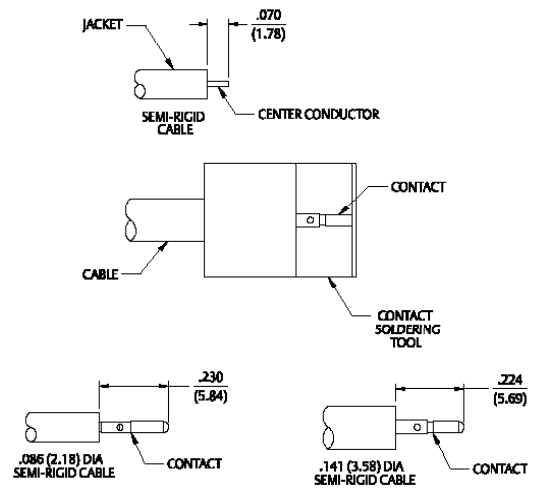
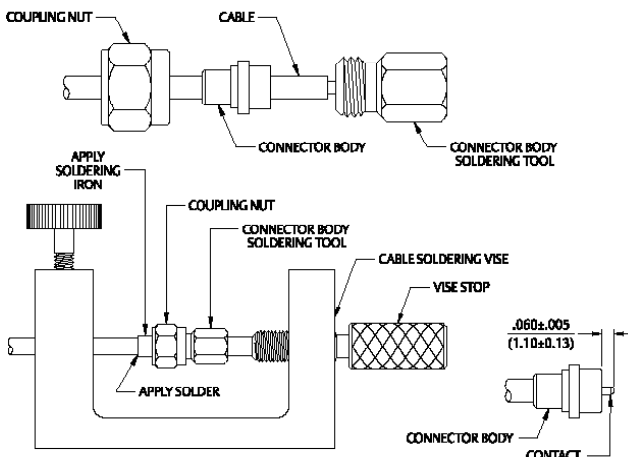
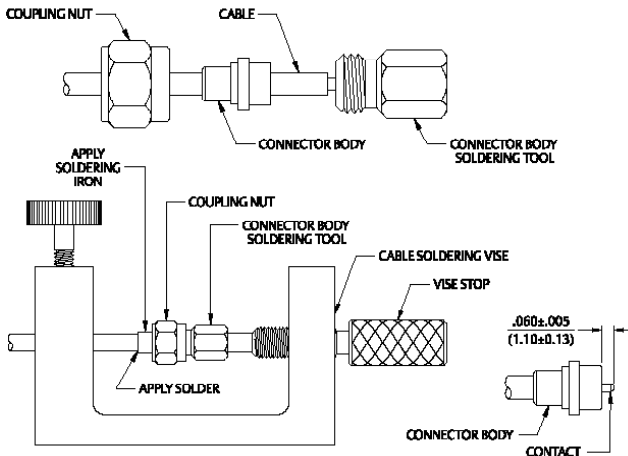

SMA Right Angle Solder Type Plug for Semi-Rigid Cable

1. Identify connector parts. (2 piece parts)
2. Strip cable to dimensions shown. Do not nick center conductor during strip operations.
3. Insert cable into body making certain that the cable jacket is butted against internal body shoulder and cable dielectric is started into cross hole. Solder center conductor to contact using 60/40 tin/lead solder as shown. Use a minimum amount of solder for a good joint.
4. Solder body to cable using 60/40 tin/lead solder as shown. Use a minimum of heat to minimize cable dielectric growth. Any growth of cable dielectric shall be flush with contact.
5. Press end cap into body access port using .187 (4.75) dia. flat punch.

Cable Group	Part No.	"A"	"B"
RG-405/U (.086 Semi-Rigid)	142-0693-101/106	.145 (3.68)	.075 (1.90)
RG-402/U (.141 Semi-Rigid)	142-0694-101/106	.170 (4.32)	.105 (2.67)

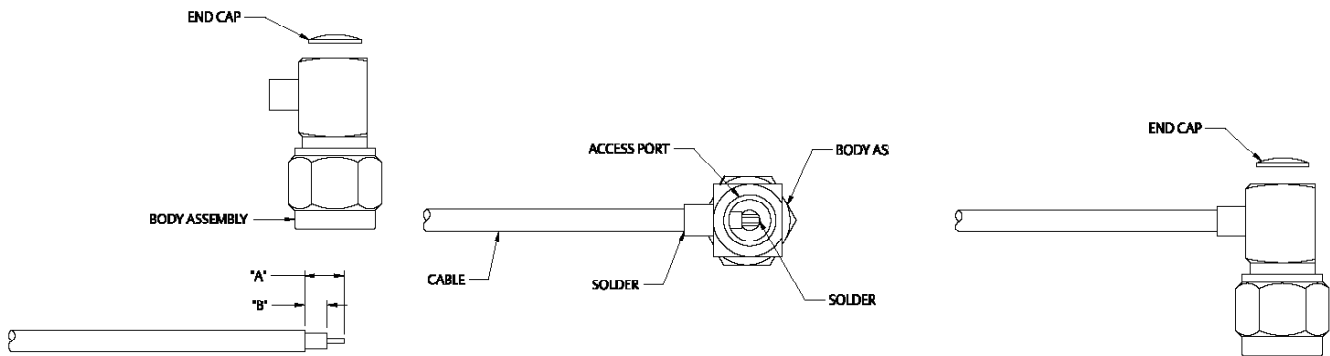

For more information, please contact customer service at (507) 833-8822 or (800) 247-8256 • cinch.com

Illustrations are shown in inches (millimeters).

SMA Solder Type Straight Jacks, Straight Plugs, and Straight Bulkhead Jacks for Semi-Rigid Cable

1. Identify connector parts. (2 piece parts)
2. Strip cable to dimensions shown. Do not nick center conductor
3. Place center contact on center conductor making sure contact bottoms against cable insulation. Solder center conductor through center contact through solder hole. Solder must not be allowed to run on outside of contact. Use a minimum amount of solder for a good joint. .020 (0.51) diameter solder is recommended. Trim excess insulation.
4. Insert contact and cable into body assembly making sure cable bottomed against insulator in body. Solder body to cable. Use a minimum amount of heat to minimize cable insulation movement.

Cable Group	Part No.	"A"
RG-405/U (.086 Semi-Rigid)	141-0593-001	.070 (1.78)
	141-0593-401	.070 (1.78)
	141-0693-002	.070 (1.78)
RG-402/U (.141 Semi-Rigid)	141-0594-001	.085 (2.16)
	141-0594-401	.085 (2.16)
	141-0694-002	.085 (2.16)
RG-405/U (.086 Semi-Rigid)	142-0593-001/006	.070 (1.78)
	142-0593-401/406	.070 (1.78)
	142-0593-411/416	.070 (1.78)
	142-0693-001/006	.070 (1.78)
RG-402/U (.141 Semi-Rigid)	142-0594-001/006	.085 (2.16)
	142-0594-401/406	.085 (2.16)
	142-0694-001/006	.085 (2.16)

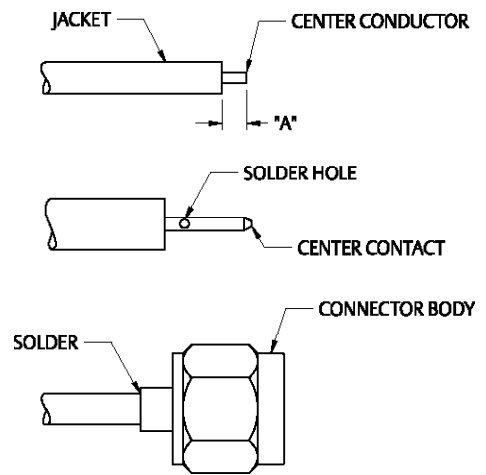
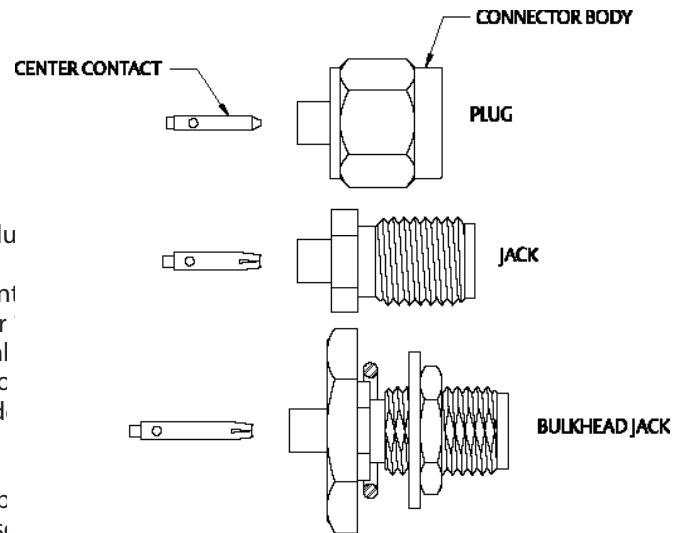

SMA Solder Type Straight Plugs for Semi-Rigid Cable

1. Identify connector parts. (2 piece parts)
2. Strip cable to dimensions shown. Do not nick center conductor. Bevel the cable center conductor per contact detail of SMA interface on page 48. Slide coupling nut onto cable as shown.
3. Insert cable into body making sure cable jacket is flush with front of body. Solder body to cable. Use a minimum amount of heat to minimize cable insulation movement. Trim expanded insulation flush with front of body or fixture body and cable during soldering to prevent cable insulation expansion.
4. Thread coupling nut over body.

Cable Group	Part No.
RG-402/U (.141 Semi-Rigid)	142-0694-011
	142-0694-016
	141-0694-012

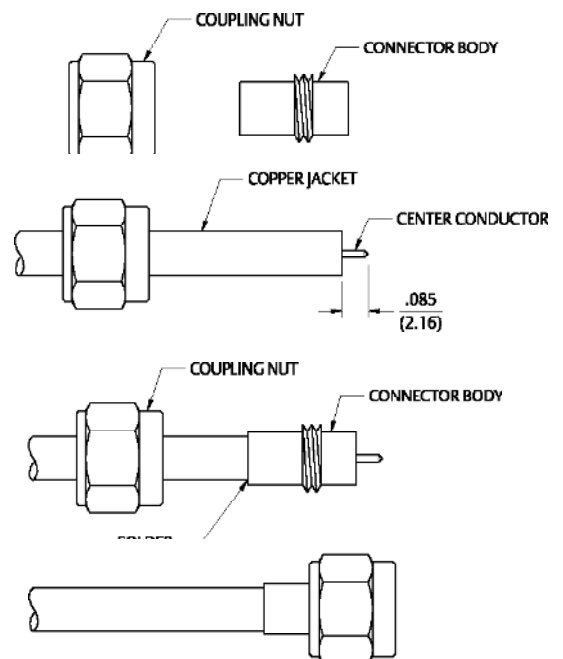

SMA Solder Type Straight Plugs for Semi-Rigid Cable

1. Identify connector parts. (2 piece parts)
2. Strip cable to dimensions shown. Do not nick center conductor. Bevel the cable center conductor per contact detail of SMA interface on page 48. Slide coupling nut onto cable as shown.
3. Insert cable into body making sure cable jacket is bottomed against shoulder inside of body. Solder body to cable. Use a minimum amount of heat to minimize cable insulation movement. Trim expanded insulation flush with front of body or fixture body and cable during soldering to prevent insulation expansion.
4. Thread coupling nut over body.

Cable Group	Part No.
RG-402/U (.141 Semi-Rigid)	142-0694-021
	142-0694-026
	142-0694-041
	142-0694-046

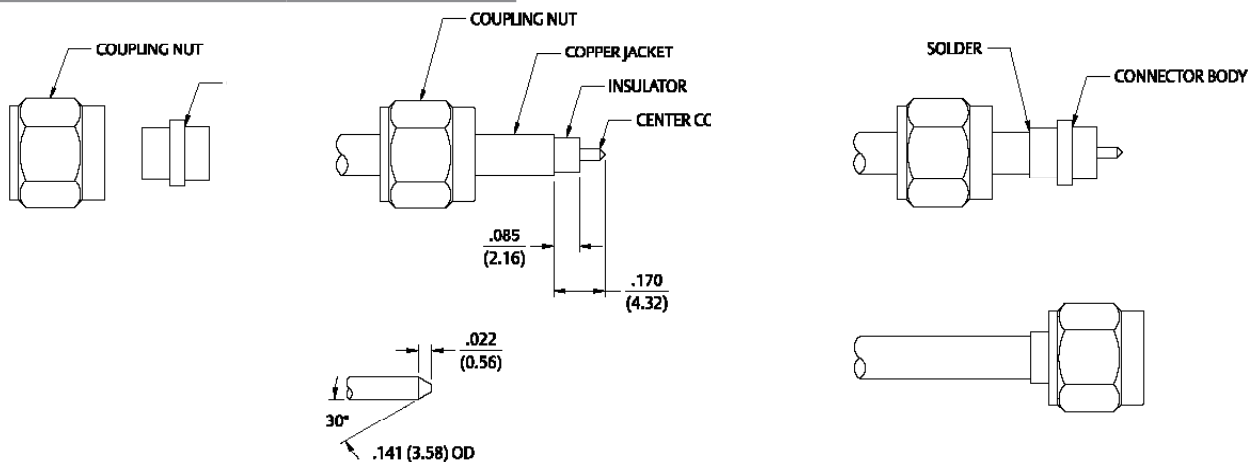

SMA Solder Type Straight Plugs for Semi-Rigid Cable

1. Identify connector parts. (3 piece parts)
2. Strip cable to dimensions shown. Do not nick center conductor. Bevel the cable center conductor per contact detail of SMA interface on page 48.
3. Insert cable into body making sure cable jacket is flush with front of body. Solder body to cable. Use a minimum amount of heat to minimize cable insulation movement. Trim expanded cable insulation flush with front of body or fixture body and cable during soldering to prevent insulation expansion.
4. Snap "C" spring onto connector body groove. Compress "C" spring using 141-0000-904 compression tool. Install coupling nut onto connector body. Nut should spin freely.

Cable Group	Part No.
RG-402/U (.141 Semi-Rigid)	

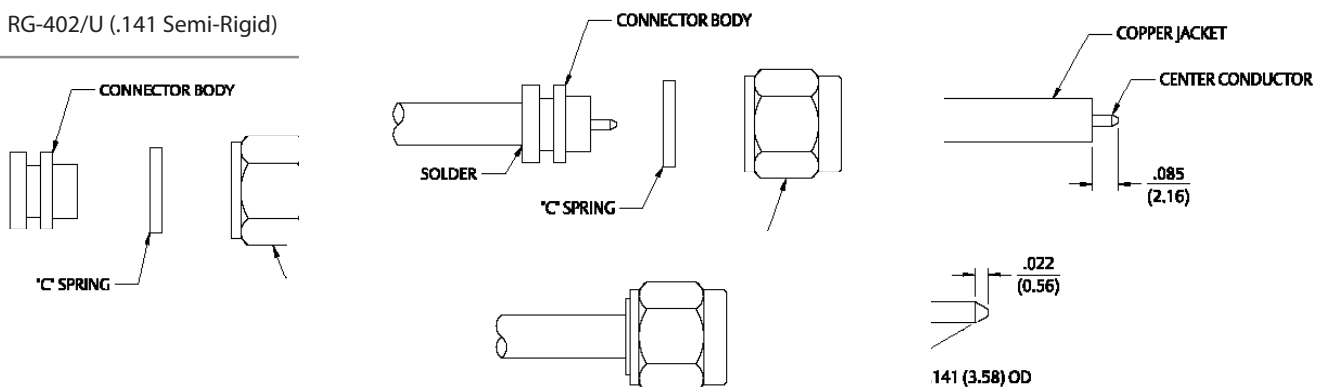

For more information, please contact customer service at (507) 833-8822 or (800) 247-8256 • cinch.com

Illustrations are shown in inches (millimeters).

SMA Solder Type Straight Plugs for Semi-Rigid Cable

1. Identify connector parts. (3 piece parts)
2. Strip cable to dimensions shown. Do not nick center conductor. Slide coupling nut onto cable as shown.
3. Place center contact on center conductor making sure contact bottoms against cable insulation. Solder center conductor to center contact through solder hole. Solder must not be allowed to run on outside of contact. Use a minimum amount of solder for a good joint. .020 (0.51) diameter solder is recommended. Trim excess insulation.
4. Insert contact and cable into body making sure cable is bottomed against insulator in body. Solder body to cable. Use a minimum amount of heat to minimize cable insulation movement.
5. Thread coupling nut over body

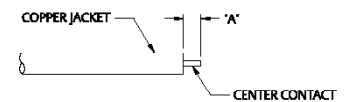
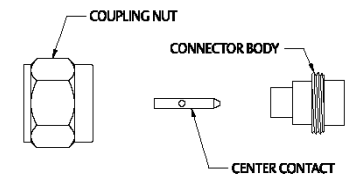
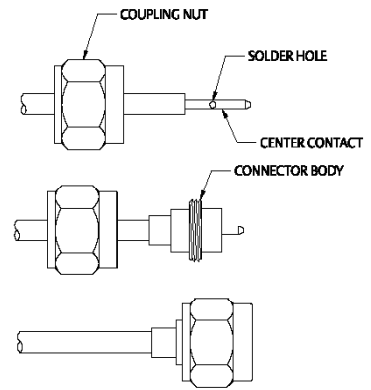

Cable Group	Part No.	"A"
RG-405/U (.086 Semi-Rigid)	142-0693-051	.070 (1.78)
	142-0693-056	.070 (1.78)
RG-402/U (.141 Semi-Rigid)	142-0694-051	.085 (2.16)
	142-0694-056	.085 (2.16)

SMA Solder Type Antenna Connector Plug for Flexible or Semi-Rigid Cable

1. Identify connector parts. (2 piece parts)
2. Strip cable to dimensions shown. Do not nick center conductor or braid on flexible cable.
3. **Flexible Cable Attachment:** Twist stranded center conductor into tight bundle and tin (optional). Slide cable into body, making sure cable insulation bottoms on center contact and braid fits inside stem. Solder center conductor to contact through the side access ports. Use a minimum amount of solder for a good joint. .020 (0.51) diameter solder is recommended. Solder braid to body. Use a minimum amount of solder to completely join the braid to the body.
Semi-Rigid Cable Attachments: Slide cable into body making certain cable insulation bottoms on center contact. Solder center conductor to contact through the side access ports. Use a minimum amount of solder for a good joint. .020 (0.51) diameter solder is recommended. Solder body to cable jacket. Use a minimum amount of heat to minimize cable insulation movement.

Cable Group	Part No.
RG-178/U, .047 Semi-Rigid	142-0801-421

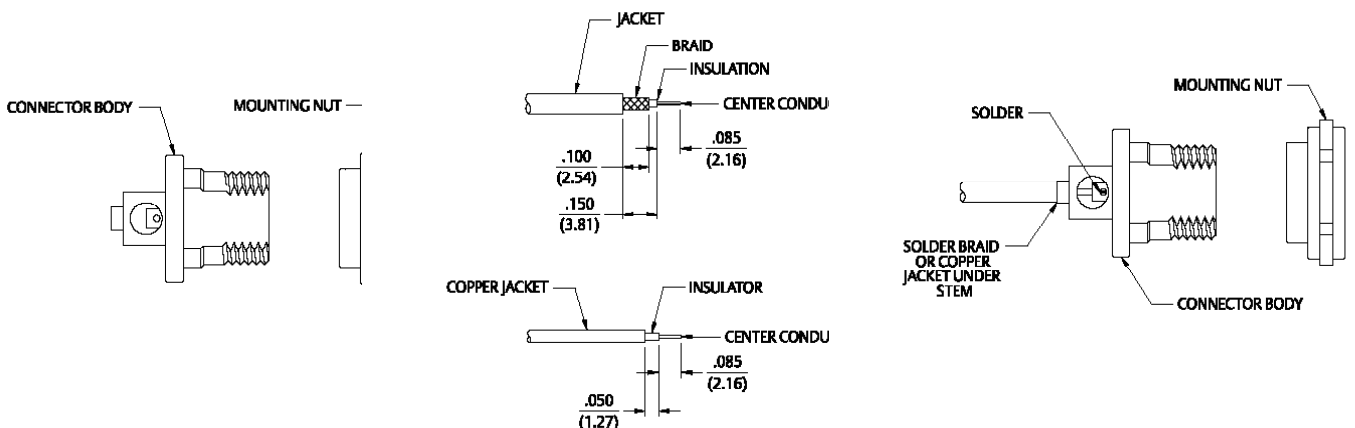

SMA 3-Piece Plug, Jack and Bulkhead Jack for RG-178 Flexible Cable

1. Identify piece parts. (4 piece parts plus nut and washer for bulkhead.)
2. Strip cable jacket and braid to dimensions shown. Do not nick braid during strip operations.
3. Slide crimp insert over braid and against jacket. Fold braid around crimp insert as shown. Strip dielectric to dimension shown. If cable is being manually stripped the rear insulator can be assembled and used as a guide. Do not nick center conductor during strip operation. Tin center conductor if contact is to be solder attached. Do not tin center conductor if contact is to be crimp attached.
4. Assemble rear insulator over cable dielectric and contact over center conductor as shown.
Solder attachment: Solder contact to center conductor using 60/40 tin/lead solder. Care should be taken that excess solder is not applied.
Crimp attachment: Crimp contact to center conductor using production tooling or hand tool 144-0000-910, setting #2 with positioner 141-0000-907. Crimp location should be centered between end of contact and x-hole. Crimp attachment to solid center conductor cables is not recommended.
5. Slide body assembly over contact, rear insulator and crimp insert. Crimp body using recommended crimp tool. Maintain forward pressure on cable while crimping. Body crimp die hex: .105 (2.67) hex.

Cable Group	Part No.	Crimp Hex
RG-178/U, 196	142-0402-011	.105 (2.67)
	142-0402-016	.105 (2.67)
	142-0302-011	.105 (2.67)
	142-0302-016	.105 (2.67)
	142-0302-431	.105 (2.67)
	142-0302-436	.105 (2.67)

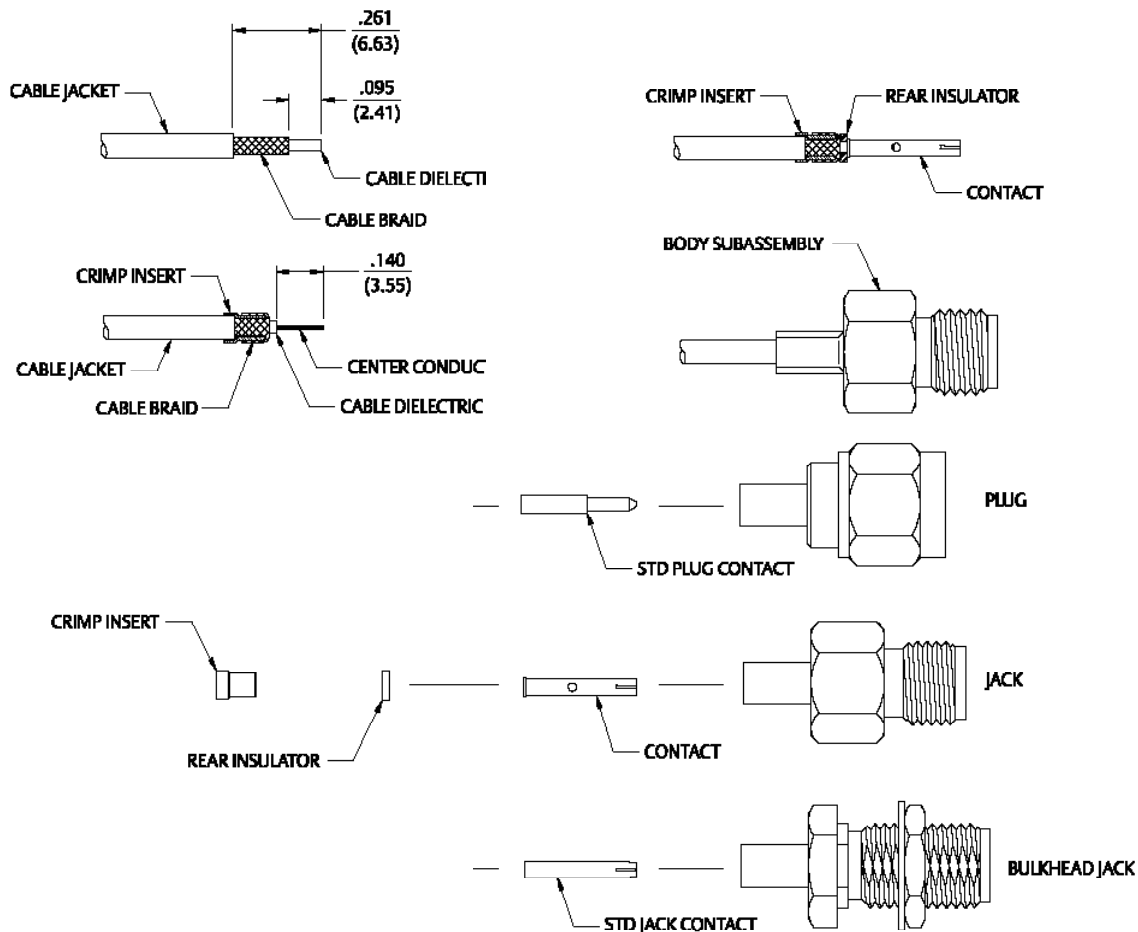

For more information, please contact customer service at (507) 833-8822 or (800) 247-8256 • cinch.com

Illustrations are shown in inches (millimeters).

SMA Type Straight Plugs, Straight Jacks, and Straight Bulkhead Jacks for Flexible Cable – Crimp or Solder Contacts

1. Identify connector parts. (3 piece parts – except bulkhead)
2. Strip cable to dimensions shown. Do not nick braid or center conductor. Tin center conductor if contact will be solder attached. Do not tin center conductor if contact is to be crimp attached. When stripping LMR-100 low loss cable, remove foil back to where cable jacket is stripped. A wire stripper of correct size is recommended for this step. Slide heat shrink (as applicable) and crimp sleeve onto jacket of cable.
3. Assemble contact onto cable as shown.
Solder Attachment: Solder contact to center conductor through solder hole using .020 (0.51) diameter solder. Use a minimum amount of solder for a good joint.
Crimp Attachment: Crimp contact to center conductor using Johnson Hand Tool 144-0000-910, setting #2, with positioner 141-0000-907. Crimp location should be centered between end of contact and X-hole. Crimp attachment to solid center conductor cables is not recommended.
4. Flare braid and slide body assembly over contact and under braid. Then seat body assembly firmly onto contact. The cable may have to be held in a clamping fixture. Arrange braid uniformly around crimp stem. Slide crimp sleeve forward and crimp using recommended crimp tool. Slide heat shrink forward and shrink (as applicable).

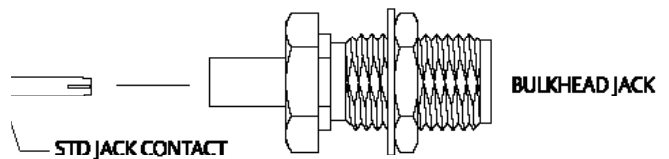
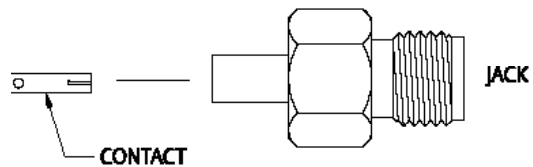
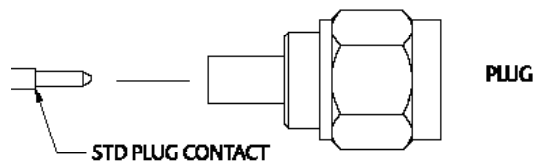
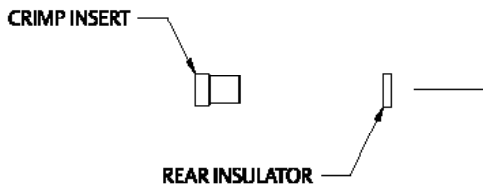
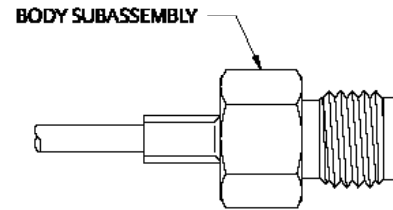
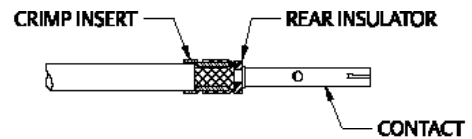
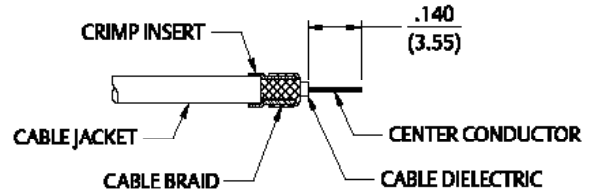
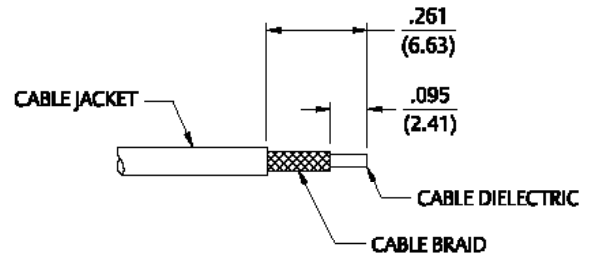

SMA Type Straight Plugs, Straight Jacks, and Straight Bulkhead Jacks for Flexible Cable – Crimp or Solder Contacts (cont'd from last page)

Cable Group	Part No.	"A"	"B"	Crimp Hex
RG-316/U, 161, 174, 188; LMR-100	141-0303-412	.128 (3.25)	.270 (6.86)	.105 (2.67)
RG-316 DS, 188 DS	141-0304-412	.151 (3.83)	.270 (6.86)	.128 (3.25)
RG-58/U, 141, 303	141-0307-412	.213 (5.41)	.270 (6.86)	.151 (3.83)
RG-55/U, 142, 223, 400	141-0308-412	.213 (5.41)	.270 (6.86)	.128 (3.25)
RG-316/U, 161, 174, 188; LMR-100	141-0403-012	.128 (3.25)	.270 (6.86)	.105 (2.67)
RG-316 DS, 188 DS	141-0404-012	.151 (3.83)	.270 (6.86)	.128 (3.25)
RG-58/U, 141, 303	141-0407-012	.213 (5.41)	.270 (6.86)	.151 (3.83)
RG-55/U, 142, 223, 400	141-0408-012	.213 (5.41)	.295 (7.49)	.213 (5.41)
RG-316/U, 161, 174, 188; LMR-100	142-0303-011/016 142-0303-411/416 142-9303-411	.215 (5.46) .215 (5.46)	.278 (7.06) .278 (7.06)	.128 (3.25) .128 (3.25)
RG-316 DS, 188 DS	142-0304-011/016 142-0304-411/416	.215 (5.46) .215 (5.46)	.278 (7.06) .278 (7.06)	.151 (3.83) .151 (3.83)
RG-58/U, 141, 303	142-0307-011/016 142-0307-411/416	.215 (5.46) .215 (5.46)	.278 (7.06) .278 (7.06)	.213 (5.41) .213 (5.41)
RG-55/U, 142, 223, 400	142-0308-011/016 142-0308-411/416	.215 (5.46) .215 (5.46)	.278 (7.06) .278 (7.06)	.213 (5.41) .213 (5.41)
RG-179/U, 187	142-0333-011/016 142-0333-411/416	.215 (5.46) .215 (5.46)	.278 (7.06) .278 (7.06)	.128 (3.25) .128 (3.25)
RG-316/U, 161, 174, 188; LMR-100	142-0403-011/016	.215 (5.46)	.278 (7.06)	.128 (3.25)
RG-316 DS, 188 DS	142-0404-011/016	.215 (5.46)	.278 (7.06)	.151 (3.83)
RG-58/U, 141, 303	142-0407-011/016	.215 (5.46)	.278 (7.06)	.213 (5.41)
RG-55/U, 142, 223, 400	142-0408-011/016	.215 (5.46)	.278 (7.06)	.213 (5.41)
RG-179/U, 187	142-0433-011/016	.215 (5.46)	.278 (7.06)	.128 (3.25)
RG-316/U, 161, 174, 188; LMR-100	142-1403-001/006	.280 (7.11)	.715 (18.16)	.128 (3.25)
RG-316 DS, 188 DS	142-1404-001/006	.280 (7.11)	.715 (18.16)	.151 (3.83)
RG-58/U, 141, 303	142-1407-001/006	.280 (7.11)	.715 (18.16)	.213 (5.41)
RG-55/U, 142, 223, 400	142-1408-001/006	.280 (7.11)	.715 (18.16)	.213 (5.41)
RG-316/U, 161, 174, 188; LMR-100	142-4303-401/406	.215 (5.46)	.278 (7.06)	.128 (3.25)
RG-316 DS, 188 DS	142-4304-401/406	.215 (5.46)	.278 (7.06)	.151 (3.83)
RG-58/U, 141, 303	142-4307-401/406	.215 (5.46)	.278 (7.06)	.213 (5.41)
RG-55/u, 142, 223, 400	142-4308-401/406	.215 (5.46)	.278 (7.06)	.213 (5.41)
RG-316/U, 161, 174, 188; LMR-100	142-4403-001/006	.215 (5.46)	.278 (7.06)	.128 (3.25)
RG-316 DS, 188 DS	142-4404-001/006	.215 (5.46)	.278 (7.06)	.151 (3.83)
RG-58/U, 141, 303	142-4407-001/006	.215 (5.46)	.278 (7.06)	.213 (5.41)
RG-55/U, 142, 223, 400	142-4408-001/006	.215 (5.46)	.278 (7.06)	.213 (5.41)
RG-316/U, 161, 174, 188; LMR-100	142-5303-401/406	.215 (5.46)	.278 (7.06)	.128 (3.25)
RG-316 DS, 188 DS	142-5304-401/406	.215 (5.46)	.278 (7.06)	.151 (3.83)
RG-58/U, 141, 303	142-5307-401/406	.215 (5.46)	.278 (7.06)	.213 (5.41)
RG-55/U, 142, 223, 400	142-5308-401/406	.215 (5.46)	.278 (7.06)	.213 (5.41)
RG-316/U, 161, 174, 188; LMR-100	142-5403-001/006	.215 (5.46)	.278 (7.06)	.128 (3.25)
RG-316 DS, 18 DS	142-5404-001/006	.215 (5.46)	.278 (7.06)	.151 (3.83)
RG-58/U, 141, 303	142-5407-001/006	.215 (5.46)	.278 (7.06)	.213 (5.41)
RG-55/U, 142, 223, 400	142-5408-001/006	.215 (5.46)	.278 (7.06)	.213 (5.41)
RG-316/U, 161, 174, 188; LMR-100	142-9403-011	.215 (5.46)	.278 (7.06)	.128 (3.25)
RG-316 DS, 188 DS	142-9404-011	.215 (5.46)	.278 (7.06)	.151 (3.83)
RG-58/U, 141, 303	142-9407-011	.215 (5.46)	.278 (7.06)	.213 (5.41)

For more information, please contact customer service at (507) 833-8822 or (800) 247-8256 • cinch.com

Illustrations are shown in inches (millimeters).

Straight SMA Low Loss Diameter .195, .200 and .240 Straight Type Plugs

1. Identify connector parts. (3 piece parts – except bulkhead)
2. Strip cable to dimensions shown. Do not nick braid, foil or center conductor. Cut foil flush with dielectric, do not remove foil. Make sure that dielectric is clean and free from all particles. Tin center conductor, keeping solder amount to a minimum. Slide crimp sleeve onto jacket of cable.
3. Assemble contact onto cable as shown. Position contact such that a gap of no more than .020 (0.51) is kept between dielectric and contact. Solder contact to center conductor through solder hole using .020 (0.51) Diameter solder. Use a minimum amount of solder for a good joint. Do not allow contact to move into dielectric during soldering process.
4. Flare braid and slide body assembly over contact, foil and dielectric, then under braid. Seat body assembly firmly onto contact. Arrange braid uniformly around crimp stem. Slide crimp sleeve forward and crimp using Johnson hand crimp tool 141-0000-913 and recommended crimp die hex.

Cable Group	Part No.	Crimp Hex
LMR-195	142-0307-411	.213 (5.41)
	142-0307-416	.213 (5.41)
LMR-240	142-0335-401	.255 (6.48)
	142-0335-406	.255 (6.48)
LMR-200	142-0339-401	.213 (5.41)
	142-0339-406	.213 (5.41)
LMR-195	142-0407-011	.213 (5.41)
	142-0407-016	.213 (5.41)
LMR-240	142-0435-001	.255 (6.48)
	142-0435-006	.255 (6.48)
LMR-200	142-0439-001	.213 (5.41)
	142-0439-006	.213 (5.41)
LMR-240	142-4435-001	.255 (6.48)
	142-4435-006	.255 (6.48)
LMR-200	142-4439-001	.213 (5.41)
	142-4439-006	.213 (5.41)
LMR-195	142-4407-001	.213 (5.41)
	142-4407-006	.213 (5.41)
LMR-240	142-5435-001	.255 (6.48)
	142-5435-006	.255 (6.48)
LMR-200	142-5439-001	.213 (5.41)
	142-5439-006	.213 (5.41)
LMR-195	142-5407-001	.213 (5.41)
	142-5407-006	.213 (5.41)

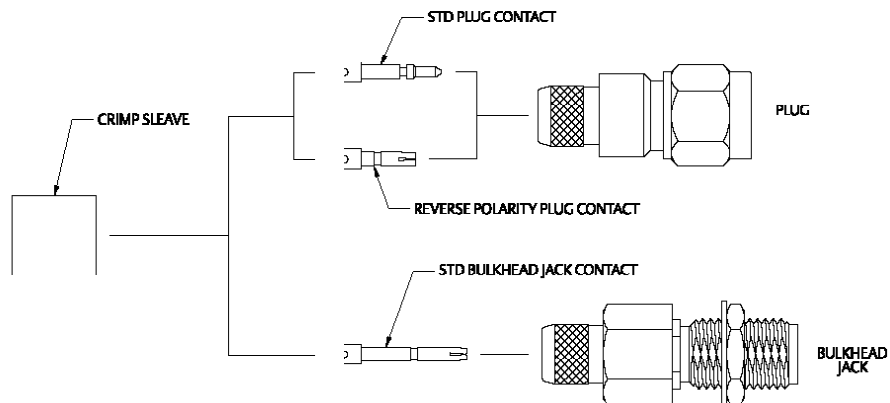
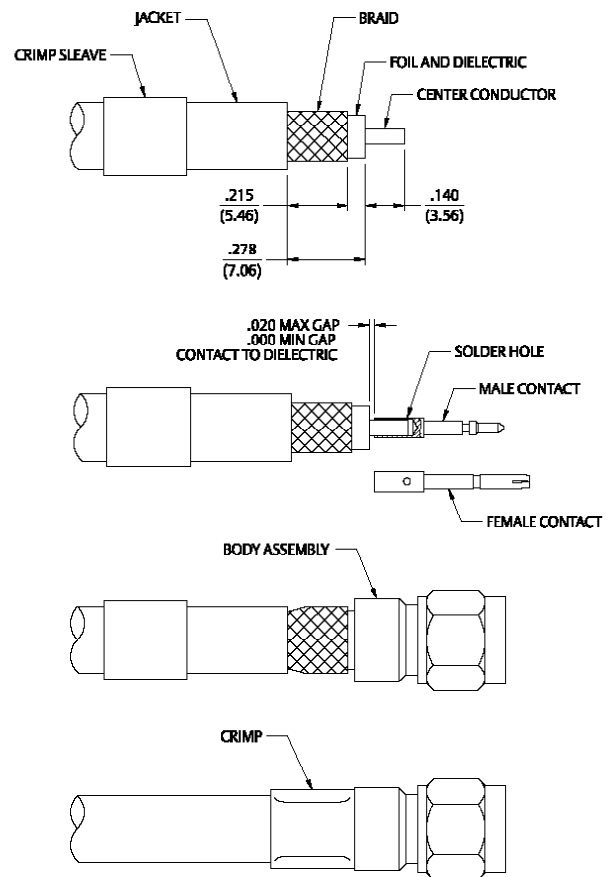

SMA Straight Solder Type for Semi-Rigid Cables

1. Identify the connector (plug or jack) and tools.
2. Strip the cable jacket and dielectric to dimension shown. Do not nick the center conductor.
3. Bevel the entire diameter on the end of the cable center conductor until the point resembles the appropriate dimensional profile. This operation can be accomplished effectively by using the recommended center conductor pointing tool as described in step 4.
4. Insert the stripped cable into the bushing of the appropriate pointing tool until the center conductor just touches the blade. While maintaining light pressure on the center conductor against the blade, turn the tool in a counter-clockwise fashion as viewed from the bushing end of the tool. Continue cutting the center conductor point until the cable jacket bottoms out inside the bushing.
5. Attach the appropriate soldering mating fixture to the connector and tighten to a maximum of 8 inch pounds of torque.
6. Clean all debris from the prepared cable and insert the cable into the connector, making sure that the cable jacket bottoms out against the internal shoulder of the connector body.
7. Insert the stop screw into the mating fixture. Clamp the cable and fixtured connector assembly securely in the soldering vise. Solder the connector body to the cable as shown, while insuring the cable dielectric expansion does not move the assembly. Allow the assembly to cool before removing the connector from the fixture.

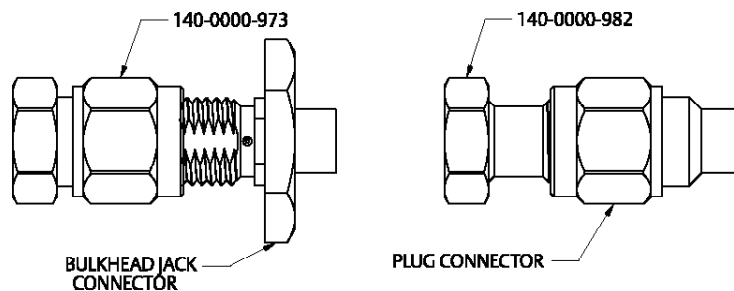
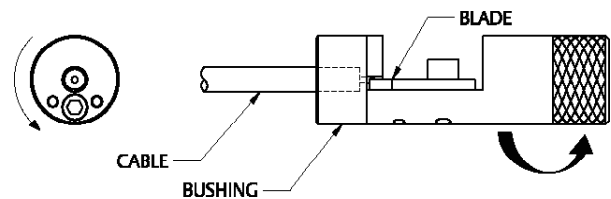
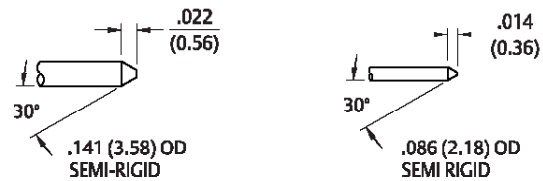
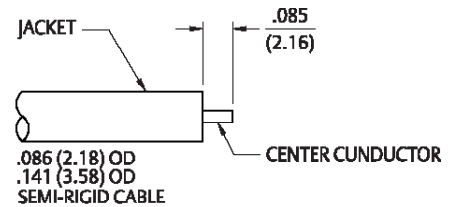
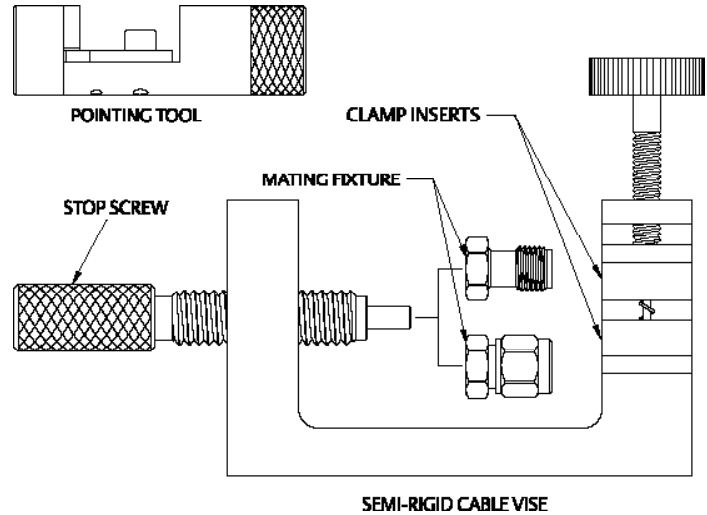

For more information, please contact customer service at (507) 833-8822 or (800) 247-8256 • cinch.com

Illustrations are shown in inches (millimeters).

SMA Straight Solder Type for Semi-Rigid Cables (cont'd from last page)

Cable Group	Part No.
RG-405/U (.086 Semi-Rigid)	141-0593-421 141-0693-062
RG-402/U (.141 Semi-Rigid)	141-0594-421 141-0694-062

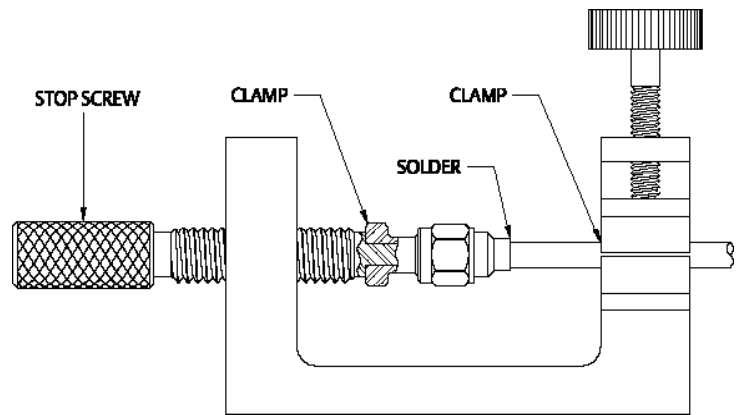
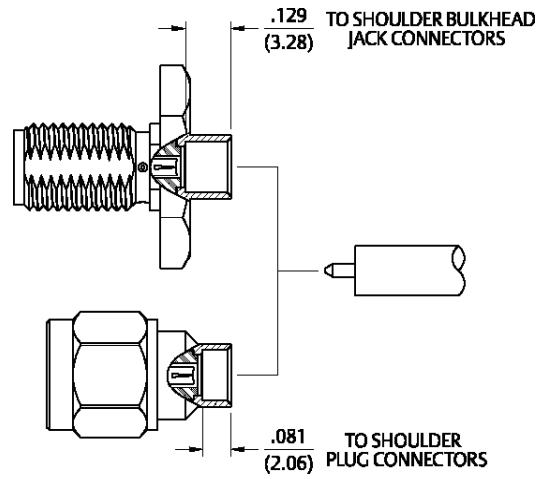

SMA Crimp Type Right Angle Plugs for Flexible Cable

1. Identify connector parts. (3 piece parts)
2. Strip cable to dimensions shown. Do not nick braid or center conductor. When stripping LMR-100 low loss cable, remove foil back to where cable jacket is stripped. A wire stripper of correct size is recommended for this step. Twist stranded center conductor into tight bundle and tin (optional). Slide crimp sleeve onto cable as shown.
3. Flare braid and slide cable into body making certain that the cable insulation bottoms on center contact. Solder center conductor to contact through the rear access port. Use a minimum amount of solder for a full fillet joint. .020 (0.51) diameter solder is recommended.
4. Arrange braid uniformly around crimp stem. Slide crimp sleeve over braid and crimp securely using recommended crimp tool. Place expansion cap in access port and seat with .187 (4.75) diameter flat punch. Shrink heat shrink tubing over crimp sleeve if applicable.

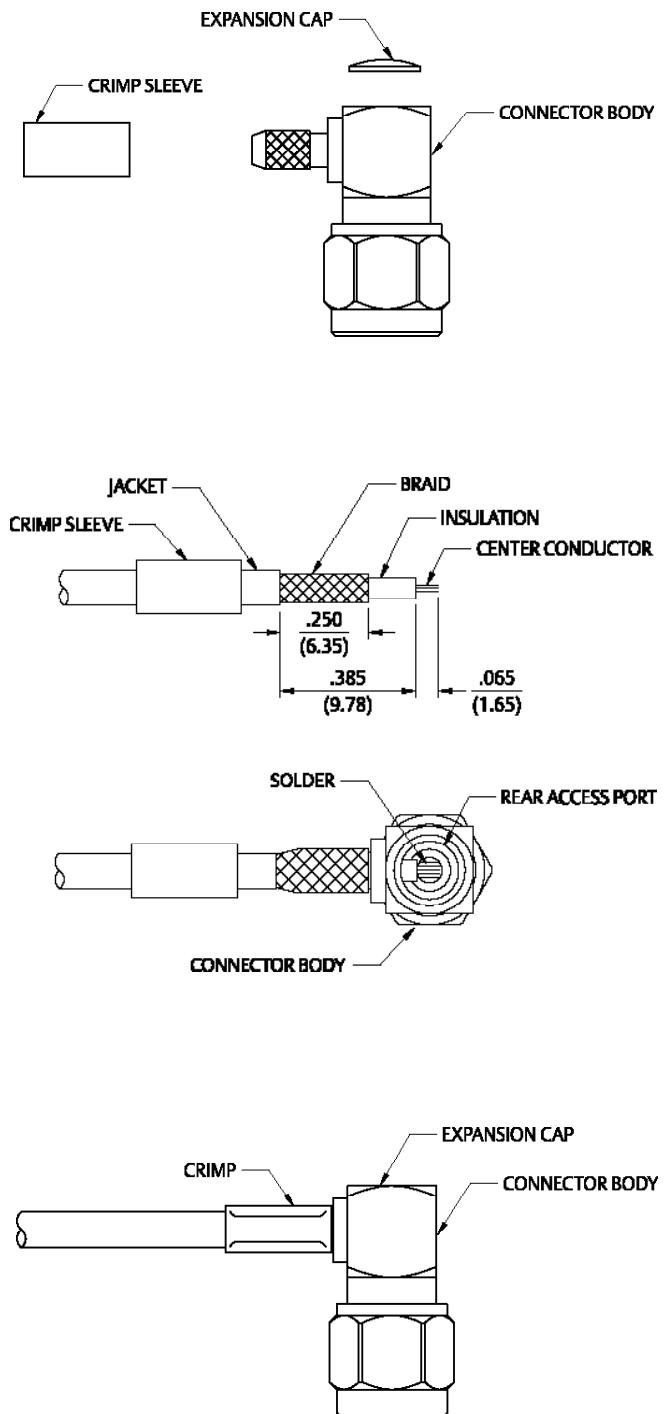

For more information, please contact customer service at (507) 833-8822 or (800) 247-8256 • cinch.com

Illustrations are shown in inches (millimeters).

SMA Crimp Type Right Angle Plugs for Flexible Cable (cont'd from last page)

Cable Group	Part No.	Crimp Hex
RG-316/U, 161, 174, 188; LMR-100	141-0403-102	.128 (3.25)
RG-316 DS, 188 DS	141-0404-112	.151 (3.83)
RG-58/U, 141, 303	141-0407-102	.213 (5.41)
RG-55/U, 142, 223, 400	141-0408-102	.213 (5.41)
RG-178/U, 196	142-0402-101 142-0402-106	.105 (2.67) .105 (2.67)
RG-316/U, 161, 174, 188; LMR-100	142-0403-101 142-0403-106	.128 (3.25) .128 (3.25)
RG-316 DS, 188 DS	142-0404-101 142-0404-106	.151 (3.83) .151 (3.83)
RG-58/U, 141, 303	142-0407-101 142-0407-106	.213 (5.41) .213 (5.41)
RG-55/U, 142, 223, 400	142-0408-101 142-0408-106	.213 (5.41) .213 (5.41)
RG-179/U, 187	142-0433-101 142-0433-106	.128 (3.25) .128 (3.25)
RG-316/U, 161, 174, 188; LMR-100	142-4403-101 142-4403-106	.128 (3.25) .128 (3.25)
RG-316 DS, 188 DS	142-4404-101 142-4404-106	.151 (3.83) .151 (3.83)
RG-58/U, 141, 303	142-4407-101 142-4407-106	.213 (5.41) .213 (5.41)
RG-55/U, 142, 223, 400	142-4408-101 142-4408-106	.213 (5.41) .213 (5.41)
RG-316/U, 161, 174, 188; LMR-100	142-5403-101 142-5403-106	.128 (3.25) .128 (3.25)
RG-316 DS, 188 DS	142-5404-101 142-5404-106	.151 (3.83) .151 (3.83)
RG-58/U, 141, 303	142-5407-101 142-5407-106	.213 (5.41) .213 (5.41)
RG-55/U, 142, 223, 400	142-5408-101 142-5408-106	.213 (5.41) .213 (5.41)
RG-316/U, 188, 174	142-9403-101	.128 (3.25)
RG-316 DS, 188 DS	142-9404-101	.151 (3.83)
RG-58/U, 141	142-9407-101	.213 (5.41)

SMA Crimp Type Straight Plugs, Straight Jacks, and Straight Bulkhead Jacks for Flexible Cable

1. Identify connector parts. (6 piece parts – except bulkhead)
2. Strip cable to dimensions shown. Do not nick braid or center conductor. A wire stripper of correct size is recommended for this step. Twist stranded center conductor into tight bundle and tin (optional). Slide crimp sleeve, nut and heat shrink tubing (as applicable) onto cable as shown.
3. Flare braid and slide cable into crimp stem. Place rear insulator and center contact over center conductor and position as shown for different cable sizes. Solder center conductor to contact through the solder hole. Solder must not be allowed to gather and run on outside of contact. Use a minimum amount of solder for a good joint. .020 (0.51) diameter solder is recommended.
4. Arrange braid uniformly around crimp stem. Slide crimp sleeve over braid and crimp securely using recommended crimp tool. Slide center contact assembly into connector body. Thread coupling nut onto body and tighten to 10 in.-lb. torque. Slide heat shrink forward and shrink (as applicable)

Cable Group	Part No.	Crimp Hex
RG-178/U, 196	142-0302-401 142-0302-406	.105 (2.67) .105 (2.67)
RG-316/U, 161, 174, 188	142-0303-401 142-0303-406	.128 (3.25) .128 (3.25)
RG-316 DS, 188 DS	142-0304-401 142-0304-406	.151 (3.83) .151 (3.83)
RG-58/U, 141, 303	142-0307-401 142-0307-406	.213 (5.41) .213 (5.41)
RG-55/U, 142, 223, 400	142-0308-401 142-0308-406	.213 (5.41) .213 (5.41)
RG-316/U, 161, 174, 188	142-0403-001 142-0403-006	.128 (3.25) .128 (3.25)

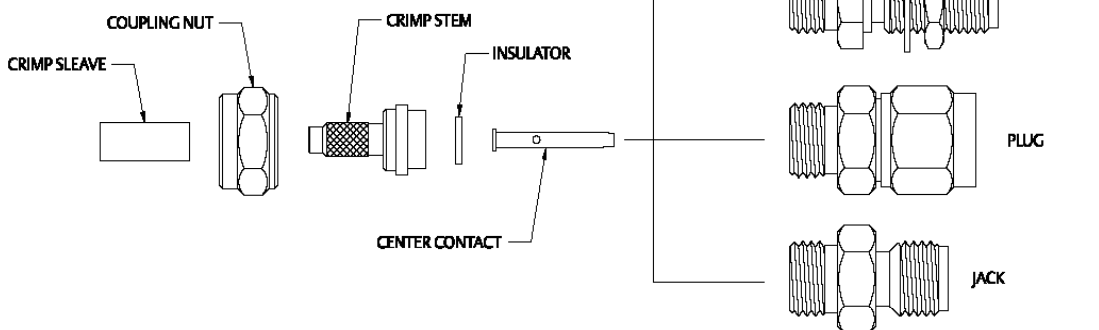
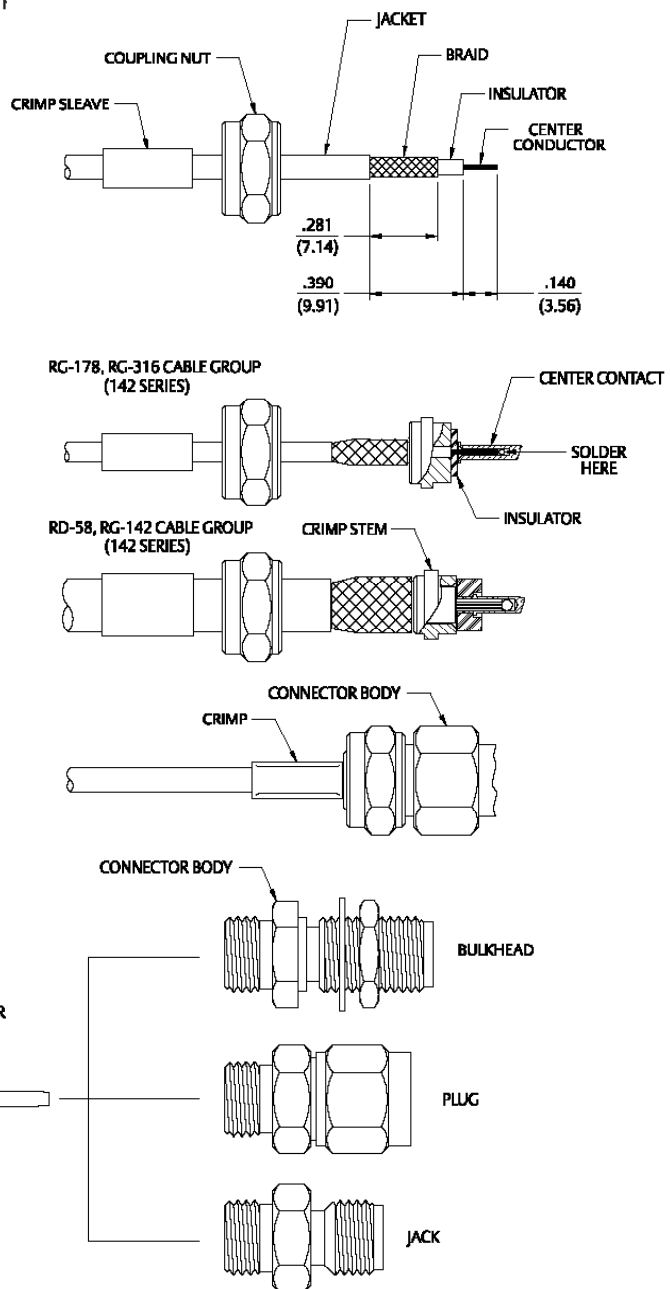

For more information, please contact customer service at (507) 833-8822 or (800) 247-8256 • cinch.com

Illustrations are shown in inches (millimeters).

SMA High Frequency End Launch Connectors PC Mounting Instructions

High frequency end launch performance is dependent upon proper mounting. The following factors must be controlled for optimum performance:

- The connector should fit tightly against the circuit board edge, avoid gaps.
- The center contact pin must lie parallel and flat against the circuit board, avoid gaps.
- The contact pin should be centered on the circuit board signal trace.
- Use a minimal amount of solder between the contact pin and signal trace. Do not allow excess solder to build up or flow down the trace.
- Clean all excess flux and other residue from the launch area, especially between the trace and ground.

The basic steps required to mount the end launch connector to the circuit board are as follows:

- Fixture 140-0000-973 should be used as an aid during manual soldering. The fixture protects the connector from damage during clamping and also maintains the proper location of the connector's insulator and contact. To use the fixture, thread the coupling nut on the mating end of the connector and hand tighten. This mounting assembly can now be held in a vice or similar clamping device, as shown in Figure 1.
- Position connector on the circuit board, making sure the contact pin is aligned with the center of the signal trace as shown in Figure 2. Make sure that the connector legs and contact pin are held flush against the top of the circuit board, keeping the axis of the connector parallel to the plane of the circuit board, as shown in Figure 3.
- A small amount of Teflon® insulation projects from rear mating plane of the connector, which acts as a seal when soldering the center conductor pin to the trace. Clamp the connector tightly against the edge of the board. This action compresses the insulator seal against the board edge. This effectively creates a barrier between the inner and outer conductors, preventing the bridging of solder.
- While ensuring the connector is held in the correct position, solder the ground legs and/or ground posts to the top and bottom of the board prior to bonding the center pin to the trace.
- Once the connector body is properly grounded to the board, the center contact pin can be bonded to the trace by using a minimal amount of solder as shown in Figure 4. It is important that solder flows along the length of the exposed pin, creating a good electrical and mechanical connection. Remove any excess solder that is not required for a solid joint.
- Clean all flux and other residues from the trace area between the signal side ground legs, as any flux present between the signal trace and ground will affect performance. The completed mounting assembly should look similar to the one shown in Figure 5.

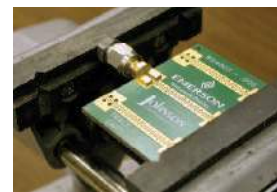

Figure 1

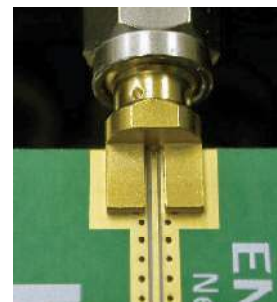

Figure 2



Figure 3



Figure 4

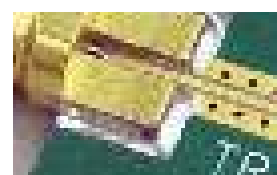

Figure 5

The **End Launch** connector is attached to the circuit board by inserting the board edge between the legs and soldering the legs and center conductor to the pads on the board. For optimum high frequency performance, the connector to circuit board transition must be adjusted for low VSWR. To compensate for the transition from coax to microstrip, trace widths "A" and "B" must be adjusted based on circuit board thickness. When properly adjusted, this technique yields a low VSWR over a wide bandwidth.



The tabulated dimensions "A", "B", "C", "D", and "E" were determined experimentally to achieve low VSWR (typically less than 1.5 up to 18 GHz). The circuit board uses connectors for these tests that are double-sided FR4 with 1 oz. copper on both sides. The copper was left on the bottom of the board to create a ground plane for the 50 Ohm microstrip structure. While not all inclusive, these dimensions are given as reference information for selected SMA End Launch connectors. Further adjustments may be necessary depending upon the application. All dimensions are in inches (millimeters).

Part No.	Base Width	Board Thickness	"A"	"B"	"C"	"D"	"E"
142-0791-801	.375	.062 (1.57)	.073	.073	.250	.440	.200
142-0791-811	.375	.042 (1.07)	.103	.103	.250	.440	.200
142-0791-821	.375	.062 (1.57)	.083	.083	.250	.440	.200
142-1701-821	.375	.062 (1.57)	See Figure 2 below for attachment dimensions				
142-1701-831	.375	.059 (1.50)	See Figure 2 below for attachment dimensions				

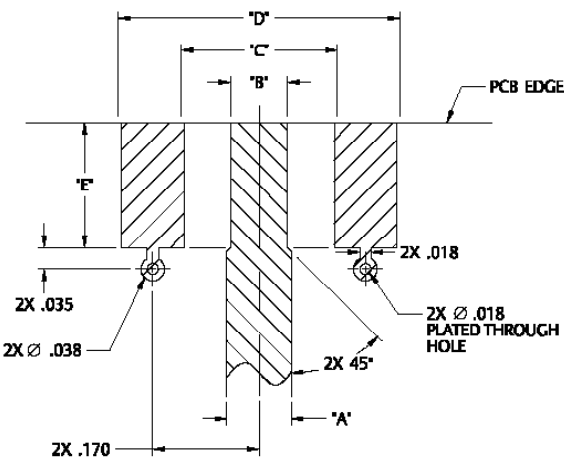

Figure 1

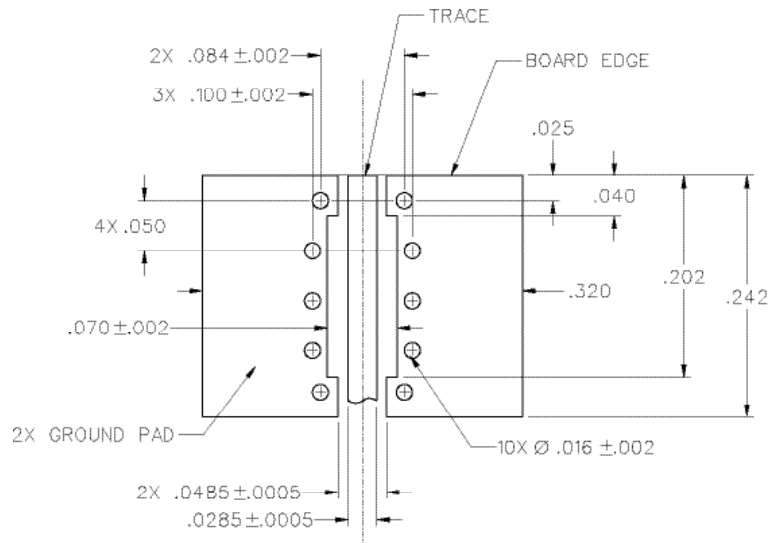

Figure 2

For more information, please contact customer service at (507) 833-8822 or (800) 247-8256 • cinch.com

Illustrations are shown in inches (millimeters).

Reference dimensions for 50 Ohm grounded coplanar waveguide using Rogers Corporation RO4003C™ high frequency substrate laminate *

Holes	GCPW 50Ω Impedance Reference Dimensions *				Mounting and Via		
Part No.	Substrate Thickness	Conductor Thickness	Trace Width "A"	Ground Gaps "B"	Fig	"C"	"D"
142-0761-801	.0080 (0.203)	.0014 (0.036)	.0155 (0.394)	.0100 (0.254)	1	.066 (1.68)	.096 (2.44)
142-0761-811	.0080 (0.203)	.0014 (0.036)	.0155 (0.394)	.0100 (0.254)	1	.066 (1.68)	.096 (2.44)
142-0761-821	.0160 (0.406)	.0014 (0.036)	.0285 (0.724)	.0100 (0.254)	1	.084 (2.13)	.113 (2.87)
142-0761-831	.0160 (0.406)	.0014 (0.036)	.0285 (0.724)	.0100 (0.254)	1	.084 (2.13)	.113 (2.87)
142-0761-841	.0080 (0.203)	.0014 (0.036)	.0155 (0.394)	.0100 (0.254)	2	.066 (1.68)	
142-0761-851	.0080 (0.203)	.0014 (0.036)	.0155 (0.394)	.0100 (0.254)	2	.066 (1.68)	
142-0761-861	.0160 (0.406)	.0014 (0.036)	.0285 (0.724)	.0100 (0.254)	2	.084 (2.13)	
142-0761-871	.0160 (0.406)	.0014 (0.036)	.0285 (0.724)	.0100 (0.254)	2	.084 (2.13)	
142-0761-881	.0080 (0.203)	.0014 (0.036)	.0155 (0.394)	.0100 (0.254)	1	.066 (1.68)	.096 (2.44)
142-0761-891	.0080 (0.203)	.0014 (0.036)	.0155 (0.394)	.0100 (0.254)	2	.066 (1.68)	
142-0771-821	.0160 (0.406)	.0014 (0.036)	.0285 (0.724)	.0100 (0.254)	1	.084 (2.13)	.113 (2.87)
142-0771-831	.0160 (0.406)	.0014 (0.036)	.0285 (0.724)	.0100 (0.254)	2	.084 (2.13)	

* These calculated dimensions assume a quasi-static mode of propagation, but dispersion does exist for coplanar waveguide. The characteristic impedance and effective dielectric constant may increase slightly for X-band and higher frequencies, unless very small ground to ground gap spacing is used.

It is assumed the conductors have rectangular cross-sections. The etching process used in circuit board fabrication actually produces trapezoidal shapes. Therefore, the GCPW impedance may increase somewhere between that of a perfect rectangular conductor and a theoretical zero thickness conductor.

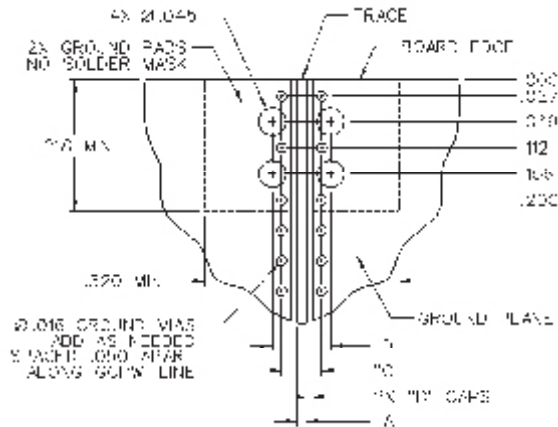

Figure 1

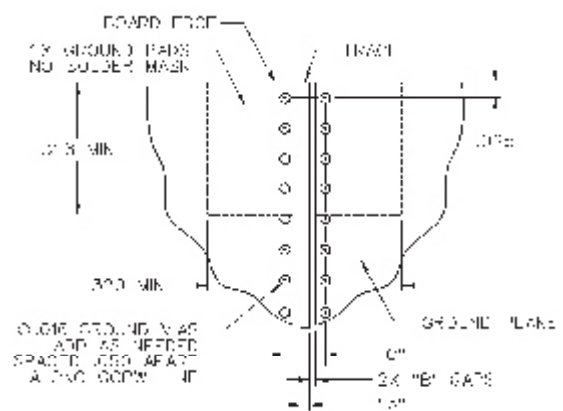
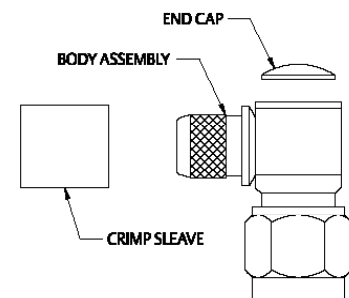

Figure 2

Right Angle SMA Low Loss Diameter .195, .200 and .240

1. Identify connector parts. (3 piece parts)
2. Strip cable to dimensions shown. Do not nick braid, foil or center conductor. Cut foil flush with dielectric, do not remove foil. Make sure that dielectric is clean and free from all particles. Tin center conductor, keeping solder amount to a minimum. Slide crimp sleeve onto jacket of cable.
3. Flare braid and slide body assembly over foil and dielectric, then under braid. Make sure cable center conductor is contained within connector contact, but do not allow foil and dielectric to enter body access port. Solder center conductor to contact through the rear access port. Use a minimum amount of solder for a full fillet joint. .020 (0.51) Diameter solder is recommended.
4. Arrange braid uniformly around crimp stem. Slide crimp sleeve forward and crimp using Johnson hand crimp tool 141-0000-913 and recommended crimp die hex. Place expansion cap in access port and seat with recommended Diameter flat punch.

Low Loss Diameter	"A"	Crimp Die Hex	Flat Punch Diameter
0.195	.110 (2.79)	.213 (5.41) hex	.187 (4.75)
0.200	.110 (2.79)	.213 (5.41) hex	.187 (4.75)
0.240	.135 (3.43)	.255 (6.48) hex	.242 (6.15)



Cable Group	Part No.	Crimp Hex
LMR-195	142-0407-101	.213 (5.41)
	142-0407-106	.213 (5.41)
LMR-200	142-4439-101	.213 (5.41)
	142-4439-106	.213 (5.41)
LMR-240	142-0435-101	.255 (6.48)
	142-0435-106	.255 (6.48)
LMR-195	142-5407-101	.213 (5.41)
	142-5407-106	.213 (5.41)
LMR-200	142-0439-101	.213 (5.41)
	142-0439-106	.213 (5.41)
LMR-240	142-5435-101	.255 (6.48)
	142-5435-106	.255 (6.48)
LMR-195	142-4407-101	.213 (5.41)
	142-4407-106	.213 (5.41)
LMR-200	142-5439-101	.213 (5.41)
	142-5439-106	.213 (5.41)
LMR-240	142-4435-101	.255 (6.48)
	142-4435-106	.255 (6.48)

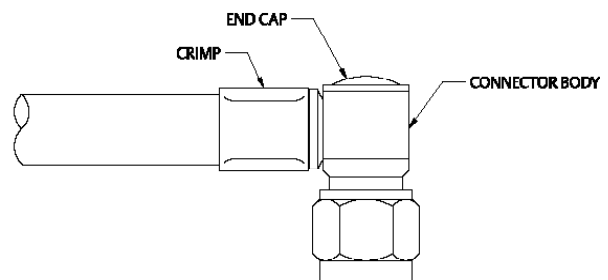
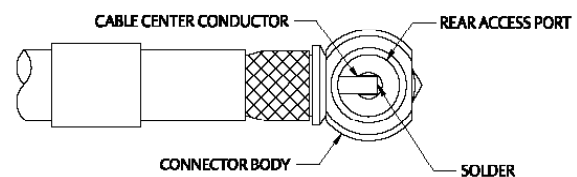
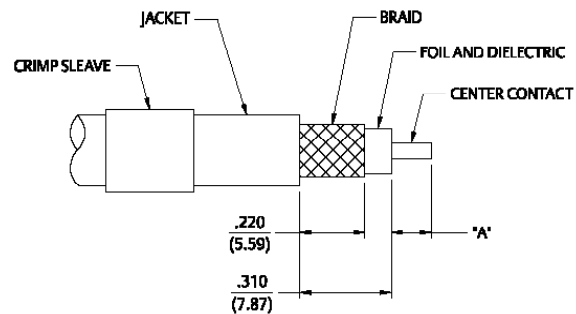

For more information, please contact customer service at (507) 833-8822 or (800) 247-8256 • cinch.com

Illustrations are shown in inches (millimeters).

SMA Clamp Type Straight Plugs, Straight Jacks, and Straight Bulkhead Jacks for Flexible Cable

1. Identify connector parts. (6 piece parts – except bulkhead)
2. Strip cable to dimensions shown. Do not nick braid or center conductor. A wire stripper of correct size is recommended for this step. Twist stranded center conductor into tight bundle and tin (optional). Slide clamp nut and clamp cone onto cable as shown. Clamp cone must be oriented as shown for each size of cable. The RG-58/142 clamp cone slides over braid and against jacket.
3. Flare braid and slide cable into clamp stem. Place rear insulator and center contact over center conductor and position as shown for different cable sizes. Solder center conductor to contact through the solder hole. Solder must not be allowed to gather and run on outside of contact. Use a minimum amount of solder for a good joint. .020 (0.51) diameter solder is recommended.
4. Arrange braid uniformly around clamp stem. Slide center contact assembly into body. Slide clamp nut against clamp cone and braid and tighten to 10 in.-lb. torque.

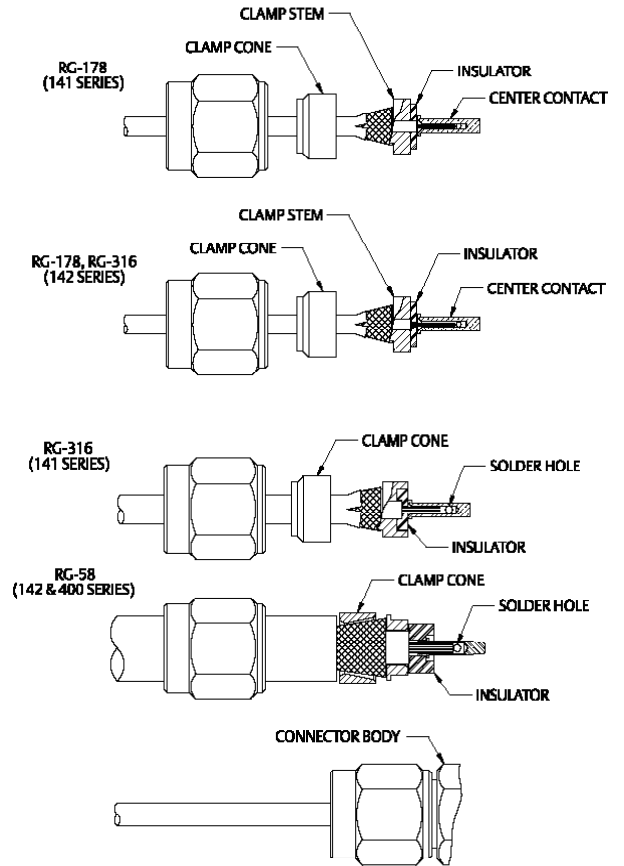

Cable Group	Part No.	"A"	"B"	"C"
RG-178/U, 196	142-0202-011/016	.133 (3.38)	.053 (1.35)	.085 (2.16)
RG-161/U, 174,188, 316	142-0203-011/016	.133 (3.38)	.053 (1.35)	.085 (2.16)
RG-58/U, 141, 303	142-0207-011/016	.225 (5.72)	.145 (3.68)	NONE
RG-142, 223, 55, 400	142-0207-011/016	.285 (7.24)	.165 (4.19)	NONE
RG-178/U, 196	142-0102-401/406	.133 (3.38)	.053 (1.35)	.085 (2.16)
RG-161/U, 174,188, 316	142-0103-401/406	.133 (3.38)	.053 (1.35)	.085 (2.16)
RG-58/U, 141, 303	142-0107-401/406	.225 (5.72)	.145 (3.68)	NONE
RG-142, 223, 55, 400	142-0107-401/406	.285 (7.24)	.165 (4.19)	NONE

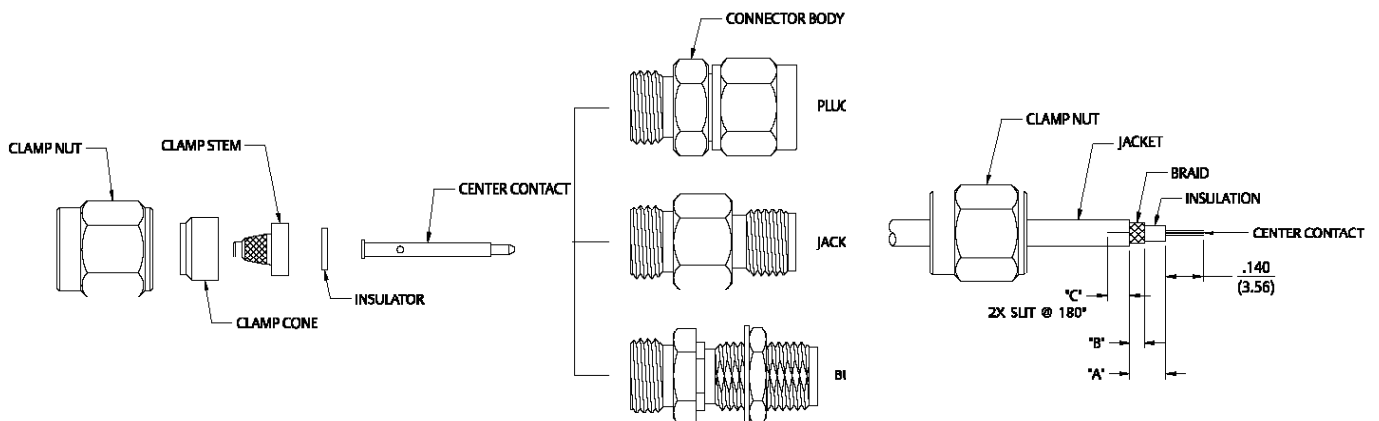

SMA Clamp Type Right Angle Plugs for Flexible Cable

1. Identify connector parts. (4 piece parts)
2. Strip cable to dimensions shown. Do not nick braid or center conductor. A wire stripper of correct size is recommended for this step. Twist stranded center conductor into tight bundle and tin (optional). Slide clamp nut and clamp cone onto cable as shown. Clamp cone must be oriented as shown for each size of cable. The RG-58/142 clamp cone slides over braid and against jacket.
3. Flare braid and slide cable into body making certain that the cable insulation bottoms on center contact. Stepped down diameter of stem must slide under braid and jacket. Arrange braid uniformly around crimp stem. Slide clamp nut against clamp cone and braid and tighten to 10 in.-lb. torque.
4. Solder center conductor to contact through the rear access port. Use a minimum amount of solder for a full fillet joint. .020 (0.51) diameter solder is recommended. Place expansion cap in access port and seat with .187 (4.75) diameter flat punch.

Cable Group	Part No.	"A"	"B"	"C"
RG-178/U, 196	142-0202-101	.280 (7.11)	.053 (1.35)	.085 (2.16)
	142-0202-106	.280 (7.11)	.053 (1.35)	.085 (2.16)
RG-316/U, 161, 174, 188	142-0203-101	.280 (7.11)	.053 (1.35)	.085 (2.16)
	142-0203-106	.280 (7.11)	.053 (1.35)	.085 (2.16)
RG-58/U 141, 303	142-0207-101	.395 (10.03)	.160 (4.06)	NONE
	142-0207-106	.395 (10.03)	.160 (4.06)	NONE
RG-55/U, 142, 233, 400	142-0207-101	.420 (10.67)	.180 (4.57)	NONE
	142-0207-106	.420 (10.67)	.180 (4.57)	NONE

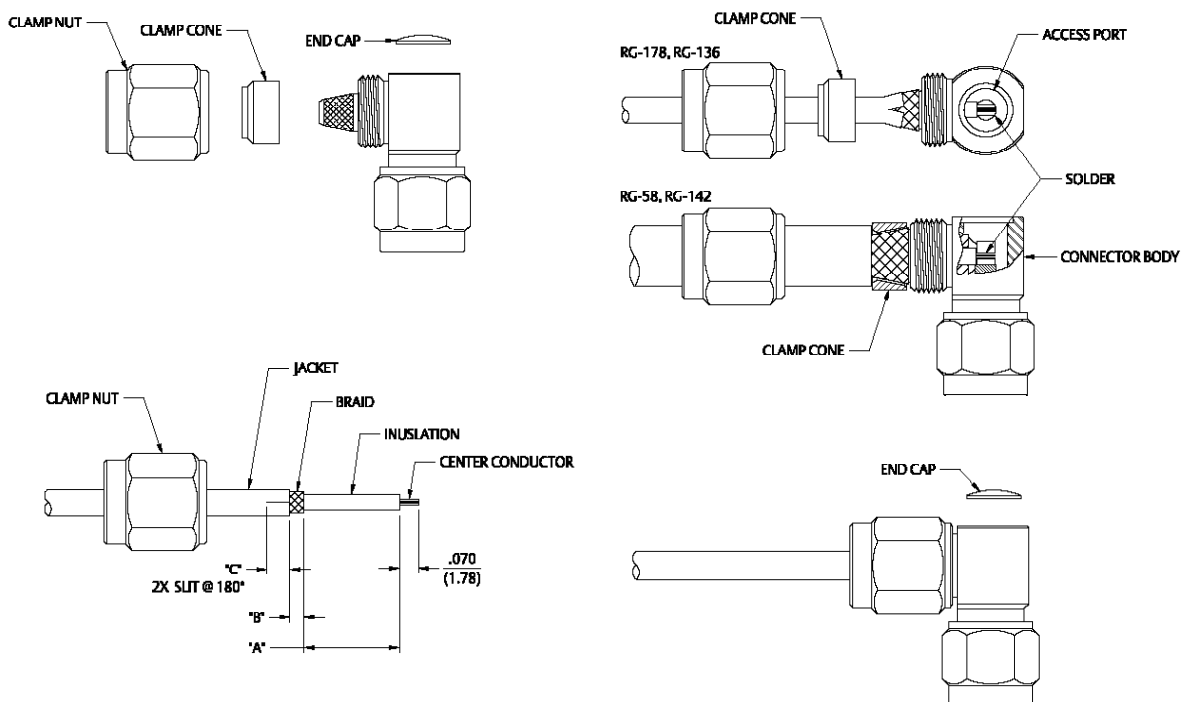

For more information, please contact customer service at (507) 833-8822 or (800) 247-8256 • cinch.com

Illustrations are shown in inches (millimeters).

SMB 3-Piece Straight Plugs

- Identify connector parts. (3 piece parts): Crimp sleeve, body assembly and contact
- Strip cable to dimensions shown. Do not nick braid or center conductor. Tin center conductor if contact will be solder attached. Do not tin center conductor if contact is to be crimp attached. Slide heat shrink (as applicable) and crimp sleeve onto jacket of cable.
- Assemble contact onto cable as shown.

Solder Attachment: Solder contact to center conductor through solder hole using .015 (0.38) diameter solder. Use a minimum amount of solder for a good joint.

Crimp Attachment: A miniature 8 indent crimp tool 140-0000-970 is recommended. Crimp location should be centered between end of contact and X-hole using positioner 140-0000-971. Crimp attachment to solid center conductor cables is not recommended.
- Flare braid and slide body assembly over contact and under braid. Then seat body assembly firmly onto contact. The cable may have to be held in a clamping fixture. Arrange braid uniformly around crimp stem. Slide crimp sleeve forward and crimp using recommended crimp tool. Slide heat shrink forward and shrink (as applicable).

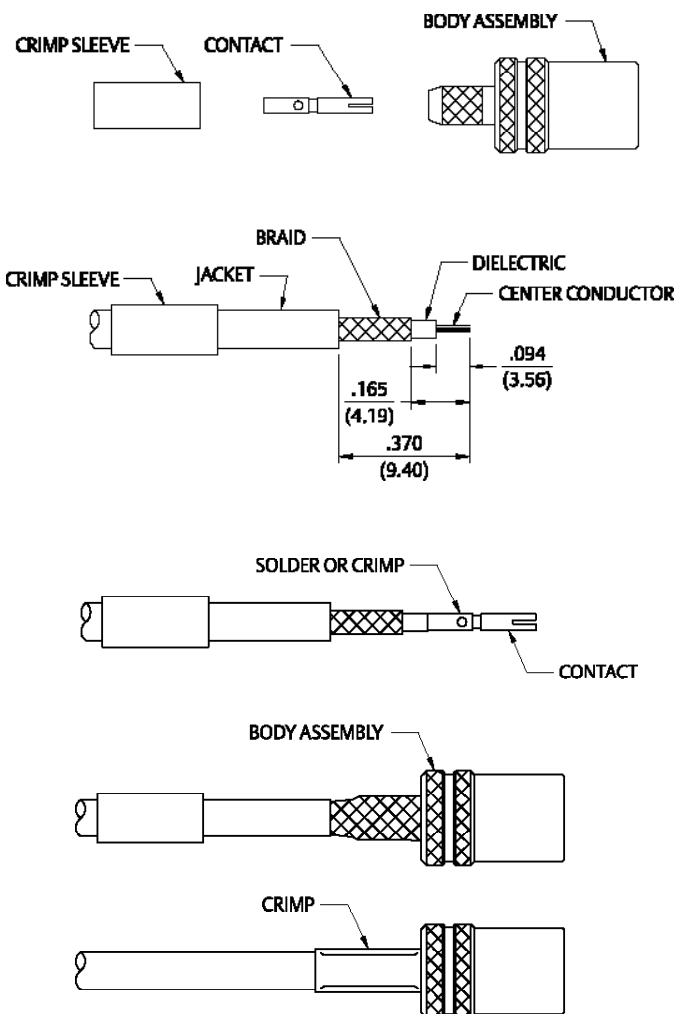

Cable Group	Part No.	Crimp Hex
RG-316/U, 161, 174, 179, 187, 188	131-3403-021/026	.128 (3.25)
RG-316 DS, 188 DS, 179 DS	131-3404-021/026	.151 (3.83)
RG-58/U, 141, 303	131-3407-011/016	.213 (5.41)
RG-179/U, 187	131-8433-001/006	.128 (3.25)
RG-179 DS, 187 DS	131-8434-001/006	.151 (3.83)
Belden 735A	131-8445-011/016	.178 (4.52)
RG-316/U, 188, 174, 179, 187	131-9403-021	.128 (3.25)
RG-316 DS, 188 DS, 179 DS, 187 DS	131-9404-021	.151 (3.83)

SMB/SMC Solder Type Straight Plugs and Jacks for Semi-Rigid Cable

1. Identify connector parts. (2 piece parts – except bulkhead)
2. Strip cable to dimensions shown. Do not nick center conductor. Slide cover sleeve onto cable as shown.
3. Insert cable into body making certain that the cable insulation bottoms on center contact. Solder center conductor to contact through the side access ports and hole in center contact. Use a minimum amount of solder for a good joint. .020 (0.51) diameter solder is recommended.
4. Slide cover sleeve over access ports and solder body to cable and cover sleeve to body. Use a minimum amount of heat to minimize cable insulation movement.

Cable Group	Part No.	"A"
RG-405/U (.086 Semi-Rigid)	131-3593-401/406	.025 (0.64)
	131-3693-001/016	.025 (0.64)
RG-402/U (.141 Semi-Rigid)	131-3694-401/406	.050 (1.27)
RG-405/U (.086 Semi-Rigid)	131-6593-401/406	.025 (0.64)

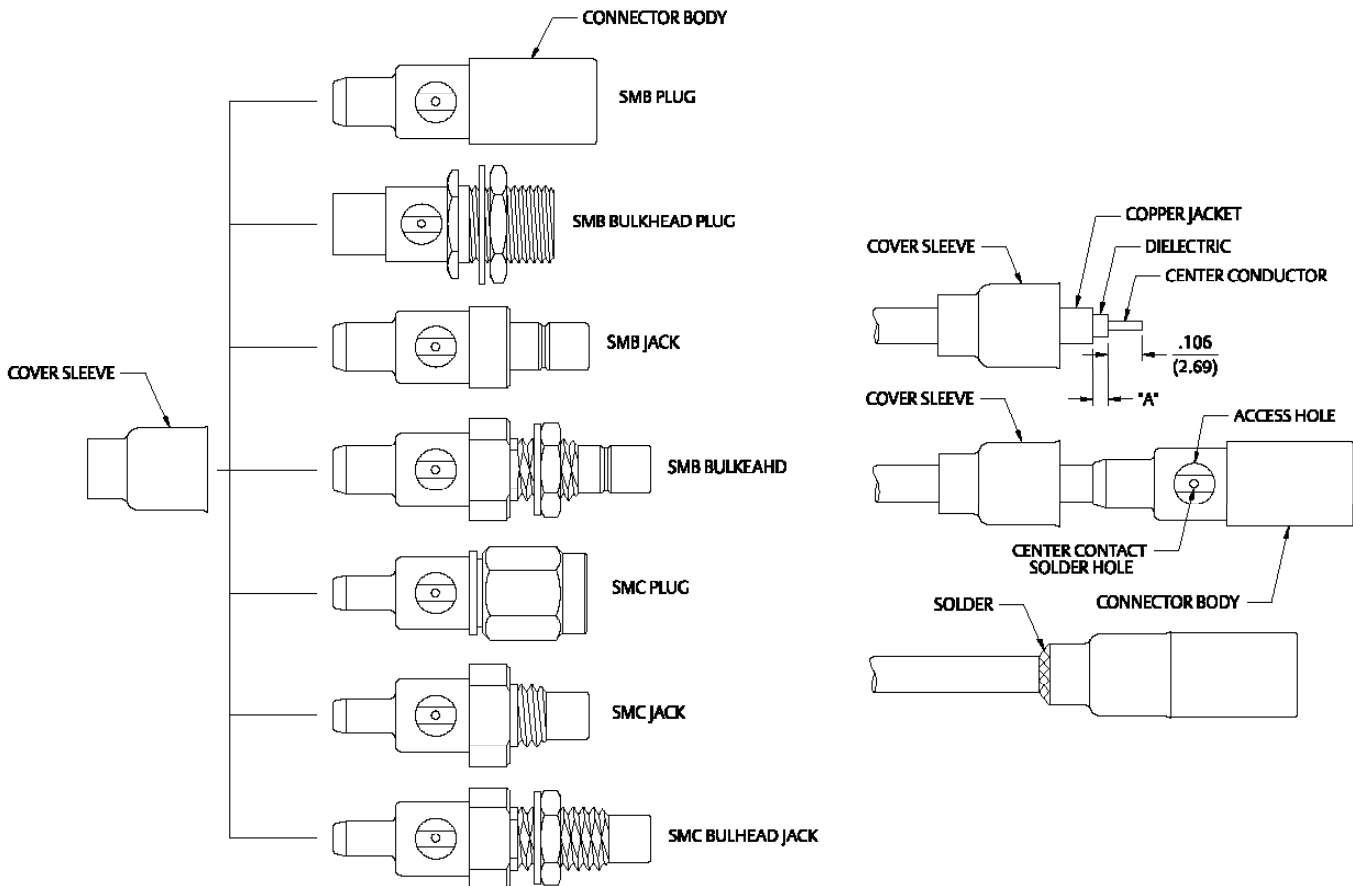

For more information, please contact customer service at (507) 833-8822 or (800) 247-8256 • cinch.com

Illustrations are shown in inches (millimeters).

SMB/SMC Solder Type Right Angle Plugs for Semi-Rigid Cable

1. Identify connector parts. (2 piece parts – except diecast)
2. Strip cable to dimensions shown. Do not nick center conductor.
3. Insert cable into body making certain that the cable insulation bottoms on center contact. Solder center conductor to contact through the rear and side access ports. Use a minimum amount of solder for a good joint. .020 (0.51) diameter solder is recommended.
4. Solder body to cable. Use a minimum amount of heat to minimize cable insulation movement. Place expansion cap in access port and set with .125 (3.17) diameter punch. Snap cover ring over side access port.

Cable Group	Part No.
RG-405/U (.086 Semi-Rigid)	131-1693-101
	131-1693-116
	131-3693-101
	131-3693-116

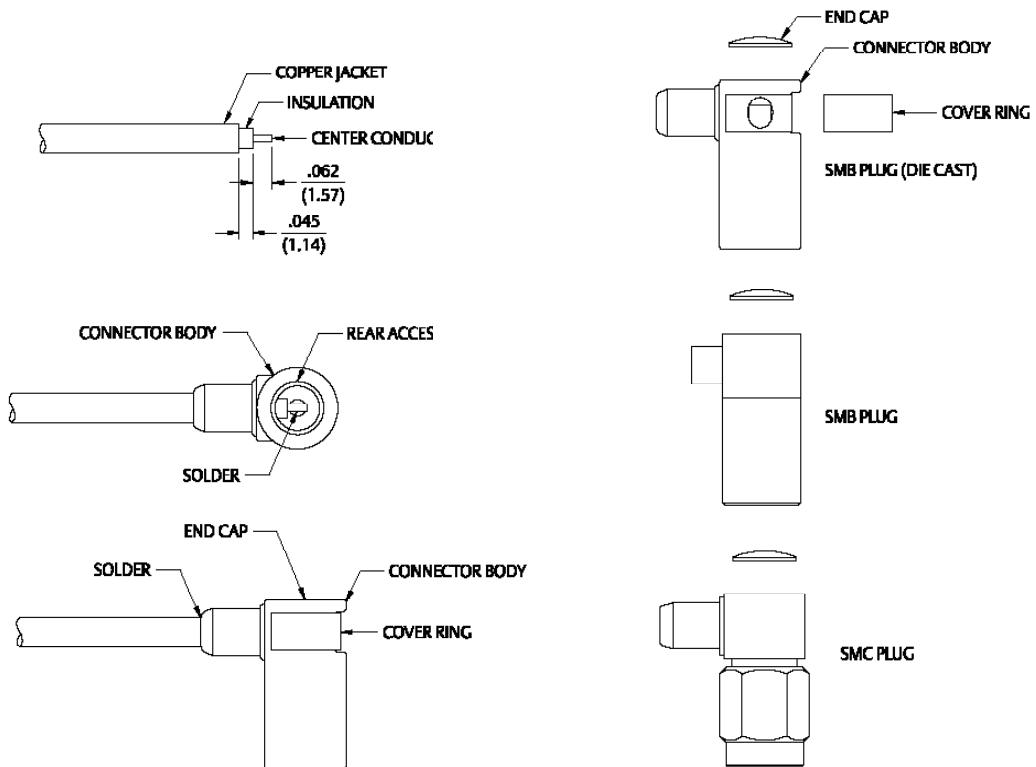

SMB Straight Crimp Type Straight Plugs for Flexible Cable

1. Identify connector parts. (2 piece parts)
2. Strip cable to dimensions shown. Do not nick braid or center conductor. A wire stripper of correct size is recommended for this step. Twist stranded center conductor into tight bundle and tin. Slide crimp sleeve onto cable as shown.
3. Flare braid and slide cable into body making certain that the cable dielectric bottoms against center contact.

Solder Attachment: Solder center conductor to contact through the side access ports and hole in center contact. Use a minimum amount of solder for a full fillet joint. .020 (0.51) diameter solder is recommended.

Crimp Attachment: Crimp contacts with 141-0000-911 dieset in 144-0000-900 tool frame.

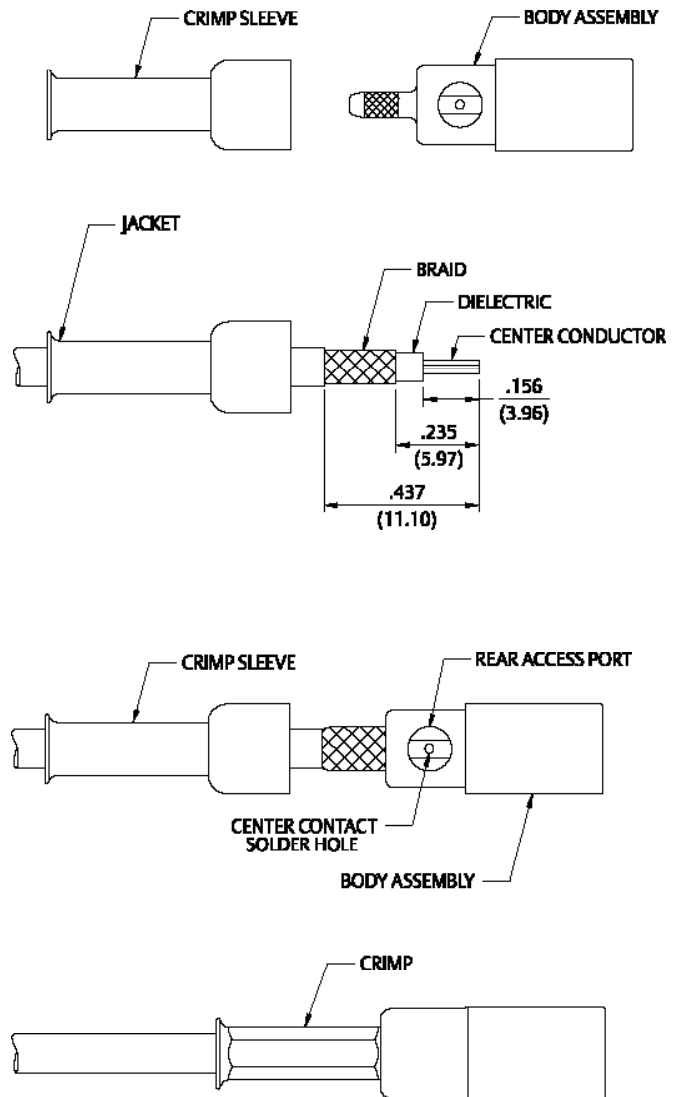

Cable Group	Part No.	Crimp Hex
RG-316/U, 188, 174, 179, 187	131-9403-001	.128 (3.25)
RG-316 DS, 188 DS, 179 DS, 187 DS	131-9404-001	.151 (3.83)

SMB Right Angle Crimp Type Straight Plugs for Flexible Cable

1. Identify connector parts. (3 piece parts: crimp sleeve, body assembly and expansion cap.)
2. Strip cable to dimensions shown. Do not nick braid or center conductor. A wire stripper of correct size is recommended for this step. Twist stranded center conductor into tight bundle and tin (optional). Slide crimp sleeve onto cable as shown.
3. Flare braid and slide cable into body assembly making certain that the cable insulation bottoms on center contact. Arrange braid uniformly around crimp stem of body assembly. Slide crimp sleeve over braid and crimp securely using recommended crimp tool.
4. Solder center conductor to contact through the rear and side access ports. Use a minimum amount of solder for a good joint. .020 (0.51) diameter solder is recommended. Place expansion cap in access port and seat with a .125 (3.17) diameter flat punch. Snap cover ring over side access port.

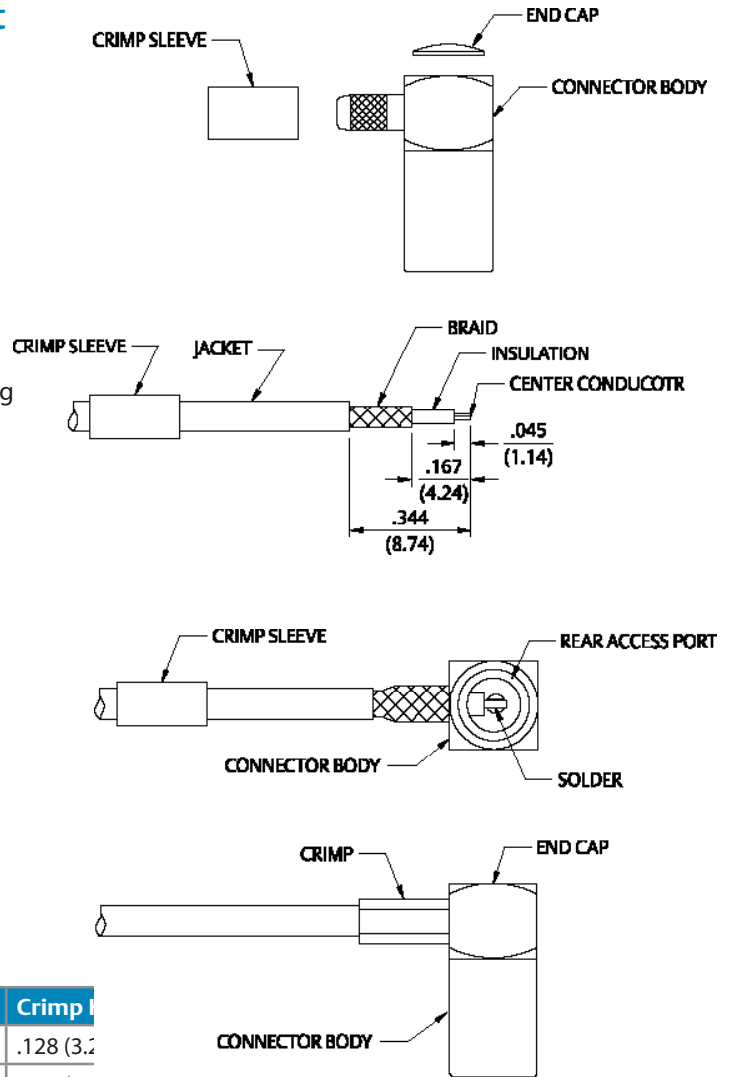

Cable Group	Part No.	Crimp Length
RG-316/U, 188, 174, 179,187	131-9403-101 / -116	.128 (3.2)
RG-316 DS, 188 DS, 179 DS, 187 DS	131-9404-101 / -116	.151 (3.83)

SMB/SMC/Mini-75Ohm SMB (2-Piece) Crimp Type Straight Plugs, Jacks and Bulkhead Jacks for Flexible Cable

1. Identify connector parts. (2 piece parts – except bulkhead)
2. Strip cable to dimensions shown. Do not nick braid or center conductor. A wire stripper of correct size is recommended for this step. Twist stranded center conductor into tight bundle and tin. Slide crimp sleeve onto cable as shown.
3. Flare braid and slide cable into body making certain that the cable dielectric bottoms against center contact.
Solder Attachment: Solder center conductor to contact through the side access ports and hole in center contact. Use a minimum amount of solder for a full fillet joint. .020 (0.51) diameter solder is recommended.
Crimp Attachment: Crimp applicable 50 Ohm connector contacts with 141-0000-911 dieset in 144-0000-900 tool frame. Crimp 75 Ohm connector contacts with 141-0000-924 dieset in 144-0000-900 tool frame. Crimp attachment to solid center conductor cables is not recommended.

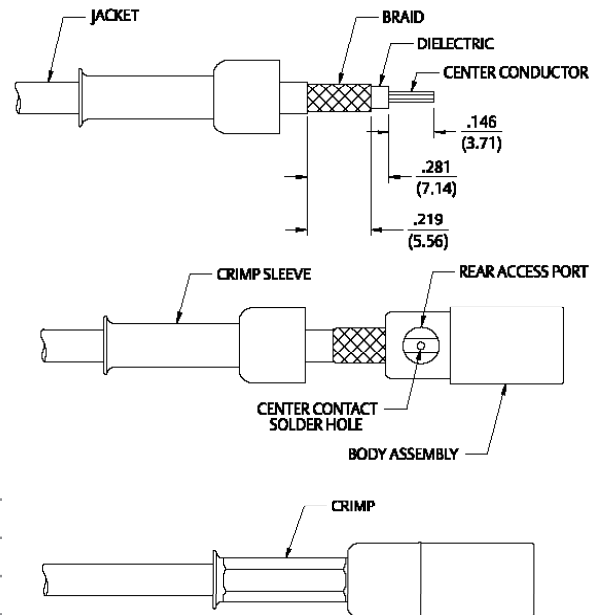
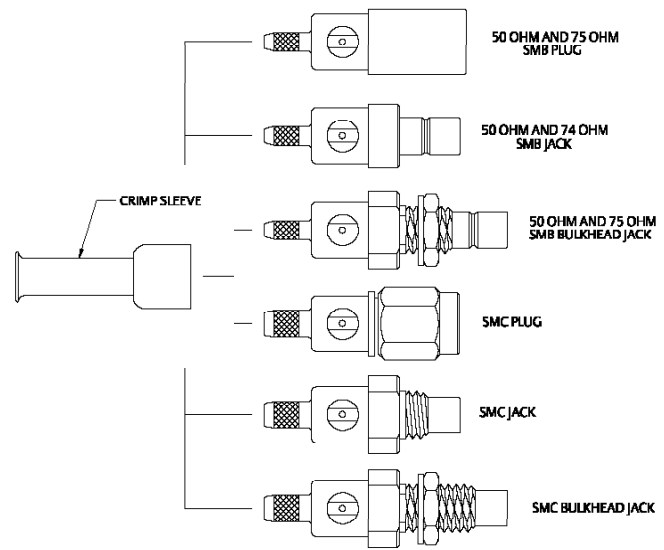

Cable Group	Part No.	Crimp Hex
RG-316/U, 161, 174, 179, 187, 188	131-1403-001/016	.128 (3.25)
RG-316 DS, 188 DS, 179 DS	131-1404-001/016	.151 (3.83)
RG-178/U, 196	131-3302-001/006	.105 (2.67)
RG-316/U, 161, 174, 179, 187, 188	131-3303-001/006 131-3303-401/406	.128 (3.25)
RG-179 DS, 187 DS, 188 DS, 316 DS	131-3304-401/406	.151 (3.83)
RG-178/U, 196	131-3402-001/016	.105 (2.67)
RG-316/U, 161, 174, 179, 187, 188	131-3403-001/016 131-3403-401/406	.128 (3.25)
RG-179 DS, 187 DS, 188 DS, 316 DS	131-3404-401/406 131-3404-001/016	.151 (3.83)
RG-58/U, 141, 303	131-3407-001/006	.213 (5.41)
RG-316/U, 161, 174, 188	131-6303-401/406	.128 (3.25)
RG-316 DS, 188 DS	131-6304-401/406	.151 (3.83)
RG-179/U, 187	131-6333-401/406	.128 (3.25)
RG-316/U, 161, 174, 188	131-6403-001/006	.128 (3.25)
RG-316 DS, 188 DS	131-6404-001/006	.151 (3.83)
RG-179/U, 187	131-6433-001/006	.128 (3.25)
RG-179/U, 187, 316, 161, 174, 188	131-8303-401/406	.128 (3.25)
RG-179 DS, 187 DS, 188DS, 316DS	131-8304-401/406	.151 (3.83)
RG-179/U, 187, 316, 161, 174, 188	131-8403-001/006 131-8403-011/016	.128 (3.25)
RG-179 DS, 187 DS, 188 DS, 316 DS	131-8404-001/006 131-8404-011/016	.151 (3.83)
RG-59	131-8409-001/006	.255 (6.48)
BELDEN 735A	131-8445-001/006	.178 (4.52)

For more information, please contact customer service at (507) 833-8822 or (800) 247-8256 • cinch.com

Illustrations are shown in inches (millimeters).

SMB/SMC/Mini-75Ohm SMB Crimp Type Right Angle Plugs and Right Angle Bulkhead Jacks for Flexible Cable

- Identify connector parts. (4 piece parts: crimp sleeve, body assembly, expansion cap and covering ring. Die cast body only.)
- Strip cable to dimensions shown. Do not nick braid or center conductor. A wire stripper of correct size is recommended for this step. Twist stranded center conductor into tight bundle and tin (optional). Slide crimp sleeve onto cable as shown.
- Flare braid and slide cable into body assembly making certain that the cable insulation bottoms on center contact. Arrange braid uniformly around crimp stem of body assembly. Slide crimp sleeve over braid and crimp securely using recommended crimp tool.

- Solder center conductor to contact through the rear and side access ports. Use a minimum amount of solder for a good joint. .020 (0.51) diameter solder is recommended. Place expansion cap in access port and seat with a .125 (3.17) diameter flat punch. Snap cover ring over side access port if applicable.

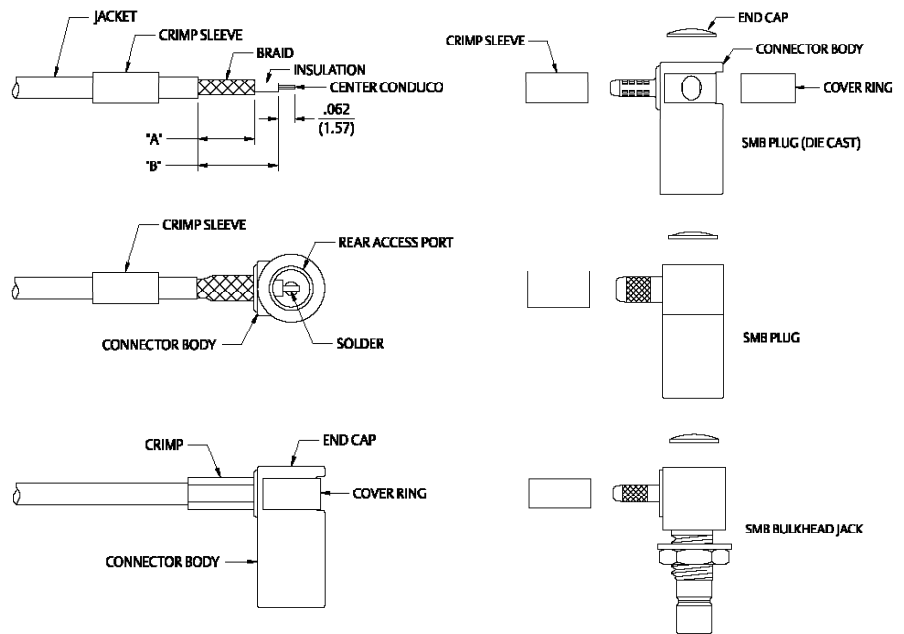

Cable Group	Part No.	"A"	"B"	Crimp Hex
RG-178/U, 196	131-1402-101/116	.219 (5.56)	.312 (7.92)	.105 (2.67)
RG-316/U, 161, 174, 179, 187, 188	131-1403-101/116	.219 (5.56)	.312 (7.92)	.128 (3.25)
RG-179 DS, 187 DS, 188 DS, 316 DS	131-1404-101/116	.219 (5.56)	.312 (7.92)	.151 (3.83)
RG-316/U, 161, 174, 179, 187, 188	131-3303-501/506	.219 (5.56)	.312 (7.92)	.128 (3.25)
RG-179 DS, 187 DS, 188 DS, 316 DS	131-3304-501/506	.219 (5.56)	.312 (7.92)	.151 (3.83)
RG-178/U, 196	131-3402-101/116	.177 (4.50)	.289 (7.34)	.105 (2.67)
RG-316/U, 161, 174, 179, 187, 188	131-3403-101/116	.177 (4.50)	.289 (7.34)	.128 (3.25)
RG-179 DS, 187 DS, 188 DS, 316 DS	131-3404-101/116	.177 (4.50)	.289 (7.34)	.151 (3.83)
RG-58/U, 141, 303	131-3407-101/106	.219 (5.56)	.289 (7.34)	.213 (5.41)
RG-316/U, 161, 174, 188	131-6403-101/106	.219 (5.56)	.312 (7.92)	.128 (3.25)
316 DS, 188 DS	131-6404-101/106	.219 (5.56)	.312 (7.92)	.151 (3.83)
RG-179/U, 187	131-6433-101/106	.219 (5.56)	.312 (7.92)	.151 (3.83)
RG-179/U, 187, 316, 161, 174, 188	131-8403-101/106	.177 (4.50)	.289 (7.34)	.128 (3.25)
RG-179 DS, 187 DS	131-8404-101/106	.177 (4.50)	.289 (7.34)	.151 (3.83)
316 DS, 188 DS	131-8404-111/116	.219 (5.56)	.312 (7.92)	.151 (3.83)
RG-59	131-8409-101/106	.219 (5.56)	.289 (7.34)	.255 (6.48)
BELDEN 735A	131-8445-101/106	.177 (4.50)	.289 (7.34)	.178 (4.52)
RG-316/U, 188, 174, 179, 187	131-9403-101/116	.177 (4.50)	.289 (7.34)	.128 (3.25)
RG-316 DS, 188 DS, 179 DS, 187 DS	131-9404-101/116	.177 (4.50)	.289 (7.34)	.151 (3.83)

Type N Crimp Type Bulkhead Jack for Flexible Cable

1. Identify connector parts. (6 piece parts)
2. Strip cable to dimensions shown. Do not nick braid or center conductor. A wire stripper of correct size is recommended for this step. Twist stranded center conductor into a tight bundle and tin (optional). Slide crimp sleeve onto cable as shown.
3. Flare body and slide cable into crimp stem of rear body subassembly, until cable dielectric bottoms out on center contact. Solder center conductor to contact through the solder hole. Solder must not be allowed to gather and run on outside of contact. Use a minimum amount of solder for a good joint. .020 (0.51) diameter solder is recommended.
4. Arrange braid uniformly around crimp stem. Slide crimp sleeve over braid and crimp securely using recommended crimp tool. Slide insulator over center conductor and slide center contact assembly into connector body. Thread rear body subassembly into body and tighten securely (ref. 30 in-lbs torque.)

Cable Group	Part No.	Crimp Hex
RG-316/U, 161, 174, 188	134-0303-406	.160 (4.06)
RG-316 DS, 188 DS	134-0304-406	.160 (4.06)
RG-58/U, 141, 303	134-0307-406	.213 (5.41)
RG-55/U, 142, 223, 400	134-0308-406	.213 (5.41)

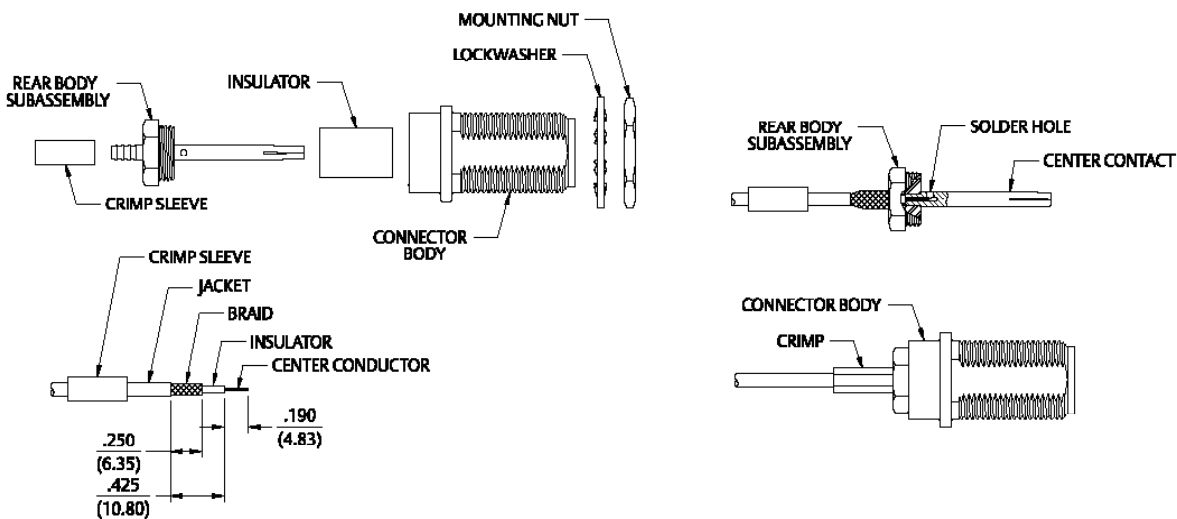

For more information, please contact customer service at (507) 833-8822 or (800) 247-8256 • cinch.com
Illustrations are shown in inches (millimeters).

Type N Straight Crimp Type Plugs for Flexible Cable

1. Identify connector parts. (3 piece parts – except bulkheads)
2. Strip cable to dimensions shown. Do not nick braid or center conductor. Tin center conductor if contact will be solder attached. Do not tin center conductor if contact is to be crimp attached. A wire stripper of correct size is recommended for this step. Slide heat shrink (as applicable) and crimp sleeve onto jacket of cable.
3. Assemble contact onto cable as shown.
Solder Attachment: Solder contact to center conductor through hole using a minimum amount of solder for a good joint.
Crimp Attachment (where applicable): Crimp contact to center conductor using recommended crimp hex.
4. Flare braid and slide body assembly over contact and under braid. Then seat body assembly firmly onto contact. The cable may have to be held in a clamping fixture. Arrange braid uniformly around crimp stem. Slide crimp sleeve forward and crimp using recommended crimp hex. Slide heat shrink forward and shrink (as applicable).

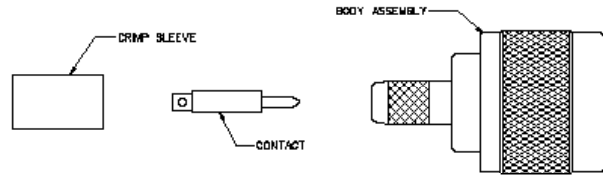

A

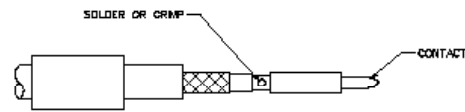
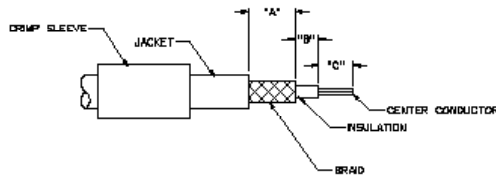

B

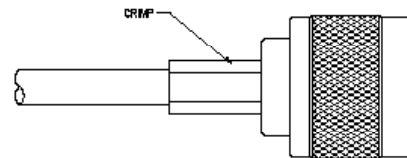
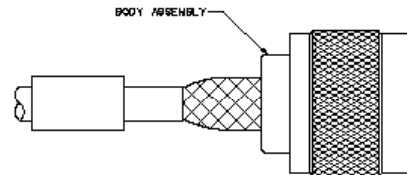

C

Part No.	Cable	Strip Dimensions			Crimp Sleeve Hex	Contact Crimp Hex	Recommended Crimp
		"A"	"B"	"C"			
CPN681	RG-58	.335 (8.50)	.079 (2.00)	.157 (4.00)	.215 (5.46)	.065 (1.65)	24-8858P
CPN6813	RG-142	.335 (8.50)	.079 (2.00)	.157 (4.00)	.215 (5.46)	.065 (1.65)	24-8858P
CPN688	RG-8, 213	.354 (9.00)	.138 (3.50)	.157 (4.00)	.429 (10.90)	.100 (2.54)	24-313
138-4408-007	RG-55/U, 142, 223, 400	.301 (7.65)	.140 (3.56)		.213 (5.41)	.068 (1.73)	.113 (2.87)
138-4449-007	LMR-400, BELDEN 9913	.385 (9.78)	.170 (4.32)		.429 (10.90)	.116 (2.95)	

Type N Crimp – Crimp Plugs for Flexible Cable

1. Identify connector parts. (3 piece parts)
2. Strip cable to dimensions shown. Do not nick braid or center conductor. Slide the crimp sleeve onto the jacket; crimp narrow end first.
3. Crimp and solder the contact onto the center conductor using the recommended crimp hex or the minimum amount of solder for a good joint. Note: Contacts may need to be pre-fit onto the center conductor and soldered through the hole.
4. Flare the braid and slide the connector body over the contact and under the braid. Then seat the body FIRMLY onto the contact; the cable may need to be held in a clamping fixture. Arrange the braid uniformly around the crimp stem, then slide the crimp sleeve forward to the body and crimp the sleeve using the recommended crimp hex.

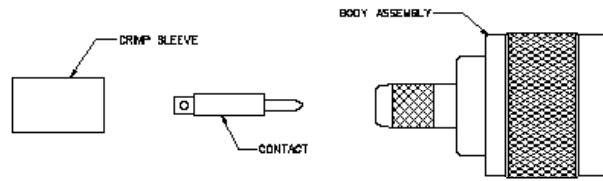

A

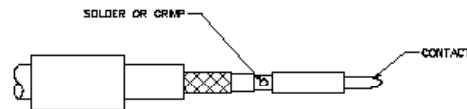
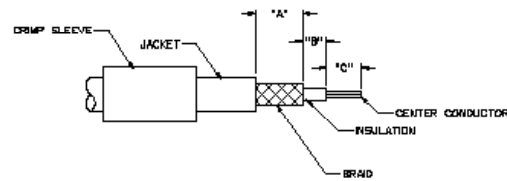

B

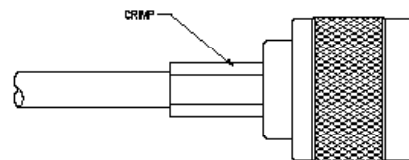
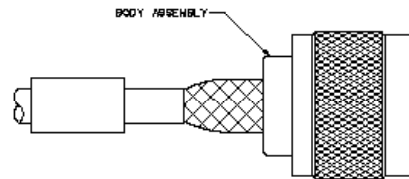

C

* Cable Assembly Notes: The contact of the CPN-8/110 Connector fits RG-8 cable types with a center conductor diameter up to .110".

Part No.	Cable Type	Wire Gauge	Wire Decimal	Jacket O.D.	Hex Size	Contact Crimp Hex	Recommended Crimp Tool
CPN-1	RG-58	18	.043 (1.09)	.185 (4.07)- .205 (5.21)	.213 (5.41)	.100 (2.54)	24-312
CPN-2	RG-59	22	.0253 (6.43)	.220 (5.59)- .250 (6.35)	.255 (6.48)	.100 (2.54)	24-312
CPN-8	RG-8, 213	13	.072 (1.83)	.400 (10.16)- .410 (10.44)	.406 (10.31)	.102 (2.59)	24-7712P
CPN-8/110*	RG-58 Low Loss, 213	10	.110 (2.80)	.400 (10.16)- .410 (10.44)	.406 (10.31)	.102 (2.59)	24-7712P
CPN-16	Proflex RG-450	18	.056 (1.42)	.220 (5.59)- .250 (6.35)	.255 (6.48)	.100 (2.54)	24-312
CPN-17	RG-8X	16	.065 (1.65)	.220 (5.59)- .250 (6.35)	.255 (6.48)	.100 (2.54)	24-312
CPN-142T	RG-142TFE	20	.034 (0.86)	.200 (5.08)- .220 (5.59)	.213 (5.41)	.100 (2.54)	24-312

For more information, please contact customer service at (507) 833-8822 or (800) 247-8256 • cinch.com

Illustrations are shown in inches (millimeters).

Type N Straight Plug Crimp Style for RG-316 and 316DS Flexible Cable

- 1 Identify connector parts. (3 piece parts)
- 2 Strip cable to dimensions shown. Do not nick center conductor. A wire stripper of correct size is recommended for this step. Tin center conductor if contact will be solder attached. Do not tin center conductor if contact will be crimp attached. Slide crimp sleeve onto jacket of cable.
3. Assemble rear contact onto cable as shown
Rear contact should butt against cable dielectric during attachment.
Solder Attachment: Solder rear contact to center conductor through solder hole using .020 (.051) diameter flux core solder wire. Use a minimum amount of solder for a good joint.
Crimp Attachment: Crimp rear contact to center conductor using Johnson indent hand tool 140-0000-970. Crimp location should be centered between end of rear contact and solder hole using positioning tool 140-0000-971. Crimp attachment to solid center conductor cables is not recommended.
4. Flare braid and slide plug connector assembly over rear contact and under braid. Rear contact must engage fully with internal captivated plug contact. Cable jacket should be located near end of crimp stem when contacts are fully engaged.
5. Arrange braid uniformly around crimp stem. Slide crimp sleeve forward and crimp using Johnson ergonomic hand crimp frame 140-0000-967 with recommended hex size die set. Maintain forward pressure on cable while crimping.

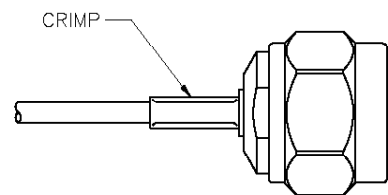
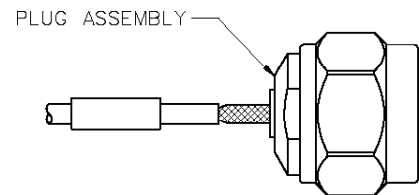
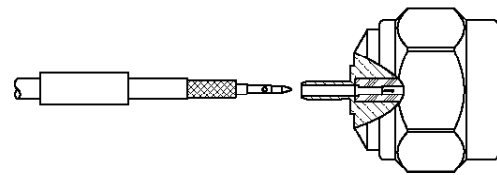
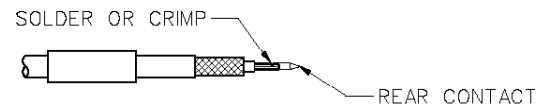
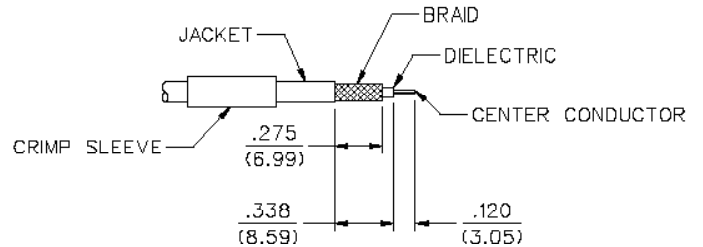
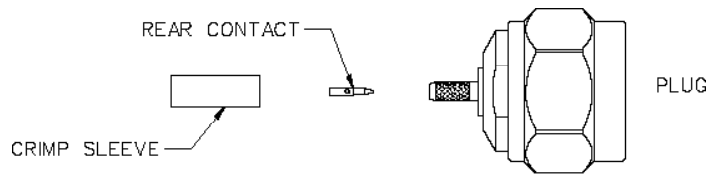

Cable Group	Part No.	Crimp Sleeve Hex Size	Contact Crimp
RG-316/U, 161, 174, 188	138-4403-007	.128 (3.25)	8 INDENT
RG-316 DS, 188 DS	138-4404-007	.151 (3.84)	8 INDENT

	Assembly
Tool	138-4403/4404-007
Crimp Frame	140-0000-967
Die Set	140-0000-990
Contact Tool	140-0000-970
Positioner	140-0000-971

Type N Straight Plug Crimp Style for RG-58, 142, 213, 214 and LMR-400 Flexible Cable

1. Identify connector parts. (3 piece parts)
2. Strip cable to dimensions shown. Do not nick center conductor. A wire stripper of correct size is recommended for this step. Tin center conductor if contact will be solder attached. Do not tin center conductor if contact will be crimp attached. Slide crimp sleeve onto jacket of cable.
3. Assemble plug contact onto cable as shown. Plug contact should butt against cable dielectric during attachment.
Solder Attachment: Solder plug contact to center conductor through solder hole using .020 (.051) diameter flux core solder wire. Use a minimum amount of solder for a good joint.
Crimp Attachment: Crimp plug contact to center conductor using Johnson ergonomic hand crimp frame 140-0000-967 with recommended hex size die set. Crimp location should be on end of plug contact next to cable dielectric. Crimp attachment to solid center conductor cables is not recommended.
4. Flare braid and slide plug connector assembly over plug contact and under braid. Seat plug connector assembly firmly onto contact. Arrange braid uniformly around crimp stem. Slide crimp sleeve forward and crimp using Johnson ergonomic hand crimp frame 140-0000-967 with recommended hex size die set. Maintain forward pressure on cable while crimping.

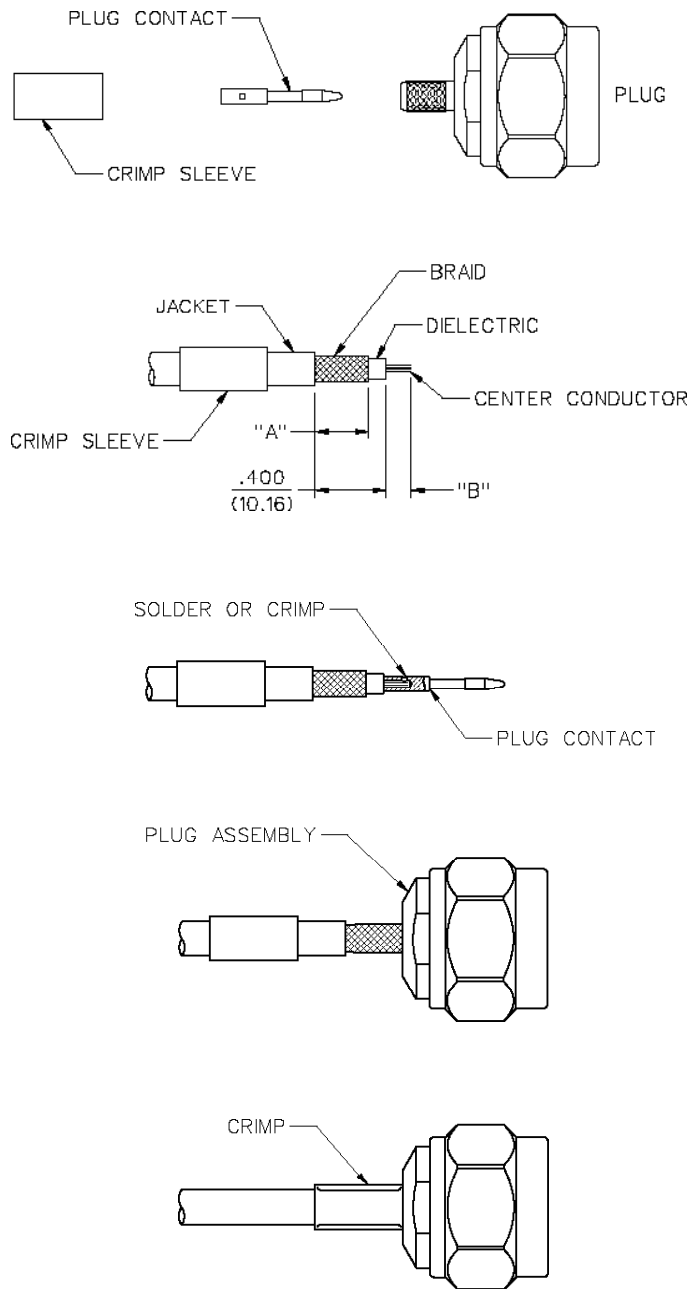

Cable Group	Part No.	"A"	"B"	Crimp Sleeve Hex Size	Contact Hex Size
RG-58/U, 141, 303	138-4407-007	.301 (7.65)	.140 (3.56)	.213 (5.41)	.068 (1.73)
RG-55/U, 142, 223, 400	138-4408-007	.301 (7.65)	.140 (3.56)	.213 (5.41)	.068 (1.73)
RG-8, 213	138-4416-007	.385 (9.78)	.170 (4.32)	.429 (10.90)	.111 (2.82)
RG-9, 214	138-4418-007	.385 (9.78)	.170 (4.32)	.429 (10.90)	.111 (2.82)
LMR-400, BELDEN 9913	138-4449-007	.385 (9.78)	.170 (4.32)	.429 (10.90)	.116 (2.95)

Assembly		
Tool	138-4407/4408-007	138-4416/4418/4449-007
Crimp Frame	140-0000-967	140-0000-967
Die Set	140-0000-990	140-0000-991

For more information, please contact customer service at (507) 833-8822 or (800) 247-8256 • cinch.com

Illustrations are shown in inches (millimeters).

Type N Right Angle Plug Crimp Style for RG-316, 316DX, 58, and 142 Flexible Cable

1. Identify connector parts. (3 piece parts)
2. Strip cable to dimensions shown. Do not nick center conductor. A wire stripper of correct size is recommended for this step. Twist stranded center conductor into tight bundle and tin (optional). Slide crimp sleeve onto jacket of cable.
3. Flare braid and slide plug connector assembly over cable dielectric and under braid. Make sure cable dielectric bottoms against plug contact as shown. Solder center conductor to contact through rear access port. Use a minimum amount of solder for a full fillet joint.
4. Arrange braid uniformly around crimp stem. Slide crimp sleeve forward and crimp using Johnson ergonomic hand crimp frame 140-0000-967 with recommended hex size die set. Screw end cap into access port.

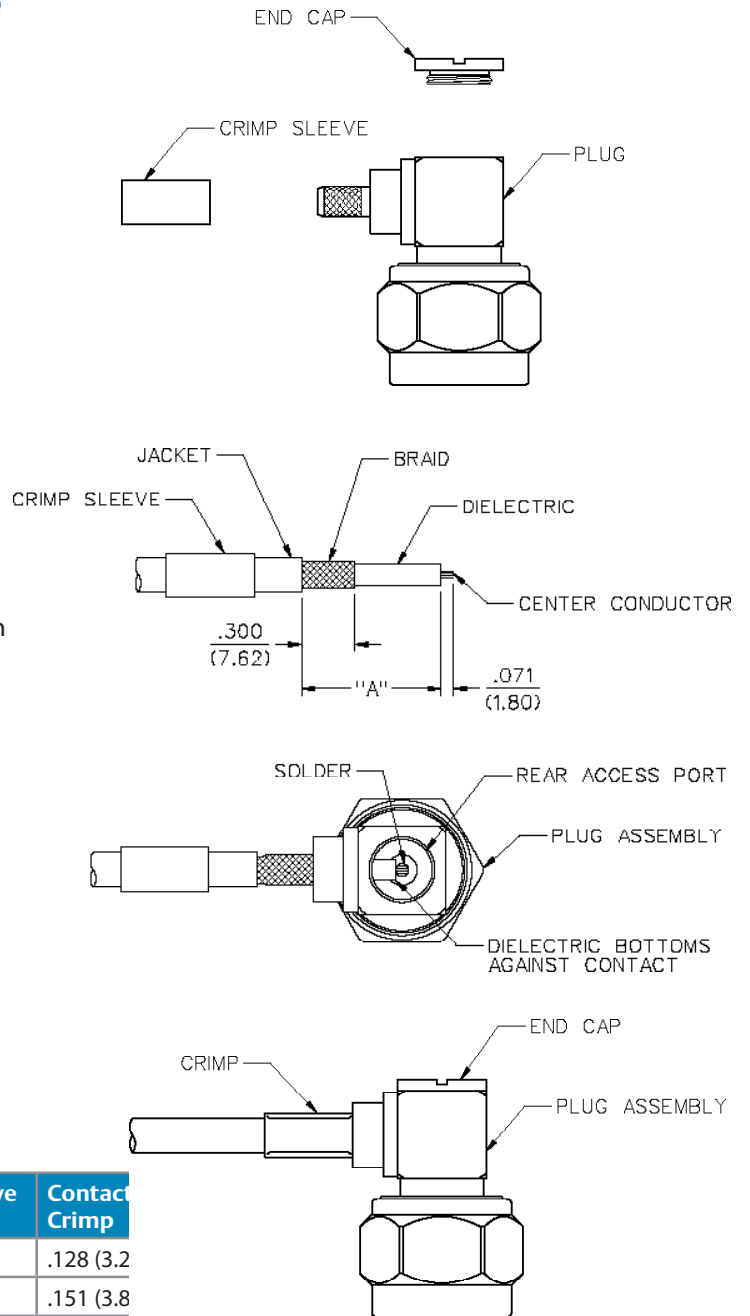

Cable Group	Part No.	Crimp Sleeve Hex Size	Contact Crimp
RG-316/U, 161, 174, 188	138-4403-107	.755 (19.18)	.128 (3.2)
RG-316 DS, 188 DS	138-4404-107	.755 (19.18)	.151 (3.8)
RG-58/U, 141, 303	138-4407-107	.788 (20.02)	.213 (5.41)
RG-55/U, 142, 223, 400	138-4408-107	.788 (20.02)	.213 (5.41)

	Assembly
Tool	138-4403/4404/4407/4408-107
Crimp Frame	140-0000-967
Die Set	140-0000-990

Type N Right Angle Plug Crimp Style for RG-213 and 214 Flexible Cable

1. Identify connector parts. (3 piece parts)
2. Strip cable to dimensions shown. Do not nick center conductor. A wire stripper of correct size is recommended for this step. Slide crimp sleeve onto jacket of cable.
3. Flare braid and slide plug connector assembly over cable dielectric and under braid. Make sure center conductor is contained within plug contact as shown. Center conductor should not protrude above slots in plug contact and cable dielectric should not touch plug contact. Solder center conductor to plug contact through rear access port. Use a minimum amount of solder for a full fillet joint.
4. Arrange braid uniformly around crimp stem. Slide crimp sleeve forward and crimp using Johnson ergonomic hand crimp frame 140-0000-967 with recommended hex size die set. Screw end cap into access port.

Cable Group	Part No.	Contact Crimp
RG-8, 213	138-4416-107	.429 (10.90)
RG-9, 214	138-4418-107	.429 (10.90)

	Assembly
Tool	138-4416/4418-107
Crimp Frame	140-0000-967
Die Set	140-0000-991

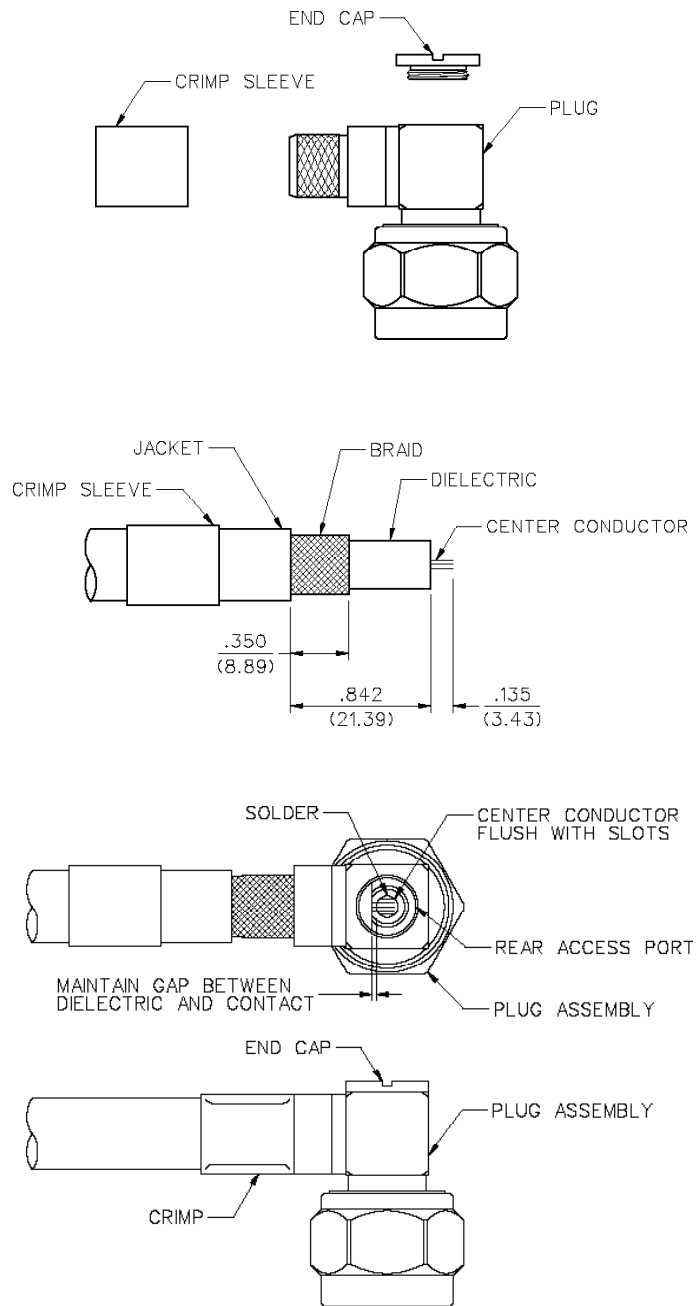

For more information, please contact customer service at (507) 833-8822 or (800) 247-8256 • cinch.com

Illustrations are shown in inches (millimeters).

Type N Straight Plug Solder Style for Semi-Rigid Cable

1. Identify connector parts (2 piece parts) and tools (5 piece parts).
2. Strip cable jacket and dielectric to dimension shown. Do not nick center conductor. Clean all debris from cable.
3. Place plug contact onto center conductor, insert appropriate sized solder shim between cable jacket and contact.
4. Insert contact into location fixture and clamp cable in vise. Tighten stop screw until light pressure is applied between contact, solder shim and cable jacket.
5. Solder contact to center conductor through solder hole using .020 (.051) diameter flux core solder wire. Use a minimum amount of solder for a good joint.
6. After solder joint has cooled, loosen stop screw and remove solder shim. Remove cable from vise and remove any excess solder from contact with a sharp blade and clean all debris from contact and cable.
7. Insert contact and cable into plug connector assembly, making sure cable jacket bottoms out against internal shoulder of connector assembly. Insert location fixture into connector assembly and clamp cable in vise. Tighten stop screw until light pressure is applied between connector assembly and cable jacket.
8. Solder connector body to cable jacket, using a minimum amount of solder for a full fillet joint. Allow assembly to cool before removing connector from vise.

Cable Group	Part No.	"A"
RG-405, .086 Semi-Rigid	138-4693-001	.085 (2.16)
RG-402, .141 Semi-Rigid	138-4694-001	.085 (2.16)
RG-401, .250 Semi-Rigid	138-4696-001	.100 (2.54)

Assembly			
Tool	138-4693-001	138-4694-001	138-4696-001
Solder Shim	140-0000-984	140-0000-984	140-0000-985
Location Fixture	140-0000-983	140-0000-983	140-0000-983
Cable Vise	140-0000-962	140-0000-962	140-0000-962
Clamp Inserts	140-0000-964	140-0000-965	140-0000-986

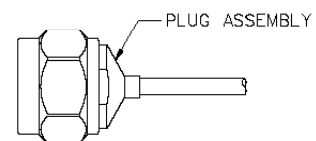
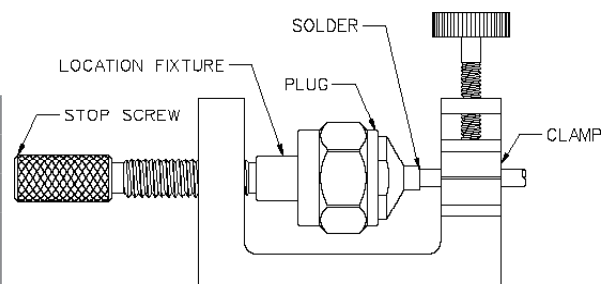
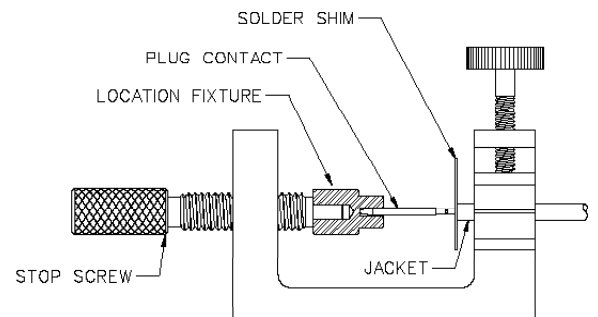
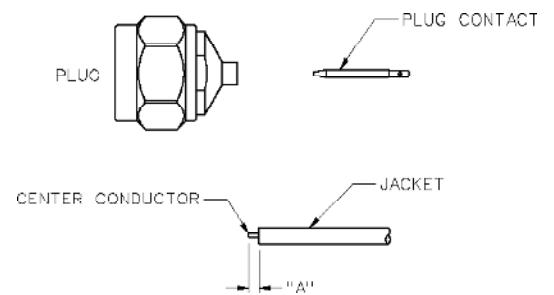
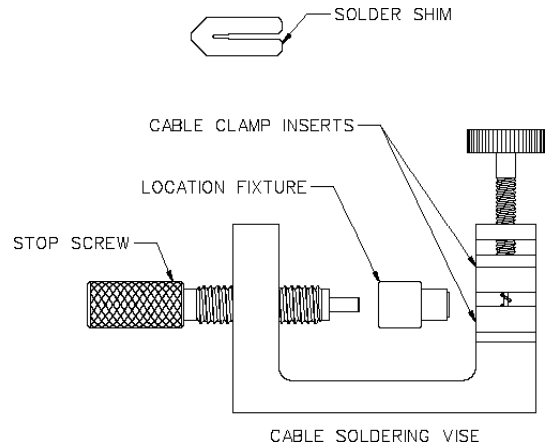

Type N Straight Plug One Piece Style for Semi-Rigid Cable

1. Identify connector and tools. (4 piece parts)
2. Strip cable jacket and dielectric to dimension shown. Do not nick center conductor.
3. Bevel end of cable center conductor per appropriate dimensional profile.
4. Clean all debris from prepared cable and insert cable into connector assembly, making sure cable jacket bottoms out against internal shoulder of connector assembly and center conductor engages with internal captivated plug contact.
5. Insert location fixture into connector assembly and clamp cable in vise. Tighten stop screw until light pressure is applied between connector assembly and cable jacket.
6. Solder connector body to cable jacket, using a minimum amount of solder for a full fillet joint. Allow assembly to cool before removing connector from vise.

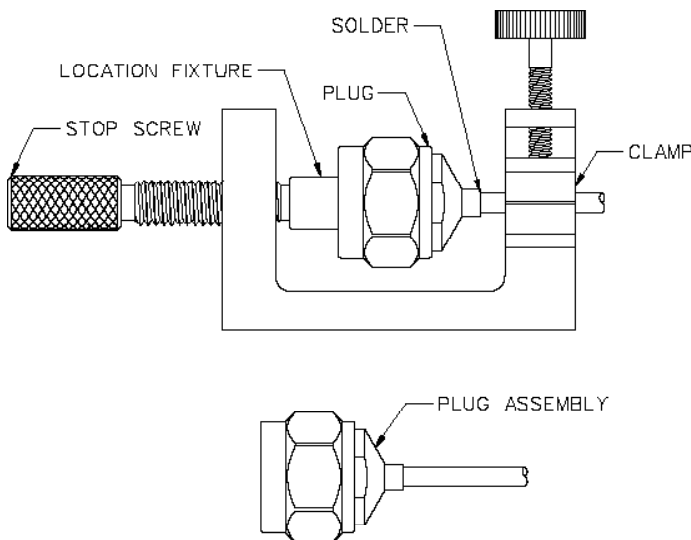
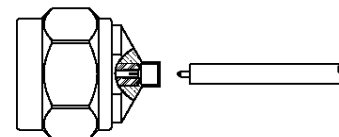
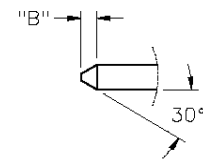
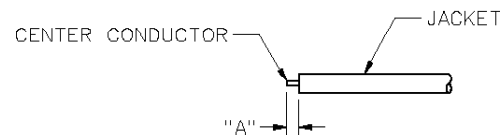
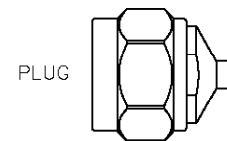
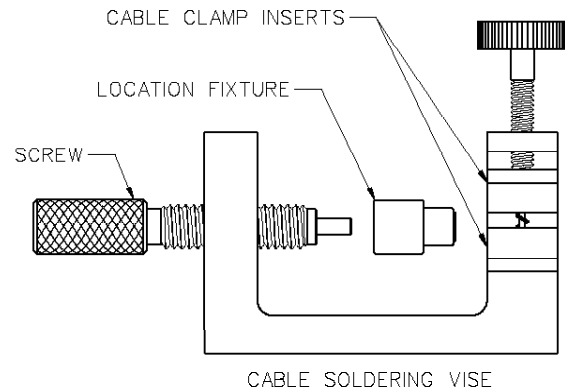

Cable Group	Part No.	"A"	"B"
RG-405, .086 Semi-Rigid	138-4693-011	.085 (2.16)	.014 (0.36)
RG-402, .141 Semi-Rigid	138-4694-011	.085 (2.16)	.022 (0.56)
RG-401, .250 Semi-Rigid	138-4696-011	.150 (3.81)	.045 (1.14)

Assembly			
Location Fixture	140-0000-983	140-0000-983	140-0000-983
Cable Vise	140-0000-962	140-0000-962	140-0000-962
Clamp Inserts	140-0000-964	140-0000-965	140-0000-986
Stop Screw	140-0000-981	140-0000-981	140-0000-981

For more information, please contact customer service at (507) 833-8822 or (800) 247-8256 • cinch.com

Illustrations are shown in inches (millimeters).

Type N Bulkhead Jack Crimp Style for RG-316 and 316DS Flexible Cable

1. Identify connector parts. (6 piece parts)
2. Strip cable to dimensions shown. Do not nick center conductor. A wire stripper of correct size is recommended for this step. Tin center conductor if contact will be solder attached. Do not tin center conductor if contact will be crimp attached. Slide crimp sleeve onto jacket of cable.

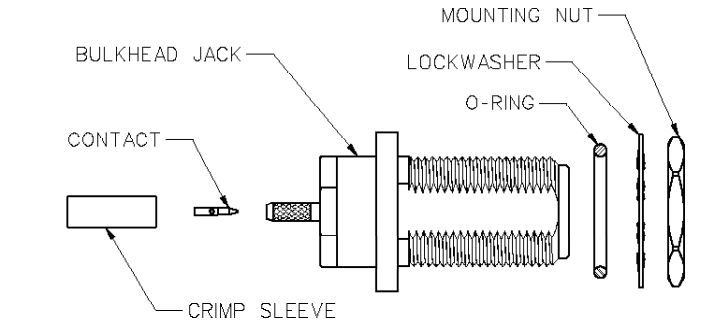

3. Assemble rear contact onto cable as shown. Rear contact should butt against cable dielectric during attachment.

Solder Attachment: Solder rear contact to center conductor through solder hole using .020 (.051) diameter flux core solder wire. Use a minimum amount of solder for a good joint.

Crimp Attachment: Crimp rear contact to center conductor using Johnson indent hand tool 140-0000-970. Crimp location should be centered between end of rear contact and solder hole using positioning tool 140-0000-971. Crimp attachment to solid center conductor cables is not recommended.

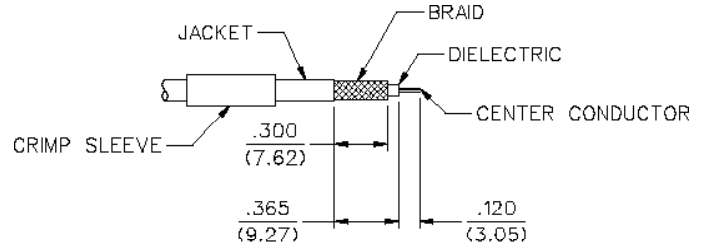

4. Flare braid and slide bulkhead jack connector assembly over rear contact and under braid. Rear contact must engage fully with internal captivated jack contact. Cable jacket should be located near end of crimp stem when contacts are fully engaged.

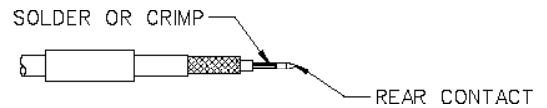

5. Arrange braid uniformly around crimp stem. Slide crimp sleeve forward and crimp using Johnson ergonomic hand crimp frame 140-0000-967 with recommended hex size die set. Maintain forward pressure on cable while crimping.

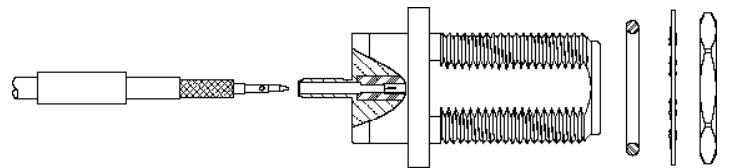

6. Add gasket, lock washer and mounting nut when installing.

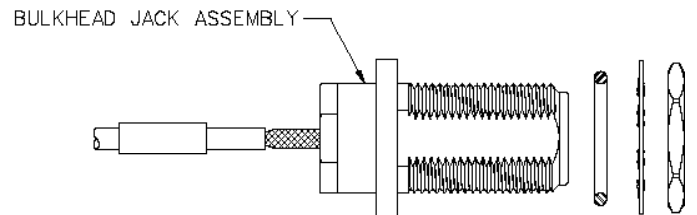
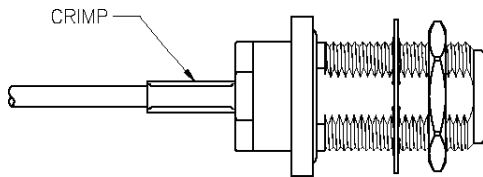

Cable Group	Part No.	Crimp Sleeve Hex Size	Contact Crimp
RG-316/U, 161, 174, 188	138-4303-407	.128 (3.25)	8 INDENT
RG-316 DS, 188 DS	138-4304-407	.151 (3.84)	8 INDENT

Assembly	
Die Set	140-0000-990
Contact Tool	140-0000-970
Positioner	140-0000-971

Type N Bulkhead Jack Solder Style for Semi-Rigid Cable

1. Identify connector parts (8 piece parts) and tools (4 piece parts).
2. Strip cable jacket and dielectric to dimension shown. Do not nick center conductor. Clean all debris from cable.
3. Slide stem over cable jacket, keeping stem correctly oriented to end of cable.
4. Insert jack contact into rear insulator. Make sure insulator is correctly oriented to contact. Place jack contact and rear insulator onto center conductor, keeping insulator correctly oriented between cable jacket and contact.
5. Slide stem away from jack contact. Insert contact into stop screw and clamp cable in vise. Tighten stop screw until light pressure is applied between jack contact, rear insulator and cable jacket.
6. Solder jack contact to center conductor through solder hole using .020 (.051) diameter flux core solder wire. Use a minimum amount of solder for a good joint.
7. After solder joint has cooled, remove cable from vise and remove any excess solder from jack contact with a sharp blade and clean all debris from contact and rear insulator.
8. Slide stem over rear insulator and tighten stem into location fixture until stem bottoms out.
9. Insert cable into vise, but do not clamp. Insert jack contact into stop screw and tighten location fixture until stop screw bottoms out. Clamp cable in vise.
10. Solder stem to cable jacket, using a minimum amount of solder for a full fillet joint. Allow assembly to cool before removing from vise.
11. After solder joint has cooled, un-clamp cable and remove location fixture from stop screw and cable assembly. Insert front insulator into bulkhead jack body. Insert cable assembly into body and tighten to 25-30 in-lbs.
12. Add gasket, lock washer and mounting nut when installing connector to panel.

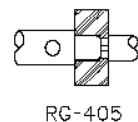
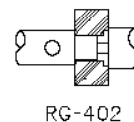
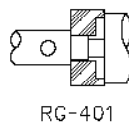
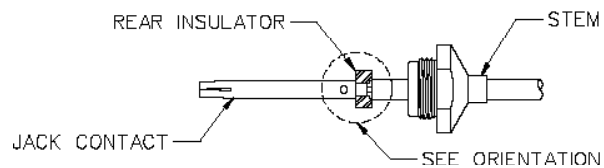
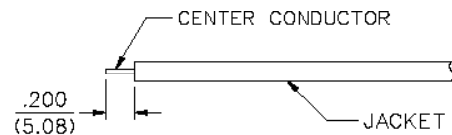
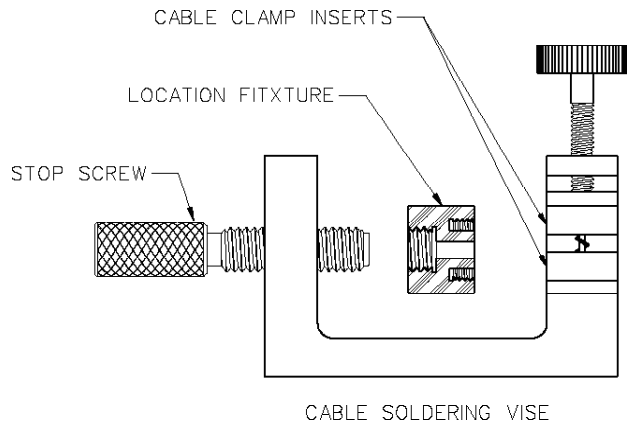
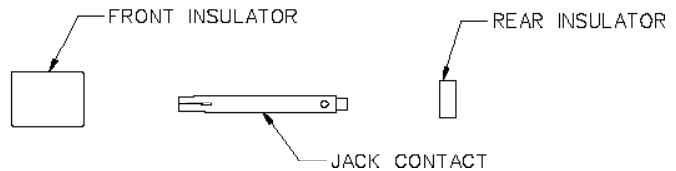
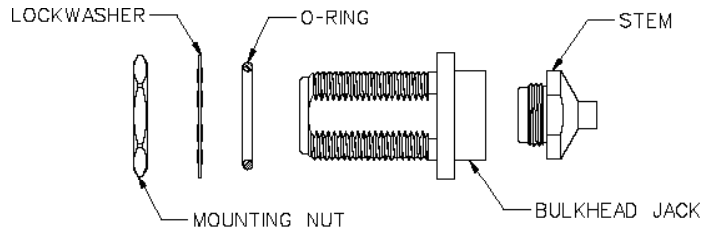

Type N Bulkhead Jack Solder Style for Semi-Rigid Cable (cont'd from last page)

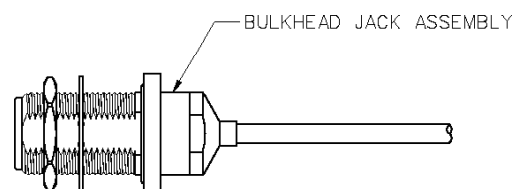
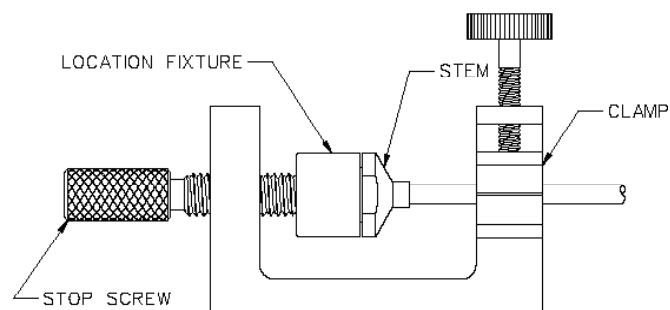
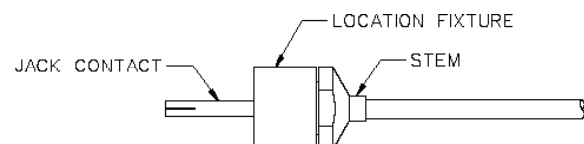
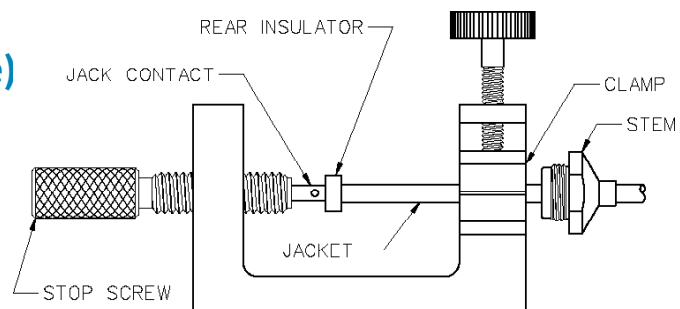

Cable Group	Part No.
RG-405, .086 Semi-Rigid	138-4593-401
RG-402, .141 Semi-Rigid	138-4594-401
RG-401, .250 Semi-Rigid	138-4596-401

Assembly			
Tool	138-4593-401	138-4594-401	138-4596-401
Stop Screw	140-0000-972	140-0000-972	140-0000-972
Cable Vise	140-0000-962	140-0000-962	140-0000-962
Clamp Inserts	140-0000-964	140-0000-965	140-0000-986
Location Fixture	140-0000-987	140-0000-988	140-0000-989

Type N Bulkhead Jack Crimp Style for RG-58, 142, 213, 214 and LMR-400 Flexible Cable

1. Identify connector parts. (6 piece parts)
2. Strip cable to dimensions shown. Do not nick center conductor. A wire stripper of correct size is recommended for this step. Tin center conductor if contact will be solder attached. Do not tin center conductor if contact will be crimp attached. Slide crimp sleeve onto jacket of cable.
3. Assemble jack contact onto cable as shown. Jack contact should butt against cable dielectric during attachment.
Solder Attachment: Solder jack contact to center conductor through solder hole using .020 (.051) diameter flux core solder wire. Use a minimum amount of solder for a good joint.
Crimp Attachment: Crimp jack contact to center conductor using Johnson ergonomic hand crimp frame 140-0000-967 with recommended hex size die set. Crimp location should be on end of jack contact next to cable dielectric. Crimp attachment to solid center conductor cables is not recommended.
4. Flare braid and slide bulkhead jack connector assembly over jack contact and under braid. Seat bulkhead jack connector assembly firmly onto contact. Arrange braid uniformly around crimp stem. Slide crimp sleeve forward and crimp using Johnson ergonomic hand crimp frame 140-0000-967 with recommended hex size die set. Maintain forward pressure on cable while crimping.

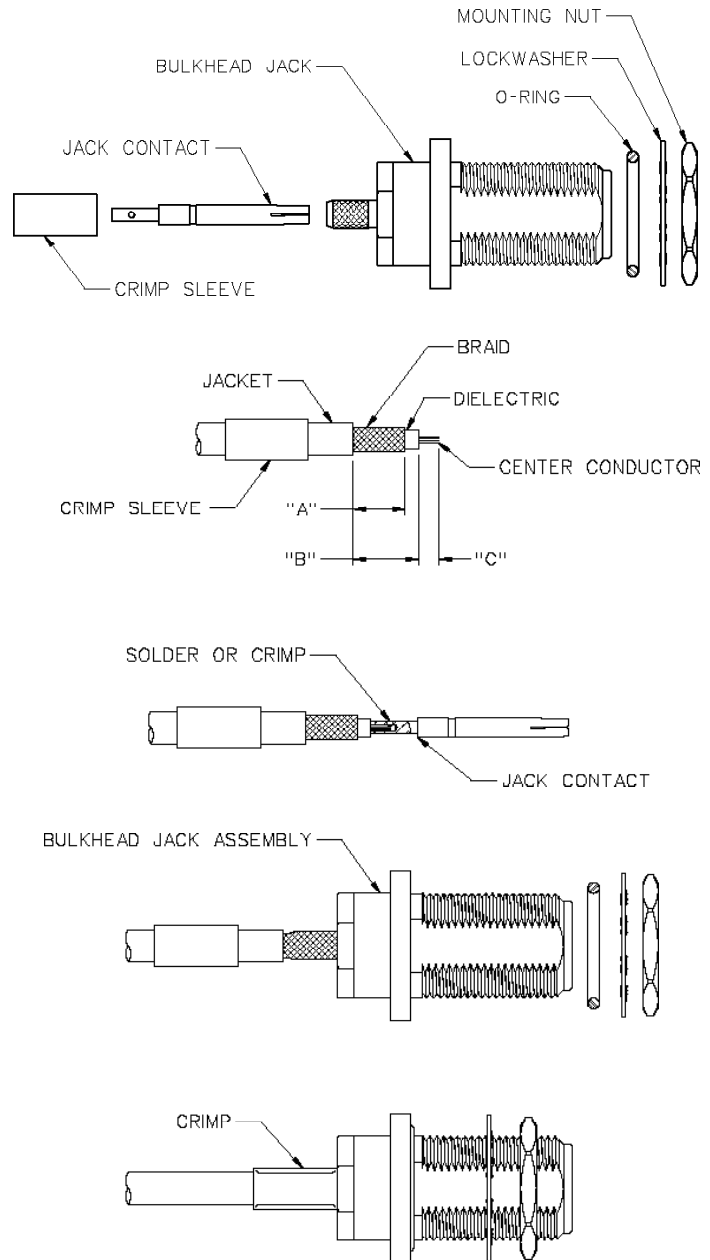

Cable Group	Part No.	"A"	"B"	Crimp Sleeve "C"	Contact Hex Size	Hex Size
RG-58/U, 141, 303	138-4307-407	.310 (7.87)	.389 (9.88)	.135 (3.43)	.213 (5.41)	.068 (1.73)
RG-55/U, 142, 223, 400	138-4308-407	.310 (7.87)	.389 (9.88)	.135 (3.43)	.213 (5.41)	.068 (1.73)
RG-8, 213	138-4316-407	.385 (9.78)	.400 (10.16)	.165 (4.19)	.429 (10.90)	.111 (2.82)
RG-9, 214	138-4318-407	.385 (9.78)	.400 (10.16)	.165 (4.19)	.429 (10.90)	.111 (2.82)

Assembly		
Tool	138-4307/4308-407	138-4316/4318/4349-407
Crimp Frame	140-0000-967	140-0000-967
Die Set	140-0000-990	140-0000-991

For more information, please contact customer service at (507) 833-8822 or (800) 247-8256 • cinch.com

Illustrations are shown in inches (millimeters).

Crimp Type Straight Cable Termination for Flexible Cable

1. Identify connector parts. (2 piece parts)
2. Strip cable to dimensions shown. Do not nick braid or center conductor. A wire stripper of correct size is recommended for this step. Twist stranded center conductor into tight bundle and tin. Slide crimp sleeve onto cable as shown.
3. Flare braid and slide cable into body making certain that the cable insulation is flush with bottom of connector.
4. Arrange braid uniformly around crimp stem. Slide crimp sleeve over braid and crimp securely using recommended crimp tool.

Cable Group	Part No.	"A"	Crimp Hex
RG-178/U, 196	142-0002-221/226	.259 (6.58)	.105 (2.67)
RG-316/U, 161, 174, 179, 187, 188	142-0003-201/206	.312 (7.92)	.128 (3.25)
	142-0003-231/236	.259 (6.58)	.128 (3.25)
	142-0003-241/246	.259 (6.58)	.128 (3.25)
RG-316 DS, 188 DS	142-0004-201/206	.312 (7.92)	.151 (3.83)
	142-0004-211/216	.259 (6.58)	.151 (3.83)
	142-0004-221/226	.259 (6.58)	.151 (3.83)

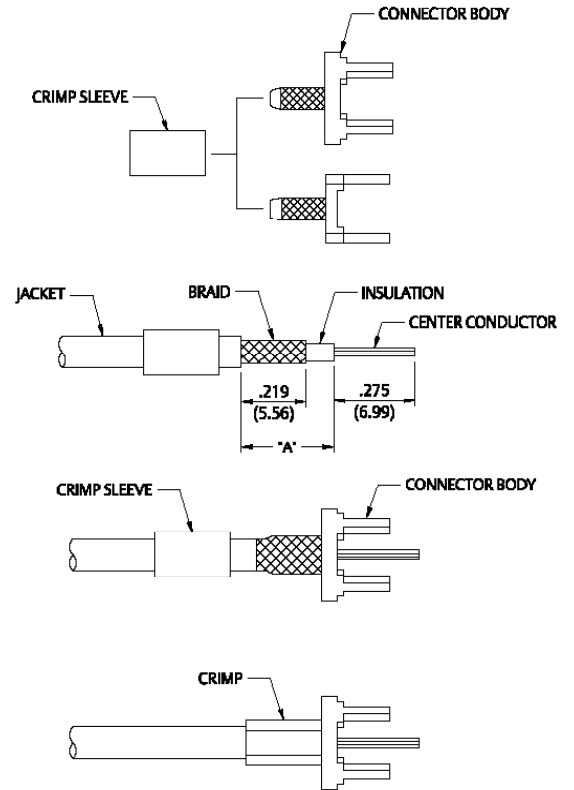

Crimp Type Right Angle Cable Termination for Flexible Cable

1. Identify connector parts. (2 piece parts)
2. Strip cable to dimensions shown. Do not nick braid or center conductor. A wire stripper of correct size is recommended for this step. Twist stranded center conductor into tight bundle and tin. Slide crimp sleeve onto cable as shown.
3. Flare braid and slide cable into body making certain that the cable insulation is flush with bottom of connector body.
4. Arrange braid uniformly around crimp stem. Slide crimp sleeve over braid and crimp securely using recommended crimp tool.

Cable Group	Part No.	Crimp Hex
RG-316/U, 161, 174, 179, 187, 188	142-0003-301/306	.128 (3.25)
RG-316 DS, 188 DS	142-0004-301/306	.151 (3.83)

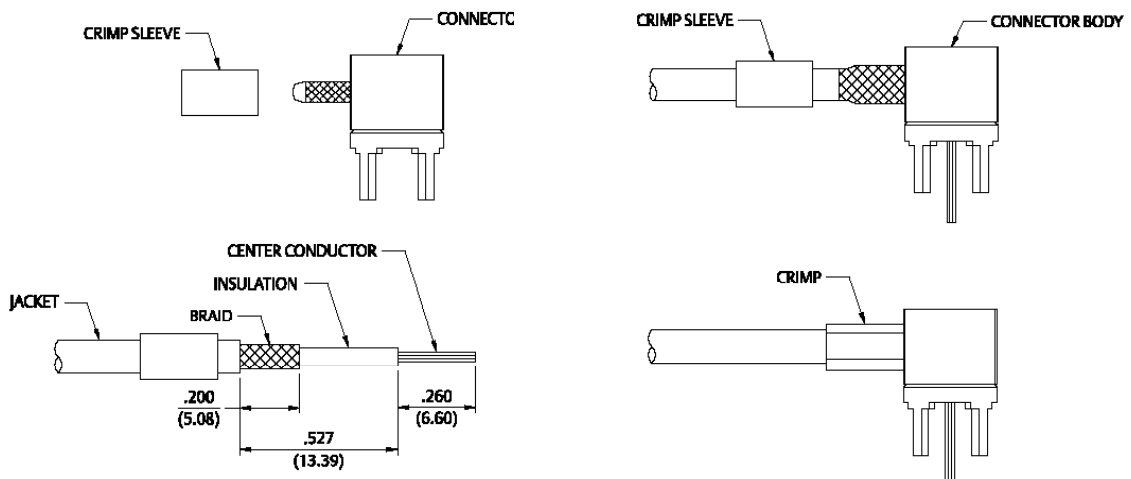

Crimp Type Straight Cable Termination for End Launch

1. Identify connector parts. (2 piece parts)
2. Strip cable to dimensions shown. Do not nick braid or center conductor. A wire stripper of correct size is recommended for this step. Twist stranded center conductor into tight bundle and tin. Slide crimp sleeve onto cable as shown.
3. Flare braid and slide cable into body making certain that the cable insulation is flush with bottom of connector body.
4. Arrange braid uniformly around crimp stem. Slide crimp sleeve over braid and crimp securely using recommended crimp tool.

Cable Group	Part No.	Crimp Hex
RG-178/U, 196	142-0002-811	.105 (2.67)
RG-316/U, 161, 174, 179, 187, 188	142-0003-801 142-0003-811	.128 (3.25) .128 (3.25)
RG-316 DS, 188 DS, 179 DS, 187 DS	142-0004-801 142-0004-811	.151 (3.84) .151 (3.84)
RG-58/U, 141, 303	142-0007-801 142-0007-811	.213 (5.41) .213 (5.41)
RG-142/U, 55, 223, 400	142-0008-801 142-0008-811	.213 (5.41) .213 (5.41)

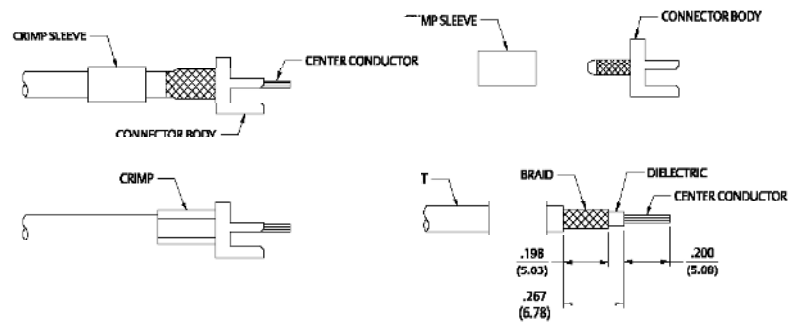

Solder Type Straight Cable Termination for End Launch

1. Identify connector parts. (1 piece part)
2. Strip cable to dimensions shown. Do not nick braid or center conductor.
3. Insert cable into body making sure cable is bottomed against shoulder body. Solder body to cable. Use a minimum amount of heat to minimize cable dielectric movement.

Cable Group	Part No.
RG-405/U (.086 Semi-Rigid)	142-0093-801/806
RG-402/U (.141 Semi-Rigid)	142-0094-801/806
.250 Semi-Rigid	142-0096-801/806

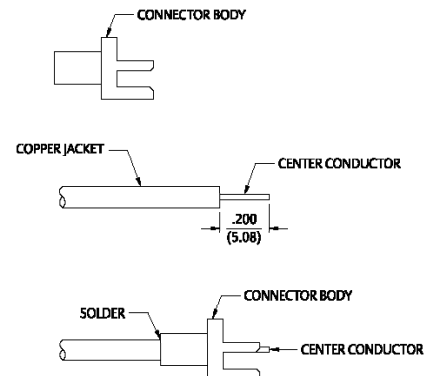

Solder Type Straight Cable Termination for End Launch Surface Mount

1. Identify connector parts. (2-piece parts)
2. Strip cable to dimensions shown. Do not nick braid or center conductor. A wire stripper of correct size is recommended for this step. Twist stranded center conductor into tight bundle and tine. Slide crimp sleeve onto cable as shown.
3. Flare braid and slide cable into body making certain that the cable dielectric is flush with the end of the connector body.
4. Arrange braid uniformly around crimp sleeve. Slide crimp sleeve over braid and crimp securely using recommended crimp tool.

Cable Group	Part No.	Crimp Hex
RG-178/U, 196	142-0002-821	.105 (2.67)

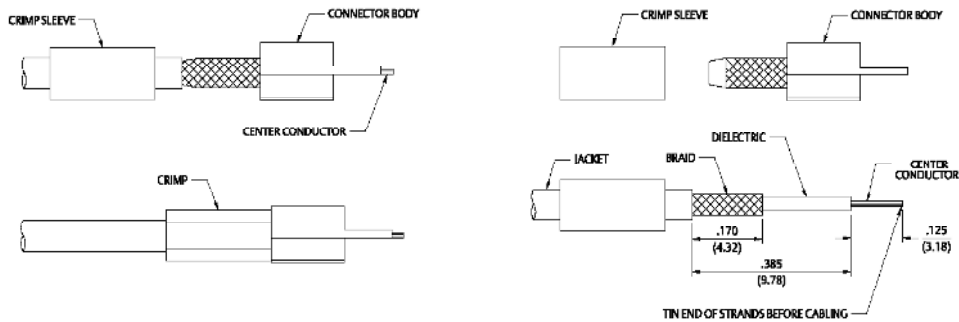

kwiQMate™ Crimp Type Right Angle Plugs for Flexible Cable

1. Identify connector parts. (3 piece parts)
2. Strip cable to dimensions shown. Do not nick braid or center conductor. Twist stranded center conductor into tight bundle and tin (optional). Slide crimp sleeve onto cable as shown.
3. Flare braid and slide cable into body making certain that the cable dielectric bottoms on center contact. Solder center conductor to contact through the rear access port. Use a minimum amount of solder for a full fillet joint. **.020 (0.51) diameter solder is recommended.**
4. Arrange braid uniformly around crimp stem. Slide crimp sleeve over braid and crimp securely using recommended crimp tool. Place expansion cap in access port and seat with .187 (4.75) diameter flat punch. Shrink heat shrink tubing over crimp sleeve if applicable.

Cable Type	Part No.	Crimp Hex
RG-316	146-0403-107	.128 (3.25)
RG-316 DS	146-0404-107	.151 (3.83)

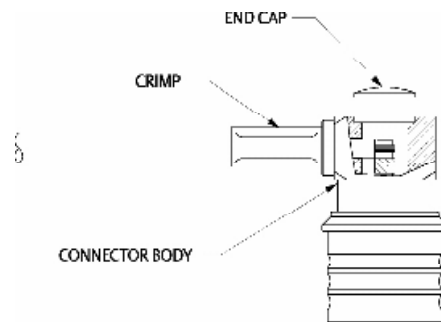
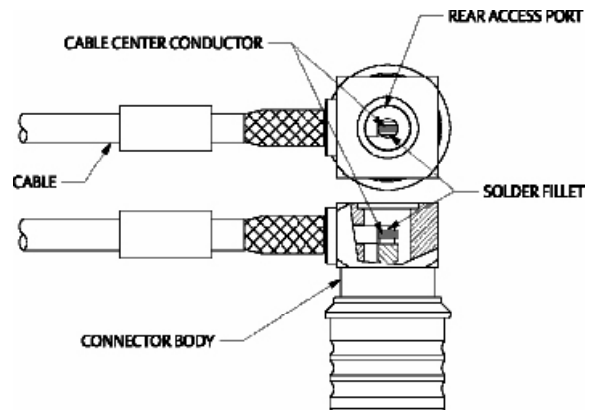
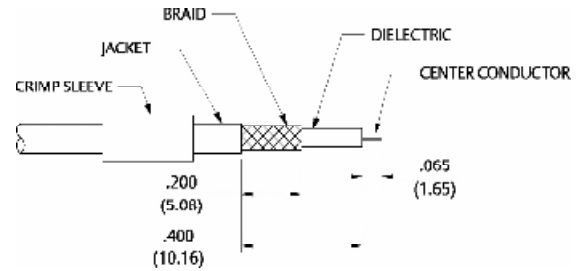
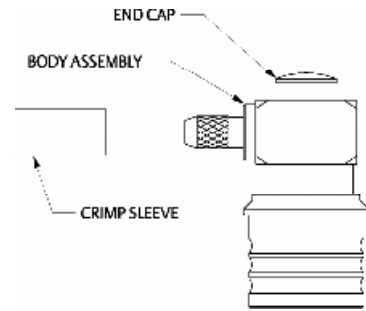

For more information, please contact customer service at (507) 833-8822 or (800) 247-8256 • cinch.com

Illustrations are shown in inches (millimeters).

kwiQMate™ Straight Plugs for Flexible Cable – Crimp or Solder Contacts

1. Identify connector parts. (3 piece parts)
2. Strip cable to dimensions shown. Do not nick braid or center conductor. Tin center conductor if contact will be solder attached. Do not tin center conductor if contact is to be crimp attached. Slide heat shrink (as applicable) and crimp sleeve onto jacket of cable.
3. Assemble contact onto cable as shown.
Solder Attachment: Solder contact to center conductor through solder hole using .020 (0.51) diameter solder. Use a minimum amount of solder for a good joint.
Crimp Attachment: Crimp contact to center conductor using Johnson® Hand Tool 144-0000-910, setting #2. Crimp location should be centered between end of contact and X-hole. Crimp attachment to solid center conductor cables is not recommended.
4. Flare braid and slide body assembly over contact and under braid. Then seat body assembly firmly onto contact. The cable may have to be held in a clamping fixture. Arrange braid uniformly around crimp stem. Slide crimp sleeve forward and crimp using recommended crimp tool. Slide heat shrink forward and shrink (as applicable).

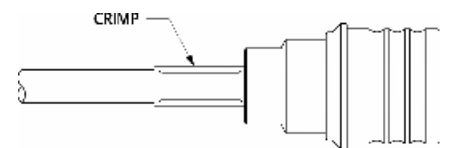
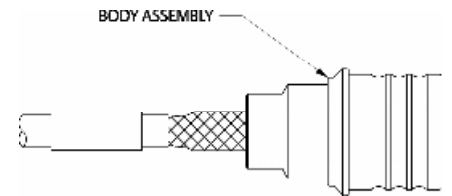
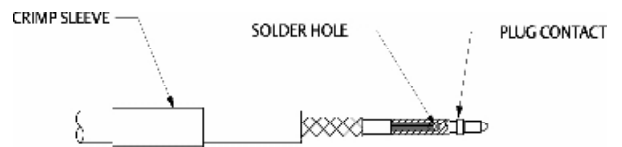
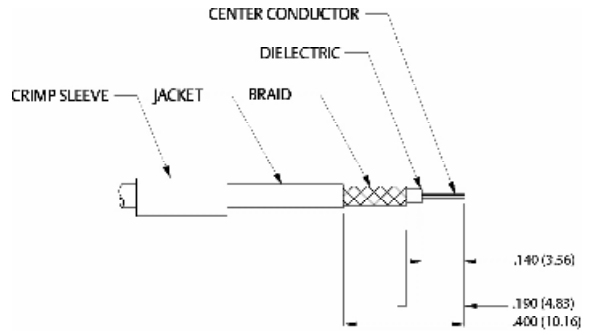
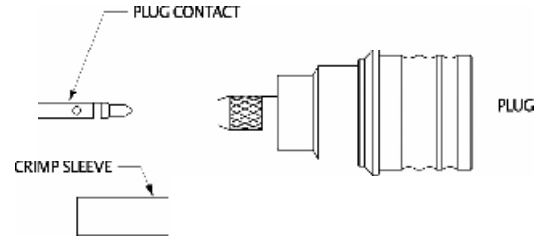

Cable Type	Part No.	Crimp Hex
RG-316	146-0403-007	.128 (3.25)
RG-316 DS	146-0404-007	.151 (3.83)

Electronic Hardware

Other Information	
Assembly Tools	185
Capabilities	190
Cable Information	192
Assembly Instruction	193
Mounting Hole Layouts	194
Numerical Index	274
Competitor Cross Reference	280

3	MMCX Connectors
13	MCX Connectors
39	SMK Connectors
45	SMA Connectors
103	SMB Connectors
131	SMC Connectors
137	SMP Connectors
145	Type N Connectors
153	Shielded Cable Terminations
157	Between-Series Adapters
161	Fixed Length Cable Assemblies
173	Ultra Miniature Connectors (UMC)
181	kwiQMate™ Connectors
185	Tools
193	Assembly Instructions
257	Electronic Hardware
274	Index

While every precaution has been taken to ensure accuracy and completeness herein, Cinch Connectivity Solutions assumes no responsibility, and disclaims all liability for damages resulting from use of this information or for any errors or omissions. Specifications subject to change without notice.

Horizontal Test Jacks – For Test Points

Insulated Miniature



Silver Plating	
Part No.	Color
105-1101-001	White
105-1102-001	Red
105-1103-001	Black
105-1104-001	Green
105-1107-001	Yellow

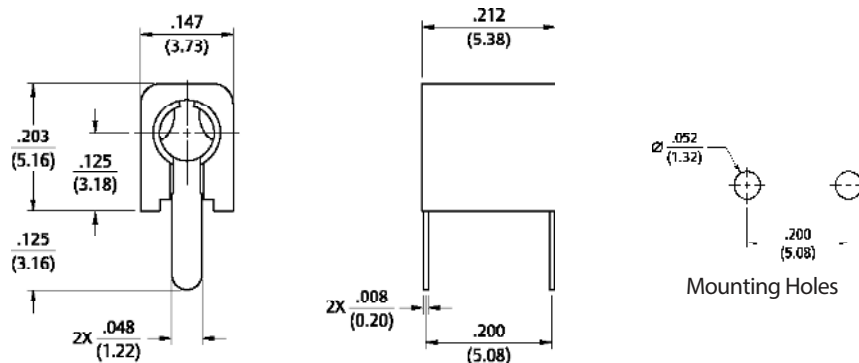

SPECIFICATIONS

Contact: Copper aluminum alloy*

Finish: Silver

Body: Nylon 6/6 per ASTM D4066

RATINGS

Current: 5 amps

Breakdown Voltage: 2100 VRMS minimum

Contact Resistance: 0.010 ohms maximum

Adjacent Jack C: 1 pF maximum at 1 MHz

For Standard Tip Plug:

.080 (2.00) Diameter

FEATURES

- Contact protected from flux and solder
- Probe access from both ends
- Nylon UL approved for self extinguishing

*A new material development that, for this application, meets or exceeds beryllium copper.

Insulated Standard



Silver Plating	
Part No.	Color
105-0751-001	White
105-0752-001	Red
105-0753-001	Black
105-0754-001	Green
105-0756-001	Orange
105-0757-001	Yellow
105-0758-001	Brown
105-0760-001	Blue
105-0762-001	Violet
105-0763-001	Gray

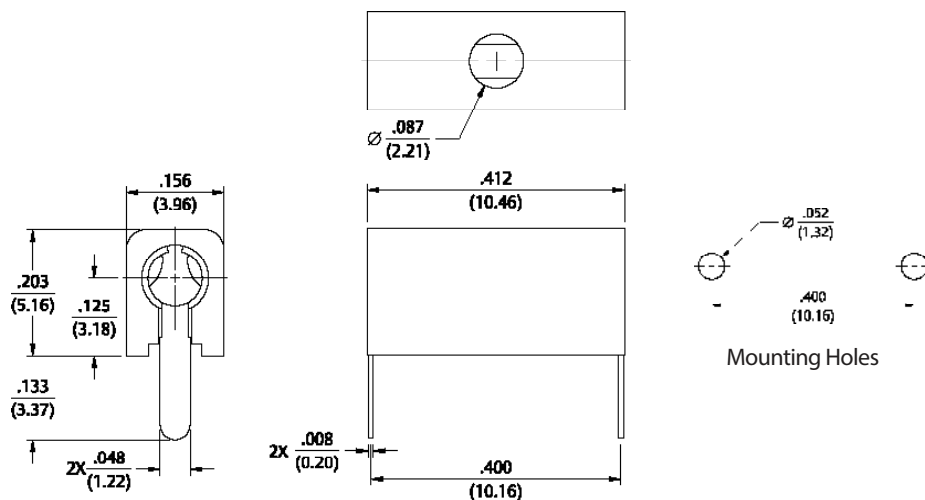

SPECIFICATIONS

Contact: Copper aluminum alloy*

Finish: Silver

Body: Nylon 6/6 per ASTM D4066

RATINGS

Current: 5 amps

Breakdown Voltage: 2100 VRMS minimum

Contact Resistance: Silver: 0.010 ohms maximum

Adjacent Jack C: 1 pF maximum at 1 MHz

For Standard Tip Plug:

.080 (2.00) Diameter

FEATURES

- Contact protected from flux and solder
- Probe access from both ends
- Nylon UL approved for self extinguishing

*A new material development that, for this application, meets or exceeds beryllium copper.

Vertical Test Jacks – For Test Points

Insulated: Formed Contact



Silver Plating	
Part No.	Color
105-2201-201	White
105-2202-201	Red
105-2203-201	Black
105-2204-201	Green
105-2207-201	Yellow

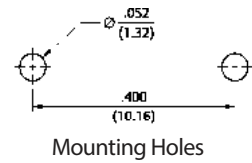
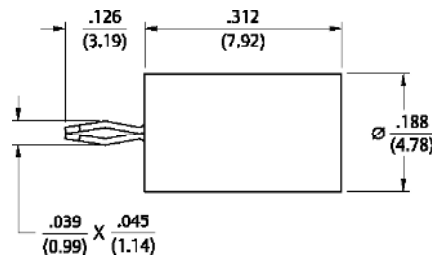

SPECIFICATIONS

Contact: Beryllium copper per QQ-C-533

Finish: Silver

Body: Nylon 6/6 per ASTM D4066

RATINGS

Current: 5 amps

Breakdown Voltage: 3500 VRMS minimum†

Contact Resistance: Silver: 0.010 ohms maximum

Adjacent Jack C: 1 pF maximum at 1 MHz

For Standard Tip Plug:

.080 (2.00) Diameter

FEATURES

- Spring loaded lead to hold in board
- Contact protected from flux and solder
- Nylon UL approved for self extinguishing

† Avoid user injury due to misapplication. See safety advisory definitions inside front cover.

Insulated Standard: Rib-Lock™ Type



Silver Plating	
Part No.	Color
105-1041-001	White
105-1042-001	Red
105-1043-001	Black

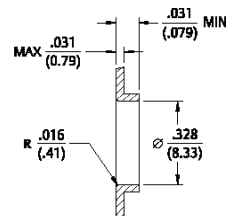
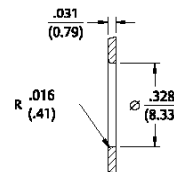
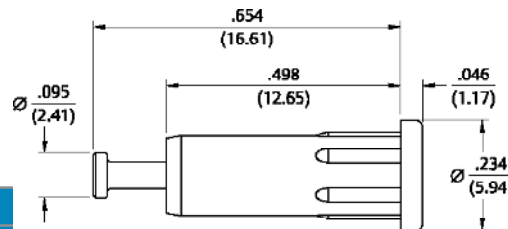

Mounting Holes

SPECIFICATIONS

Contact: Brass body per QQ-B-626D with wrap around beryllium copper spring per QQ-C-553

Finish: Silver

Body: Nylon 6/6 per ASTM D4066

Panel Thickness: up to .375 (9.05)

RATINGS

Current: 5 amps

Breakdown Voltage: 3500 VRMS minimum†

Contact Resistance: 0.005 ohms maximum

Adjacent Jack C: 1 pF nominal

For Standard Tip Plug:

.080 (2.00) Diameter

FEATURES

- Machined contact with turret terminal
- Installs by pressing into mounting hole, no mounting hardware required
- Closed entry blocks access or probes greater than .085 (2.16)
- Nylon UL approved for self extinguishing

† Avoid user injury due to misapplication. See safety advisory definitions inside front cover.

For more information, please contact customer service at (507) 833-8822 or (800) 247-8256 • cinch.com

Illustrations are shown in inches (millimeters).

Tip Jacks – For Connections to Test Equipment, Power Supplies, and Electronic Instrumentation

Insulated Metal Clad: Military Type



Gold Plating Part No. to Mil-Spec. Part No. Cross Reference

Part No.	Color	Mil-C-39024/10
105-0201-200	White	-01
105-0202-200	Red	-02
105-0203-200	Black	-03

SPECIFICATIONS

Contact: Brass per QQ-B-626D with wrap around beryllium copper spring per QQ-C-533

Finish: Gold

Body: Nylon 6/6 per ASTM D4066

Threaded Brass Jacket: Per QQ-B-626D, nickel

Hardware: Nickel plated washer and nut (unassembled)

Panel Thickness: Up to .218 (5.45)

RATINGS

Current: 10 amps

Breakdown Voltage: 5700 VRMS minimum

Contact Resistance: 0.004 ohms maximum

Contact-To-Panel C: 2 pF nominal

Manufactured to meet MIL-C-39024/10

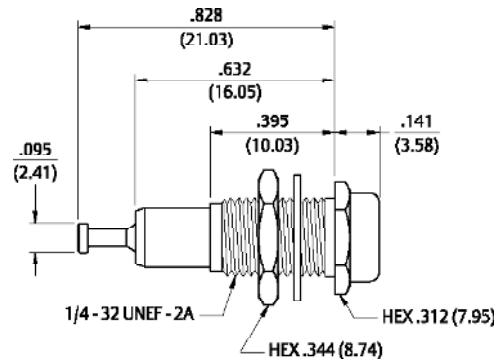

For Standard Tip Plug: .080 (2.00) Diameter FEATURES

- Machined contact with turret terminal
- For military or industrial applications
- Closed entry blocks access of probes greater than .085 (2.16)
- Nylon UL approved for self extinguishing

† Avoid user injury due to misapplication. See safety advisory definitions inside front cover.

Insulated Metal Clad: Standard Type



Silver Plating

Part No.	Color
105-0251-001	White
105-0252-001	Red
105-0253-001	Black

SPECIFICATIONS

Contact: Phosphor bronze per QQ-B-750

Finish: Silver

Body: Nylon 6/6 per ASTM D4066

Panel Thickness: Up to .281 (7.10)

RATINGS

Current: 10 amps

Breakdown Voltage: 5700 VRMS minimum†

Contact Resistance: 0.010 ohms maximum

Contact-To-Panel C: 2 pF nominal

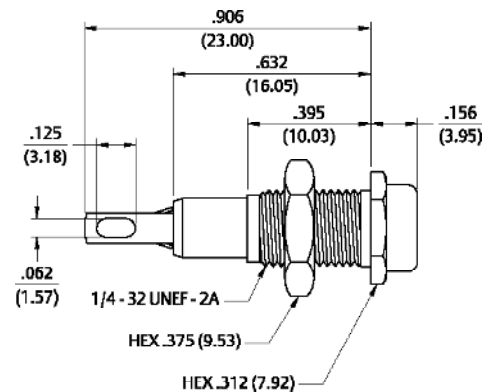

For Standard Tip Plug: .080 (2.00) Diameter FEATURES

- Formed contact with slotted terminal
- Nylon UL approved for self extinguishing

† Avoid user injury due to misapplication. See safety advisory definitions inside front cover.

Tip Jacks – For Connections to Test Equipment, Power Supplies, and Electronic Instrumentation

Insulated Deluxe



Silver Plating	
Part No.	Color
105-0601-001	White
105-0602-001	Red
105-0603-001	Black

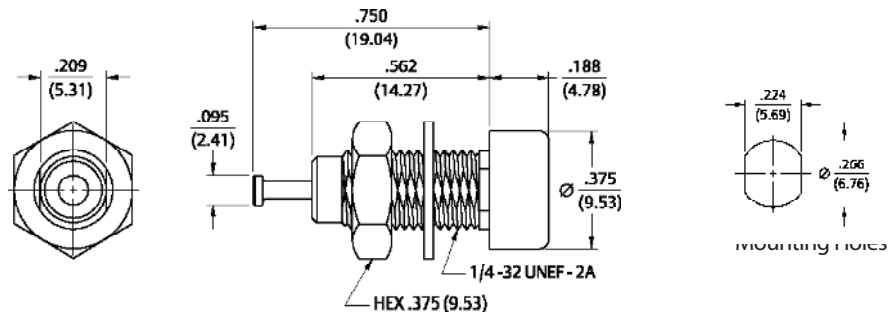

SPECIFICATIONS

Contact: Brass per QQ-B-626D with wrap around beryllium copper spring per QQ-C-533

Finish: Silver

Body: Nylon 6/6 per ASTM D4066

Hardware: Nickel plated nut (unassembled)

Body Thread Stripping Torque: 0.4 lb. in (4.5 kg cm)

Panel Thickness: Up to .437 (11.10)

RATINGS

Current: 10 amps

Breakdown Voltage: 5700 VRMS minimum†

Contact Resistance: 0.010 ohms maximum

Contact-To-Panel C: 2 pF nominal

For Standard Tip Plug: .080 (2.00) Diameter FEATURES

- Machined contact with turret terminal
- Hex socket head .188 (4.77) for ease in mounting
- Closed entry blocks access of probes greater than .085 (2.16)
- Nylon UL approved for self extinguishing

† Avoid user injury due to misapplication. See safety advisory definitions inside front cover.

Insulated Standard



Bright Tin Plating	
Part No.	Color
105-0801-001	White
105-0802-001	Red
105-0803-001	Black
105-0804-001	Green
105-0807-001	Yellow

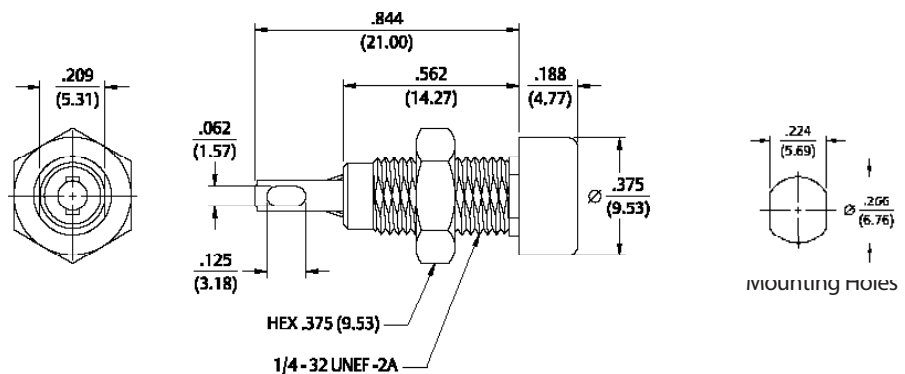

SPECIFICATIONS

Contact: Phosphor bronze per QQ-B-750

Finish: Bright tin

Body: Nylon 6/6 per ASTM D4066

Hardware: Nickel plated nut (unassembled)

Body Thread Stripping Torque: 4.0 lb. in (4.5 kg cm)

Panel Thickness: Up to .437 (11.10)

RATINGS

Current: 10 amps

Breakdown Voltage: 5700 VRMS minimum†

Contact Resistance: 0.010 ohms maximum

Contact-To-Panel C: 2 pF nominal

For Standard Tip Plug: .080 (2.00) Diameter FEATURES

- Formed contact with slotted terminal
- Hex socket head .188 (4.77) for ease in mounting
- Nylon UL approved for self extinguishing

† Avoid user injury due to misapplication. See safety advisory definitions inside front cover.

For more information, please contact customer service at (507) 833-8822 or (800) 247-8256 • cinch.com

Illustrations are shown in inches (millimeters).

Tip Jacks – For Connections to Test Equipment, Power Supplies, and Electronic Instrumentation

Insulated Metal Clad: Military Type



Silver Plating	
Part No.	Color
105-0701-001	White
105-0702-001	Red
105-0703-001	Black

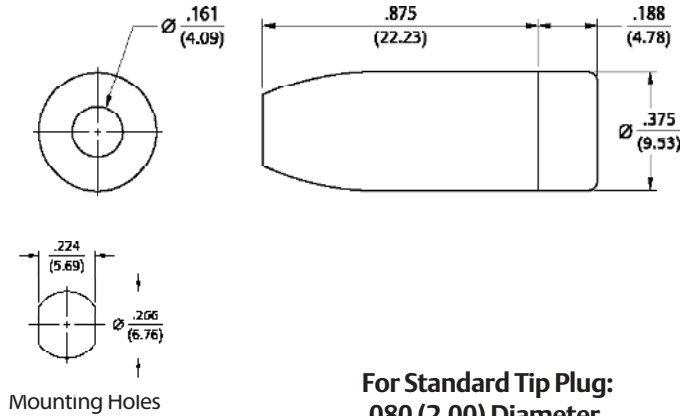

SPECIFICATIONS

Contact: Brass per QQ-B-626D with wrap around beryllium copper spring per QQ-C-533

Finish: Silver

Body: Nylon 6/6 per ASTM D4066

Threaded Brass Jacket: Per QQ-B-626D, nickel

Hardware: Nickel plated washer and nut (unassembled)

Panel Thickness: Up to .218 (5.45)

RATINGS

Current: 10 amps

Breakdown Voltage: 5700 VRMS minimum

Contact Resistance: 0.004 ohms maximum

Contact-To-Panel C: 2 pF nominal

Manufactured to meet MIL-C-39024/10

For Standard Tip Plug: .080 (2.00) Diameter FEATURES

- Machined contact with turret terminal
- For military or industrial applications
- Closed entry blocks access of probes greater than .085 (2.16)
- Nylon UL approved for self extinguishing

† Avoid user injury due to misapplication. See safety advisory definitions inside front cover.

Insulated Metal Clad: Standard Type



Nickel Plating	
Solder Type Up to 16 Gauge Part No.	Crimp Type 16 Gauge Plating Color
105-0771-001	White
105-0772-001	Red
105-0773-001	Black

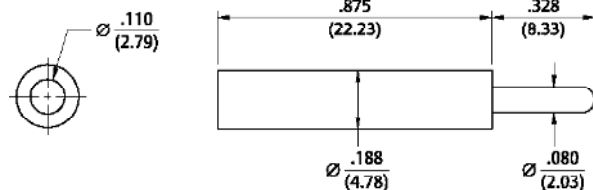

SPECIFICATIONS

Contact: Brass per QQ-B-626D

Finish: Nickel

Insulated Handle: Nylon 6/6 per ASTM D4066

RATINGS

Current: 10 amps

Breakdown Voltage: 3500 VRMS minimum†

Contact Resistance: 0.010 ohms maximum

For Standard Tip Plug: .080 (2.00) Diameter FEATURES

- Solder or crimp type connection
- Accepts wire sizes up to 16 gauge
- Nylon UL approved for self extinguishing
- Designed for use with horizontal and vertical test jacks only

† Avoid user injury due to misapplication. See safety advisory definitions inside front cover.

Tip Plugs & Banana Jacks – For Connections to Monitoring Equipment

Insulated Deluxe



Nickel Plating	
Part No.	Color
105-0301-001	White
105-0302-001	Red
105-0303-001	Black
105-0304-001	Green
105-0310-001	Blue

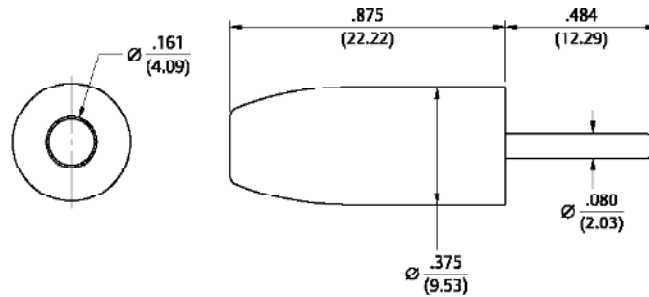

SPECIFICATIONS

Contact: Brass per QQ-B-626D

Finish: Nickel

Insulated Handle: Nylon 6/6 per ASTM D4066

RATINGS

Current: 10 amps

Breakdown Voltage: 3500 VRMS minimum†

Contact Resistance: 0.010 ohms maximum

For Standard Tip Plug:

.080 (2.00) Diameter

FEATURES

- Recessed head to reduce shock hazard
- Accepts wire sizes up to 16 gauge
- Nylon UL approved for self extinguishing

† Avoid user injury due to misapplication. See safety advisory definitions inside front cover.

Insulated Standard



Nickel Plating	
Part No.	Color
108-0740-001	Nickel

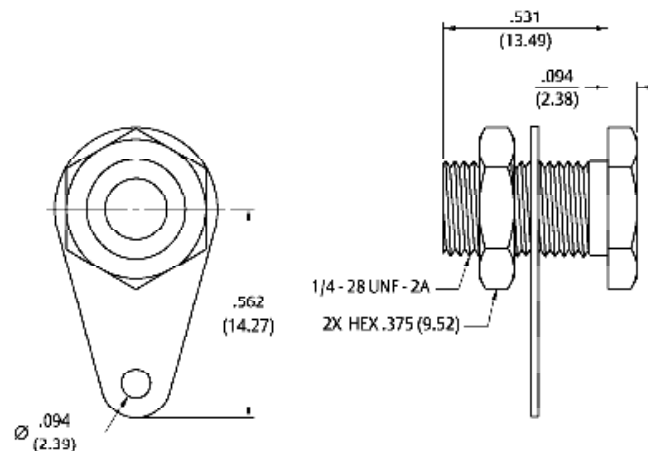

SPECIFICATIONS

Jack Body: Brass per QQ-B-626D

Finish: Nickel

Hardware: Nickel plated nut; stamped tin plated solder terminal (unassembled)

Panel Thickness: Up to .375 (9.50)

RATINGS

Current: 15 amps

Contact Resistance: 0.010 ohms maximum

For Standard Banana Plug:

.175 (4.44) Across Flats

FEATURES

- Accepts up to 12 gauge wire
- Hex head for faster installation
- For higher current designs

For more information, please contact customer service at (507) 833-8822 or (800) 247-8256 • cinch.com

Illustrations are shown in inches (millimeters).

Banana Jacks – For Test Equipment and Power Supplies

Uninsulated Standard Type: Slotted Lug Terminal



Nickel Plating	
Part No.	Color
108-0740-102	Nickel

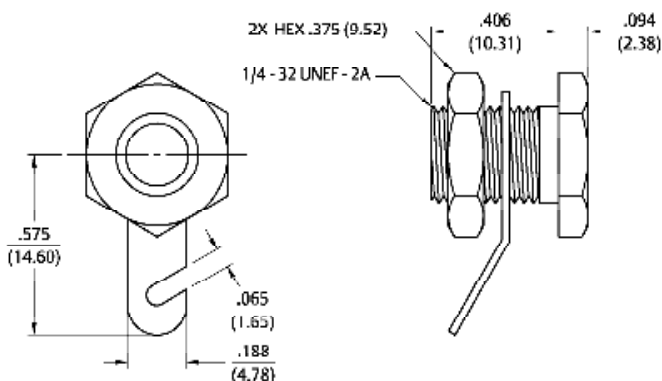

SPECIFICATIONS

Jack Body: Brass per QQ-B-626D
Finish: Nickel
Hardware: Nickel plated nut; stamped tin plated solder terminal (unassembled)
Panel Thickness: Up to .250 (6.35)

RATINGS

Current: 15 amps
Contact Resistance: 0.010 ohms maximum

For Standard Banana Plug:
.175 (4.44) Across Flats

FEATURES

- Accepts up to 12 gauge wire
- Hex head for faster installation
- For higher current designs

Insulated Rib-Loc™ Solder Terminal



Bright Tin Plating	
Part No.	Color
108-2301-801	White
108-2302-801	Red
108-2303-801	Black
108-2307-801	Yellow
108-2310-801	Blue

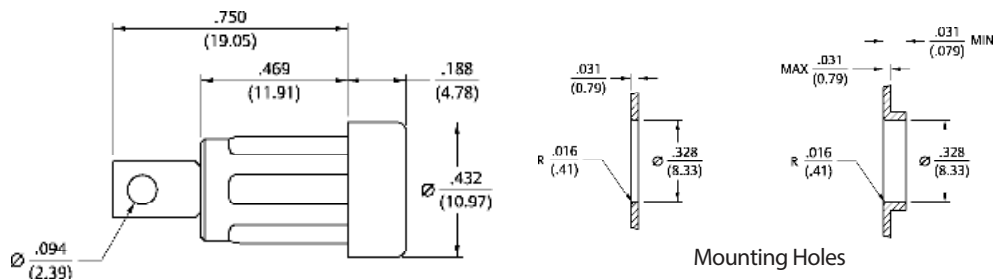

SPECIFICATIONS

Contact: Formed brass per QQ-B-626D
Finish: Bright Tin
Body: Nylon 6/6 per ASTM D4066
Panel Thickness: Up to .250 (6.35)

RATINGS

Current: 15 amps
Breakdown Voltage: 7000 VRMS minimum†
Contact Resistance: 0.010 ohms maximum
Contact-To-Panel C: 2.4 pF nominal

For Standard Banana Plug:

.175 (4.44) Across Flats

FEATURES

- Requires no mounting hardware
- Accepts up to 16 gauge wire
- Nylon UL approved for self extinguishing

† Avoid user injury due to misapplication. See safety advisory definitions inside front cover.

Insulated Turret Terminal



Silver Plating	
Part No.	Color
108-2302-621	Red
108-2303-621	Black

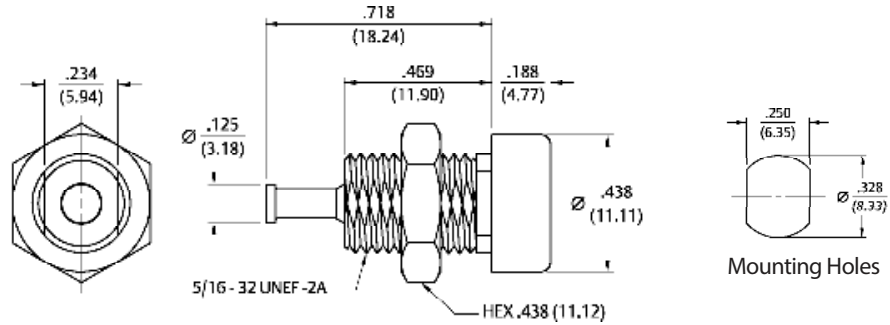

SPECIFICATIONS

Contact: Machined brass per QQ-B-626D
Finish: Silver
Body: Nylon 6/6 per ASTM D4066
Hardware: Nickel plated nut (unassembled)
Body Thread Stripping Torque: 6.0 lb. in. (7 kg cm)
Panel Thickness: Up to .343 (8.80)

For Standard Banana Plug:

.175 (4.44) Across Flat
FEATURES

- Keyed mounting with double flats
- Nylon UL approved for self extinguishing

RATINGS

Current: 15 amps
Breakdown Voltage: 7000 VRMS minimum
Contact Resistance: 0.010 ohms maximum
Contact-To-Panel: 2.4 pF nominal

Insulated Solder Terminal



Bright Tin Plating	
Part No.	Color
108-0901-001	White
108-0902-001	Red
108-0903-001	Black
108-0904-001	Green
108-0906-001	Orange
108-0907-001	Yellow
108-0908-001	Brown
108-0910-001	Blue
108-0912-001	Violet
108-0913-001	Gray

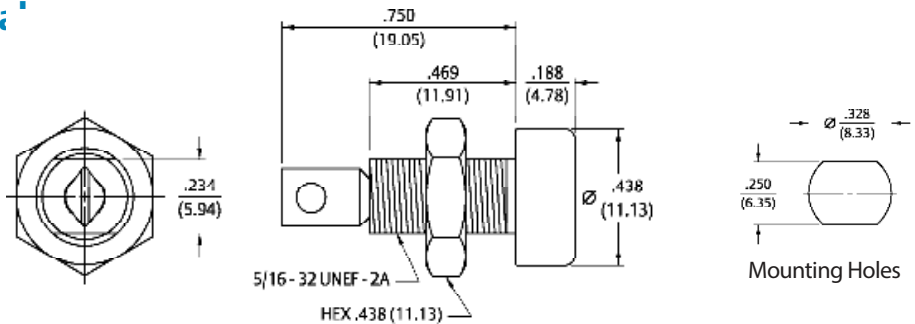

SPECIFICATIONS

Jack Body: Formed brass per QQ-B-626D
Finish: Bright tin
Body: Nylon 6/6 per ASTM D4066
Hardware: Nickel plated nut (unassembled)
Body Thread Stripping Torque: 6.0 lb. in. (7 kg cm)
Panel Thickness: Up to .343 (8.80)

For Standard Banana Plug:

.175 (4.44) Across Flats
FEATURES

- Accepts up to 12 gauge wire
- Hex head for faster installation
- For higher current designs

RATINGS

Current: 15 amps
Breakdown Voltage: 7000 VRMS minimum†
Contact Resistance: 0.010 ohms maximum
Contact-To-Panel: 2.4 pF nominal

† Avoid user injury due to misapplication. See safety advisory definitions inside front cover.

Banana Jacks & Plugs – For Test Equipment and Power Supplies

Insulated Pierced Lug Terminal



Nickel Plating	
Part No.	Color
108-0745-001	Red
108-0745-002	Black

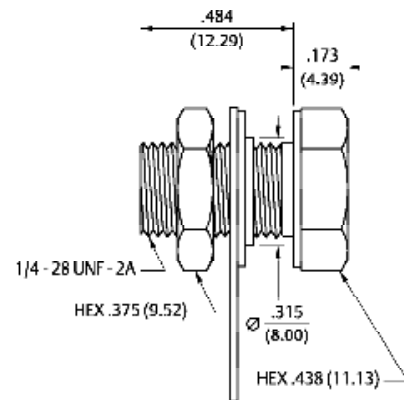
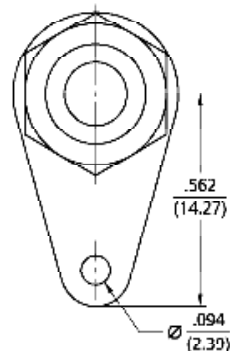

SPECIFICATIONS

Contact:	Brass per QQ-B-626D
Finish:	Nickel
Hex Head:	Molded phenolic
Hardware:	Nickel plated nut, fiber insulating washer and stamped tin plated solder terminal (unassembled)
Panel Thickness:	Up to .281 (7.15)

RATINGS

Current:	15 amps
Breakdown Voltage:	1500 VRMS minimum†
Contact Resistance:	0.010 ohms maximum
Contact-To-Panel:	2.4 pF nominal

For Standard Banana Plug: .175 (4.44) Across Flats

FEATURES

- Withstands extreme temperatures and abuse
- Stamped tin plated solder terminal with hole for up to 12 gauge wire
- Integrally molded hex head for fast installation

† Avoid user injury due to misapplication. See safety advisory definitions inside front cover.

Uninsulated Rivet Type



Silver Plating	
Part No.	Color
108-0754-001	Silver

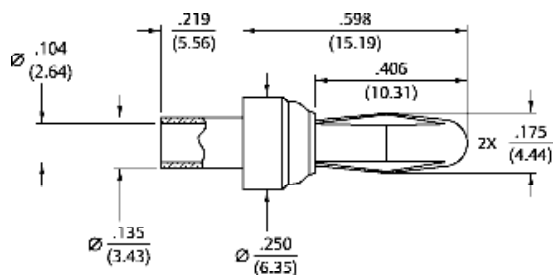

SPECIFICATIONS

Plug Body:	Brass per QQ-B-626D
Plug Spring:	Beryllium copper per QQ-C-533
Finish:	Silver
Panel Thickness:	Up to .156 (4.00)

RATINGS

Current:	15 amps
Contact Resistance:	0.010 ohms maximum

For Standard Banana Plug: .166 (4.23) Diameter

FEATURES

- Shorter spring adapts to standard jack or special size jack
- Ideal for limited space applications

Banana Plugs – For Test Equipment and Power Supplies

Uninsulated Panel Mount Threaded Stud



Nickel Plating	
Part No.	Stud Length "A"
108-0750-001	.375 (9.50)
108-0750-002	.750 (19.05)

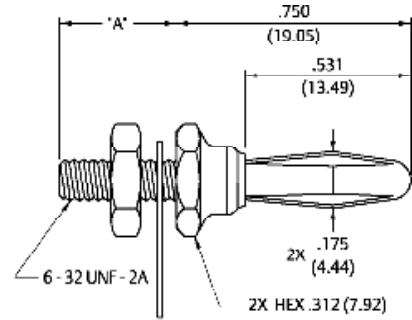
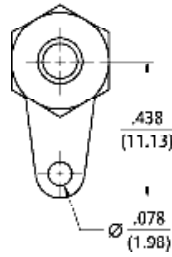

SPECIFICATIONS

- Plug Body:** Brass per QQ-B-626D
- Plug Spring:** Nickel silver per QQ-C-585
- Finish:** Nickel
- Panel Thickness:** Up to .25 (6.35) .625 (16.00)
- Hardware:** Nickel plated nut, stamped tin plated solder terminal (unassembled)

For Standard Banana Plug:

.166 (4.23) Diameter

- FEATURES**
- Pierced hole for up to 14 gauge wires

RATINGS

- Current:** 15 amps
- Contact Resistance:** 0.010 ohms maximum

Uninsulated Panel Mount Screw Type Beryllium Copper Spring



Nickel Plating				
Part No.	Body Length		Panel Thickness	
	A	B	A	B
108-0753-102	906 (32.01)	562 (14.27)	.156 max	.125 max

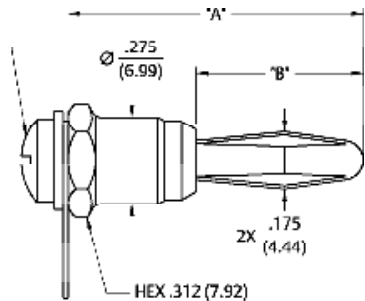
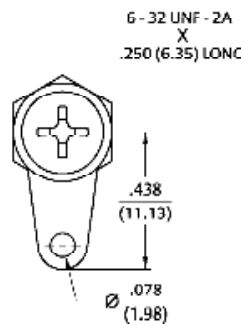

SPECIFICATIONS

- Plug Body:** Brass per QQ-B-626D
- Plug Spring:** Beryllium copper per QQ-C-533
- Finish:** Nickel
- Panel Thickness:** Up to .156 (4.00)
- Hardware:** Nickel plated nut, stamped tin plated solder terminal (unassembled)

For Standard Banana Plug:

.166 (4.23) Diameter

- FEATURES**
- Rugged screw type
 - Stamped tin plated solder terminal with hole for up to 14 gauge wire

RATINGS

- Current:** 15 amps
- Contact Resistance:** 0.010 ohms maximum

For more information, please contact customer service at (507) 833-8822 or (800) 247-8256 • cinch.com

Illustrations are shown in inches (millimeters).

Banana Plugs – For Test Equipment and Power Supplies

Insulated Solderless Tapered Handle



Nickel Plating	
Part No.	Color
108-0301-001	White
108-0302-001	Red
108-0303-001	Black
108-0304-001	Green
108-0306-001	Orange
108-0307-001	Yellow
108-0308-001	Brown
108-0310-001	Blue
108-0312-001	Violet
108-0313-001	Gray

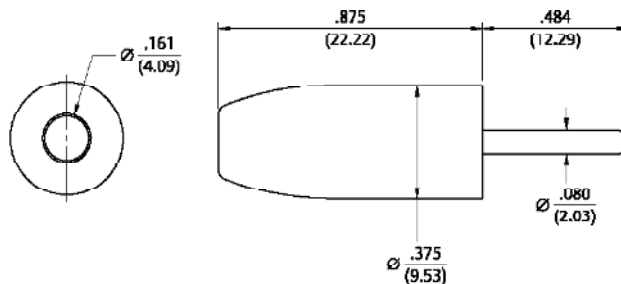

SPECIFICATIONS

Plug Body: Brass per QQ-B-626D
Plug Spring: Nickel silver per QQ-C-533
Finish: Nickel
Insulated Handle: Nylon 6/6 per ASTM D4066

Panel Thickness: Up to .281 (7.15)

RATINGS

Current: 15 amps
Breakdown Voltage: 3500 VRMS minimum†
Contact Resistance: 0.010 ohms maximum

**For Standard Banana Plug:
 .166 (4.23) Diameter**

FEATURES

- Fast solderless connection of up to 16 gauge wire
- Recessed plug body to limit shock hazard
- Nylon UL approved for self extinguishing

† Avoid user injury due to misapplication. See safety advisory definitions inside front cover.

Insulated Side Set Screw Solderless



Nickel Plating	
Part No.	Color
108-1702-101	Red
108-1703-101	Black

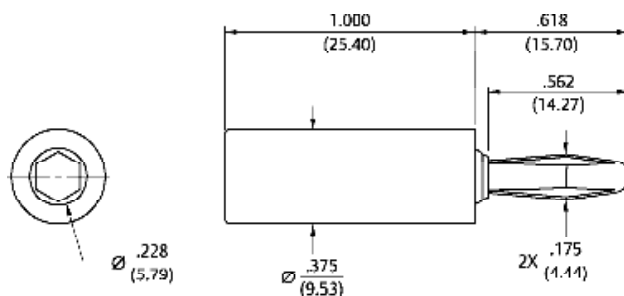

SPECIFICATIONS

Plug Body: Brass per QQ-B-626D
Plug Spring: Nickel silver per QQ-C-585
Finish: Nickel
Insulated Handle: Nylon 6/6 per ASTM D4066

RATINGS

Current: 15 amps
Breakdown Voltage: 35 VRMS minimum†

**For Standard Banana Plug:
 .166 (4.23) Diameter For Low
 Voltage (50 WVDC) Applications**

FEATURES

- Fast solderless connection of up to 16 gauge wire
- Set screw for dependable connections with low voltage
- Nylon UL approved for self extinguishing

† Avoid user injury due to misapplication. See safety advisory definitions inside front cover.

Insulated Hex Body Solder Stud



Nickel Plating	
Part No.	Color
108-1762-101	Red
108-1763-101	Black

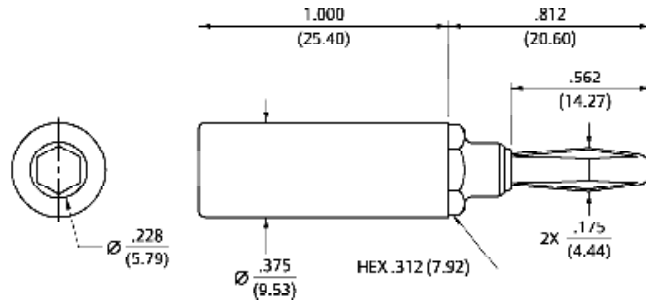

SPECIFICATIONS

Plug Body: Brass per QQ-B-626D
Plug Spring: Nickel silver per QQ-C-585
Finish: Nickel
Insulated Handle: Nylon 6/6 per ASTM D4066

RATINGS

Current: 15 amps
Breakdown Voltage: 3500 VRMS minimum†
Contact Resistance: 0.010 ohms maximum

For Standard Banana Plug: .166 (4.23) Diameter

FEATURES

- Wire can be soldered to threaded stud
- Solder stud accepts up to 16 gauge wire
- Nylon UL approved for self extinguishing

† Avoid user injury due to misapplication. See safety advisory definitions inside front cover.

Insulated Round Body Solder Stud



Nickel Plating	
Part No.	Color
108-1722-101	Red
108-1723-101	Black

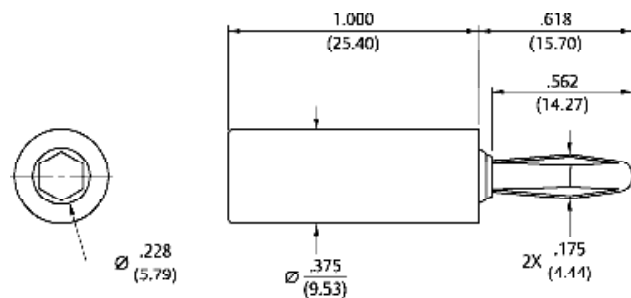

SPECIFICATIONS

Plug Body: Brass per QQ-B-626D
Plug Spring: Nickel silver per QQ-C-585
Finish: Nickel
Insulated Handle: Nylon 6/6 per ASTM D4066

RATINGS

Current: 15 amps
Breakdown Voltage: 3500 VRMS minimum†

For Standard Banana Plug: .166 (4.23) Diameter

FEATURES

- Wire can be soldered to threaded stud
- Solder stud accepts up to 16 gauge wire
- Nylon UL approved for self extinguishing

† Avoid user injury due to misapplication. See safety advisory definitions inside front cover.

Banana Plugs – For Test Equipment and Power Supplies

Insulated Stacking Single Type



Nickel Plating	
Part No.	Color
108-1081-001	White
108-1082-001	Red
108-1083-001	Black
108-1087-001	Yellow

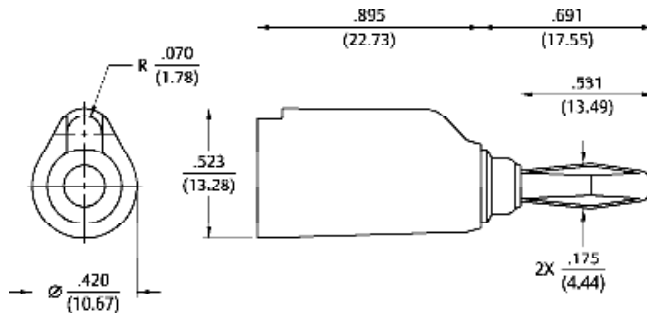

SPECIFICATIONS

Plug Body: Brass per QQ-B-626D
Plug Spring: Nickel silver per QQ-C-585
Finish: Nickel
Insulated Handle: Nylon 6/6 per ASTM D4066

Panel Thickness: Up to .281 (7.15)

RATINGS

Current: 15 amps
Breakdown Voltage: 3500 VRMS minimum†
Contact Resistance: 0.010 ohms maximum

For Standard Banana Plug:

.166 (4.23) Diameter

FEATURES

- Wire can be soldered to threaded stud
- Solder stud accepts up to 16 gauge wire
- Nylon UL approved for self extinguishing

† Avoid user injury due to misapplication. See safety advisory definitions inside front cover.

Insulated Stacking Dual Type



Nickel Plating Set Screw (Accepts Wire Sizes Up To 14 Gauge)	
Part No.	Color
108-0252-001	Red
108-0253-001	Black

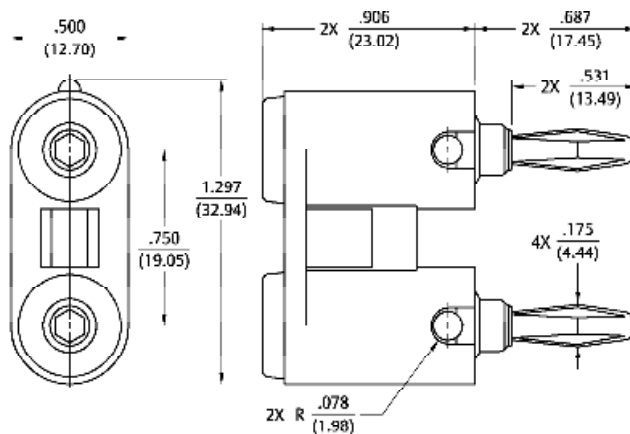

SPECIFICATIONS

Plug Body: Brass per QQ-B-626D
Plug Spring: Nickel silver per QQ-C-586
Finish: Nickel
Insulated Handle: Nylon 6/6 per ASTM D4066

RATINGS

Current: 15 amps
Breakdown Voltage: 3500 VRMS minimum†
Contact Resistance: 0.010 ohms maximum

For Standard Banana Plug:

.166 (4.23) Diameter

FEATURES

- Accepts standard banana plug from rear
- Built-in strain relief for long life
- Nylon UL approved for self extinguishing

† Avoid user injury due to misapplication. See safety advisory definitions inside front cover.

Banana Plugs – For Audio Circuitry and RF Circuitry

Insulated Solder Type



Nickel Plating	
Part No.	Color
108-1002-001	Red
108-1003-001	Black

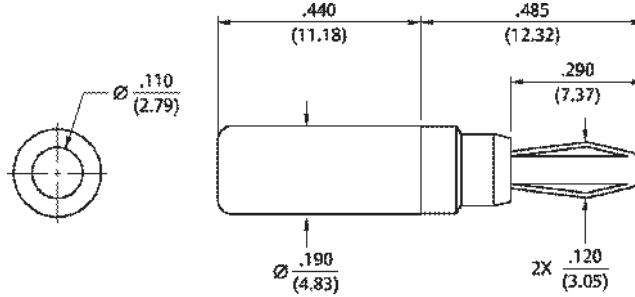

SPECIFICATIONS

Plug Body: Brass per QQ-B-626D
Plug Spring: Beryllium copper per QQ-C-533
Finish: Nickel
Insulated Handle: Nylon 6/6 per ASTM D4066

RATINGS

Current: 10 amps
Breakdown Voltage: 3500 VRMS minimum†
Contact Resistance: 0.010 ohms maximum

For Miniature Banana Jack:
.104 (2.64) Diameter

FEATURES

- Wire can be soldered to threaded stud
- Solder stud accepts up to 16 gauge wire
- Nylon UL approved for self extinguishing

† Avoid user injury due to misapplication. See safety advisory definitions inside front cover.

Uninsulated With Knurled Thumb-Nut-Grounded Type



Nickel Plating	
Part No.	Color
111-2223-001	Nickel

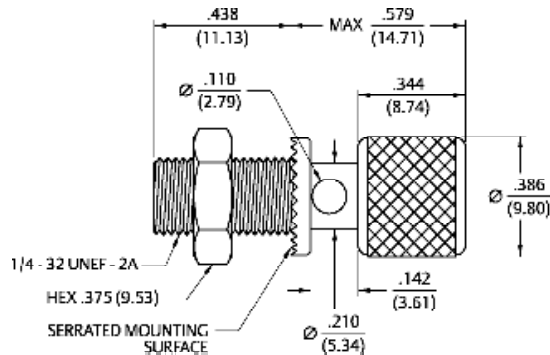

SPECIFICATIONS

Stud: Brass per QQ-B-626D
Finish: Nickel
Hardware: Nickel plated nut (unassembled)
Panel Thickness: Up to .281 (7.15)

RATINGS

Current: 15 amps

For Standard Banana Plug:
.175 (4.44) Across Flats

FEATURES

- Nickel plated stud with serrated mounting surface prevents turning
- Captive thumb nut .110 (2.79) diameter cross-hole accommodates up to 10 gauge wire

Binding Posts – For Audio Circuitry and RF Circuitry

Insulated Standard



Silver Plating	
Part No.	Color
111-0101-001	White
111-0102-001	Red
111-0104-001	Green
111-0103-001	Black
111-0107-001	Yellow
111-0110-001	Blue

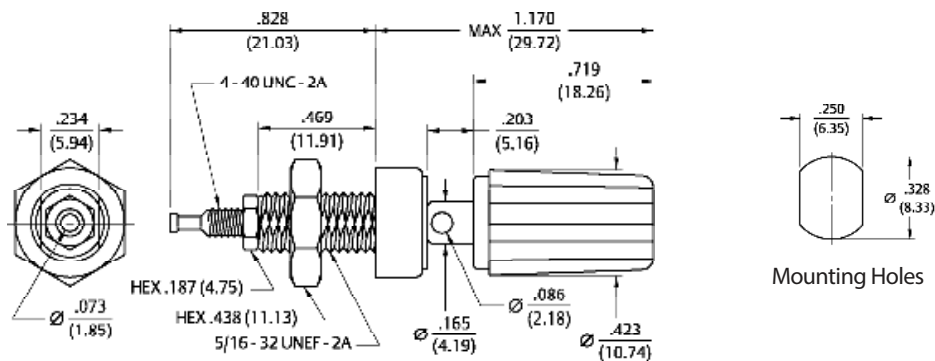

SPECIFICATIONS

Stud: Brass per QQ-B-626D
Finish: Silver
Insulating Material: Nylon 6/6 per ASTM D4066
Hardware: Nickel plated nut (unassembled)
Body Thread Stripping Torque: 6.0 lb. in. (7.0 kg cm)
Panel Thickness: Up to .281 (7.15)

RATINGS

Current: 15 amps
Contact Resistance: 0.010 ohms maximum
Breakdown Voltage: 5700 VRMS minimum†
Stud-To-Panel: 3.3 pF nominal

For Standard Banana Plug:

.175 (4.44) Diameter

FEATURES

- Turret terminal
- Captive thumb nut
- Insulated body is flatted to prevent turning
- Nylon UL approved for self-extinguishing

† Avoid user injury due to misapplication. See safety advisory definitions inside front cover.

Insulated Standard With – Thumb Nut – Grounded Type



Nickel Plating	
Part No.	Color
111-0702-001	Red
111-0703-001	Black

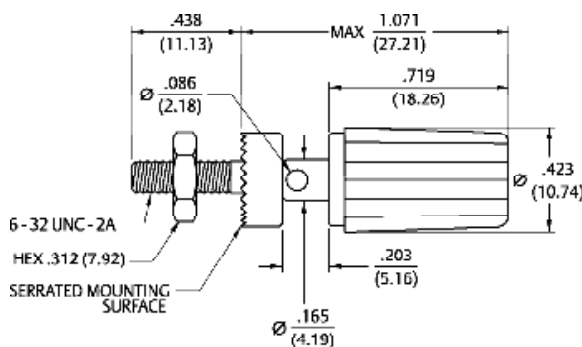

SPECIFICATIONS

Stud: Brass per QQ-B-626D
Finish: Nickel
Insulating Material: Nylon 6/6 per ASTM D4066
Hardware: Nickel plated nut (unassembled)
Panel Thickness: Up to .313 (7.95)

RATINGS

Current: 15 amps

For Standard Banana Plug:

.166 (4.23) Diameter

FEATURES

- Accepts standard banana plug from rear
- Built-in strain relief for long life
- Nylon UL approved for self-extinguishing

† Avoid user injury due to misapplication. See safety advisory definitions inside front cover.

Assembly Tools and Fixtures (108-108X-001 Series)

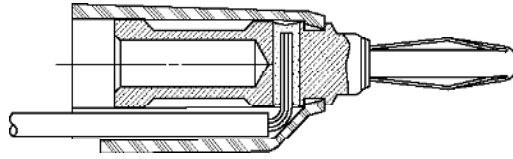

Fixture Part No.	Tool Part No.
251-0111-003	251-0115-002

For Standard Stacking Banana Plugs: .175 (4.44) Across Flats

Quick and easy assembly of standard banana plug .175 (4.44) diameter is possible with the assembly tool and fixtures shown here. Strip wire jacket back 3/4" and feed wire through cross hole of metal contact. Fold stripped wire against metal plug body and slide insulated handle over banana plug body and wires. Insert contact wire into housing. Place into fixture. Push tip of tool into rear of contact. Snap contact into place. Handle of tool is curved to fit hand comfortably. Fixture and tip of tool made from tool steel.

Crimp Tool (105-077X-XXX Series)



Tool Part No.	MIL Part No.
144-0000-910	M22520/1-01

For Insulated Standard Small Handle Tip Plugs: .080 (2.00) Diameter and .060 (1.50) Tip Jacks

Quick and easy assembly of standard banana plug .175 (4.44) diameter is possible with the assembly tool and fixtures shown here. Strip wire jacket back 3/4" and feed wire through cross hole of metal contact. Fold stripped wire against metal plug body and slide insulated handle over banana plug body and wires. Insert contact wire into housing. Place into fixture. Push tip of tool into rear of contact. Snap contact into place. Handle of tool is curved to fit hand comfortably. Fixture and tip of tool made from tool steel.

Table of Contents

Part Number and Competitor Cross-Reference Index

Other Information	
Assembly Tools	185
Capabilities	190
Cable Information	192
Assembly Instruction	193
Mounting Hole Layouts	194
Numerical Index	274
Competitor Cross Reference	280

3	MMCX Connectors
13	MCX Connectors
39	SMK Connectors
45	SMA Connectors
103	SMB Connectors
131	SMC Connectors
137	SMP Connectors
145	Type N Connectors
153	Shielded Cable Terminations
157	Between-Series Adapters
161	Fixed Length Cable Assemblies
173	Ultra Miniature Connectors (UMC)
181	kwiQMate™ Connectors
185	Tools
193	Assembly Instructions
257	Electronic Hardware
274	Index

While every precaution has been taken to ensure accuracy and completeness herein, Cinch Connectivity Solutions assumes no responsibility, and disclaims all liability for damages resulting from use of this information or for any errors or omissions. Specifications subject to change without notice.

105-0201-200.....	260	108-2301-801.....	264	131-3303-501.....	239	131-3701-301.....	113	131-6701-406.....	136
105-0202-200.....	260	108-2302-621.....	265	131-3303-506.....	110	131-3701-306.....	113	131-6701-411.....	136
105-0203-200.....	260	108-2302-801.....	264	131-3303-506.....	239	131-3701-341.....	114	131-6701-416.....	136
105-0251-001.....	260	108-2303-621.....	265	131-3304-401.....	110	131-3701-346.....	114	131-6701-831.....	136
105-0252-001.....	260	108-2303-801.....	264	131-3304-401.....	238	131-3701-401.....	115	131-6701-836.....	136
105-0253-001.....	260	108-2307-801.....	264	131-3304-406.....	110	131-3701-406.....	115	131-6711-201.....	135
105-0301-001.....	263	108-2310-801.....	264	131-3304-406.....	238	131-3701-411.....	115	131-8303-401.....	123
105-0302-001.....	263	111-0101-001.....	272	131-3304-501.....	110	131-3701-416.....	115	131-8303-401.....	238
105-0303-001.....	263	111-0102-001.....	272	131-3304-501.....	239	131-3701-441.....	115	131-8303-406.....	123
105-0304-001.....	263	111-0103-001.....	272	131-3304-506.....	110	131-3701-446.....	115	131-8303-406.....	238
105-0310-001.....	263	111-0104-001.....	272	131-3304-506.....	239	131-3701-501.....	114	131-8304-401.....	123
105-0601-001.....	261	111-0107-001.....	272	131-3402-001.....	108	131-3701-506.....	114	131-8304-401.....	238
105-0602-001.....	261	111-0110-001.....	272	131-3402-001.....	238	131-3701-511.....	114	131-8304-406.....	123
105-0603-001.....	261	111-0702-001.....	272	131-3402-016.....	108	131-3701-516.....	114	131-8304-406.....	238
105-0701-001.....	262	111-0703-001.....	272	131-3402-016.....	238	131-3701-621.....	115	131-8403-001.....	123
105-0702-001.....	262	111-2223-001.....	271	131-3402-101.....	109	131-3701-626.....	115	131-8403-001.....	238
105-0703-001.....	262	127-0692-001.....	142	131-3402-101.....	239	131-3701-631.....	115	131-8403-006.....	123
105-0751-001.....	258	127-0692-101.....	142	131-3402-116.....	109	131-3701-636.....	115	131-8403-006.....	238
105-0752-001.....	258	127-0693-001.....	142	131-3402-116.....	239	131-3701-801.....	114	131-8403-011.....	123
105-0753-001.....	258	127-0693-101.....	142	131-3403-001.....	108	131-3701-806.....	114	131-8403-011.....	238
105-0754-001.....	258	127-0701-201.....	142	131-3403-001.....	238	131-3701-811.....	114	131-8403-016.....	123
105-0756-001.....	258	127-0701-602.....	143	131-3403-016.....	108	131-3701-816.....	114	131-8403-016.....	238
105-0757-001.....	258	127-0701-612.....	144	131-3403-016.....	238	131-3701-821.....	114	131-8403-101.....	124
105-0758-001.....	258	127-0701-801.....	143	131-3403-021.....	108	131-3701-826.....	114	131-8403-101.....	239
105-0760-001.....	258	127-0701-802.....	143	131-3403-021.....	232	131-3701-831.....	114	131-8403-106.....	124
105-0762-001.....	258	127-0711-601.....	144	131-3403-026.....	108	131-3701-836.....	114	131-8403-106.....	239
105-0763-001.....	258	127-0901-801.....	144	131-3403-026.....	232	131-3711-201.....	113	131-8403-111.....	124
105-0771-001.....	262	127-0901-811.....	144	131-3403-101.....	109	131-3711-301.....	114	131-8403-111.....	239
105-0772-001.....	262	127-0901-821.....	144	131-3403-101.....	239	131-3711-302.....	114	131-8403-116.....	124
105-0773-001.....	262	127-1701-201.....	142	131-3403-116.....	109	131-3801-201.....	111	131-8403-116.....	239
105-0801-001.....	261	127-1701-602.....	143	131-3403-116.....	239	131-3801-216.....	111	131-8404-001.....	123
105-0802-001.....	261	127-1701-612.....	144	131-3403-401.....	108	131-3801-231.....	111	131-8404-001.....	238
105-0803-001.....	261	127-1701-801.....	143	131-3403-401.....	238	131-3801-236.....	111	131-8404-006.....	123
105-0804-001.....	261	127-1701-802.....	143	131-3403-406.....	108	131-3801-301.....	111	131-8404-006.....	238
105-0807-001.....	261	127-1711-601.....	144	131-3403-406.....	238	131-3801-316.....	111	131-8404-011.....	123
105-1041-001.....	259	127-1901-822.....	144	131-3404-001.....	108	131-3801-811.....	116	131-8404-011.....	238
105-1042-001.....	259	127-2701-201.....	142	131-3404-001.....	238	131-3801-816.....	116	131-8404-016.....	123
105-1043-001.....	259	127-2701-602.....	143	131-3404-016.....	108	131-3801-821.....	116	131-8404-016.....	238
105-1101-001.....	258	127-2701-612.....	144	131-3404-016.....	238	131-3801-826.....	116	131-8404-101.....	124
105-1102-001.....	258	127-2701-801.....	143	131-3404-021.....	108	131-3901-401.....	116	131-8404-101.....	239
105-1103-001.....	258	127-2701-802.....	143	131-3404-021.....	232	131-3901-406.....	116	131-8404-106.....	124
105-1104-001.....	258	127-2711-601.....	144	131-3404-026.....	108	131-3901-411.....	116	131-8404-106.....	239
105-1107-001.....	258	127-2901-821.....	144	131-3404-026.....	232	131-3901-416.....	116	131-8404-111.....	124
105-2201-201.....	259	127-3701-201.....	142	131-3404-101.....	109	131-6303-401.....	134	131-8404-111.....	239
105-2202-201.....	259	127-3701-602.....	143	131-3404-101.....	239	131-6303-401.....	238	131-8404-116.....	124
105-2203-201.....	259	128-0000-901.....	180	131-3404-116.....	109	131-6303-406.....	134	131-8404-116.....	239
105-2204-201.....	259	128-0711-201.....	179	131-3404-116.....	239	131-6303-406.....	238	131-8409-001.....	123
105-2207-201.....	259	128-0711-202.....	179	131-3404-401.....	108	131-6304-401.....	134	131-8409-001.....	238
108-0252-001.....	270	129-0701-301.....	156	131-3404-401.....	238	131-6304-401.....	238	131-8409-006.....	123
108-0253-001.....	270	129-0701-302.....	156	131-3404-406.....	108	131-6304-406.....	134	131-8409-006.....	238
108-0301-001.....	268	131-1402-101.....	109	131-3404-406.....	238	131-6304-406.....	238	131-8409-101.....	124
108-0302-001.....	268	131-1402-101.....	239	131-3407-001.....	108	131-6333-401.....	134	131-8409-101.....	239
108-0303-001.....	268	131-1402-116.....	109	131-3407-001.....	238	131-6333-401.....	238	131-8409-106.....	124
108-0304-001.....	268	131-1402-116.....	239	131-3407-006.....	108	131-6333-406.....	134	131-8409-106.....	239
108-0306-001.....	268	131-1403-001.....	108	131-3407-006.....	238	131-6333-406.....	238	131-8433-001.....	123
108-0307-001.....	268	131-1403-001.....	238	131-3407-011.....	108	131-6403-001.....	134	131-8433-001.....	232
108-0308-001.....	268	131-1403-016.....	108	131-3407-011.....	232	131-6403-001.....	238	131-8433-006.....	123
108-0310-001.....	268	131-1403-016.....	238	131-3407-016.....	108	131-6403-006.....	134	131-8433-006.....	232
108-0312-001.....	268	131-1403-101.....	109	131-3407-016.....	232	131-6403-006.....	238	131-8434-001.....	123
108-0740-001.....	263	131-1403-101.....	239	131-3407-101.....	109	131-6403-101.....	134	131-8434-001.....	232
108-0740-102.....	264	131-1403-116.....	109	131-3407-101.....	239	131-6403-101.....	239	131-8434-006.....	123
108-0745-001.....	266	131-1403-116.....	239	131-3407-106.....	109	131-6403-106.....	142	131-8434-006.....	232
108-0745-002.....	266	131-1404-001.....	108	131-3407-106.....	239	131-6403-106.....	239	131-8445-001.....	123
108-0750-001.....	267	131-1404-001.....	238	131-3593-401.....	107	131-6404-001.....	134	131-8445-001.....	238
108-0750-002.....	267	131-1404-016.....	108	131-3593-401.....	233	131-6404-001.....	238	131-8445-006.....	123
108-0753-102.....	267	131-1404-016.....	238	131-3593-406.....	107	131-6404-006.....	134	131-8445-006.....	238
108-0754-001.....	266	131-1404-101.....	109	131-3593-406.....	233	131-6404-006.....	238	131-8445-011.....	123
108-0901-001.....	265	131-1404-101.....	239	131-3693-001.....	107	131-6404-101.....	134	131-8445-011.....	232
108-0902-001.....	265	131-1404-116.....	109	131-3693-001.....	233	131-6404-101.....	239	131-8445-016.....	123
108-0903-001.....	265	131-1404-116.....	239	131-3693-016.....	107	131-6404-106.....	134	131-8445-016.....	232
108-0904-001.....	265	131-1693-101.....	234	131-3693-016.....	233	131-6404-106.....	239	131-8445-101.....	124
108-0906-001.....	265	131-1693-116.....	234	131-3693-101.....	107	131-6433-001.....	134	131-8445-101.....	239
108-0907-001.....	265	131-1701-371.....	113	131-3693-101.....	234	131-6433-001.....	238	131-8445-106.....	124
108-0908-001.....	265	131-1701-376.....	113	131-3693-116.....	107	131-6433-006.....	134	131-8445-106.....	239
108-0910-001.....	265	131-1801-371.....	111	131-3693-116.....	234	131-6433-006.....	238	131-8701-201.....	125
108-0912-001.....	265	131-1801-376.....	111	131-3694-401.....	107	131-6433-101.....	134	131-8701-206.....	125
108-0913-001.....	265	131-3302-001.....	110	131-3694-401.....	233	131-6433-101.....	239	131-8701-211.....	125
108-1002-001.....	271	131-3302-001.....	238	131-3694-406.....	107	131-6433-106.....	134	131-8701-216.....	125
108-1003-001.....	271	131-3302-006.....	110	131-3694-406.....	233	131-6433-106.....	239	131-8701-251.....	125
108-1081-001.....	270	131-3302-006.....	238	131-3701-201.....	112	131-6593-401.....	134	131-8701-256.....	125
108-1082-001.....	270	131-3303-001.....	110	131-3701-206.....	112	131-6593-401.....	233	131-8701-261.....	125
108-1083-001.....	270	131-3303-001.....	238	131-3701-211.....	112	131-6593-406.....	134	131-8701-266.....	125
108-1087-001.....	270	131-3303-006.....	110	131-3701-216.....	112	131-6593-406.....	233	131-8701-301.....	126
108-1702-101.....	268	131-3303-006.....	238	131-3701-231.....	112	131-6701-201.....	135	131-8701-306.....	126
108-1703-101.....	268	131-3303-401.....	110	131-3701-236.....	112	131-6701-206.....	135	131-8701-311.....	126
108-1722-101.....	269	131-3303-401.....	238	131-3701-261.....	112	131-6701-211.....	135	131-8701-316.....	126
108-1723-101.....	269	131-3303-406.....	110	131-3701-266.....	112	131-6701-216.....	135	131-8701-501.....	126
108-1762-101.....	269	131-3303-406.....	238	131-3701-271.....	112	131-6701-301.....	135	131-8701-506.....	126
108-1763-101.....	269	131-3303-501.....	110	131-3701-276.....	112	131-6701-401.....	136	131-8701-601.....	127

For more information, please contact customer service at (507) 833-8822 or (800) 247-8256 • cinch.com

Part Number Index

131-8701-606.....	127	133-3433-001.....	207	133-5402-106.....	26	134-1019-371.....	180	138-4403-007.....	150
131-8701-811.....	128	133-3433-006.....	16	133-5402-106.....	210	134-1019-381.....	180	138-4403-007.....	243
131-8701-821.....	128	133-3433-006.....	207	133-5403-001.....	26	134-1068-001.....	34	138-4403-107.....	150
131-8701-841.....	127	133-3433-101.....	17	133-5403-001.....	207	134-1068-011.....	34	138-4403-107.....	245
131-8701-846.....	127	133-3433-101.....	210	133-5403-006.....	26	134-1068-021.....	35	138-4404-007.....	150
131-8711-201.....	126	133-3433-106.....	17	133-5403-006.....	207	134-1068-031.....	35	138-4404-007.....	243
131-8711-202.....	126	133-3433-106.....	210	133-5403-101.....	26	134-1069-001.....	130	138-4404-107.....	150
131-8801-801.....	128	133-3693-001.....	16	133-5403-101.....	210	134-1069-011.....	130	138-4404-107.....	245
131-8801-811.....	128	133-3693-001.....	206	133-5403-106.....	26	134-1069-021.....	130	138-4407-007.....	150
131-8801-821.....	128	133-3693-006.....	16	133-5403-106.....	210	134-1069-031.....	130	138-4407-007.....	244
131-8901-401.....	129	133-3693-006.....	206	133-5404-001.....	26	135-3302-001.....	7	138-4407-107.....	150
131-8901-406.....	129	133-3693-101.....	16	133-5404-001.....	207	135-3302-001.....	205	138-4407-107.....	245
131-8901-801.....	129	133-3693-101.....	206	133-5404-006.....	26	135-3302-401.....	7	138-4408-007.....	150
131-8901-811.....	129	133-3693-106.....	16	133-5404-006.....	207	135-3302-401.....	205	138-4408-007.....	244
131-8901-821.....	129	133-3693-106.....	206	133-5404-101.....	26	135-3303-001.....	7	138-4408-107.....	150
131-9403-001.....	118	133-3701-201.....	18	133-5404-101.....	210	135-3303-001.....	204	138-4408-107.....	245
131-9403-001.....	235	133-3701-206.....	18	133-5404-106.....	26	135-3304-001.....	7	138-4416-007.....	150
131-9403-021.....	118	133-3701-211.....	18	133-5404-106.....	210	135-3304-001.....	204	138-4416-007.....	244
131-9403-021.....	232	133-3701-216.....	18	133-5701-201.....	27	135-3333-001.....	7	138-4416-107.....	150
131-9403-101.....	118	133-3701-221.....	18	133-5701-206.....	27	135-3333-001.....	204	138-4416-107.....	246
131-9403-101.....	237	133-3701-226.....	18	133-5701-801.....	27	135-3336-001.....	7	138-4418-007.....	150
131-9403-101.....	239	133-3701-231.....	19	133-5701-806.....	27	135-3336-001.....	205	138-4418-007.....	244
131-9403-116.....	237	133-3701-236.....	19	133-8333-001.....	31	135-3336-401.....	7	138-4418-107.....	150
131-9403-116.....	239	133-3701-301.....	20	133-8333-001.....	209	135-3336-401.....	205	138-4418-107.....	246
131-9404-001.....	118	133-3701-306.....	20	133-8333-401.....	32	135-3402-001.....	7	138-4449-007.....	150
131-9404-001.....	235	133-3701-311.....	20	133-8333-401.....	209	135-3402-001.....	202	138-4449-007.....	244
131-9404-021.....	118	133-3701-316.....	20	133-8334-001.....	31	135-3402-101.....	6	138-4593-401.....	149
131-9404-021.....	232	133-3701-321.....	20	133-8334-001.....	209	135-3402-101.....	200	138-4593-401.....	251
131-9404-101.....	118	133-3701-326.....	20	133-8334-401.....	32	135-3402-111.....	6	138-4594-401.....	149
131-9404-101.....	237	133-3701-401.....	22	133-8334-401.....	209	135-3402-111.....	201	138-4594-401.....	251
131-9404-101.....	239	133-3701-406.....	22	133-8433-001.....	31	135-3403-001.....	7	138-4596-401.....	149
131-9404-116.....	237	133-3701-411.....	22	133-8433-001.....	209	135-3403-001.....	203	138-4596-401.....	251
131-9404-116.....	239	133-3701-416.....	22	133-8433-101.....	31	135-3403-101.....	6	138-4693-001.....	149
131-9701-201.....	119	133-3701-601.....	22	133-8433-101.....	211	135-3403-101.....	201	138-4693-001.....	247
131-9701-211.....	119	133-3701-606.....	22	133-8434-001.....	31	135-3404-001.....	7	138-4693-011.....	149
131-9701-301.....	119	133-3701-611.....	23	133-8434-001.....	209	135-3404-001.....	203	138-4693-011.....	248
133-3302-001.....	17	133-3701-616.....	23	133-8434-101.....	31	135-3404-101.....	6	138-4694-001.....	149
133-3302-001.....	207	133-3701-621.....	23	133-8434-101.....	211	135-3404-101.....	201	138-4694-001.....	247
133-3302-006.....	17	133-3701-626.....	23	133-8445-001.....	31	135-3433-001.....	7	138-4694-011.....	149
133-3302-006.....	207	133-3701-801.....	21	133-8445-001.....	209	135-3433-001.....	203	138-4694-011.....	248
133-3302-401.....	17	133-3701-806.....	21	133-8445-101.....	31	135-3436-001.....	7	138-4696-001.....	149
133-3302-401.....	207	133-3701-811.....	21	133-8445-101.....	211	135-3436-001.....	202	138-4696-001.....	247
133-3302-406.....	17	133-3701-816.....	21	133-8701-201.....	32	135-3436-101.....	6	138-4696-011.....	149
133-3302-406.....	207	133-3701-821.....	21	133-8701-211.....	32	135-3436-101.....	200	138-4696-011.....	248
133-3303-001.....	17	133-3701-826.....	21	133-8701-301.....	33	135-3693-101.....	6	138-4701-407.....	151
133-3303-001.....	207	133-3711-201.....	19	133-8701-311.....	33	135-3693-101.....	198	138-4701-607.....	151
133-3303-006.....	17	133-3711-202.....	19	133-8701-401.....	33	135-3701-201.....	8	138-4901-407.....	152
133-3303-006.....	207	133-3711-211.....	19	133-8701-801.....	33	135-3701-211.....	8	138-4901-807.....	151
133-3303-401.....	17	133-3711-212.....	19	133-8701-831.....	35	135-3701-301.....	8	138-4901-817.....	152
133-3303-401.....	207	133-3711-301.....	20	133-8711-201.....	32	135-3701-311.....	8	138-9408-007.....	241
133-3303-406.....	17	133-3711-302.....	20	133-8711-211.....	32	135-3711-201.....	8	138-9449-007.....	241
133-3303-406.....	207	133-3711-311.....	20	133-8801-201.....	32	135-3711-202.....	8	140-0000-951.....	187
133-3304-001.....	17	133-3711-312.....	20	133-8801-211.....	32	135-3711-801.....	9	140-0000-952.....	187
133-3304-001.....	207	133-3711-801.....	22	133-8801-221.....	32	135-3711-802.....	9	140-0000-953.....	187
133-3304-006.....	17	133-3711-802.....	22	133-8801-831.....	35	135-3801-201.....	9	140-0000-954.....	188
133-3304-006.....	207	133-3801-201.....	18	133-8901-801.....	33	135-3801-811.....	9	140-0000-955.....	187
133-3304-401.....	17	133-3801-206.....	18	133-8901-821.....	34	135-9402-001.....	12	140-0000-956.....	188
133-3304-401.....	207	133-3801-211.....	18	133-9402-101.....	208	135-9402-001.....	205	140-0000-957.....	189
133-3304-406.....	17	133-3801-216.....	18	133-9403-001.....	37	135-9402-111.....	12	140-0000-958.....	189
133-3304-406.....	207	133-3801-801.....	23	133-9403-001.....	207	135-9402-111.....	199	140-0000-959.....	189
133-3402-001.....	16	133-3801-806.....	23	133-9403-101.....	37	135-9403-001.....	12	140-0000-960.....	189
133-3402-001.....	207	133-3801-821.....	23	133-9403-101.....	208	135-9403-001.....	204	140-0000-961.....	189
133-3402-006.....	16	133-3801-826.....	23	133-9403-104.....	208	135-9403-101.....	12	140-0000-962.....	189
133-3402-006.....	207	133-3801-841.....	21	133-9404-001.....	37	135-9403-101.....	199	140-0000-964.....	189
133-3402-101.....	17	133-3801-846.....	21	133-9404-001.....	207	135-9404-001.....	204	140-0000-965.....	189
133-3402-101.....	210	133-3801-851.....	21	133-9404-101.....	37	135-9436-001.....	12	140-0000-968.....	189
133-3402-106.....	17	133-3801-856.....	21	133-9404-101.....	208	135-9436-001.....	205	140-0000-970.....	187
133-3402-106.....	210	133-3901-401.....	23	133-9701-201.....	38	135-9436-101.....	12	140-0000-971.....	187
133-3403-001.....	16	133-3901-406.....	23	133-9701-211.....	38	135-9436-101.....	200	141-0000-901.....	186
133-3403-001.....	207	133-3901-801.....	23	133-9701-231.....	38	135-9701-201.....	12	141-0000-902.....	186
133-3403-006.....	16	133-3901-806.....	23	133-9701-301.....	38	135-9701-211.....	12	141-0000-903.....	186
133-3403-006.....	207	133-5302-401.....	26	133-9701-311.....	38	135-9701-301.....	13	141-0000-904.....	188
133-3403-101.....	17	133-5302-401.....	207	133-9701-801.....	38	135-9701-311.....	13	141-0000-905.....	186
133-3403-106.....	17	133-5302-406.....	26	134-0303-406.....	240	135-9711-801.....	13	141-0000-907.....	187
133-3403-106.....	210	133-5303-401.....	26	134-0304-406.....	240	135-9711-802.....	13	141-0000-908.....	188
133-3404-001.....	16	133-5303-401.....	207	134-0307-406.....	240	138-4303-407.....	150	141-0000-910.....	187
133-3404-001.....	207	133-5303-406.....	26	134-0308-406.....	240	138-4303-407.....	249	141-0000-911.....	186
133-3404-006.....	16	133-5304-401.....	26	134-1012-011.....	158	138-4304-407.....	150	141-0000-924.....	186
133-3404-006.....	207	133-5304-406.....	26	134-1012-021.....	158	138-4304-407.....	249	141-0000-925.....	186
133-3404-101.....	17	133-5304-401.....	207	134-1012-041.....	159	138-4307-407.....	150	141-0000-927.....	186
133-3404-101.....	210	133-5304-406.....	26	134-1018-001.....	159	138-4307-407.....	252	141-0303-412.....	99
133-3404-106.....	17	133-5402-001.....	26	134-1018-011.....	159	138-4308-407.....	150	141-0303-412.....	219
133-3404-106.....	210	133-5402-001.....	207	134-1018-021.....	159	138-4308-407.....	252	141-0304-412.....	99
133-3407-101.....	17	133-5402-006.....	26	134-1018-031.....	159	138-4316-407.....	150	141-0304-412.....	219
133-3407-101.....	210	133-5402-006.....	207	134-1019-151.....	160	138-4316-407.....	252	141-0307-412.....	99
133-3407-106.....	17	133-5402-006.....	26	134-1019-161.....	160	138-4318-407.....	150	141-0307-412.....	219
133-3407-106.....	210	133-5402-006.....	207	134-1019-171.....	160	138-4318-407.....	252	141-0308-412.....	99
133-3407-106.....	210	133-5402-101.....	26	134-1019-181.....	161	138-4349-407.....	150	141-0308-412.....	219
133-3433-001.....	16	133-5402-101.....	210	134-1019-361.....	180	138-4349-407.....	252	141-0403-012.....	99

141-0403-012.....	219	142-0004-226.....	253	142-0303-411.....	54	142-0407-101.....	53	142-0694-046.....	215
141-0403-102.....	99	142-0004-301.....	155	142-0303-411.....	219	142-0407-101.....	229	142-0694-051.....	51
141-0403-102.....	224	142-0004-301.....	253	142-0303-416.....	54	142-0407-101.....	224	142-0694-051.....	216
141-0404-012.....	99	142-0004-306.....	155	142-0303-416.....	219	142-0407-106.....	53	142-0694-056.....	51
141-0404-012.....	219	142-0004-306.....	253	142-0304-011.....	54	142-0407-106.....	224	142-0694-056.....	216
141-0404-112.....	99	142-0004-801.....	156	142-0304-011.....	219	142-0407-106.....	229	142-0694-101.....	50
141-0404-112.....	224	142-0004-801.....	254	142-0304-016.....	54	142-0408-011.....	53	142-0694-101.....	213
141-0407-012.....	99	142-0004-811.....	156	142-0304-016.....	219	142-0408-011.....	219	142-0694-106.....	50
141-0407-012.....	219	142-0004-811.....	254	142-0304-401.....	54	142-0408-016.....	53	142-0694-106.....	213
141-0407-102.....	99	142-0007-801.....	156	142-0304-401.....	225	142-0408-016.....	219	142-0701-201.....	56
141-0407-102.....	224	142-0007-801.....	254	142-0304-406.....	54	142-0408-101.....	53	142-0701-206.....	56
141-0408-012.....	99	142-0007-811.....	156	142-0304-406.....	225	142-0408-101.....	224	142-0701-231.....	56
141-0408-012.....	219	142-0007-811.....	254	142-0304-411.....	54	142-0408-106.....	53	142-0701-236.....	56
141-0408-102.....	99	142-0008-801.....	156	142-0304-411.....	219	142-0408-106.....	224	142-0701-301.....	57
141-0408-102.....	224	142-0008-801.....	254	142-0304-416.....	54	142-0433-011.....	53	142-0701-306.....	57
141-0593-001.....	98	142-0008-811.....	156	142-0304-416.....	219	142-0433-011.....	219	142-0701-401.....	62
141-0593-001.....	214	142-0008-811.....	254	142-0307-011.....	54	142-0433-016.....	53	142-0701-406.....	62
141-0593-401.....	98	142-0093-801.....	155	142-0307-011.....	219	142-0433-016.....	219	142-0701-411.....	62
141-0593-401.....	214	142-0093-801.....	254	142-0307-016.....	54	142-0433-101.....	53	142-0701-416.....	62
141-0593-421.....	98	142-0093-806.....	254	142-0307-016.....	219	142-0433-101.....	224	142-0701-421.....	56
141-0593-421.....	222	142-0094-801.....	155	142-0307-401.....	54	142-0433-106.....	53	142-0701-426.....	56
141-0594-001.....	98	142-0094-801.....	254	142-0307-401.....	225	142-0433-106.....	224	142-0701-481.....	66
141-0594-001.....	214	142-0094-806.....	254	142-0307-406.....	54	142-0435-001.....	53	142-0701-486.....	66
141-0594-401.....	98	142-0096-801.....	155	142-0307-406.....	225	142-0435-001.....	220	142-0701-491.....	56
141-0594-401.....	214	142-0096-801.....	254	142-0307-411.....	54	142-0435-006.....	53	142-0701-496.....	56
141-0594-421.....	98	142-0096-806.....	254	142-0307-411.....	219	142-0435-006.....	220	142-0701-501.....	57
141-0594-421.....	222	142-0102-401.....	55	142-0307-411.....	220	142-0435-101.....	53	142-0701-506.....	57
141-0693-002.....	97	142-0102-401.....	230	142-0307-416.....	54	142-0435-101.....	229	142-0701-531.....	62
141-0693-002.....	214	142-0102-406.....	55	142-0307-416.....	219	142-0435-106.....	53	142-0701-536.....	62
141-0693-062.....	97	142-0102-406.....	230	142-0307-416.....	220	142-0435-106.....	229	142-0701-551.....	57
141-0693-062.....	222	142-0103-401.....	55	142-0308-011.....	54	142-0439-001.....	53	142-0701-556.....	57
141-0694-002.....	97	142-0103-401.....	230	142-0308-011.....	219	142-0439-001.....	220	142-0701-621.....	67
141-0694-002.....	214	142-0103-406.....	55	142-0308-016.....	54	142-0439-006.....	53	142-0701-626.....	67
141-0694-012.....	97	142-0103-406.....	230	142-0308-016.....	219	142-0439-006.....	220	142-0701-631.....	67
141-0694-012.....	214	142-0107-401.....	55	142-0308-401.....	54	142-0439-101.....	53	142-0701-636.....	67
141-0694-062.....	97	142-0107-401.....	230	142-0308-401.....	225	142-0439-101.....	229	142-0701-801.....	60
141-0694-062.....	222	142-0107-401.....	230	142-0308-406.....	54	142-0439-106.....	53	142-0701-806.....	60
141-0701-201.....	100	142-0107-406.....	55	142-0308-406.....	225	142-0439-106.....	229	142-0701-831.....	60
141-0701-301.....	100	142-0107-406.....	230	142-0308-411.....	54	142-0593-001.....	52	142-0701-836.....	60
141-0701-402.....	100	142-0107-406.....	230	142-0308-411.....	219	142-0593-001.....	214	142-0701-841.....	60
141-0701-602.....	101	142-0202-011.....	55	142-0308-416.....	54	142-0593-006.....	52	142-0701-846.....	60
141-0701-612.....	101	142-0202-011.....	230	142-0308-416.....	219	142-0593-006.....	214	142-0701-851.....	60
141-0701-622.....	101	142-0202-016.....	55	142-0333-011.....	219	142-0593-401.....	52	142-0701-856.....	60
141-0701-632.....	101	142-0202-016.....	230	142-0333-016.....	219	142-0593-401.....	214	142-0701-871.....	61
141-3901-801.....	102	142-0202-101.....	55	142-0333-411.....	54	142-0593-406.....	52	142-0701-876.....	61
141-3901-802.....	102	142-0202-101.....	231	142-0333-411.....	219	142-0593-406.....	214	142-0701-881.....	60
141-3901-803.....	102	142-0202-106.....	55	142-0333-416.....	54	142-0593-411.....	52	142-0701-886.....	60
141-3901-806.....	102	142-0202-106.....	231	142-0333-416.....	219	142-0593-411.....	214	142-0711-201.....	57
141-3901-810.....	102	142-0203-011.....	55	142-0335-401.....	54	142-0593-416.....	214	142-0711-202.....	57
142-0002-221.....	155	142-0203-011.....	230	142-0335-401.....	220	142-0594-001.....	52	142-0711-301.....	57
142-0002-221.....	253	142-0203-016.....	55	142-0335-406.....	54	142-0594-001.....	214	142-0711-302.....	57
142-0002-226.....	155	142-0203-016.....	230	142-0335-406.....	220	142-0594-006.....	52	142-0711-811.....	61
142-0002-226.....	253	142-0203-101.....	55	142-0339-401.....	54	142-0594-006.....	214	142-0711-816.....	61
142-0002-811.....	156	142-0203-101.....	231	142-0339-401.....	220	142-0594-401.....	52	142-0711-821.....	59
142-0002-811.....	254	142-0203-106.....	55	142-0339-406.....	54	142-0594-401.....	214	142-0711-826.....	59
142-0002-821.....	156	142-0203-106.....	231	142-0339-406.....	220	142-0594-406.....	52	142-0711-841.....	59
142-0002-821.....	254	142-0207-011.....	55	142-0402-011.....	53	142-0594-406.....	214	142-0711-846.....	59
142-0003-201.....	155	142-0207-011.....	230	142-0402-011.....	217	142-0693-001.....	50	142-0711-871.....	60
142-0003-201.....	253	142-0207-011.....	230	142-0402-016.....	53	142-0693-001.....	214	142-0711-876.....	60
142-0003-206.....	155	142-0207-016.....	55	142-0402-016.....	217	142-0693-006.....	50	142-0711-881.....	60
142-0003-206.....	253	142-0207-016.....	230	142-0402-101.....	53	142-0693-006.....	214	142-0711-886.....	60
142-0003-231.....	155	142-0207-016.....	230	142-0402-101.....	224	142-0693-051.....	51	142-0721-811.....	60
142-0003-231.....	253	142-0207-101.....	55	142-0402-106.....	53	142-0693-051.....	216	142-0721-816.....	60
142-0003-236.....	155	142-0207-101.....	231	142-0402-106.....	224	142-0693-056.....	51	142-0721-841.....	61
142-0003-236.....	253	142-0207-101.....	231	142-0403-001.....	225	142-0693-056.....	216	142-0721-846.....	61
142-0003-241.....	155	142-0207-106.....	55	142-0403-006.....	225	142-0693-101.....	50	142-0721-861.....	60
142-0003-241.....	253	142-0207-106.....	231	142-0403-011.....	53	142-0693-101.....	213	142-0721-866.....	60
142-0003-246.....	155	142-0207-106.....	231	142-0403-011.....	219	142-0693-106.....	50	142-0721-871.....	61
142-0003-246.....	253	142-0302-011.....	54	142-0403-016.....	53	142-0693-106.....	213	142-0721-876.....	61
142-0003-301.....	155	142-0302-011.....	217	142-0403-016.....	219	142-0694-001.....	50	142-0721-881.....	62
142-0003-301.....	253	142-0302-016.....	54	142-0403-101.....	53	142-0694-001.....	214	142-0721-882.....	62
142-0003-306.....	155	142-0302-016.....	217	142-0403-101.....	224	142-0694-006.....	50	142-0731-861.....	61
142-0003-306.....	253	142-0302-401.....	54	142-0403-106.....	53	142-0694-006.....	214	142-0731-866.....	61
142-0003-801.....	156	142-0302-401.....	225	142-0403-106.....	224	142-0694-011.....	50	142-0761-801.....	92
142-0003-801.....	254	142-0302-406.....	54	142-0404-011.....	53	142-0694-011.....	214	142-0761-801.....	228
142-0003-811.....	156	142-0302-406.....	225	142-0404-011.....	219	142-0694-016.....	50	142-0761-811.....	92
142-0003-811.....	254	142-0302-431.....	54	142-0404-016.....	53	142-0694-016.....	214	142-0761-811.....	228
142-0004-201.....	155	142-0302-431.....	217	142-0404-016.....	219	142-0694-021.....	51	142-0761-821.....	92
142-0004-201.....	253	142-0302-436.....	54	142-0404-101.....	53	142-0694-021.....	215	142-0761-821.....	228
142-0004-206.....	155	142-0302-436.....	217	142-0404-101.....	224	142-0694-026.....	51	142-0761-831.....	92
142-0004-206.....	253	142-0303-011.....	54	142-0404-106.....	53	142-0694-026.....	215	142-0761-831.....	228
142-0004-211.....	155	142-0303-011.....	219	142-0404-106.....	224	142-0694-031.....	51	142-0761-841.....	93
142-0004-211.....	253	142-0303-016.....	54	142-0407-011.....	53	142-0694-031.....	215	142-0761-841.....	228
142-0004-216.....	155	142-0303-016.....	219	142-0407-011.....	219	142-0694-036.....	51	142-0761-851.....	93
142-0004-216.....	253	142-0303-401.....	54	142-0407-011.....	220	142-0694-036.....	215	142-0761-851.....	228
142-0004-221.....	155	142-0303-401.....	225	142-0407-016.....	53	142-0694-041.....	51	142-0761-861.....	93
142-0004-221.....	253	142-0303-406.....	54	142-0407-016.....	219	142-0694-041.....	215	142-0761-861.....	228
142-0004-226.....	155	142-0303-406.....	225	142-0407-016.....	220	142-0694-046.....	51	142-0761-871.....	93

Part Number Index

142-0761-871.....	228	142-1701-571.....	73	142-4403-101.....	80	142-5407-006.....	219	251-0111-003.....	273
142-0761-881.....	92	142-1701-576.....	73	142-4403-101.....	224	142-5407-006.....	220	251-0115-002.....	273
142-0761-881.....	228	142-1701-581.....	73	142-4403-106.....	80	142-5407-101.....	84	415-0001-006.....	169
142-0761-891.....	93	142-1701-586.....	73	142-4403-106.....	224	142-5407-101.....	224	415-0001-012.....	169
142-0761-891.....	228	142-1701-591.....	73	142-4404-001.....	80	142-5407-101.....	229	415-0001-018.....	169
142-0771-821.....	92	142-1701-596.....	73	142-4404-001.....	219	142-5407-106.....	84	415-0001-024.....	169
142-0771-821.....	228	142-1701-601.....	70	142-4404-006.....	80	142-5407-106.....	224	415-0001-030.....	169
142-0771-831.....	93	142-1701-606.....	72	142-4404-006.....	219	142-5407-106.....	229	415-0001-036.....	169
142-0771-831.....	228	142-1701-611.....	72	142-4404-101.....	80	142-5408-001.....	84	415-0002-006.....	169
142-0791-801.....	63	142-1701-616.....	72	142-4404-101.....	224	142-5408-001.....	219	415-0002-012.....	169
142-0791-801.....	227	142-1701-621.....	72	142-4404-106.....	80	142-5408-006.....	84	415-0002-018.....	169
142-0791-801.....	236	142-1701-626.....	72	142-4404-106.....	224	142-5408-006.....	219	415-0002-024.....	169
142-0791-811.....	63	142-1701-631.....	72	142-4407-001.....	80	142-5408-101.....	84	415-0002-030.....	169
142-0791-811.....	227	142-1701-636.....	72	142-4407-001.....	219	142-5408-101.....	224	415-0002-036.....	169
142-0791-811.....	236	142-1701-641.....	72	142-4407-001.....	220	142-5408-106.....	84	415-0003-006.....	168
142-0791-821.....	63	142-1701-646.....	72	142-4407-006.....	80	142-5408-106.....	224	415-0003-012.....	168
142-0791-821.....	227	142-1701-651.....	69	142-4407-006.....	219	142-5435-001.....	84	415-0003-018.....	168
142-0791-821.....	236	142-1701-706.....	69	142-4407-006.....	220	142-5435-001.....	220	415-0003-024.....	168
142-0801-201.....	56	142-1701-821.....	63	142-4407-101.....	80	142-5435-006.....	84	415-0003-030.....	168
142-0801-206.....	56	142-1701-821.....	227	142-4407-101.....	224	142-5435-006.....	220	415-0003-036.....	168
142-0801-301.....	56	142-1701-821.....	236	142-4407-101.....	229	142-5435-101.....	84	415-0004-006.....	169
142-0801-306.....	56	142-1701-831.....	63	142-4407-106.....	80	142-5435-101.....	229	415-0004-012.....	169
142-0801-421.....	55	142-1701-831.....	227	142-4407-106.....	224	142-5435-106.....	84	415-0004-018.....	169
142-0801-421.....	216	142-1701-831.....	236	142-4407-106.....	229	142-5435-106.....	229	415-0004-024.....	169
142-0801-801.....	59	142-1711-001.....	69	142-4408-001.....	80	142-5439-001.....	84	415-0004-030.....	169
142-0801-806.....	59	142-1711-006.....	69	142-4408-001.....	219	142-5439-001.....	220	415-0004-036.....	169
142-0801-811.....	59	142-1711-011.....	70	142-4408-006.....	80	142-5439-006.....	84	415-0005-006.....	169
142-0801-816.....	59	142-1711-016.....	70	142-4408-006.....	219	142-5439-006.....	220	415-0005-012.....	169
142-0801-821.....	59	142-1711-021.....	70	142-4408-101.....	80	142-5439-101.....	84	415-0005-018.....	169
142-0801-826.....	59	142-1711-026.....	70	142-4408-101.....	224	142-5439-101.....	229	415-0005-024.....	169
142-0801-831.....	59	142-1711-031.....	70	142-4408-106.....	80	142-5439-106.....	84	415-0005-030.....	169
142-0801-836.....	59	142-1711-036.....	70	142-4408-106.....	224	142-5439-106.....	229	415-0005-036.....	169
142-0901-401.....	76	142-1711-061.....	70	142-4435-001.....	80	142-5701-201.....	85	415-0006-006.....	169
142-0901-406.....	76	142-1711-066.....	70	142-4435-001.....	220	142-5701-206.....	85	415-0006-012.....	169
142-0901-801.....	76	142-1711-511.....	74	142-4435-006.....	80	142-5701-501.....	85	415-0006-018.....	169
142-0901-806.....	76	142-1711-516.....	74	142-4435-006.....	220	142-5701-506.....	85	415-0006-024.....	169
142-0901-811.....	76	142-1711-521.....	74	142-4435-101.....	80	142-5701-801.....	85	415-0006-030.....	169
142-0901-816.....	76	142-1711-526.....	74	142-4435-101.....	229	142-5701-806.....	85	415-0006-036.....	169
142-0901-821.....	76	142-1721-001.....	65	142-4435-106.....	80	142-5701-811.....	85	415-0007-006.....	169
142-0901-826.....	76	142-1721-006.....	65	142-4435-106.....	229	142-5701-816.....	85	415-0007-012.....	169
142-0901-861.....	77	142-1721-011.....	65	142-4439-001.....	80	142-9303-411.....	87	415-0007-018.....	169
142-0901-866.....	77	142-1721-016.....	65	142-4439-001.....	220	142-9303-411.....	219	415-0007-024.....	169
142-0901-921.....	77	142-1721-021.....	66	142-4439-006.....	80	142-9403-011.....	87	415-0007-030.....	169
142-0901-931.....	77	142-1721-026.....	66	142-4439-006.....	220	142-9403-011.....	219	415-0007-036.....	169
142-0901-941.....	77	142-1721-031.....	66	142-4439-101.....	80	142-9403-101.....	87	415-0008-006.....	169
142-1000-001.....	75	142-1721-036.....	66	142-4439-101.....	229	142-9403-101.....	224	415-0008-012.....	169
142-1000-002.....	75	142-1721-041.....	66	142-4439-106.....	80	142-9404-011.....	87	415-0008-018.....	169
142-1000-003.....	75	142-1721-046.....	66	142-4439-106.....	229	142-9404-011.....	219	415-0008-024.....	169
142-1000-004.....	75	142-1721-051.....	66	142-4701-201.....	81	142-9404-101.....	87	415-0008-030.....	169
142-1000-033.....	44	142-1721-056.....	66	142-4701-206.....	81	142-9404-101.....	224	415-0008-036.....	169
142-1403-001.....	49	142-1731-006.....	64	142-4701-501.....	81	142-9407-001.....	87	415-0009-006.....	169
142-1403-001.....	219	142-1731-011.....	64	142-4701-506.....	81	142-9407-001.....	219	415-0009-012.....	170
142-1403-006.....	219	142-1731-016.....	64	142-4701-801.....	81	142-9407-101.....	87	415-0009-018.....	170
142-1404-001.....	49	142-1731-021.....	64	142-4701-806.....	81	142-9407-101.....	224	415-0009-024.....	170
142-1404-001.....	219	142-1731-026.....	64	142-5303-401.....	84	142-9701-201.....	88	415-0009-030.....	170
142-1404-006.....	219	142-1731-031.....	64	142-5303-401.....	219	142-9701-211.....	88	415-0009-036.....	170
142-1407-001.....	49	142-1731-036.....	64	142-5303-406.....	84	142-9701-301.....	88	415-0010-006.....	169
142-1407-001.....	219	142-1801-551.....	74	142-5303-406.....	219	142-9701-801.....	89	415-0010-012.....	169
142-1407-006.....	219	142-1801-556.....	74	142-5304-401.....	84	142-9701-811.....	89	415-0010-018.....	169
142-1408-001.....	49	142-1801-561.....	74	142-5304-401.....	219	142-9801-201.....	88	415-0010-024.....	169
142-1408-001.....	219	142-1801-566.....	74	142-5304-406.....	84	144-0000-910.....	187	415-0010-030.....	169
142-1408-006.....	219	142-1801-571.....	74	142-5304-406.....	219	144-0000-910.....	273	415-0010-036.....	169
142-1701-011.....	68	142-1801-576.....	74	142-5307-401.....	84	145-0693-001.....	43	415-0011-006.....	170
142-1701-016.....	68	142-1801-601.....	74	142-5307-401.....	219	145-0693-001.....	212	415-0011-012.....	170
142-1701-031.....	67	142-1801-606.....	74	142-5307-406.....	84	145-0693-002.....	43	415-0011-018.....	170
142-1701-036.....	67	142-1801-611.....	74	142-5307-406.....	219	145-0693-002.....	212	415-0011-024.....	170
142-1701-041.....	68	142-1801-616.....	74	142-5308-401.....	84	145-0694-001.....	43	415-0011-030.....	170
142-1701-046.....	68	142-1801-621.....	74	142-5308-401.....	219	145-0694-001.....	212	415-0011-036.....	170
142-1701-121.....	68	142-1801-626.....	74	142-5308-406.....	84	145-0694-002.....	43	415-0013-006.....	170
142-1701-126.....	68	142-1901-821.....	49	142-5308-406.....	219	145-0694-002.....	212	415-0013-012.....	170
142-1701-131.....	67	142-4303-401.....	80	142-5403-001.....	84	145-0701-001.....	43	415-0013-018.....	170
142-1701-136.....	67	142-4303-401.....	219	142-5403-001.....	219	145-0701-002.....	43	415-0013-024.....	170
142-1701-191.....	69	142-4303-406.....	80	142-5403-006.....	84	145-0701-601.....	43	415-0013-030.....	170
142-1701-196.....	69	142-4303-406.....	219	142-5403-006.....	219	145-0701-602.....	43	415-0013-036.....	170
142-1701-201.....	68	142-4304-401.....	80	142-5403-101.....	84	145-0701-611.....	43	415-0014-006.....	164
142-1701-206.....	68	142-4304-401.....	219	142-5403-101.....	224	145-0701-612.....	43	415-0014-012.....	164
142-1701-501.....	72	142-4304-406.....	80	142-5403-106.....	84	145-0901-801.....	44	415-0014-018.....	164
142-1701-506.....	72	142-4304-406.....	219	142-5403-106.....	224	145-0901-811.....	44	415-0014-024.....	164
142-1701-511.....	72	142-4307-401.....	80	142-5404-001.....	84	145-0901-821.....	44	415-0014-030.....	164
142-1701-516.....	72	142-4307-401.....	219	142-5404-001.....	219	146-0403-007.....	184	415-0014-036.....	164
142-1701-521.....	72	142-4307-406.....	80	142-5404-006.....	84	146-0403-007.....	256	415-0015-006.....	164
142-1701-526.....	72	142-4307-406.....	219	142-5404-006.....	219	146-0403-107.....	184	415-0015-012.....	164
142-1701-531.....	73	142-4308-401.....	80	142-5404-101.....	84	146-0403-107.....	255	415-0015-018.....	164
142-1701-536.....	73	142-4308-401.....	219	142-5404-101.....	224	146-0404-007.....	184	415-0015-024.....	164
142-1701-541.....	73	142-4308-406.....	80	142-5404-106.....	84	146-0404-007.....	256	415-0015-030.....	164
142-1701-546.....	73	142-4308-406.....	219	142-5404-106.....	224	146-0404-107.....	184	415-0015-036.....	164
142-1701-551.....	73	142-4403-001.....	80	142-5407-001.....	84	146-0404-107.....	255	415-0016-006.....	164
142-1701-556.....	73	142-4403-001.....	219	142-5407-001.....	219	146-0701-201.....	184	415-0016-012.....	164
142-1701-561.....	73	142-4403-006.....	80	142-5407-001.....	220	146-0701-301.....	184	415-0016-018.....	164
142-1701-566.....	73	142-4403-006.....	219	142-5407-006.....	84	1-8-0313-001.....	268	415-0016-024.....	164

415-0016-030.....	164	415-0032-012.....	167	415-0049-048.....	171	415-0068-012.....	163	415-0086-300.....	174
415-0016-036.....	164	415-0032-018.....	167	415-0049-060.....	171	415-0068-018.....	163	415-0086-500.....	174
415-0017-006.....	164	415-0032-024.....	167	415-0050-012.....	171	415-0068-024.....	163	415-0087-050.....	174
415-0017-012.....	164	415-0032-036.....	167	415-0050-024.....	171	415-0069-006.....	163	415-0087-100.....	174
415-0017-018.....	164	415-0032-048.....	167	415-0050-036.....	171	415-0069-012.....	163	415-0087-150.....	174
415-0017-024.....	164	415-0033-006.....	165	415-0050-048.....	171	415-0069-018.....	163	415-0087-200.....	174
415-0017-030.....	164	415-0033-012.....	165	415-0050-060.....	171	415-0069-024.....	163	415-0087-250.....	174
415-0017-036.....	164	415-0033-018.....	165	415-0051-012.....	171	415-0070-006.....	163	415-0087-300.....	174
415-0018-006.....	164	415-0033-024.....	165	415-0051-024.....	171	415-0070-012.....	163	415-0087-500.....	174
415-0018-012.....	164	415-0033-036.....	165	415-0051-036.....	171	415-0070-018.....	163	415-0088-050.....	174
415-0018-018.....	164	415-0033-048.....	165	415-0051-048.....	171	415-0070-024.....	163	415-0088-100.....	174
415-0018-024.....	164	415-0034-006.....	167	415-0051-060.....	171	415-0070-036.....	163	415-0088-150.....	174
415-0018-030.....	164	415-0034-012.....	167	415-0052-012.....	171	415-0071-006.....	163	415-0088-200.....	174
415-0018-036.....	164	415-0034-018.....	167	415-0052-024.....	171	415-0071-012.....	163	415-0088-250.....	174
415-0020-006.....	164	415-0034-024.....	167	415-0052-036.....	171	415-0071-018.....	163	415-0088-300.....	174
415-0020-012.....	164	415-0034-036.....	167	415-0052-048.....	171	415-0071-024.....	163	415-0088-500.....	174
415-0020-018.....	164	415-0034-048.....	167	415-0052-060.....	171	415-0071-036.....	163	415-0089-150.....	176
415-0020-024.....	164	415-0035-006.....	166	415-0053-012.....	171	415-0072-006.....	163	415-0089-250.....	176
415-0020-030.....	164	415-0035-012.....	166	415-0053-024.....	171	415-0072-012.....	163	415-0090-150.....	176
415-0020-036.....	164	415-0035-018.....	166	415-0053-036.....	171	415-0072-018.....	163	415-0090-250.....	176
415-0021-006.....	164	415-0035-024.....	166	415-0053-048.....	171	415-0072-024.....	163	415-0091-150.....	176
415-0021-012.....	164	415-0035-036.....	166	415-0053-060.....	171	415-0072-036.....	163	415-0091-250.....	176
415-0021-018.....	164	415-0035-048.....	166	415-0054-012.....	170	415-0073-006.....	163	415-0092-150.....	177
415-0021-024.....	164	415-0036-006.....	167	415-0054-024.....	170	415-0073-012.....	163	415-0092-250.....	177
415-0021-030.....	164	415-0036-012.....	167	415-0054-036.....	170	415-0073-018.....	163	415-0093-150.....	177
415-0021-036.....	164	415-0036-018.....	167	415-0054-048.....	170	415-0073-024.....	163	415-0093-250.....	177
415-0022-006.....	165	415-0036-024.....	167	415-0054-060.....	170	415-0073-036.....	163	415-0094-150.....	177
415-0022-012.....	165	415-0036-036.....	167	415-0056-012.....	170	415-0074-006.....	168	415-0094-250.....	177
415-0022-018.....	165	415-0036-048.....	167	415-0056-024.....	170	415-0074-012.....	168	415-0095-150.....	176
415-0022-024.....	165	415-0037-012.....	171	415-0056-036.....	170	415-0074-024.....	168	415-0095-250.....	176
415-0022-030.....	165	415-0037-024.....	171	415-0056-048.....	170	415-0074-036.....	168	415-0096-150.....	176
415-0022-036.....	165	415-0037-036.....	171	415-0056-060.....	170	415-0074-048.....	168	415-0096-250.....	176
415-0023-006.....	165	415-0037-048.....	171	415-0057-012.....	170	415-0075-006.....	168	415-0097-150.....	176
415-0023-012.....	165	415-0037-060.....	171	415-0057-024.....	170	415-0075-012.....	168	415-0097-250.....	176
415-0023-018.....	165	415-0038-012.....	165	415-0057-036.....	170	415-0075-018.....	168	415-0098-150.....	177
415-0023-024.....	165	415-0038-024.....	165	415-0057-048.....	170	415-0075-024.....	168	415-0098-250.....	177
415-0023-030.....	165	415-0038-036.....	165	415-0057-060.....	170	415-0075-036.....	168	415-0099-150.....	177
415-0023-036.....	165	415-0038-048.....	165	415-0058-012.....	170	415-0075-048.....	168	415-0099-250.....	177
415-0024-006.....	165	415-0038-060.....	165	415-0058-024.....	170	415-0076-012.....	168	415-0099-500.....	177
415-0024-012.....	165	415-0040-012.....	166	415-0058-036.....	170	415-0076-024.....	168	415-0100-150.....	177
415-0024-018.....	165	415-0040-024.....	166	415-0058-048.....	170	415-0076-036.....	168	415-0100-250.....	177
415-0024-024.....	165	415-0040-036.....	166	415-0058-060.....	170	415-0077-012.....	168	415-0101-150.....	175
415-0024-030.....	165	415-0040-048.....	166	415-0059-012.....	171	415-0077-024.....	168	415-0101-250.....	175
415-0024-036.....	165	415-0040-060.....	166	415-0059-024.....	171	415-0077-036.....	168	415-0102-150.....	175
415-0025-006.....	165	415-0041-012.....	167	415-0059-036.....	171	415-0078-012.....	168	415-0102-250.....	175
415-0025-012.....	165	415-0041-024.....	167	415-0059-048.....	171	415-0078-024.....	168	415-0104-150.....	178
415-0025-018.....	165	415-0041-036.....	167	415-0059-060.....	171	415-0078-036.....	168	415-0104-250.....	178
415-0025-024.....	165	415-0041-048.....	167	415-0060-012.....	170	415-0079-012.....	168	415-0105-150.....	178
415-0025-036.....	165	415-0041-060.....	167	415-0060-024.....	170	415-0079-024.....	168	415-0105-250.....	178
415-0025-048.....	165	415-0042-012.....	171	415-0060-036.....	170	415-0079-036.....	168	415-0106-150.....	178
415-0026-006.....	167	415-0042-024.....	171	415-0060-048.....	170	415-0081-003.....	166	415-0106-250.....	178
415-0026-012.....	167	415-0042-036.....	171	415-0060-060.....	170	415-0081-004.....	166	415-0107-150.....	178
415-0026-018.....	167	415-0042-048.....	171	415-0061-012.....	171	415-0081-005.....	166	415-0107-250.....	178
415-0026-024.....	167	415-0042-060.....	171	415-0061-024.....	171	415-0081-006.....	166	415-0108-150.....	178
415-0026-036.....	167	415-0043-012.....	165	415-0061-036.....	171	415-0081-007.....	166	415-0108-250.....	178
415-0026-048.....	167	415-0043-024.....	165	415-0061-048.....	171	415-0081-008.....	166	415-0162-006.....	172
415-0027-006.....	167	415-0043-036.....	165	415-0061-060.....	171	415-0081-012.....	166	415-0162-012.....	172
415-0027-012.....	167	415-0043-048.....	165	415-0062-012.....	170	415-0081-018.....	166	415-0162-024.....	172
415-0027-018.....	167	415-0043-060.....	165	415-0062-024.....	170	415-0081-024.....	166	415-0162-036.....	172
415-0027-024.....	167	415-0044-012.....	167	415-0062-036.....	170	415-0082-004.....	166	415-0162-048.....	172
415-0027-036.....	167	415-0044-024.....	167	415-0062-048.....	170	415-0082-005.....	166	415-0163-006.....	172
415-0027-048.....	167	415-0044-036.....	167	415-0062-060.....	170	415-0082-006.....	166	415-0163-012.....	172
415-0028-006.....	171	415-0044-048.....	167	415-0063-012.....	170	415-0082-007.....	166	415-0163-024.....	172
415-0028-012.....	171	415-0044-060.....	167	415-0063-024.....	170	415-0082-008.....	166	415-0163-036.....	172
415-0028-018.....	171	415-0045-012.....	166	415-0063-036.....	170	415-0082-012.....	166	415-0163-048.....	172
415-0028-024.....	171	415-0045-024.....	166	415-0063-048.....	170	415-0082-018.....	166	415-0165-006.....	172
415-0028-036.....	171	415-0045-036.....	166	415-0063-060.....	170	415-0082-024.....	166	415-0165-012.....	172
415-0028-048.....	171	415-0045-048.....	166	415-0064-006.....	168	415-0084-050.....	174	415-0165-024.....	172
415-0029-006.....	165	415-0045-060.....	166	415-0064-012.....	168	415-0084-100.....	174	415-0165-036.....	172
415-0029-012.....	165	415-0046-012.....	167	415-0064-024.....	168	415-0084-150.....	174	415-0165-048.....	172
415-0029-018.....	165	415-0046-024.....	167	415-0064-036.....	168	415-0084-200.....	174	415-0166-006.....	172
415-0029-024.....	165	415-0046-036.....	167	415-0064-048.....	168	415-0084-250.....	174	415-0166-012.....	172
415-0029-036.....	165	415-0046-048.....	167	415-0065-006.....	168	415-0084-300.....	174	415-0166-024.....	172
415-0029-048.....	165	415-0046-060.....	167	415-0065-012.....	168	415-0084-500.....	174	415-0166-036.....	172
415-0030-006.....	167	415-0047-012.....	171	415-0065-018.....	168	415-0085-050.....	174	415-0166-048.....	172
415-0030-012.....	167	415-0047-024.....	171	415-0065-024.....	168	415-0085-100.....	174	CPN-1.....	242
415-0030-018.....	167	415-0047-036.....	171	415-0065-036.....	168	415-0085-150.....	174	CPN-110.....	242
415-0030-024.....	167	415-0047-048.....	171	415-0065-048.....	168	415-0085-200.....	174	CPN-142T.....	242
415-0030-024.....	167	415-0047-060.....	171	415-0065-060.....	163	415-0085-250.....	174	CPN-16.....	242
415-0030-036.....	167	415-0048-012.....	171	415-0066-012.....	163	415-0085-300.....	174	CPN-17.....	242
415-0031-006.....	166	415-0048-024.....	171	415-0066-018.....	163	415-0085-500.....	174	CPN-2.....	242
415-0031-012.....	166	415-0048-036.....	171	415-0066-024.....	163	415-0086-050.....	174	CPN-68-1.....	241
415-0031-018.....	166	415-0048-048.....	171	415-0067-006.....	163	415-0086-100.....	174	CPN-68-13.....	241
415-0031-024.....	166	415-0048-060.....	171	415-0067-012.....	163	415-0086-150.....	174	CPN-68-8.....	241
415-0031-036.....	166	415-0049-012.....	171	415-0067-018.....	163	415-0086-200.....	174	CPN-8.....	242
415-0031-048.....	166	415-0049-024.....	171	415-0067-024.....	163	415-0086-250.....	174	M22520/1-01.....	273
415-0032-006.....	167	415-0049-036.....	171	415-0068-006.....	163				

Competitor Cross Reference

ADC EMERSON	2009-7511-000.....131-1701-206	9030-9023-003.....142-0303-416	221984-5.....CPFI-UG88-3	228214-1.....131-3403-116
BNC-1.....CPMC-68-35	2009-7511-000.....131-3701-206	9030-9023-006.....142-0307-416	221984-7.....CPFI-UG88-1	228214-2.....131-1402-116
BNC-2.....CPMC-68-2	2010-1511-000.....131-1701-371	9030-9023-019.....142-0304-416	221988-1.....CP-AD506	228214-2.....131-3402-116
BNC-3.....CPMC-68-33	2010-1511-000.....131-3701-301	9043-1523-002.....142-0402-101	222165-2.....CP-AD503	228215-1.....131-3701-406
BNC-4.....CPMC-68-3	2010-7511-000.....131-1701-376	9043-1523-003.....142-0403-101	222319-1.....CP-AD512	228216-1.....131-3701-416
BNC-6.....CPMC-68-10	2010-7511-000.....131-3701-306	9043-1523-006.....142-0407-101	222321-1.....CP-AD809	228226-1.....CP-AD556
BNC-6.....CPMC-68-50	2018-1511-001.....131-3701-801	9044-9513-000.....142-1701-606	222428-1.....CPFI-UG89-2	228509-9.....CP-625U
BNC-7.....CPMC-68-18	2018-7511-001.....131-3701-806	9044-9513-001.....142-1701-616	222506-2.....CPMC-TNC-2	3-227079-0.....CPMC-88-5
BNC-8.....CPMC-68-45	2019-1511-000.....131-3701-411	9045-9513-000.....142-1701-506	222506-4.....CPMC-TNC-13	3-227079-1.....CPMC-88-5
BNC-10.....CPMC-68-36	2019-7511-000.....131-3701-416	9045-9513-001.....142-1701-516	225395-1.....CPMC-88-1	3-227079-2.....CPMC-88-5
BNC-13.....CPMC-68-34	2025-1511-000.....131-3801-201	9046-9513-000.....142-1801-606	225395-2.....CPMC-88-2	3-227079-7.....CPMC-88-14
	2025-7511-000.....131-3801-216	9046-9513-001.....142-1801-616	225395-5.....CPMC-88-1	3-227086-6.....CPN-1
AEP EMERSON	2042-1511-000.....131-1801-371	9048-9513-000.....142-1701-626	225395-6.....CPMC-88-13	329517.....CP-AD503
204.....131-3701-401	2042-1511-000.....131-3801-301	9049-9513-000.....142-1701-526	225395-7.....CPM-88-19	329518.....CP-AD505
209.....131-1701-201	2042-7511-000.....131-1801-376	9050-9513-000.....142-1801-626	225395-8.....CPM-88-20	330024.....CP-AD556
209.....131-3701-201	2042-7511-000.....131-3801-316	9074-9513-000.....142-1701-576	225395-9.....CPMC-88-14	331350.....CPMC-88-2
210.....131-1701-371	2105-1521-002.....131-1402-101	9076-1113-000.....142-1701-011	225532-1.....142-0407-016	4-227079-1.....CPMC-88-1
210.....131-3701-301	2105-1521-002.....131-3402-101	9076-9113-000.....142-1701-016	225532-9.....142-0407-016	4-227079-3.....CPMC-88-1
219.....131-3701-411	2105-1521-003.....131-1403-101	9079-9513-000.....142-1701-556	225542-1.....142-0307-016	4-227079-9.....CPMC-88-10
222.....131-3901-401	2105-1521-003.....131-3403-101	9079-9513-001.....142-1701-566	225608-9.....142-0307-416	4-331350-0.....CPMC-88-3
225.....131-3801-201	2105-7521-002.....131-1402-116	9101-1573-003.....142-0403-001	225609-1.....142-0407-101	413592-2.....CP-AD505
242.....131-1801-371	2105-7521-002.....131-3402-116	9130-1573-002.....142-0302-401	225609-4.....142-0403-101	413592-9.....CP-AD505
242.....131-3801-301	2105-7521-003.....131-1403-116	9130-1573-003.....142-0303-401	225661-2.....CPN-1	413771-3.....CP-89-19-BM1
1-104.....131-6701-401	2105-7521-003.....131-3403-116	9130-1573-006.....142-0307-401	225886-4.....CPMC-88-26	414160-7.....CPN-68-13
1-109.....131-6701-201	2110-1511-000.....131-3701-341	9201-1553-002.....142-0202-011	226279-1.....CPL-259-1	414160-9.....CPN-68-1
1-110.....131-6701-301	2110-7511-000.....131-3701-346	9201-1553-003.....142-0203-011	226279-2.....CPL-259-8	414168-3.....CP-TNC-89-19-BM
1-119.....131-6701-411	218/063.....131-3701-801	9201-1553-006.....142-0207-011	226279-3.....CPL-259-2	414265-1.....CPFI-UG88-1
1-302/188.....131-6403-001	2484-1511-000.....131-3701-631	9230-1553-002.....142-0102-401	226600-1.....MINI-UHF-1	414265-3.....CPFI-UG89-2
1-303/188.....131-6303-401	2484-7511-000.....131-3701-636	9230-1553-003.....142-0103-401	227000-5.....CPMC-TNC-1	414265-4.....CPFI-UG88-10
1-305/188.....131-6403-101	401/188.....131-3303-001	9243-1553-002.....142-0202-101	227000-7.....CPMC-TNC-2	414265-5.....CPFI-UG88-3
1002-1571-003.....131-6403-001	401/196.....131-3302-001	9243-1553-003.....142-0203-101	227079-1.....CPMC-88-1	414311-1.....CP-AD506
1002-7571-003.....131-6403-006	402/188.....131-1403-001	9243-1553-006.....142-0207-101	227079-2.....CPMC-88-13	414414-1.....CP-AD555
1003-1571-003.....131-6303-401	402/188.....131-3403-001	9301-1063-109.....142-0694-021	227079-3.....CPMC-88-2	414459-1.....CP-BNC-PC-016
1003-7571-003.....131-6303-406	402/196.....131-3402-001	9304-1113-013.....142-1701-191	227079-5.....CPMC-88-1	414580-2.....CPFI-UG88-1
1004-1511-000.....131-6701-401	405/188.....131-1403-101	9304-9113-013.....142-1701-196	227079-7.....CPMC-88-2	414580-3.....CPFI-UG89-2
1004-7511-000.....131-6701-406	405/188.....131-3403-101	9308-1113-001.....142-1701-201	227079-9.....CPMC-88-1	414580-5.....CPFI-UG88-10
1009-1511-000.....131-6701-201	405/196.....131-1402-101	9308-9113-001.....142-1701-206	227632-1.....131-6701-406	414586-1.....CPMC-88-1
1009-7511-000.....131-6701-206	405/196.....131-3402-101	9401-1083-010.....142-0693-001	227633-1.....131-6701-416	414586-5.....CPMC-88-1
1010-1511-000.....131-6701-301	5222-1501-000.....131-3901-401	9401-1083-109.....142-0694-001	227677-1.....CP-BNC-PC-009	414666-1.....CP-AD503
1019-1511-000.....131-6701-411	5222-7501-000.....131-3901-406	9402-1083-009.....142-0594-001	227726-3.....CP-AD520	51751-1.....131-6303-401
1019-7511-000.....131-6701-416	5909-1103-000.....142-0901-401	9402-1083-010.....142-0593-001	227754-1.....CP-1094-U	51751-3.....131-6303-401
1105-1521-003.....131-6403-101	5917-1103-000.....142-0901-801	9404-1113-000.....142-0701-631	227754-2.....CP-1094-U	51753-1.....131-6403-101
1105-7521-003.....131-6403-106	5918-1103-000.....142-0901-811	9408-1113-000.....142-0701-621	227754-3.....CP-1094-U	51753-4.....131-6403-101
1110-1511-000.....131-6701-341	9001-1023-001.....142-0408-011	9412-1113-000.....142-0701-401	227945-2.....CP-AD850	5-227079-8.....CPMC-88-3
1110-7511-000.....131-6701-346	9001-1023-003.....142-0403-011	9413-1113-000.....142-0701-411	227945-5.....CP-AD850	5-331350-3.....CPMC-88-2
2001-1571-002.....131-3302-001	9001-1023-006.....142-0407-011	9424-1513-000.....142-0701-701	227839-1.....CP-TNC-PC-002	5801-7985-63.....133-3693-001
2001-1571-003.....131-3303-001	9001-1023-019.....142-0404-011	9424-9513-000.....142-0701-706	228226-3.....CP-AD556	5818-5002-10.....142-0003-236
2001-7571-002.....131-3302-006	9001-9023-001.....142-0408-016	9453-1083-009.....142-0594-401	227984-1.....CPFI-UG88-2	5818-5003-10.....142-0003-246
2001-7571-003.....131-3303-006	9001-9023-003.....142-0403-016	9453-1083-010.....142-0593-401	228026-2.....131-6402-006	5818-5005-10.....142-0002-226
2002-1541-010.....131-3693-001	9001-9023-006.....142-0407-016	9504-9113-009.....142-1701-546	228026-3.....131-6403-006	5831-5002-10.....133-3402-006
2002-1571-002.....131-3402-001	9001-9023-019.....142-0404-016	9504-9113-031.....142-1701-536	228028-1.....131-6303-406	5831-5003-10.....133-3403-006
2002-1571-003.....131-1403-001	9002-1023-003.....142-0303-011	9508-9113-001.....142-1701-646	228028-3.....131-6303-406	5837-5002-10.....133-3402-106
2002-1571-003.....131-3403-001	9002-1023-006.....142-0307-011	9508-9113-002.....142-1701-636	228030-1.....131-6403-106	5837-5003-10.....133-3403-106
2002-7541-010.....131-3693-016	9002-1023-019.....142-0304-011	9576-9113-001.....142-1701-586	228030-2.....131-6402-106	5837-5010-63.....133-3403-101
2003-1541-010.....131-3593-401	9002-9023-001.....142-0308-016	9576-9113-003.....142-1701-596	228030-3.....131-6403-106	5862-5002-10.....133-3701-216
2003-7541-010.....131-3593-406	9002-9023-003.....142-0303-016	9609-1513-000.....142-0701-531	228212-1.....131-1701-206	5862-5003-10.....133-3701-206
2004-1511-000.....131-3701-401	9002-9023-006.....142-0307-016	9609-9513-000.....142-0701-536	228212-1.....131-3701-206	5862-5004-10.....133-3701-226
2004-7511-000.....131-3701-406	9002-9023-019.....142-0304-016	9649-1113-000.....142-0801-201	228213-1.....131-1403-016	5863-0000-10.....133-3801-201
2005-1541-010.....131-1693-101	9030-0123-001.....142-0308-411	9650-1113-000.....142-0701-201	228213-1.....131-3403-016	5864-5001-10.....133-3701-306
2005-1541-010.....131-3693-101	9030-1023-003.....142-0303-411		228213-2.....131-3402-016	5864-5002-10.....133-3701-326
2005-7541-010.....131-3693-116	9030-1023-006.....142-0307-411	AMP SEETICO/AMP	228213-3.....131-1403-016	5864-5003-10.....133-3701-316
2009-1511-000.....131-1701-201	9030-1023-019.....142-0304-411	AMP EMERSON	228213-3.....131-3403-016	6-227079-0.....CPMC-88-13
2009-1511-000.....131-3701-201	9030-9023-001.....142-0308-416	221984-1.....CPFI-UG88-2	228214-1.....131-1403-116	6-227079-1.....CPMC-88-13

Competitor Cross Reference

6-227079-2.....CPMC-88-13	31-217.....CP-AD807	31-5980-RFX.....CP-AD558	901-165.....CP-AD583	901-9953-RFX.....142-0307-011
6-227079-5.....CPMC-88-5	31-218.....CP-AD511	31-6-RFX.....CP-BNC-CAP-1	901-166.....CP-AD508	901-9954-RFX.....142-0303-011
6-227079-7.....CPMC-88-11	31-218-RFX.....CP-AD511	31-70008.....CPMC-68-2	901-130.....142-0207-101	901-9955-RFX.....142-0307-411
BNC58HPC.....CPMC-88-1	31-219.....CP-AD555	31-70008.....CPMC-78-2	901-140.....142-0203-101	901-9978-RFX.....142-1701-511
BNC58J.....CP-89-1	31-219RFX.....CP-AD555	31-70036.....CP-AD705	901-143-6RFX.....142-0701-301	901-9979-RFX.....142-1701-611
BNC58PC.....CPMC-88-1	31-2208.....CP-AD505	31-70222.....CPMC-78-3	901-144-8RFX.....142-0701-201	901-9984-RFX.....142-0901-811
BNC58PP.....CPMC-88-11	31-221.....CP-1094U	31-70234.....CPMC-68-45	901-149.....142-0407-101	901-9985-RFX.....142-0901-801
BNC58PTV.....CPFI-UG-88-1	31-221-RFX.....CP-1094U	31-70235.....CPMC-68-3	901-155.....142-0403-001	901-9986-RFX.....142-0901-401
BNC59HPC.....CPMC-88-2	31-2218.....CP-AD511	31-70236.....CPMC-68-18	901-168.....CP-AD311	901-9987-RFX.....142-0901-821
BNC59J.....CP-89-2	31-2221.....CP-1094U	31-70237.....CPMC-68-35	901-191.....142-0901-401	901-B2501-519.....CP-AD507
BNC59JTW.....CPFI-UG89-2	31-2242-RFX.....CPM-TNC-19	31-70238.....CPMC-68-33	901-255.....142-0102-401	901-B2501-520.....CP-AD508
BNC59P.....CPMC-88-2	31-2315-RFX.....CPM-TNC-19	31-71008.....CPMC-78-2	901-256.....142-0103-401	903-284-52S.....131-6403-001
BNC59PC.....CPMC-88-2	31-2318-RFX.....CP-TNC-89-19-BM	31-71008-2000.....CPMC-78-10	901-276.....142-0901-821	903-285P-51S.....131-1403-001
BNC59PC75.....CPMC-78-2	31-236.....CP-1094U	31-71008-RFX.....CPMC-78-2	901-281.....142-0202-011	903-285P-51S.....131-3403-001
BNC59PP.....CPMC-88-10	31-2367-RFX.....CPMC-TNC-1	31-71013.....CPMC-68-20	901-292.....CP-AD817	903-287P-51S.....131-3402-001
BNC59PPC.....CPMC-88-10	31-2368-RFX.....CPMC-TNC-1	31-71032.....CPMC-78-3	901-293.....CP-AD818	903-288P-52A.....131-6403-101
BNC59PTW.....CPFI-UG88-2	31-2373.....CPMC-TNC-13	31-71042-RFX.....CP-BNCPC-012	901-294.....CP-AD810	903-289P-51A.....131-1403-101
BNC59PTWP.....CPFI-UG88-10	31-242.....CPM-88-20	31-71043-RFX.....CP-BNCPC-010	901-295.....CP-AD819	903-289P-51A.....131-3403-101
BNC8281HPS.....CPMC-88-3	31-242-RFX.....CPM-88-20	31-71047-10-RFX.....CP-BNCPC-016	901-302.....142-0901-801	903-291P-51A.....131-1402-101
BNCBHS.....CP-AD556	31-245-RFX.....CP-79-20-BM1	31-71058-RFX.....CP-BNCPC-008	901-303.....142-0901-811	903-291P-51A.....131-3402-101
BNCILS.....CP-AD555	31-28.....CP-AD500	31-8.....CP-AD505	901-367.....142-0202-101	903-305J-51R.....131-3701-401
BNCISJ.....CP-AD520	31-315.....CPM-88-19	31-830.....CP-AD809	901-9183-1.....142-0694-031	903-373J-51A.....131-1701-371
BNCTC.....CP-AD505	31-315-RFX.....CPM-88-19	31-9.....CP-AD503	901-9201-2A.....142-0693-001	903-373J-51A.....131-3701-301
F59PIC.....CPF-59-1/4	31-318-RFX.....CP-89-19-BM1	31-9-RFX.....CP-AD503	901-9202-1A.....142-0594-001	903-376J-51A.....131-3701-341
NP8C.....CP-N-1	31-320.....CPMC-88-1	36650-3RFX1.....CPMC-88-11	901-9202-2A.....142-0593-001	903-402J-51R.....131-3701-411
TNC58P.....CPMC-TNC-1	31-320-1006.....CPMC-88-11	36650-RFX.....CPMC-88-11	901-9207-1.....142-0694-021	903-407J-51R.....131-3701-421
TNC58PC.....CPMC-TNC-1	31-320-RFX.....CPMC-88-1	37-71008-RFX.....CPMC-78-2	901-9210-1.....142-0594-401	903-408J-52R.....131-6701-411
TNC59P.....CPMC-TNC-2	31-321.....CPMC-88-2	68175-1004.....CPMC-88-2	901-9210-2.....142-0593-401	903-419J-52A.....131-6701-341
TNC59PC.....CPMC-TNC-2	31-321-1 RFX1.....CPMC-88-2	68175-1005.....CPMC-88-2	901-9215.....142-0701-631	903-420J-52P.....131-6701-201
TNCBHS.....CP-AD356	31-321-1000.....CPMC-88-3	68175-11-RFX.....CPMC-88-10	901-9220.....142-0701-411	903-422J-51A.....131-3303-501
TNCILS.....CP-AD355	31-321-RFX1.....CPMC-88-2	68175-5-RFX.....CPMC-88-2	901-9221-1A.....142-0694-101	903-550P-51SX.....131-1403-001
	31-3220.....CP-AD521	68175-5RFX1.....CPMC-88-2	901-9221-2A.....142-0693-101	903-551P-52SX.....131-6403-001
AMPHENOL.....EMERSON	31-323.....CPMC-88-14	79100-NRFX.....CP-AD356	901-9244-2.....142-0701-621	903-552J-51SX.....131-3303-001
27-10.....131-6303-401	31-325.....CPMC-88-18	81-115.....MINI-UHF-1	901-9511-1.....142-0408-011	903-555J-52SX.....131-6303-401
27-101.....131-6701-401	31-326.....CPMC-88-13	81-115-RFX.....MINI-UHF-1	901-9511-12SF.....142-0404-016	903-556P-51AX.....131-3403-101
27-175.....131-1801-371	31-326-RFX.....CPMC-88-3	82-100.....CP-AD800	901-9511-12SFC.....142-0404-016	903-557P-52AX.....131-6403-101
27-175.....131-3801-301	31-4791.....CP-AD355	82-100-RFX.....CP-AD800	901-9511-1S.....142-0408-016	903-558P-51AX.....131-1403-101
27-2.....131-3303-001	31-4791-RFX.....CP-AD355	82-101.....CP-AD850	901-9511-1SFC.....142-0408-016	903-561P-51PX.....131-3801-201
27-31.....131-3302-001	31-4803.....CP-AD521	82-101-RFX.....CP-AD850	901-9511-3.....142-0403-011	903-564J-52PX.....131-6701-201
27-5.....131-3901-401	31-4803-RFX.....CP-AD580	82-24.....CP-AD801	901-9511-3SF.....142-0403-016	903-565P-51A.....131-3801-301
27-5050.....131-3693-001	31-5136.....CPFI-UG88-2	82-36.....CP-AD803	901-9511-3SFC.....142-0403-016	903-566P-52A.....131-6801-301
27-5052.....131-1693-101	31-5136-RFX.....CPFI-UG88-2	82-4352-1.....CPN-8	901-9531-3.....142-0403-101	903-567J-51A.....131-3701-301
27-5052.....131-3693-101	31-5137.....CPFI-UG88-1	82-4426-11-RFX.....CPN-8	901-9867-RFX.....142-0693-001	903-568J-52A.....131-6701-301
27-845.....131-6303-401	31-5137-RFX.....CPFI-UG88-1	82-5375.....CPN-1	901-9868-RFX.....142-0694-001	903-569J-51RX.....131-3701-411
27-849.....131-3303-001	31-5138.....CPFI-UG89-2	82-5375-RFX.....CPN-1	901-9876-RFX.....142-0407-011	903-570J-52RX.....131-6701-411
2900.....CP-AD512	31-5141.....CPMC-88-18	82-5380.....CPN-2	901-9877-RFX.....142-0403-011	903-571J-51RX.....131-3701-401
2925.....CP-AD512	31-5151.....CPFI-UG88-3	82-61.....CPN-8	901-9879-RFX.....142-0303-411	903-572J-52RX.....131-6701-401
5575.....CP-1094U	31-5156.....CPMC-88-2	82-64.....CP-AD803	901-9880-RFX.....142-0407-101	908-21103.....135-3801-201
12025.....CP-AD500	31-5157.....CPMC-TNC-2	82-97-RFX.....CP-AD801	901-9881-RFX.....142-0403-101	908-22100.....135-3711-801
17450.....CP-AD506	31-5369-RFX.....CPFI-UG88-10	83-15P-15-RFX.....CP-AD250	901-9889-RFX.....142-0701-411	908-24100.....135-3701-301
34525.....CPN-2	31-5493-RFX.....CP-BNCPC-007	83-1F.....CP-AD207	901-9890-RFX.....142-0701-401	908-41200.....135-3402-001
36650.....CPMC-88-14	31-5556-RFX.....CP-88-2	83-1J.....CP-AD204	901-9891-RFX.....142-1701-131	908-41300.....135-3403-001
36875.....CPMC-88-13	31-5557-RFX.....CP-88-5	83-1J-RFX.....CP-AD204	901-9892-RFX.....142-0701-631	908-41500.....135-3404-001
68175.....CPMC-88-2	31-5558-RFX.....CPMC-88-1	83-1R.....CP-AD206	901-9893-RFX.....142-0701-621	908-42300.....135-3303-001
79100.....CP-AD356	31-5560-RFX.....CP-88-10	83-1R-RFX.....CP-AD206	901-9894-RFX.....142-0801-301	908-43200.....135-3402-101
79675.....CP-AD300	31-5633.....CP-BNCPC-005	83-58FCP-RFX.....CPL-259-1	901-9895-RFX.....142-0801-201	908-43300.....135-3403-101
31-10.....CP-AD520	31-5640-RFX.....CP-BNCPC-009	83-58SCP.....CPL-259-1	901-9940-RFX.....142-0694-011	908-43400.....135-3693-101
31-10-75-RFX.....CP-AD520	31-5888-RFX.....CP-TNC-PC-002	83-58SCP-RFX.....CPL-259-1	901-9943-RFX.....142-0593-001	908-43500.....135-3404-101
31-10-RFX.....CP-AD520	31-5893-RFX.....CP-AD355	83-59DCP.....CPL-259-2	901-9944-RFX.....142-0594-001	BNC-AAPJ.....CP-AD503
31-203.....CP-AD519	31-5900.....CPMC-88-21	83-59DCP-RFX.....CPL-259-2	901-9945-RFX.....142-0593-401	BNC-AS-JJ.....CP-AD555
31-203-RFX.....CP-AD519	31-5912-RFX.....CPMC-88-19	83-85P.....CPL-259-8	901-9946-RFX.....142-0594-401	BNC-PC2C-P5962.....CP-88-10
31-208.....CP-AD505	31-5913-RFX.....CPMC-78-20	83-85P-RFX.....CPL-259-8	901-9951-RFX.....142-0693-101	BNC-PS2C-58.....CP-88-1
31-208RFX.....CP-AD505	31-5976-50-RFX.....CP-BNCPC-001	901-164.....CP-AD582	901-9952-RFX.....142-0694-101	BNC-PS2C-5962.....CP-88-2

For more information, please contact customer service at (507) 833-8822 or (800) 247-8256 • cinch.com

3131-18-1.....142-1701-521	01-2255-3.....108-0754-001	9852-0081-6220.....142-1801-626	1464-105.....111-0110-001	325-102.....105-2202-105
3131-18-9.....142-1701-526	01-2310-1.....108-0750-001	9852-0081-6220.....142-1801-636	1464-107.....111-0107-001	325-103.....105-2203-105
3131-20-1.....142-1701-531	01-2312-1.....108-0750-002	9852-0781-6215.....142-1801-606	1483-102.....111-0702-001	325-104.....105-2204-105
3131-20-9.....142-1701-536	01-2341-1-02.....108-0753-102	9852-0781-6215.....142-1801-616	1483-103.....111-0703-001	325-107.....105-2207-105
3131-36-1.....142-1701-541	01-2520-2.....108-2300-501	9852-0781-6220.....142-1801-626	1498-102.....108-2302-621	3502-101.....105-0251-001
3131-36-9.....142-1701-546	01-2540-1-02.....108-0740-102	9852-0781-6220.....142-1801-636	1498-103.....108-2303-621	3502-102.....105-0252-001
3131K-12-1.....142-1701-551	01-2552-1-0210.....108-0253-001	9854-0081-6217.....142-1801-556	1499-102.....108-2302-621	3502-103.....105-0253-001
3131K-12-9.....142-1701-556	01-2552-1-0212.....108-0252-001	9854-0081-6217.....142-1801-566	1499-103.....108-2303-621	359-101.....105-2201-101
3131K-15-1.....142-1701-561	09-9074-1-0310.....105-0203-200	9854-0081-6220.....142-1801-536	1501-101.....105-0201-200	359-102.....105-2202-101
3131K-15-9.....142-1701-566	09-9074-1-0312.....105-0202-200	9854-0081-6227.....142-1801-576	1501-102.....105-0202-200	359-103.....105-2203-101
3131K-18-1.....142-1701-571	09-9074-1-0315.....105-0204-200	9854-0781-6217.....142-1801-556	1501-103.....105-0203-200	359-104.....105-2204-101
3131K-18-9.....142-1701-576	09-9074-1-0316.....105-0210-200	9854-0781-6217.....142-1801-566	1501-104.....105-0204-200	359-107.....105-2207-101
3131K-20-1.....142-1701-581	09-9074-1-0319.....105-0201-200	9854-0781-6220.....142-1801-536	1501-105.....105-0210-200	398-101.....108-2301-801
3131K-20-9.....142-1701-586	09-9126-1-04410.....108-0903-001	9854-0781-6227.....142-1801-576	1502-10X.....105-025X-001	398-102.....108-2302-801
3310-20-1.....142-1801-531	09-9126-1-04411.....108-0908-001	9952-0081-6215.....142-1701-606	1508-101.....108-0901-001	398-103.....108-2303-801
3310-20-9.....142-1801-536	09-9126-1-04412.....108-0902-001	9952-0081-6215.....142-1701-616	1508-102.....108-0902-001	398-104.....108-2304-801
3310-36-1.....142-1801-541	09-9126-1-04413.....108-0906-001	9952-0081-6220.....142-1701-626	1508-103.....108-0903-001	398-105.....108-2310-801
3310-36-9.....142-1801-546	09-9126-1-04414.....108-0907-001	9952-0081-6220.....142-1701-636	1508-104.....108-0904-001	398-107.....108-2307-801
3310K-12-1.....142-1801-551	09-9126-1-04415.....108-0904-001	9952-0081-6236.....142-1701-646	1508-105.....108-0910-001	455-101.....108-0301-001
3310K-12-9.....142-1801-556	09-9126-1-04416.....108-0910-001	9952-0781-6215.....142-1701-606	1508-106.....108-0906-001	455-102.....108-0302-001
3310K-15-1.....142-1801-561	09-9126-1-04417.....108-0912-001	9952-0781-6215.....142-1701-616	1508-107.....108-0907-001	455-103.....108-0303-001
3310K-15-9.....142-1801-566	09-9126-1-04418.....108-0913-001	9952-0781-6220.....142-1701-626	1508-108.....108-0908-001	455-104.....108-0304-001
3310K-18-1.....142-1801-571	09-9126-1-04419.....108-0901-001	9952-0781-6220.....142-1701-636	1508-112.....108-0912-001	455-105.....108-0310-001
3310K-18-9.....142-1801-576	09-9201-1-0310.....105-2203-105	9954-0081-6215.....142-1701-506	1508-113.....108-0913-001	455-106.....108-0306-001
12/1/11.....142-1801-601	09-9201-1-0312.....105-2202-105	9954-0081-6215.....142-1701-516	1509-101.....108-0901-001	455-107.....108-0307-001
12/9/11.....142-1801-606	09-9201-1-0314.....105-2207-105	9954-0081-6217.....142-1701-556	1509-102.....108-0902-001	455-108.....108-0308-001
3311-15-1.....142-1801-611	09-9201-1-0315.....105-2204-105	9954-0081-6217.....142-1701-566	1509-103.....108-0903-001	455-112.....108-0312-001
3311-15-9.....142-1801-616	09-9201-1-0319.....105-2201-105	9954-0081-6220.....142-1701-526	1509-104.....108-0904-001	455-113.....108-0313-001
3311-18-1.....142-1801-621	09-9221-1-0110.....105-0853-001	9954-0081-6220.....142-1701-536	1509-105.....108-0910-001	456-101.....108-0301-001
3311-18-9.....142-1801-626	09-9221-1-0111.....105-0858-001	9954-0081-6227.....142-1701-576	1509-106.....108-0906-001	456-102.....108-0302-001
3311-20-1.....142-1801-631	09-9221-1-0112.....105-0852-001	9954-0081-6227.....142-1701-586	1509-107.....108-0907-001	456-103.....108-0303-001
3311-20-9.....142-1801-636	09-9221-1-0113.....105-0856-001	9954-0081-6236.....142-1701-546	1509-108.....108-0908-001	456-104.....108-0304-001
3311-36-1.....142-1801-641	09-9221-1-0114.....105-0857-001	9954-0781-6215.....142-1701-506	1509-112.....108-0912-001	456-105.....108-0310-001
3311-36-9.....142-1801-646	09-9221-1-0115.....105-0854-001	9954-0781-6215.....142-1701-516	1509-113.....108-0913-001	456-106.....108-0306-001
	09-9221-1-0116.....105-0860-001	9954-0781-6217.....142-1701-556	1513-102.....105-0702-001	456-107.....108-0307-001
	09-9221-1-0119.....105-0851-001	9954-0781-6217.....142-1701-566	1513-103.....105-0703-001	456-108.....108-0308-001
	21-9205-1-0110.....105-0753-001	9954-0781-6220.....142-1701-526	1598-10X.....105-104X-001	456-112.....108-0312-001
	21-9205-1-0111.....105-0758-001	9954-0781-6220.....142-1701-536	1675-10X.....108-025X-001	456-113.....108-0313-001
	21-9205-1-0112.....105-0752-001	9954-0781-6227.....142-1701-576	1677-102.....108-0252-001	457-10X.....108-030X-001
	21-9205-1-0113.....105-0756-001	9954-0781-6227.....142-1701-586	1677-103.....108-0253-001	458-10X.....108-030X-001
	21-9205-1-0114.....105-0757-001		204-102.....108-1702-101	476-10X.....108-030X-001
	21-9205-1-0115.....105-0754-001	HH SMITH EMERSON	204-103.....108-1703-101	477-10X.....108-030X-001
	21-9205-1-0116.....105-0760-001	100.....108-0753-001	205-102.....108-0745-101	478-10X.....108-030X-001
	21-9205-1-0117.....105-0762-001	101.....108-0740-102	205-103.....108-0745-102	479-10X.....108-030X-001
	21-9205-1-0118.....105-0763-001	102.....108-0750-001	210-102.....108-0252-001	491-101.....105-0301-001
	21-9205-1-0119.....105-0751-001	109.....108-0740-001	210-103.....108-0253-001	491-102.....105-0302-001
	21-9205-1-0310.....105-0753-150	121.....108-0754-001	211-102.....108-1722-101	491-103.....105-0303-001
	21-9205-1-0312.....105-0752-150	190.....108-0753-102	211-103.....108-1723-101	491-104.....105-0304-001
	21-9205-1-0314.....105-0757-150	431.....108-0750-001	212-102.....108-1762-101	491-105.....105-0310-001
	21-9205-1-0319.....105-0751-150	433.....108-0750-002	212-103.....108-1763-101	492-101.....105-0301-001
	25-2573-1-0210.....108-0253-001	443.....108-0750-001	219-10X.....108-0745-10X	492-102.....105-0302-001
	25-2573-1-0212.....108-0252-001	445.....108-0750-002	232-10X.....108-176X-101	492-103.....105-0303-001
	BP105B.....111-0103-001	2079.....108-2300-501	242-10X.....108-176X-101	492-104.....105-0304-001
	BP106R.....111-0102-001	1463-101.....111-0101-001	244-102.....105-0772-001	492-105.....105-0310-001
	TJ103R.....105-0202-200	1463-102.....111-0102-001	244-103.....105-0773-001	
	TJ105BL.....105-0203-200	1463-103.....111-0103-001	254-10X.....108-170X-101	HUBER-SUHNER EMERSON
	TJ106GN.....105-0204-200	1463-104.....111-0104-001	261-10X.....108-172X-101	11MCX-50-2-10.....133-3403-001
	TJ107MB.....105-0210-200	1463-105.....111-0110-001	262-10X.....108-176X-101	11MCX-50-1-10.....133-3402-001
	TJ108W.....105-0201-200	1463-107.....111-0107-001	268-102.....108-1002-001	11MCX-50-2-3.....133-3693-001
		1464-101.....111-0101-001	268-103.....108-1003-001	11MMCX-50-1-1.....135-3402-001
	DYNAWAVE.....EMERSON	1464-102.....111-0102-001	271-10X.....108-172X-101	11MMCX-50-1-2.....135-3436-001
	9852-0081-6215.....142-1801-606	1464-103.....111-0103-001	281-10X.....108-172X-101	11SMA-50-2-42.....142-0403-011
	9852-0081-6215.....142-1801-616	1464-104.....111-0104-001	325-101.....105-2201-105	11SMA-50-2-65.....142-0693-001

Competitor Cross Reference

11SMA-50-3-42.....	142-0694-031	85 MCX-50-0-1.....	133-3701-301	6064.....	105-2204-105	2025-6-9-MO6.....	CPMC-78-2	KC-59-300.....	CPMC-88-3
11SMA-50-3-64.....	142-0694-011	85MMCX-50-0-1.....	135-3701-301	6066.....	105-2201-101	2025-7-9.....	CPMC-78-3	KC-59-303.....	CPMC-88-13
11SMA-50-3-65.....	142-0694-001	85SMA-50-0-44.....	142-0701-301	6067.....	105-2202-101	2029-16-5.....	CP-AD705	KC-59-306.....	CPMC-88-18
11SMB-50-2-13.....	131-3693-001	85SMB-50-0-1.....	131-1701-371	6068.....	105-2203-101	2029-16-9.....	CP-AD705	KC-59-307.....	CPMC-88-18
11SMB-50-1-10.....	131-3402-001	85SMC-50-0-1/111.....	131-6701-301	6069.....	105-2207-101	2029-17-9.....	CP-AD557	KC-59-346.....	CPMC-88-13
11SMC50-2/10/111.....	131-6403-001	86SMC-50-2-2.....	142-0003-301	6070.....	105-2204-101	2029-3-5.....	CP-AD705	KC-59-347.....	CPMC-88-1
16MCX-50-1-5.....	133-3402-101	KEYSTONE..... EMERSON		6072.....	108-0753-001	2065-1-9.....	CPMC-68-2	KC-59-348.....	CPMC-88-1
16MCX-50-25/111.....	133-3403-101	6000.....	105-0301-001	6076.....	108-1002-001	2065-2-9.....	CPMC-68-35	KC-59-362.....	CPMC-88-19
16MCX-50-25/133.....	133-3403-106	6001.....	105-0302-001	6077.....	108-1003-001	2065-3-9.....	CPMC-68-50	KC-59-397.....	CPMC-88-2
16MCX-50-2-3.....	133-3693-101	6002.....	105-0302-001	6078.....	108-0302-001	2065-5-9.....	CPMC-68-20	KC-59-399.....	CPMC-88-13
16MMCX-50-1-1.....	135-3402-101	6003.....	105-0303-001	6079.....	108-0303-001	2065-6-9.....	CPMC-68-3	KC-59-400.....	CPMC-88-1
16MMCX-50-1-2.....	135-3436-101	6005.....	105-0304-001	6080.....	108-1762-101	2065-7-9.....	CPMC-68-2	KC-59-414.....	CPMC-88-1
16MMCX-50-2-1.....	135-3693-101	6006.....	105-0310-001	6081.....	108-1763-101	2065-10-9.....	CPMC-68-36	KC-59-414-MO6.....	CPMC-88-1
16MMCX-50-2-4.....	135-3403-101	6006.....	105-0771-001	6082.....	108-1762-101	2065-10-9.....	CPMC-68-45	KC-59-415.....	CPMC-88-12
16MMCX-50-2-6.....	135-3404-101	6007.....	105-0772-001	6083.....	108-1763-101	2065-11-9.....	CPMC-68-34	KC-59-416.....	CPMC-88-14
16SMA-50-2-45.....	142-0403-101	6008.....	105-0773-001	6084.....	108-1702-101	759-1.....	CP-AD555	KC-59-416-MO6.....	CPMC-88-14
16SMA-50-2-3.....	142-0693-101	6012.....	105-0201-200	6085.....	108-1703-101	759-3.....	CP-AD505	KC-59-417.....	CPMC-88-13
16SMA-50-2-3.....	142-0694-101	6013.....	105-0202-200	6088.....	108-0252-001	759-4.....	CP-AD503	KC-59-417-MO6.....	CPMC-88-13
16SMB-50-1-20.....	131-1402-101	6014.....	105-0203-200	6089.....	108-0253-001	759-5.....	CP-AD511	KC-59-421.....	CPMC-88-1
16SMB-50-2-20.....	131-1403-101	6015.....	105-0204-200	6091.....	108-0902-001	879-11-15-MA9.....	CP-AD507	KC-59-422.....	CPMC-88-13
16SMC-50-2-20.....	131-6403-101	6017.....	105-0210-200	6092.....	108-0903-001	879-5-15-MA9.....	CP-AD508	KC-59-423.....	CPMC-88-1
21MCX-50-1-10.....	133-3302-001	6018.....	105-0801-001	6093.....	108-0745-001	KA-59-103.....	CPMC-TNC-1	KC-59-465.....	CPMC-88-2
21MCX-50-2-10.....	133-3303-001	6019.....	105-0802-001	6094.....	108-0745-002	KA-59-225.....	CPMC-TNC-1	KC-59-482.....	CPMC-88-2
21MMCX-50-1-1.....	135-3302-001	6020.....	105-0803-001	6095.....	108-0740-102	KA-59-230.....	CPMC-TNC-13	KC-59-61.....	CPMC-88-1
21MMCX-50-1-2.....	135-3303-001	6021.....	105-0804-001	7004.....	111-0102-001	KA-59-231.....	CPMC-TNC-1	KC-59-616-MO6.....	CPMC-88-3
22MCX-50-0-2.....	133-3701-401	6022.....	105-0807-001	7005.....	111-0103-001	KA-59-232.....	CPMC-TNC-2	KC-59-632-MO6.....	CPMC-88-1
22SMA-50-0-44.....	142-0701-401	6023.....	105-0810-001	7006.....	111-0702-001	KA-59-263.....	CPMC-TNC-2	KC-59-655-MO6.....	CPMC-88-14
22SMB-50-0-11.....	131-3701-421	6024.....	105-0251-001	7007.....	111-0703-001	KA-59-265.....	CPMC-TNC-1	KC-59-78.....	CPMC-88-1
22SMB-50-0-2.....	131-3701-411	6025.....	105-0252-001	552-4.....	108-0754-001	KA-59-287.....	CPMC-TNC-1	KC-59-79.....	CPMC-88-1
22SMB-50-0-3.....	131-3701-401	6026.....	105-0253-001	6074-1.....	108-0750-001	KA-59-292.....	CPMC-TNC-13	KC-59-80.....	CPMC-88-13
22SMC-50-0-2.....	131-6701-411	6030.....	105-0601-001	6074-2.....	108-0750-002	KA-59-385-MO6.....	CPMC-TNC-2	KC-59-95.....	CPMC-88-19
22SMC-50-0-3.....	131-6701-401	6031.....	105-0602-001	872-1.....	142-0594-401	KA-59-406-MO6.....	CPMC-TNC-1	KC-59-98.....	CPMC-88-1
23SMA-50-0-41.....	142-0701-621	6032.....	105-0603-001	872-11.....	142-0302-401	KA-59-44.....	CPMC-TNC-1	KC-79-106.....	CP-1094-U
23SMA-50-0-44.....	142-0701-631	6033.....	105-0604-001	872-12.....	142-0303-401	KA-59-45.....	CPMC-TNC-13	KC-79-109.....	CP-1094-U
23SMA-50-0-120.....	142-1701-201	6034.....	105-0607-001	872-8.....	142-0593-401	KA-59-46.....	CPMC-TNC-2	KC-79-109.....	CP-AD519
23SMA-50-0-122.....	142-1701-191	6035.....	105-0610-001	873-4.....	142-0594-001	KA-59-57.....	CPMC-TNC-13	KC-79-121.....	CP-1094-U
23SMA-50-0-170.....	142-1701-206	6036.....	105-0851-001	873-9.....	142-0593-001	KA-59-69.....	CPM-TNC-19	KC-79-123.....	CP-AD519
23SMA-50-0-172.....	142-1701-196	6037.....	105-0852-001	874-1.....	142-0701-401	KA-59-86.....	CPMC-TNC-13	KC-79-131.....	CP-1094-U
24MCX-50-1-10.....	133-3302-401	6038.....	105-0853-001	874-5.....	142-0701-411	KA-59-94.....	CPMC-TNC-2	KC-79-132.....	CP-AD519
24MCX-50-1-10.....	133-3303-401	6039.....	105-0857-001	875-10-M09.....	142-0693-001	KA-91-01.....	CP-AD355	KC-79-35.....	CP-1094-U
24SMA-50-2-41.....	142-0593-401	6040.....	105-0854-001	875-13.....	142-0403-001	KA-91-05.....	CP-AD306	KC-79-46.....	CP-1094-U
24SMA-50-3-41.....	142-0594-401	6041.....	105-0860-001	875-4-M09.....	142-0694-031	KA-91-09.....	CP-AD355	KC-99-20.....	CP-AD506
24SMC50-2/10C/111.....	131-6303-401	6042.....	105-2201-201	875-8-M09.....	142-0694-001	KA-91-18.....	CP-AD300	KC-99-30.....	CP-AD555
27SMA-50-0-1.....	142-0701-531	6043.....	105-2202-201	876-1.....	142-0407-101	KA-99-114-MO6.....	CP-AD356	KC-99-31.....	CP-AD505
27SMA-50-0-51.....	142-0701-536	6044.....	105-2203-201	876-6.....	142-0403-101	KA-99-59.....	CP-AD300	KC-99-32.....	CP-AD511
28SMA-50-0-1.....	142-0701-701	6045.....	105-2207-201	877-1.....	142-0701-631	KA-99-62.....	CP-AD355	KC-99-33.....	CP-AD556
28SMA-50-0-51.....	142-0701-706	6046.....	105-2204-201	877-2.....	142-0701-621	KC-59-104.....	CPMC-88-13	KC-99-34.....	CP-AD500
31MCX-50-0-1.....	133-3901-801	6048.....	105-1101-001	877-21.....	142-0701-301	KC-59-107.....	CPMC-88-12	KC-99-35.....	CP-AD503
34SMB-50-0-2.....	131-3901-401	6049.....	105-1102-001	879-13.....	142-0901-401	KC-59-115.....	CPMC-88-13	KC-99-37.....	CP-AD506
81MCX-50-0-1.....	133-3801-201	6050.....	105-1103-001	879-2-M09.....	142-0901-811	KC-59-116.....	CPMC-88-13	KC-99-40.....	CP-AD521
81MMCX-50-0-1.....	135-3801-201	6051.....	105-1107-001	879-3.....	142-0901-801	KC-59-123.....	CPMC-88-1	KC-99-42.....	CP-AD500
81SMB-50-0-1/111.....	131-3801-201	6052.....	105-1104-001	KINGS..... EMERSON		KC-59-128.....	CPMC-88-2	KC-99-44.....	CP-AD555
82MCX-50-0-1/111.....	133-3701-201	6053.....	105-1110-001	1209-1-15-MA9.....	CP-AD810	KC-59-152.....	CPMC-88-19	KC-99-52.....	CP-AD505
82MCX-50-0-1/133.....	133-3701-206	6054.....	105-0751-001	1209-10.....	CP-AD803	KC-59-162.....	CPMC-88-13	KC-99-54.....	CP-AD521
82MCX-50-0-10.....	133-3701-231	6055.....	105-0752-001	1209-13.....	CP-AD850	KC-59-167.....	CPMC-88-13	KC-99-56.....	CP-AD511
82MCX-50-0-2.....	133-3701-201	6056.....	105-0753-001	1209-18.....	CP-AD807	KC-59-180.....	CPMC-88-3	KC-99-64.....	CP-AD505
82MMCX-50-0-1.....	135-3701-201	6057.....	105-0757-001	1209-7.....	CP-AD809	KC-59-181.....	CPMC-88-3	KC-99-95-MO6.....	CP-AD556
82SMA-50-0-41.....	142-0701-201	6058.....	105-0754-001	2025-36-9.....	CPMC-78-2	KC-59-223.....	CPMC-88-18	KN-59-132.....	CPN-8
82SMB-50-0-1/111.....	131-1701-201	6059.....	105-0760-001	2025-37-9.....	CPMC-78-3	KC-59-279.....	CPMC-88-13	KN-59-204-MO6.....	CPN-1
82SMC-50-0-1.....	131-6701-201	6060.....	105-2201-105	2025-44-9.....	CPMC-68-33	KC-59-290.....	CPMC-88-1	KN-59-207.....	CP-AD802
83MCX-0-2-5.....	142-0003-231	6061.....	105-2202-105	2025-51-9.....	CPMC-78-2	KC-59-291.....	CPMC-88-1	KN-59-273-MO6.....	CPN-2
83SMC-0-2-2.....	142-0003-201	6062.....	105-2203-105	2025-59-9.....	CPMC-78-2	KC-59-293.....	CPMC-88-1	KN-99-35.....	CP-AD809
84SMB-50-0-1.....	131-1801-371	6063.....	105-2207-105			KC-59-294.....	CPMC-88-2	KN-99-36.....	CP-AD809

KN-99-44.....CP-AD800	73327-1212.....142-0103-401	20-2500-1200G.....142-0207-101	R113311.....133-3304-401	RETCONN.....EMERSON
KN-99-46.....CP-AD807	73333-5002.....142-0701-631	20-2800-0400G.....142-0402-101	R113311020.....133-3304-406	350-060-0040H.....142-0801-201
KN-99-50.....CP-AD850	73334-5002.....142-0701-621	20-2800-0670G.....142-0403-101	R113426.....133-3701-201	350-060-0040N.....142-0801-206
KN-99-69.....CP-AD803	73352-5002.....142-0701-401	20-2800-1200G.....142-0407-101	R113426020.....133-3701-206	350-700-0360H.....142-0202-011
KU-59-22.....CP-AD250	73355-5002.....142-0901-811	20-3450-00G.....142-0701-301	R113427.....133-3701-231	350-700-0360N.....142-0202-016
KU-59-35.....CPL-259-2	73356-5002.....142-0901-821	20-3450-65G.....142-0701-501	R113427020.....133-3701-236	350-700-0630H.....142-0203-011
KU-59-48.....CPL-259-8	73357-5002.....142-0901-801	2020-0000-00G.....142-0901-811	R113553.....133-3701-401	350-700-0630N.....142-0203-016
KU-59-53.....CPL-259-1	73359-5002.....142-0901-401	2020-0100-00G.....142-0901-821	R113553020.....133-3701-406	350-700-1161H.....142-0207-011
KU-99-08.....CP-AD250	73446-1212.....133-3403-001	2020-1100-00G.....142-0901-801	R113665.....133-3701-301	350-700-1161N.....142-0207-016
PL-259.....CP-AD250	73446-1412.....133-3402-001	2020-1165-00G.....142-0901-401	R113665020.....133-3701-306	350-800-0630H.....142-0403-001
UG-224/U.....CP-AD207	73447-1212.....133-3403-101	32-2800-0400.....135-3402-101	R113704.....133-3901-801	350-800-0630N.....142-0403-006
UG-57 B/U.....CP-AD800	73447-1412.....133-3402-101	32-2800-0670.....135-3403-101	R113704020.....133-3901-806	350-900-0630H.....142-0403-011
UG-914/U.....CP-AD555	73448-1922.....133-3693-101	32-2800-2670.....135-3404-101	R114-237.....131-3302-001	350-900-0630N.....142-0403-016
	73452-1212.....133-3303-001	33-0900-0400.....135-3402-001	R114053.....131-3693-001	350-900-0631H.....142-0404-011
MA/COM.....SEETCYO/AMP	73453-5002.....133-3701-301	33-0900-0670.....135-3403-001	R114073134.....131-3402-001	350-900-0631N.....142-0404-016
MOLEX.....EMERSON	73454-5002.....133-3701-231	33-0900-2670.....135-3404-001	R114073134.....131-3402-001	350-900-1160H.....142-0407-011
73301-1812.....142-0694-001	73455-5002.....133-3701-201	33-1442-00.....135-3701-201	R114075134.....131-3403-001	350-900-1160N.....142-0407-016
73301-1912.....142-0693-001	73457-5002.....133-3701-401	33-1486-00.....135-3711-801	R114075134.....131-3403-001	350-900-1161H.....142-0408-011
73303-1812.....142-0594-001	PHOENIX.....EMERSON	33-2200-086.....135-3693-101	R114082.....131-1403-001	350-900-1161N.....142-0408-016
73303-1912.....142-0593-001	09-0450-00.....131-3801-201	POMONA.....EMERSON	R114169.....131-1693-101	351-060-0040H.....142-1701-201
73304-1812.....142-0594-401	09-0800-677.....131-1403-001	3259.....108-0754-001	R114183.....131-1402-101	351-060-0040N.....142-1701-206
73304-1912.....142-0593-401	09-1080-00.....131-3701-401	3263.....108-0750-001	R114186.....131-1402-101	351-065-0000H.....142-0701-631
73312-1212.....142-0403-001	09-1080-01.....131-3701-411	4511.....108-0750-002	R114222.....131-3593-401	351-065-0000N.....142-0701-636
73313-1122.....142-0407-101	09-1450-04.....131-3701-201	1581-0.....108-2303-621	R114237.....131-3302-001	351-066-0000H.....142-0701-621
73313-1222.....142-0403-101	09-2800-0400.....131-1402-101	1581-2.....108-2302-621	R114238.....131-3303-001	351-066-0000N.....142-0701-626
73314-1112.....142-0207-011	09-2800-0670.....131-1403-101	RADIALL.....EMERSON	R114239.....131-3303-001	351-066-0040H.....142-1701-131
73314-1212.....142-0203-011	09-2800-2670.....131-1404-101	R112075.....131-6403-001	R114426.....131-1701-201	351-066-0040N.....142-1701-136
73315-1122.....142-0207-101	09-3450-00.....131-1701-371	R112186.....131-6403-101	R114553.....131-3701-411	351-075-0001H.....142-0701-401
73315-1222.....142-0203-101	0909-1180-00.....131-3901-401	R112307.....131-6303-401	R114554.....131-3701-401	351-075-0001N.....142-0701-406
73324-1212.....142-0303-401	10-0800-0670.....131-6403-001	R112426.....131-6701-201	R114566.....131-3701-421	351-075-0002H.....142-0701-411
73327-1212.....142-0103-401	10-0800-2670.....131-6404-001	R112553.....131-6701-411	R114665.....131-1701-371	351-075-0002N.....142-0701-416
73333-5002.....142-0701-631	10-1080-00.....131-6701-401	R112554.....131-6701-401	R114720.....131-3901-401	351-875-0360H.....142-0302-401
73334-5002.....142-0701-621	10-1080-01.....131-6701-411	R112665.....131-6701-301	R125052.....142-0693-001	351-875-0360N.....142-0302-406
73352-5002.....142-0701-401	10-1450-00.....131-6701-201	R113053.....133-3693-001	R125054.....142-0694-031	351-875-0630H.....142-0303-401
73355-5002.....142-0901-811	10-2800-0670.....131-6403-101	R113053020.....133-3693-006	R125055.....142-0694-001	351-875-0630N.....142-0303-406
73356-5002.....142-0901-821	10-3450-0.....131-6701-301	R113081.....133-3402-001	R125072.....142-0403-011	351-875-1161H.....142-0308-401
73357-5002.....142-0901-801	13-0200-0860.....133-3693-001	R113081020.....133-3402-006	R125072001.....142-0403-016	351-875-1161N.....142-0308-406
73359-5002.....142-0901-401	13-0450-00.....133-3801-201	R113082.....133-3403-001	R125072008.....142-0404-011	351-900-0630H.....142-0303-011
73446-1212.....133-3403-001	13-0900-0400.....133-3402-001	R113082020.....133-3403-006	R125073.....142-0403-001	351-900-0630N.....142-0303-016
73446-1412.....133-3402-001	13-0900-0670.....133-3403-001	R113083.....133-3404-001	R125075.....142-0407-011	351-900-0631H.....142-0304-011
73447-1212.....133-3403-101	13-0900-2670.....133-3404-001	R113083020.....133-3404-006	R125075001.....142-0407-016	351-900-0631N.....142-0304-016
73447-1412.....133-3402-101	13-1450-00.....131-3701-201	R113153.....133-3693-101	R125076.....142-0408-011	351-900-1160H.....142-0307-011
73448-1922.....133-3693-101	13-1900-0400.....133-3302-001	R113153020.....133-3693-106	R125076001.....142-0408-016	351-900-1160N.....142-0307-016
73452-1212.....133-3303-001	13-1900-0670.....133-3303-001	R113181.....133-3402-101	R125091.....142-0203-011	351-900-1161H.....142-0308-011
73453-5002.....133-3701-301	13-1900-2670.....133-3304-001	R113182020.....133-3402-106	R125172.....142-0403-101	351-900-1161N.....142-0308-016
73454-5002.....133-3701-231	13-2200-0860.....133-3693-101	R113183.....133-3404-101	R125175.....142-0407-101	351-975-0630H.....142-0303-411
73455-5002.....133-3701-201	13-2800-0670.....133-3403-101	R11318320.....133-3404-106	R125222.....142-0593-001	351-975-0630N.....142-0303-416
73457-5002.....133-3701-401	20-1265-1410G.....142-0594-401	R113236.....133-3302-001	R125225.....142-0594-001	351-975-0631H.....142-0304-411
73301-1812.....142-0694-001	20-1464-00G.....142-0701-411	R113236020.....133-3302-006	R125237001.....142-0307-016	351-975-0631N.....142-0304-416
73301-1912.....142-0693-001	20-1565-0400G.....142-0102-401	R113240.....133-3303-001	R125238.....142-0308-011	351-975-1160H.....142-0307-411
73303-1812.....142-0594-001	20-1565-0670G.....142-0103-401	R113240020.....133-3303-006	R125238001.....142-0308-016	351-975-1160N.....142-0307-416
73303-1912.....142-0593-001	20-1865-0402G.....142-0302-401	R113241.....133-3304-001	R125325.....142-0594-401	351-975-1161H.....142-0308-411
73304-1812.....142-0594-401	20-1865-672G.....142-0303-401	R113241020.....133-3304-006	R125326.....142-0593-401	351-975-1161N.....142-0308-416
73304-1912.....142-0593-401	20-2200-0860G.....142-0693-101	R113280280100.....142-0003-231	R125403.....142-0701-631	352-060-0040H.....142-0801-301
73312-1212.....142-0403-001	20-2200-1410G.....142-0694-101	R113280280120.....142-0003-236	R125553.....142-0701-401	352-060-0040N.....142-0801-306
73313-1122.....142-0407-101	20-2450-00G.....142-0801-301	R113306.....133-3302-401	R125560.....142-0701-411	352-700-0360H.....142-0202-101
73313-1222.....142-0403-101	20-2500-0400G.....142-0202-101	R113306020.....133-3302-406	R125680.....142-0701-301	352-700-0360N.....142-0202-106
73314-1112.....142-0207-011	20-2500-0670G.....142-0203-101	R113310.....133-3303-401	R125703.....142-0901-811	352-700-0630H.....142-0203-101
73314-1212.....142-0203-011		R113310020.....133-3303-406	R125704.....142-0901-821	352-700-0630N.....142-0203-106
73315-1122.....142-0207-101			R125705.....142-0901-801	352-700-1161H.....142-0207-101
73315-1222.....142-0203-101			R125720.....142-0901-401	352-700-1161N.....142-0207-106
73324-1212.....142-0303-401				352-900-0630H.....142-0403-101
				352-900-0630N.....142-0403-106

For more information, please contact customer service at (507) 833-8822 or (800) 247-8256 • cinch.com

Competitor Cross Reference

352-900-0631H.....142-0404-101	29 K 203-400 D3.....133-3701-301	50-672-0000-31.....142-0901-801	39JR295-3.....142-1701-526	2950-6781.....142-1701-641
352-900-0631N.....142-0404-106	29 K 501-101 A3.....133-3302-406	50-673-0000-31.....142-0901-811	39JR295-4.....142-1701-536	2950-6784.....142-1701-621
352-900-1160H.....142-0407-101	29 K 501-101 D3.....133-3302-401	50-674-0000-31.....142-0901-821	39JR295-5.....142-1701-546	2950-6784.....142-1701-631
352-900-1160N.....142-0407-106	29 K 501-102 A3.....133-3303-406	50-675-0000-31.....142-0901-401	39JR296-1.....142-1701-606	2950-6786.....142-1701-601
352-900-1161H.....142-0408-101	29 K 501-102 D3.....133-3303-401	51-024-0000.....131-1403-001	39JR296-2.....142-1701-616	2950-6789.....142-1701-521
352-900-1161N.....142-0408-106	29 K 501-103 A3.....133-3304-406	51-024-0000.....131-3403-001	39JR296-3.....142-1701-626	2950-6789.....142-1701-531
353-060-0040H.....142-0701-301	29 K 501-103 D3.....133-3304-401	51-024-3196.....131-3402-001	39JR296-4.....142-1701-636	2951-6106.....142-1701-551
353-060-0040N.....142-0701-306	29 K 501-500 A3.....133-3701-406	51-025-0000.....131-3303-001	39JR296-5.....142-1701-646	2951-6107.....142-1701-571
450-060-0046H.....133-3801-201	29 K 501-500 D3.....133-3701-401	51-025-3196.....131-3302-001	39PR130-4.....142-1801-536	2951-6107.....142-1701-581
450-060-0046N.....133-3801-206	29 S 101-101 A3.....133-3402-006	51-043-0000.....131-3701-401	39PR130-5.....142-1801-546	2951-6110.....142-1701-611
450-500-0850H.....133-3693-001	29 S 101-101 D3.....133-3402-001	51-045-0000.....131-3701-411	39PR131-1.....142-1801-606	2951-6112.....142-1701-561
450-500-0850N.....133-3693-006	29 S 101-102 A3.....133-3403-006	51-045-4504.....131-3701-631	39PR131-2.....142-1801-616	2951-6114.....142-1701-551
450-900-0360H.....133-3402-001	29 S 101-102 D3.....133-3403-001	51-045-4524.....131-3701-621	39PR131-3.....142-1801-626	2951-6115.....142-1701-571
450-900-0360N.....133-3402-006	29 S 101-103 A3.....133-3404-006	51-049-0000.....131-3701-421	39PR131-4.....142-1801-636	2951-6115.....142-1701-581
450-900-0630H.....133-3403-001	29 S 101-103 D3.....133-3404-001	51-051-0000.....131-1701-201	39PR131-5.....142-1801-646	2951-6116.....142-1701-591
450-900-0630N.....133-3403-006	29 S 101-271 A3.....133-3693-006	51-051-0000.....131-3701-201	39PR132-4.....142-1801-536	2951-6122.....142-1701-611
450-900-0631H.....133-3404-001	29 S 101-271 D3.....133-3693-001	51-052-0000.....131-3801-201	39PR132-5.....142-1801-546	2951-6124.....142-1701-561
450-900-0631N.....133-3404-006	29 S 201-271 A3.....133-3693-106	51-053-0000.....131-1701-371	39PR133-1.....142-1801-606	2951-6125.....142-1701-511
451-060-0046H.....133-3701-201	29 S 201-271 D3.....133-3693-101	51-053-0000.....131-3701-301	39PR133-2.....142-1801-616	2951-6146.....142-1701-511
451-060-0046N.....133-3701-206	29 S 201-301 A3.....133-3402-106	51-054-0000.....131-3801-301	39PR133-3.....142-1801-626	2955-6166.....142-1801-541
451-061-0040H.....133-3711-201	29 S 201-301 D3.....133-3402-101	51-062-2210.....131-3701-801	39PR133-4.....142-1801-636	2955-6177.....142-1801-601
451-451-0000H.....133-3901-801	29 S 201-302 A3.....133-3403-106	51-075-0000.....131-3901-401	39PR133-5.....142-1801-646	2955-6178.....142-1801-531
451-451-0000N.....133-3901-806	29 S 201-302 D3.....133-3403-101	51-328-3188.....131-1403-101		2955-6197.....142-1801-621
451-900-0360H.....133-3302-001	29 S 201-303 A3.....133-3404-106	51-328-3188.....131-3403-101	SRI.....EMERSON	2955-6197.....142-1801-631
451-900-0360N.....133-3302-006	29 S 201-303 D3.....133-3404-101	51-328-3196.....131-1402-101	24-000-1041-90.....145-0694-002	2955-6297.....142-1801-531
451-900-0630H.....133-3303-001	29 Z 101-102 A3.....142-0003-236	51-328-3196.....131-3402-101	24-924-0000-90.....145-0901-811	2955-6298.....142-1801-601
451-900-0630N.....133-3303-006	29 Z 101-102 D3.....142-0003-231	55-607-0369-31.....142-0694-031	24-925-0000-90.....145-0901-821	2955-6299.....142-1801-621
451-900-0631H.....133-3304-001	29 Z 101-103 A3.....142-0004-216	55-607-2203-31.....142-0694-001	25-130-1500-90.....145-0701-602	2955-6299.....142-1801-631
451-900-0631N.....133-3304-006	29 Z 101-103 D3.....142-0004-211	55-607-3702-31.....142-0693-001	25-131-1500-90.....145-0701-612	2955-6300.....142-1801-641
451-980-0360H.....133-3302-401		55-607-9073-31.....142-0694-011	25-925-0000-90.....145-0901-801	2955-6305.....142-1801-611
451-980-0360N.....133-3302-406	SEALECTRO.....EMERSON	55-607-9172-31.....142-0693-001	26-000-1085-90.....145-0693-002	2955-6333.....142-1801-611
451-980-0630H.....133-3303-401	50-024-0000.....131-6403-001	55-607-9173-31.....142-0694-001		2960-6001.....142-0701-701
451-980-0630N.....133-3303-406	50-027-0000.....131-6303-401	55-608-2002-31.....142-0593-001	SV MICROWAVE.....EMERSON	2960-6025.....142-1711-001
451-980-0631H.....133-3304-401	50-043-0000.....131-6701-401	55-608-2003-31.....142-0594-001	066-15-000.....142-1000-033	2960-6268.....142-1711-021
451-980-0631N.....133-3304-406	50-045-0000.....131-6701-411	55-608-9182-31.....142-0593-001	2902-6001.....142-0694-031	2960-6274.....142-1711-031
452-500-0850H.....133-3693-101	50-051-0000.....131-6701-201	55-608-9183-31.....142-0594-001	2902-6005.....142-0694-001	2960-6613.....142-1711-531
452-500-0850N.....133-3693-106	50-053-0000.....131-6701-301	55-610-3702-31.....142-0593-401	2902-6012.....142-0694-001	2960-6701.....142-1711-521
452-900-0360H.....133-3402-101	50-328-3188.....131-6403-101	55-610-3703-31.....142-0594-401	2902-6013.....142-0694-021	2960-6703.....142-1711-511
452-900-0360N.....133-3402-106	50-607-3141-31.....142-0207-011	55-610-9172-31.....142-0594-401	2903-6009.....142-0403-001	2970-6003.....142-0701-401
452-900-0630H.....133-3403-101	50-607-3188-31.....142-0203-011	55-610-9173-31.....142-0594-401	2906-6002.....142-0693-001	2975-6001.....142-0701-411
452-900-0630N.....133-3403-106	50-607-3196-31.....142-0202-011	55-624-3073-31.....142-0694-021	2911-6001.....142-0407-101	2990-6005.....142-0901-401
452-900-0631H.....133-3404-101	50-610-3188-31.....142-0103-401		2913-6001.....142-0403-101	2992-6001.....142-0901-801
452-900-0631N.....133-3404-106	50-610-3196-31.....142-0102-401	SIEMENS.....EMERSON	2913-6030.....142-0402-101	2993-6001.....142-0901-811
453-060-0046H.....133-3701-301	50-611-3141-31.....142-0207-101	V23608-A1027-B1.....135-3701-201	2921-6002.....142-0593-001	2997-6003.....142-0901-821
453-060-0046N.....133-3701-306	50-611-3188-31.....142-0203-101	V23608-A109-B1.....135-3402-001	2922-6007.....142-0594-001	SF1503-6103.....145-0693-002
	50-611-3196-31.....142-0202-101	V23608-A109-B11.....135-3436-001	2942-6001.....142-0594-401	SF1550-6400.....145-0701-612
ROSENBERGER.....EMERSON	50-622-9141-31.....142-0407-011	V23608-A1227-B1.....135-3701-301	2942-6035.....142-0303-401	SF1552-6002.....145-0701-602
02-K-521-800S3.....145-0701-002	50-622-9142-31.....142-0408-011	V23608-A209-B1.....135-3402-101	2943-6044.....142-0302-401	SF1590-6000.....145-0901-801
02-S-121-271S3.....142-0693-002	50-622-9188-31.....142-0403-011	V23608-A209-B11.....135-3436-101	2946-6001.....142-0593-401	SF1593-6000.....145-0901-811
02-Z-101-000.....142-1000-033	50-624-9188-31.....142-0403-001		2947-6003.....142-0701-531	SF1597-6003.....145-0901-821
29 K 100-K00 D3.....133-3901-801	50-627-9188-31.....142-0303-401	SPECIALTY.....EMERSON	2950-6062.....142-0701-621	SF2947-6003.....142-0701-536
29 K 101-101 A3.....133-3302-006	50-627-9196-31.....142-0302-401	39JR293-1.....142-1701-506	2950-6081.....142-0701-631	SF2950-6135.....142-1701-196
29 K 101-101 D3.....133-3302-001	50-628-9141-31.....142-0407-101	39JR293-2.....142-1701-516	2950-6135.....142-1701-191	SF2950-6220.....142-1701-016
29 K 101-102 A3.....133-3303-006	50-628-9188-31.....142-0403-101	39JR293-3.....142-1701-526	2950-6220.....142-1701-011	SF2950-6336.....142-1701-206
29 K 101-102 D3.....133-3303-001	50-628-9196-31.....142-0402-101	39JR293-4.....142-1701-536	2950-6336.....142-1701-201	SF2950-6619.....142-1701-506
29 K 101-103 A3.....133-3304-006	50-643-0000-31.....142-0701-401	39JR293-5.....142-1701-546	2950-6619.....142-1701-501	SF2950-6662.....142-1701-526
29 K 101-103 D3.....133-3304-001	50-643-4312-31.....142-0701-411	39JR294-1.....142-1701-606	2950-6662.....142-1701-521	SF2950-6662.....142-1701-536
29 K 101-400 A3.....133-3701-206	50-645-4504-31.....142-0701-631	39JR294-2.....142-1701-616	2950-6662.....142-1701-531	SF2950-6720.....142-1701-606
29 K 101-400 D3.....133-3701-201	50-645-4526-31.....142-0701-621	39JR294-3.....142-1701-626	2950-6720.....142-1701-601	SF2950-6731.....142-1701-546
29 K 101-K00 A3.....133-3901-806	50-651-0000-31.....142-0701-201	39JR294-4.....142-1701-636	2950-6731.....142-1701-541	SF2950-6769.....142-1701-506
29 K 104-400 A3.....133-3701-236	50-652-0000-31.....142-0801-201	39JR294-5.....142-1701-646	2950-6769.....142-1701-501	SF2950-6780.....142-1701-626
29 K 104-400 D3.....133-3701-231	50-653-0000-31.....142-0701-301	39JR295-1.....142-1701-506	2950-6780.....142-1701-621	SF2950-6780.....142-1701-636
29 K 203-400 A3.....133-3701-306	50-654-0000-31.....142-0801-301	39JR295-2.....142-1701-516	2950-6780.....142-1701-631	SF2950-6781.....142-1701-646

SF2950-6784.....142-1701-626	J01270A002 1.....133-3403-001	2-227079-0.....CPM-88-20	2052-3358-00.....142-1701-541	2831-7341-02.....142-0408-016
SF2950-6784.....142-1701-636	J01270A002 9.....133-3403-006	2-227079-1.....CPM-88-20	2052-3358-02.....142-1701-546	2831-7358-02.....142-0407-016
SF2950-6786.....142-1701-606	J01270A005 1.....133-3402-101	2-227079-2.....CPM-88-20	2052-3359-00.....142-1701-641	2831-7388-02.....142-0403-016
SF2950-6789.....142-1701-526	J01270A005 9.....133-3402-106	2-331350-1.....CPMC-88-1	2052-3359-02.....142-1701-646	2834-7316-02.....142-0304-416
SF2950-6789.....142-1701-536	J01270A006 1.....133-3403-101	2-331350-2.....CPMC-88-18	2052-3362-00.....142-1701-531	2834-7341-02.....142-0308-416
SF2951-6106.....142-1701-556	J01270A006 9.....133-3403-106	2-331350-4.....CPM-88-19	2052-3362-02.....142-1701-536	2834-7358-02.....142-0307-416
SF2951-6107.....142-1701-576	J01270A009 1.....133-3693-101	2-331350-5.....CPM-88-20	2052-3363-00.....142-1701-631	2834-7388-02.....142-0303-416
SF2951-6107.....142-1701-586	J01270A009 9.....133-3693-106	2-331350-6.....CPMC-88-14	2052-3363-02.....142-1701-636	2837-7316-02.....142-0404-106
SF2951-6110.....142-1701-616	J01271A000 1.....133-3302-001	2-331350-9.....CPMC-88-13	2052-3375-00.....142-1701-571	2837-7341-02.....142-0408-106
SF2951-6112.....142-1701-566	J01271A000 9.....133-3302-006	2001-5003-00.....142-0694-001	2052-3375-02.....142-1701-576	2837-7358-02.....142-0407-106
SF2951-6114.....142-1701-556	J01271A010 1.....133-3701-401	2001-5025-00.....142-0694-021	2052-3393-00.....142-1701-551	2837-7388-02.....142-0403-106
SF2951-6115.....142-1701-576	J01271A010 9.....133-3701-406	2001-5031-00.....142-0694-011	2052-3393-02.....142-1701-556	4801-7985-02.....145-0693-002
SF2951-6115.....142-1701-586	J01271A013 1.....133-3701-201	2001-7141-00.....142-0207-011	2052-3500-00.....142-1701-511	4852-3575-02.....145-0701-602
SF2951-6116.....142-1701-596	J01271A013 9.....133-3701-206	2001-7188-00.....142-0203-011	2052-3500-02.....142-1701-516	4852-3576-02.....145-0701-612
SF2951-6122.....142-1701-616	J01271A014 1.....133-3701-231	2001-7941-00.....142-0694-031	2052-3501-00.....142-1701-561	4858-3577-02.....145-0701-002
SF2951-6124.....142-1701-566	J01271A016 1.....133-3701-311	2001-7985-00.....142-0693-001	2052-3501-02.....142-1701-566	4880-2362-02.....145-0901-801
SF2951-6125.....142-1701-516	J01271A016 9.....133-3701-316	2002-5015-00.....142-0594-001	2052-3502-00.....142-1701-611	4881-2361-02.....145-0901-811
SF2951-6146.....142-1701-516		2002-5016-00.....142-0593-001	2052-3502-02.....142-1701-616	4882-2361-02.....145-0901-821
SF2955-6166.....142-1801-546	TROMPETER.....EMERSON	2004-7188-00.....142-0103-401	2052-5674-00.....142-1701-201	5031-7188-09.....131-6403-001
SF2955-6177.....142-1801-606	UPL220-009.....CPMC-68-18	2004-7941-00.....142-0594-401	2052-5674-02.....142-1701-206	5034-7188-09.....131-6303-401
SF2955-6178.....142-1801-536	UPL220-017.....CPMC-68-5	2004-7985-00.....142-0593-401	2054-0000-00.....142-0701-701	5037-7188-09.....131-6403-101
SF2955-6197.....142-1801-626	UPL220-023.....CPMC-68-10	2007-5054-02.....142-0694-101	2054-0000-02.....142-0701-706	5056-0000-09.....131-6701-401
SF2955-6197.....142-1801-636	UPL220-026.....CPMC-68-33	2007-5055-02.....142-0693-101	2054-1201-00.....142-1711-001	5058-0000-09.....131-6701-411
SF2955-6297.....142-1801-536	UPL2000-D1.....CPMC-68-34	2007-7141-00.....142-0207-101	2054-1201-02.....142-1711-006	5062-0000-09.....131-6701-201
SF2955-6298.....142-1801-606	UPL2000-D2.....CPMC-68-35	2007-7188-00.....142-0203-101	2054-1231-00.....142-1711-001	5064-0000-09.....131-6701-301
SF2955-6299.....142-1801-626	UPL2000-D3.....CPMC-68-2	2013-5005-00.....142-0408-011	2054-1231-02.....142-1711-006	5131-7188-09.....131-1403-001
SF2955-6299.....142-1801-636	UPL2000-D4.....CPMC-68-45	2031-5005-02.....142-0408-016	2054-1241-00.....142-1711-011	5131-7188-09.....131-3403-001
SF2955-6300.....142-1801-646	UPL2000-D6.....CPMC-68-36	2031-5006-00.....142-0403-011	2054-1241-02.....142-1711-016	5131-7196-09.....131-3402-001
SF2955-6305.....142-1801-616	UPL2000-D7.....CPMC-68-20	2031-5006-02.....142-0403-016	2054-1251-00.....142-1711-031	5132-7188-09.....131-3303-001
SF2955-6333.....142-1801-616	UPL2000-D8.....CPMC-68-50	2031-5012-00.....142-0403-001	2054-1251-02.....142-1711-036	5132-7196-09.....131-3302-001
SF2960-6001.....142-0701-706	UPL2000-D10.....CPMC-68-3	2031-5055-00.....142-0407-011	2054-1261-00.....142-1711-021	5137-7188-09.....131-1403-101
SF2960-6025.....142-1711-006		2031-5055-02.....142-0407-016	2054-1261-02.....142-1711-026	5137-7188-09.....131-3403-101
SF2960-6268.....142-1711-026	TYCO/AMP.....EMERSON	2034-5005-00.....142-0303-401	2056-0000-00.....142-0701-401	5137-7196-09.....131-1402-101
SF2960-6274.....142-1711-036	1-221128-0.....CPMC-88-1	2034-5031-00.....142-0302-401	2056-5006-00.....142-0701-411	5137-7196-09.....131-3402-101
SF2960-6613.....142-1711-536	1-221128-1.....CPMC-88-2	2037-5008-00.....142-0403-101	2060-0000-00.....142-0701-531	5152-0000-09.....131-3701-631
SF2960-6701.....142-1711-526	1-221128-2.....CPMC-88-3	2037-5056-00.....142-0407-101	2060-0000-02.....142-0701-536	5156-0000-09.....131-3701-401
SF2960-6703.....142-1711-516	1-221128-6.....CPMC-88-2	2037-5100-00.....142-0402-101	2064-0000-00.....142-0701-301	5158-0000-09.....131-3701-411
211-03SF.....142-1801-536	1-221128-7.....CPMC-88-2	2051-1350-00.....142-1801-601	2080-0000-00.....142-0901-801	5162-0000-09.....131-1701-201
211-12SF.....142-1801-556	1-226208-3.....CPL-259-18	2051-3354-00.....142-1801-601	2081-0000-00.....142-0901-811	5162-0000-09.....131-3701-201
211-14SF.....142-1801-566	1-227079-0.....CPMC-88-13	2051-3354-02.....142-1801-606	2082-5133-00.....142-0901-821	5164-0000-09.....131-1701-371
211-16SF.....142-1801-576	1-227079-1.....CPMC-88-2	2051-3356-00.....142-1801-621	2084-0000-00.....142-0901-401	5164-0000-09.....131-3701-301
212-01SF.....142-1701-516	1-227079-3.....CPMC-88-2	2051-3356-02.....142-1801-626	221117-1.....142-0408-016	5801-7985-63.....133-3693-001
212-03SF.....142-1701-536	1-227079-4.....CPM-88-19	2051-3358-00.....142-1801-541	221117-2.....142-0403-016	5818-5002-10.....142-0003-236
212-06SF.....142-1701-526	1-227079-5.....CPM-88-19	2051-3358-02.....142-1801-546	221117-3.....142-0404-016	5818-5003-10.....142-0003-246
212-08SF.....142-1701-566	1-227079-6.....CPM-88-19	2051-3359-00.....142-1801-641	221119-1.....142-0308-016	5818-5005-10.....142-0002-226
212-10SF.....142-1701-586	1-227079-7.....CPMC-88-18	2051-3359-02.....142-1801-646	221119-2.....142-0303-016	5831-5002-10.....133-3402-006
212-12SF.....142-1701-576	1-227079-9.....CPMC-88-18	2051-3362-00.....142-1801-531	221119-3.....142-0304-016	5831-5003-10.....133-3403-006
212-13SF.....142-1701-556	1-227086-0.....CPN-1	2051-3362-02.....142-1801-536	221128-1.....CPMC-88-1	5837-5002-10.....133-3402-106
212-26SF.....142-1701-506	1-228509-2.....CP-625U	2051-3363-00.....142-1801-631	221128-2.....CPMC-88-2	5837-5003-10.....133-3403-106
213-01SF.....142-1801-616	1-330022-2.....CP-BNC-CAP-1	2051-3363-02.....142-1801-636	221128-3.....CPMC-88-3	5837-5010-63.....133-3403-101
213-03SF.....142-1801-636	134866-1.....CPMC-TNC-2	2052-0000-00.....142-0701-631	221128-4.....CPMC-88-1	5862-5002-10.....133-3701-216
213-06SF.....142-1801-626	1-413592-4.....CP-AD505	2052-1215-00.....142-1701-191	221128-5.....CPMC-88-2	5862-5003-10.....133-3701-206
213-08SF.....142-1801-606	1-414586-4.....CPMC-88-3	2052-1215-02.....142-1701-196	221128-6.....CPMC-88-3	5862-5004-10.....133-3701-226
214-01SF.....142-1701-616	1060031-1.....145-0701-602	2052-1350-00.....142-1701-621	221169-1.....142-0308-416	5863-0000-10.....133-3801-201
214-03SF.....142-1701-636	1060035-1.....145-0701-002	2052-3350-00.....142-1701-501	221169-2.....142-0303-416	5864-5001-10.....133-3701-306
214-06SF.....142-1701-626	1060041-1.....145-0901-801	2052-3350-02.....142-1701-506	221169-3.....142-0304-416	5864-5002-10.....133-3701-326
214-08SF.....142-1701-606	1060041-1.....145-0901-811	2052-3352-02.....142-1701-521	221185-2.....CPMC-78-2	5864-5003-10.....133-3701-316
	1063404-11.....142-1000-033	2052-3352-02.....142-1701-526	221244-1.....CP-BNC-BM-001	8598-0294-00.....142-1000-033
	2-221128-5.....CPMC-88-14	2052-3354-00.....142-1701-601	221325-1.....CP-AD355	X65 X08 G022 X99.....142-0003-201
TELEGARTNER.....EMERSON	2-221128-7.....CPMC-88-2	2052-3354-02.....142-1701-606	221543-2.....CP-AD505	X65 X08 J022 X99.....142-0003-206
H01000A005 7.....142-0003-236	2-225395-0.....CPMC-88-2	2052-3356-00.....142-1701-621	221551-3.....CP-AD555	X65 X11 G022 X99.....142-0003-301
J01270A000 1.....133-3402-001	2-225395-9.....CPMC-88-3	2052-3356-02.....142-1701-626	2831-7316-02.....142-0404-016	X65 X11 J022 X99.....142-0003-306
J01270A000 9.....133-3402-006				

Competitor Cross Reference

Ultra Miniature Connectors UMC to U.FL Cross Reference

Emerson	Hirose
128-0711-201	U.FL-R-SMT(10)
415-0084-050	U.FL-2LP(V)-04N1-A-50
415-0084-100	U.FL-2LP(V)-04N1-A-100
415-0084-150	U.FL-2LP(V)-04N1-A-150
415-0084-200	U.FL-2LP(V)-04N1-A-200
415-0084-250	U.FL-2LP(V)-04N1-A-250
415-0084-300	U.FL-2LP(V)-04N1-A-300
415-0084-500	U.FL-2LP(V)-04N1-A-500
415-0085-050	U.FL-2LP-04N2-A-50
415-0085-100	U.FL-2LP-04N2-A-100
415-0085-150	U.FL-2LP-04N2-A-150
415-0085-200	U.FL-2LP-04N2-A-200
415-0085-250	U.FL-2LP-04N2-A-250
415-0085-300	U.FL-2LP-04N2-A-300
415-0085-300	U.FL-2LP-04N2-A-500
415-0086-050	U.FL-2LP-068N2-A-50
415-0086-100	U.FL-2LP-068N2-A-100
415-0086-150	U.FL-2LP-068N2-A-150
415-0086-200	U.FL-2LP-068N2-A-200
415-0086-250	U.FL-2LP-068N2-A-250
415-0086-300	U.FL-2LP-068N2-A-300
415-0086-500	U.FL-2LP-068N2-A-500
415-0087-050	U.FL-2LP-066J2-A-50

Emerson	Hirose
415-0087-100	U.FL-2LP-066J2-A-100
415-0087-150	U.FL-2LP-066J2-A-150
415-0087-200	U.FL-2LP-066J2-A-200
415-0087-250	U.FL-2LP-066J2-A-250
415-0087-300	U.FL-2LP-066J2-A-300
415-0087-500	U.FL-2LP-066J2-A-500
415-0088-050	U.FL-2LP-088K2T-A-50
415-0088-100	U.FL-2LP-088K2T-A-100
415-0088-150	U.FL-2LP-088K2T-A-150
415-0088-200	U.FL-2LP-088K2T-A-200
415-0088-250	U.FL-2LP-088K2T-A-250
415-0088-300	U.FL-2LP-088K2T-A-300
415-0088-500	U.FL-2LP-088K2T-A-500
415-0104-150	U.FL-LP(V)-04N1-A-150
415-0104-250	U.FL-LP(V)-04N1-A-250
415-0105-150	U.FL-LP-04N2-A-150
415-0105-250	U.FL-LP-04N2-A-250
415-0106-150	U.FL-LP-068N2-A-150
415-0106-250	U.FL-LP-068N2-A-250
415-0107-150	U.FL-LP-066J2-A-150
415-0107-250	U.FL-LP-066J2-A-250
415-0108-150	U.FL-LP-088K2T-A-150
415-0108-250	U.FL-LP-088K2T-A-25

UMC Compatibility Table Emerson vs. HIROSE

UMC Family	Mated Height (mm)	AWG (O.D. mm)	Emerson		HIROSE	
			Plating (Contact/Ground)	Part No.	Plating (Contact/Ground)	Part No.
UMC Receptacle	2.5	N/A	Gold	128-0711-201	Gold/Silver	U.FL-R-SMT (10)
UMC MP Plug	2.5	30 (1.37)	Gold	415-0088-xxx	Gold/Silver	U.FL-LP-088
UMC MP Plug	2.5	32 (1.32)	Gold	415-0087-xxx	Gold/Silver	U.FL-LP-066
		32 (1.13)	Gold	415-0086-xxx	Gold/Silver	U.FL-LP-066
		36 (0.81)	Gold	415-0085-xxx	Gold/Silver	U.FL-LP-040
UMC LP Plug	2.0	36 (0.81)	Gold	415-0084-xxx	Gold/Silver	U.FL-LP(V)-040
UMC ULP Plug	1.55	N/A	Gold	415-0109-xxx	Gold/Silver	CL-331-0482-6-10

Non-Magnetic RF Competitor Cross Reference

Emerson Part No.	Competitor Part No.	Competitor
135-9403-001	908-NM41300	Amphenol
135-9402-001	908-NM41200	Amphenol
135-9403-101	908-NM43300	Amphenol
135-9402-111	908-NM43200	Amphenol
135-9701-201	908-NM22106	Amphenol
135-9701-301	908-NM24100	Amphenol
133-9403-001	919-NM101P-51S	Amphenol
133-9403-101	919-NM104P-51A	Amphenol
133-9402-101	919-NM109J-51P	Amphenol
133-9701-201	919-NM109J-51P	Amphenol
131-9403-021	903NM285P-51S	Amphenol
131-9403-101	903-NM289P-51A	Amphenol
131-9701-201	903-NM415J-51P	Amphenol
135-9402-111	R110 170 117	Radiall
135-9701-201	R110 426 097	Radiall
142-9407-001	R125 075 097	Radiall
142-9403-101	R125 172 167	Radiall
142-9701-201	R125 426 067	Radiall
131-9403-021	R114 082 097	Radiall
131-9403-101	R114 186 097	Radiall

Competitor Cross Reference

Type N Competitor Cross Reference

Emerson	Radiall	M/A-Com	Amphenol	Tyco/Amp	Telegartner	Rosenberger	Huber-Suhner
138-4303-407	R161311300	3004-7388-10	82-6156			53K507-802N3	
138-4304-407	R161311300					53K507-803N3	
138-4307-407	R161329000	3004-7341-10	82-5378	1-225667-2	J01021A0147	53K507-106N3	24N-50-3-11C
138-4308-407	R161329200	3004-7341-10	82-5373	225363-2	J01021A0148	53K507-108N3	24N-50-3-12C
138-4316-407	R161331000	N15H61H001X99	82-346-RFX	225094-2	J01021A0060	53K501-115N3	24N-50-7-14C
138-4318-407	R161331200	N15H61H004X99		225667-1	J01021A0092	53K501-117N3	24N-50-7-15C
138-4349-407	R161331060		82-6143-1000				
138-4403-007	R161072000	3031-7338-10			J01020A0103	53S107-802N3	
138-4403-107	R161181000		82-6048-1000		J01020A0040		
138-4404-007	R161072000				J01020A0104	53S107-803N3	
138-4404-107	R161181300				J01020A0039		
138-4407-007	R161082000	3031-7358-10	82-5375	1-225661-2	J01010A0108	53S107-106N3	11N-50-3-28C
138-4407-107	R161182000			1-225669-2	J01020A0035	53S205-315N3	16N-50-3-26C
138-4408-007	R161083000	3031-7341-10	82-5370	225699-1	J01020A0113	53S107-108N3	11N-50-3-29C
138-4408-107	R161183000		82-4442	225365-2	J01020A0036	53S205-317N3	16N-50-3-27C
138-4416-007	R161075000	N15A61H001X99	82-340	225661-2	J01020A0107	53S101-115N3	11N-50-7-43C
138-4416-107	R161184000	N15B61H001X99	82-336	225669-2	J01020A0046		16N-50-7-30C
138-4418-007	R161088000	N15A61H004X99	82-332	225661-1	J01020A0110	53S101-115N3	11N-50-7-44C
138-4418-107	R161186000	N15B61H004X99	82-4440-1001	225669-1	J01020A0045		16N-50-7-31C
138-4449-007	R161075060		82-340-1052		J01020A0127	53S101-1N9N3	
138-4593-401	R161335200	3004-7985-00	82-6093-RFX	228658-2	J01021H0087	52K504-271N3	24N-50-2-14
138-4594-401	R161336000	3004-7941-00	82-6097-RFX	228658-1	J01021A0151	53K504-272N3	24N-50-3-14
138-4596-401	R161337200		82-6162		J01021A0109	53K504-273N3	24N-50-5-39C
138-4693-001	R161050300	3001-7985-00		1057094-1			11N-50-2-14
138-4693-011	R161050300	3001-7985-00					11N-50-2-14
138-4694-001	R161051000	3001-7941-00	82-5955-RFX	1057088-1	J01020A0109	53S101-272B1	11N-50-3-13
138-4694-011	R161051000	3001-7941-00	82-5955-RFX		J01020A0109	53S101-272B1	11N-50-3-13
138-4696-001	R161054000		82-6124		J01020A0112	53S101-273B1	11N-50-5-39C
138-4696-011	R161054000		82-6124		J01020A0112	53S101-273B1	11N-50-5-39C
138-4701-407	R161586137	N15M35999X99			J01021A1084	53K505-200N3	
138-4701-607	R161404000	3052-0000-10	82-97	1-1337418-0	J01021A1082	53K401-200N3	23N-50-0-23
138-4901-407	R161730000	N15R07999X99	82-66		J01024A1088	53K501-K00N3	34N-50-0-51
138-4901-807	R161705000	3680-0000-02	82-101	227945-2	J01024A1092	53K101-K00N3	31N-50-0-51
138-4901-817	R161703000	3681-0000-02	82-100	1058661-1	J01024A1094	53K101-S00N3	32N-50-0-51

SMA Stainless Steel Competitor Cross Reference

Emerson	Huber-Suhner	Amp/Tyco	Radiall	Amphenol	AEP
141-0403-012	11SMA-50-2-55C	225532-4	R125072001	901-9511-3SFC	9101-9573-03
141-0404-012	11SMA-50-2-56C		R125072081	901-9511-12SFC	9101-9573-19
141-0407-012	11SMA-50-3-55C	225532-1	R125075001	901-9511-2SF	9101-9573-06
141-0408-012	11SMA-50-3-56C	225532-3	R125076001	901-9511-1SF	9101-9573-01
141-0403-102	16SMA-50-2-55C	225609-4	R125172001	901-9531-3SF	9043-9523-03
141-0404-102	16SMA-50-2-56C		R125174011	901-9531-12SF	9043-9523-19
141-0407-102	16SMA-50-3-55C	225609-1	R125175001	901-9531-2SF	9043-9523-06
141-0408-102	16SMA-50-3-56C	225609-3	R125176001	901-9531-1	9043-9523-01
141-0693-002	11SMA-50-2-65		R125052002	901-9201-2A	9401-1083-010
141-0694-002	11SMA-50-3-65				9401-1083-109
141-0694-012	11SMA-50-3-64		R125054002	901-9201-1A	9301-1063-009
141-0693-062	11SMA-50-2-65		R125052002	901-9723	9401-1583-010
141-0694-062	11SMA-50-3-65		R125057002	901-9808	9401-1583-109
141-0303-412		225608-4	R125312121	901-9610-3SF	9130-9573-03
141-0304-412		1-225608-1	R125313121	901-9610-12SF	9130-9573-19
141-0307-412			R125314121	901-9610-2SF	9130-9573-06
141-0308-412		225608-3	R125315121	901-9610-1SF	9130-9573-01
141-0593-001			R125222000	901-9202-2A	9402-1533-010
141-0594-001			R125225000	901-9202-1A	9402-1583-009
141-0593-401	24SMA-50-2-41		R125326000		9453-1083-010
141-0594-401	24SMA-50-3-41		R125325000		9453-1083-009
141-0593-421	24SMA-50-2-41		R125326000		9453-1583-010
141-0594-421	24SMA-50-3-41		R125325000		9453-1083-009
141-0701-201	82SMA-50-0-1	221789-1	R125426000	901-144	9650-1113-000
141-0701-301	85SMA-50-0-1	221790-1	R125680000	901-143	9647-1513-000
141-0701-402	22SMA-50-0-54	228496-1	R125553001	901-9211-SF	9412-9113-000
141-0701-602	23SMA-50-0-61	221641-1	R125454001		9408-9113-000
141-0701-612	23SMA-50-0-51	221640-1	R125403001	901-9215-SF	9404-9113-000
141-0701-622	23SMA-50-0-63		R125464274	901-9000-CCSF	9008-9113-000
141-0701-602	23SMA-50-0-53		R125415275	901-9204-CCSF	9004-9113-0001



Cinch Connectivity Solutions North America Office

T +1 507.833.8822
ccsorders@us.cinch.com

Cinch Connectivity Solutions Ltd European Office

T +44 (0) 1245 342060
CinchConnectivity@eu.cinch.com

Cinch Connectivity Solutions Asia Pacific Office

T +86 21 5442 7668
ccs.asia.sales@as.cinch.com

Innovative Interconnect Solutions Across the Globe

In operation since 1917, Cinch supplies high quality, high performance connectors and cables globally to the Aerospace, Military/Defense, Commercial Transportation, Oil & Gas, High End Computer, and other markets. We provide custom solutions with our creative, hands on engineering and end to end approach.

Our diverse product offerings include: connectors, enclosures and cable assemblies utilizing multiple contact technologies including copper and fiber optics. Our product engineering and development activities employ cutting edge technologies for design and modeling, and our various technologies and expertise enable us to deliver custom solutions and products for our strategic partnerships. We also serve a broad range of commercial markets, largely through our highly efficient distribution network.

We aim to exceed our customer's expectations, and to continually provide innovative solutions to the rapidly changing needs of the markets, and customers, we serve. For more information, visit cinch.com

