

# General-purpose Relay MY

## An Improved Miniature Power Relay with Many Models for Sequence Control and Power Applications

- A wide range of relay variations including ones with operation indicators, built-in diodes, etc.
- Arc barrier standard on 3- and 4-pole Relays.
- Dielectric strength: 2,000 VAC.



## Ordering Information

### List of Models

Type	Contact form	Plug-in socket/solder terminals		PCB terminals	Upper-mounting/ solder terminals
			With indicator		
<b>Standard</b>	DPDT	MY2	MY2N	MY2-02	MY2F
	DPDT (bifurcated)	MY2Z	MY2ZN	MY2Z-02	MY2ZF
	3PDT	MY3	MY3N	MY3-02	MY3F
	4PDT	MY4	MY4N	MY4-02	MY4F
	4PDT (bifurcated)	MY4Z	MY4ZN	MY4Z-02	MY4ZF
<b>With built-in diode (DC only)</b>	DPDT	MY2-D	MY2N-D2	—	—
	DPDT (bifurcated)	MY2Z-D	MY2ZN-D2	—	—
	3PDT	MY3-D	MY3N-D2	—	—
	4PDT	MY4-D	MY4N-D2	—	—
	4PDT (bifurcated)	MY4Z-D	MY4ZN-D2	—	—
<b>With built-in CR (AC only)</b>	DPDT	MY2-CR	MY2N-CR	—	Not available.
	DPDT (bifurcated)	MY2Z-CR	—	—	
	3PDT	MY3-CR	—	—	
	4PDT	MY4-CR	MY4N-CR	—	
	4PDT (bifurcated)	MY4Z-CR	—	—	
<b>With test button</b>	DPDT	MY2I4	MY2I4N	—	—
	4PDT	MY4I4	MY4I4N	—	—

**Note:** 1. When ordering, add the rated coil voltage to the model number. Rated coil voltages are given in the coil ratings table.

Example: MY2, 6 VAC

Rated coil voltage

2. The standard contacts for MY2Z-series Relays and for the MY4Z are gold-plated.

## ■ Accessories (Order Separately)

### Sockets

Poles	Front-mounting socket (DIN-rail/screw mounting)	Back-mounting socket				
		Solder terminals		Wire-wrap terminals		PCB terminals
		W/ clip	W/o clip	W/ clip	W/o clip	
2	PYF08A PYF08A-E (finger protection) PYF08A-N (finger protection)	PY08	PY08-Y1	PY08QN	PY08QN-Y1	PY08-02
3	PYF11A	PY11	PY11-Y1	PY11QN	PY11QN-Y1	PY11-02
4	PYF14A PYF14A-N (finger protection) PYF14A-E (finger protection)	PY14 PY14-3*	PY14-Y1	PY14QN	PY14QN-Y1	PY14-02

**Note:** \*1. Equipped with operation check terminal.

2. The PYF08A(-E), PYF11A, and PYF14A(-E) have been approved as individual sockets by UL S08 and CSA C22.2.

### Mounting Plates for Sockets

Socket model	For 1 socket	For 18 sockets	For 36 sockets
PY08, PY11, PY14, PY08QN(2), PY11QN(2), PY14QN(2)	PYP-1	PYP-18	PYP-36

**Note:** PYP-18 and PYP-36 can be cut into any desired length in accordance with the number of sockets.

### Socket Hold-down Clip Pairing

Relay type	Poles	Front-connecting sockets (rail-/screw-mounted)		Back-connecting sockets			
		Socket	Clip	Solder/wire-wrap terminals		PCB terminals	
				Socket	Clip	Socket	Clip
Standard, bifurcated contacts, operation indicator, built-in diode.	2	PYF08A-N, PYF08A-E, PYF08A	PYC-A1	PY08(QN)	PYC-P	PY08(QN)	PYC-P
	3	PYF11A		PY11(QN)		PY11(QN)	
	4	PYF14A-N, PYF14A-E, PYF14A		PY14(QN)		PY14(QN)	
Test button	2	PYF08A-N, PYF08A-E, PYF08A	PYC-A1	PY08(QN)	PYC-P2	PY08(QN)	PYC-P2
	3	PYF11A		PY11(QN)		PY11(QN)	
	4	PYF14A-N, PYF14A-E, PYF14A		PY14(QN)		PY14(QN)	
CR circuit	2	PYF08A-N, PYF08A-E, PYF08A	Y92H-3	PY08(QN)	PYC-1	PY08(QN)	PYC-1
	3	PYF11A		PY11(QN)		PY11(QN)	
	4	PYF14A-N, PYF14A-E, PYF14A		PY14(QN)		PY14(QN)	

# Specifications

## ■ Coil Ratings

	Rated voltage	Rated current		Coil resistance	Inductance (reference value)		Must operate	Must release	Max. voltage	Power consum. (Approx.)
		50 Hz	60 Hz		Arm. OFF	Arm. ON				
AC	6 V	214.1 mA	183 mA	12.2 Ω	0.04 H	0.08 H	80% max.	30% min.	110%	1.0 to 1.2 VA (60 Hz)
	12 V	106.5 mA	91 mA	46 Ω	0.17 H	0.33 H				
	24 V	53.8 mA	46 mA	180 Ω	0.69 H	1.30 H				
	50 V	25.7 mA	22 mA	788 Ω	3.22 H	5.66 H				
	100/110 V	11.7/12.9 mA	10/11 mA	3,750 Ω	14.54 H	24.6 H				
	110/120 V	9.9/10.8 mA	8.4/9.2 mA	4,430 Ω	19.20 H	32.1 H				
	200/220 V	6.2/6.8 mA	5.3/5.8 mA	12,950 Ω	54.75 H	94.07 H				
220/240 V	4.8/5.3 mA	4.2/4.6 mA	18,790 Ω	83.50 H	136.40 H	0.9 to 1.1 VA (60 Hz)				
DC	6 V	150 mA		40 Ω	0.17 H	0.33 H	10% min.		0.9 W	
	12 V	75 mA		160 Ω	0.73 H	1.37 H				
	24 V	36.9 mA		650 Ω	3.20 H	5.72 H				
	48 V	18.5 mA		2,600 Ω	10.60 H	21.00 H				
	100/110 V	9.1/10 mA		11,000 Ω	45.60 H	86.20 H				

- Note:**
1. The rated current and coil resistance are measured at a coil temperature of 23°C with tolerances of +15%/–20% for rated currents and ±15% for DC coil resistance.
  2. Performance characteristic data are measured at a coil temperatures of 23°C.
  3. AC coil resistance and impedance are provided as reference values (at 60 Hz).
  4. Power consumption drop was measured for the above data. When driving transistors, check leakage current and connect a bleeder resistor if required.

## ■ Contact Ratings

Item	Double- or three-pole		Four-pole	
	Resistive load (cosφ = 1)	Inductive load (cosφ=0.4, L/R=7 ms)	Resistive load (cosφ = 1)	Inductive load (cosφ=0.4, L/R=7 ms)
<b>Rated load</b>	5 A, 220 VAC 5 A, 24 VDC	2 A, 220 VAC 2 A, 24 VDC	3 A, 220 VAC 3 A, 24 VDC	0.8 A, 220 V 1.5 A, 24 VDC
<b>Carry current</b>	5 A		3 A	
<b>Max. switching voltage</b>	250 VAC 125 VDC		250 VAC 125 VDC	
<b>Max. switching current</b>	5 A	5 A	3 A	3 A
<b>Max. switching capacity</b>	1,100 VA 120 W	440 VA 48 W	660 VA 72 W	176 VA 36 W
<b>Min. permissible load*</b>	Standard type: 100 mA, 5 VDC Bifurcated type: 100 μA, 1 VDC		Standard type: 1 mA, 1 VDC Bifurcated type: 100 μA, 1 VDC	

\*Note: P level:  $\lambda_{60} = 0.1 \times 10^{-6}$  /operation, reference value

## ■ Characteristics

Item	All relays
Contact resistance	50 mΩ max.
Operate time	20 ms max.
Release time	20 ms max.
Max. operating frequency	Mechanical: 18,000 operations/hr Electrical: 1,800 operations/hr (under rated load)
Insulation resistance	1,000 MΩ min. (at 500 VDC)
Dielectric strength	2,000 VAC, 50/60 Hz for 1 min (1,000 VAC between contacts of same polarity)
Vibration resistance	Destruction: 10 to 55 Hz, 1.0-mm double amplitude Malfunction: 10 to 55 Hz, 1.0-mm double amplitude
Shock resistance	Destruction: 1,000 m/s <sup>2</sup> (approx. 100G) Malfunction: 200 m/s <sup>2</sup> (approx. 20G)
Life expectancy	See following table.
Ambient operating temperature*	Single- and double-pole standard, bifurcated-contact, test-button, relays: -55°C to 70°C (with no icing) All other relays: -55°C to 60°C (with no icing)
Ambient operating humidity	35% to 85%
Weight	Approx. 85 g

**Note:** The values given above are initial values.

### Life Expectancy Characteristics

Relays	Mechanical life (at 18,000 operations/hr)	Electrical life (at 1,800 operations/hr under rated load)
Normal, With test button (except relays with operation indicator), With CR	AC: 50,000,000 operations min. DC: 100,000,000 operations min.	1-,2-,3-pole: 500,000 operations min. 4-pole: 200,000 operations min.
With operation indicator or built-in diode	AC: 50,000,000 operations min. DC: 100,000,000 operations min.	1-,2-,3-pole: 500,000 operations min. 4-pole: 200,000 operations min.
With bifurcated contacts	2-pole: 50,000,000 operations min. 4-pole:	2-pole: 200,000 operations min. 4-pole: 100,000 operations min.

**Note:** See following tables for real load life expectancies.

## ■ Life Expectancies Under Real Loads

### MY2

Rated voltage	Load type	Conditions	Operating frequency	Electrical life
100 VAC	AC motor	50 W, 100 VAC single-phase with 2.8-A inrush current, 0.4-A carry current	ON for 2 s, OFF for 30 s	100,000 operations
		50 W, 100 VAC single-phase with 1.6-A inrush current, 1-A carry current	ON for 1 s, OFF for 30 s	300,000 operations
	AC solenoid	24 W with 1-A carry current	ON for 1.5 s, OFF for 1.5 s	4,000,000 operations

### MY4

Rated voltage	Load type	Conditions	Operating frequency	Electrical life
100 VAC	AC solenoid	50 VA with 2-A inrush current, 0.7A carry current	ON for 1 s, OFF for 3 s	25,000 operations
	DC magnetic switch	25 W with L/R = 40 ms, 0.2-A carry current		500,000 operations
	AC magnetic switch	35 VA with 1.5-A inrush current, 0.35-A carry current		
24 VDC	DC solenoid	40 W with L/R = 10 ms, 1.6-A carry current	ON for 0.5 s, OFF for 1.5 s	5,000,000 operations
		30 W with L/R = 10 ms with 0.34-A carry current	ON for 0.5 s, OFF for 1.5 s	6,000,000 operations

### ■ Approved by Standards

Some MY Relays are available in models meeting various safety standards. When ordering, you must specify the desired standards. Refer to *Ordering Information* for specific models. Note that the rating recognized by the various standards sometimes vary from the ratings of the individual relays.

#### UL 508 Recognitions (File No. 41515)

No. of poles	Coil ratings	Contact ratings
2	6 to 240 VAC 6 to 125 VDC	5 A, 120 VAC resistive load 5 A, 28 VDC resistive load 5 A, 240 VAC inductive load
3		5 A, 28 VDC resistive load 5 A, 240 VAC inductive load
4	6 to 240 VAC 6 to 125 VDC	3 A 28 VDC resistive load 3 A 120 VAC inductive load 1.5 A, 240 VAC inductive load 5 A, 240 VAC inductive load (between contacts of same polarity) 5 A, 28 VDC resistive load (between contacts of same polarity) 0.2 A, 120 VDC

#### LR (No. 563KOB-204524)

Model	No. of poles	Coil ratings	Contact ratings
MY□-LR	2	6 to 240 VAC 6 to 120 VDC	2 A, 30 VDC inductive load 2 A, 200 VAC inductive load
	4		1.5 A, 30 VDC inductive load 0.8 A, 200 VAC inductive load 1.5 A, 115 VAC inductive load

#### CSA 22.2 No. 0 and No.14 (File No. LR31928)

Model	No. of poles	Coil ratings	Contact ratings
MY□	2, 3	6 to 240 VAC 6 to 120 VDC	5 A, 28 VDC resistive load 5 A, 240 VAC inductive load
	4		3 A, 28VDC resistive load 3 A, 240 VAC inductive load 5 A, 240 VAC inductive load (between contacts of same polarity) 5 A, 28 VDC resistive load (between contacts of same polarity) 0.2 A, 120 VDC

## Engineering Data

### ■ Maximum Switching Capacity

#### MY2, MY3

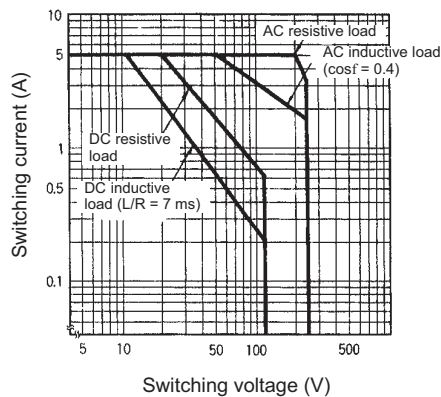

**MY4, MY4Z**

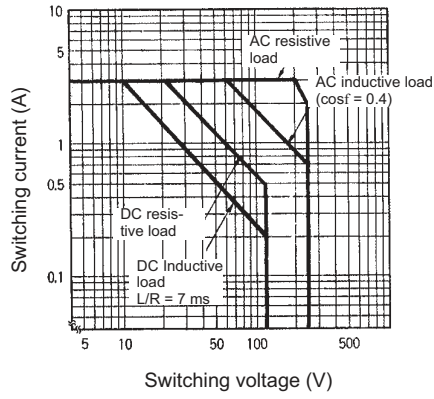

**Life Expectancy**

**MY2, MY3 (Resistive Loads)**

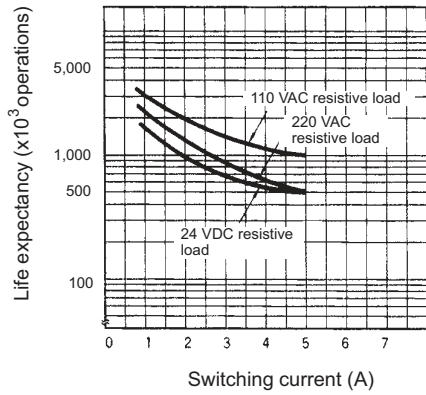

**MY2, MY3 (Inductive Loads)**

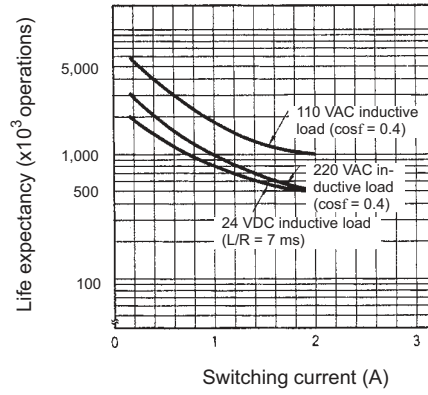

**MY4 (Resistive Loads)**

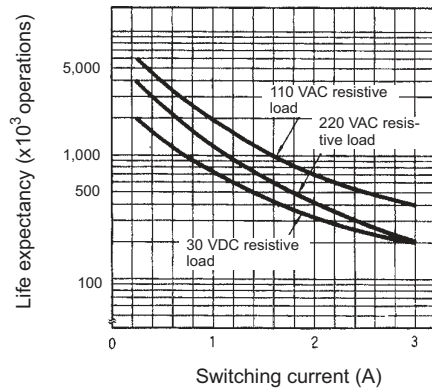

**MY4 (Inductive Loads)**

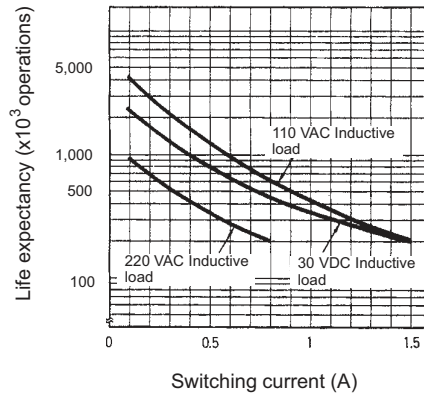

**MY4Z (Resistive Loads)**

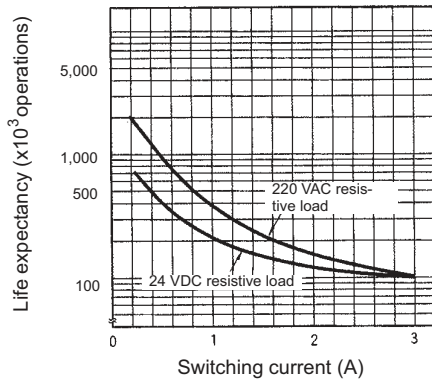

**MY4Z (Inductive Loads)**

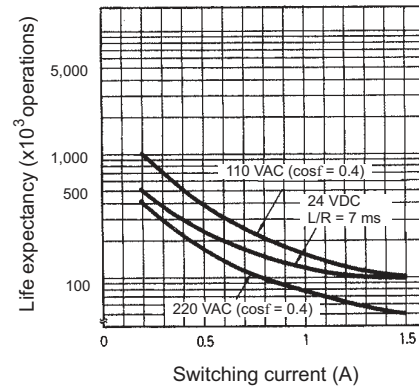

# Dimensions

Note: All units are in millimeters unless otherwise indicated.

## Relays with Solder Terminals

### MY2, MY2N, MY2N-D2

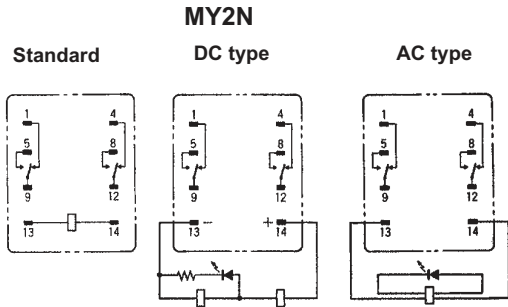
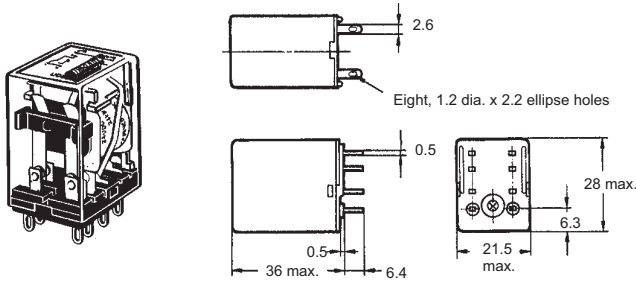

- Note:
1. AC type is equipped with a coil disconnection self-diagnostic function.
  2. Pay due attention as DC type has polarity.

### MY2N-D2

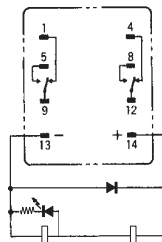

### MY3, MY3N, MY3N-D2,

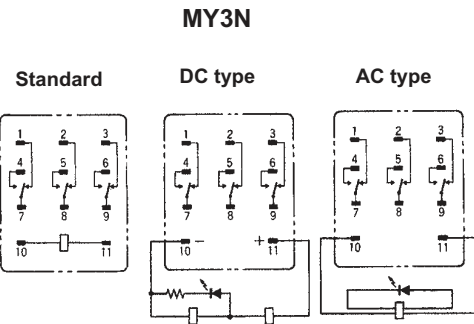
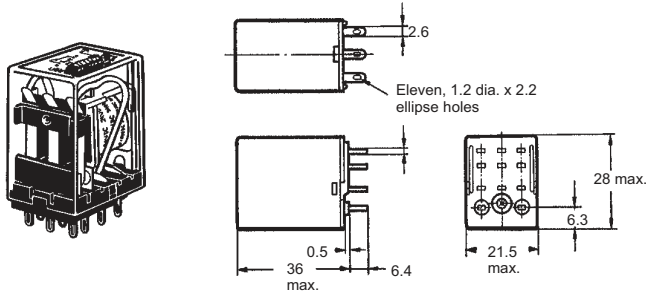

- Note:
1. AC type is equipped with a coil disconnection self-diagnostic function.
  2. Do not reverse the polarity of DC relays.

### MY3N-D2

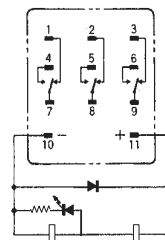

MY4

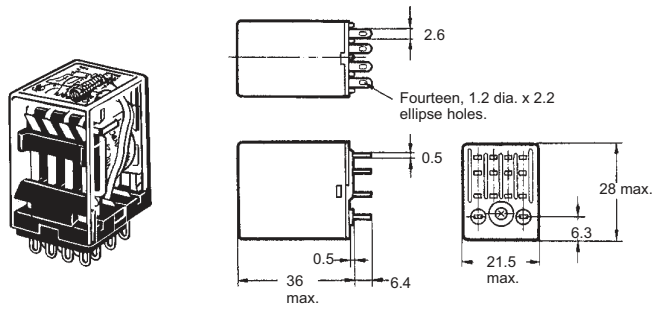

Terminal arrangement/internal connections  
(bottom view)

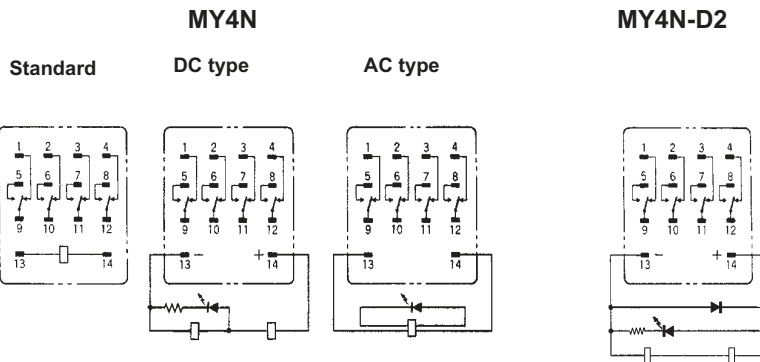

- Note:**
1. AC type is equipped with a coil disconnection self-diagnostic function.
  2. Do not reverse the polarity of DC relays.

MY□I4

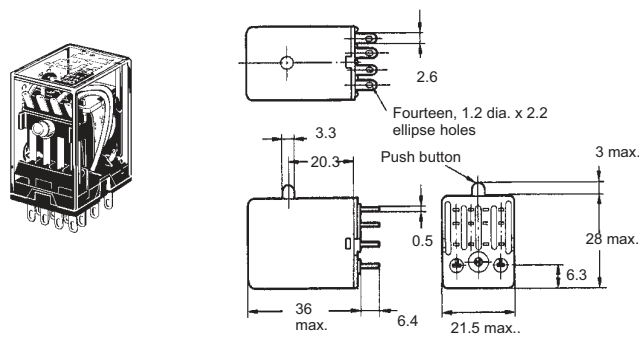

- Note:**
1. Mount the relay with a socket.
  2. Test button  
I4: AC with red push button  
DC with blue push button

**Note:** The terminal arrangement and internal connections of the above relays are as same as these of MY□ relays.



MY□(N)-CR, MY□(Z)-CR

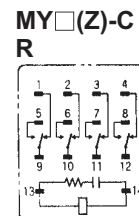
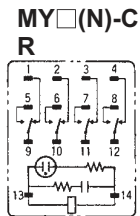
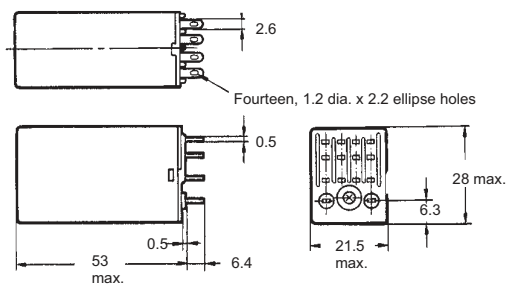

■ Relays with PCB Terminals

MY□-02

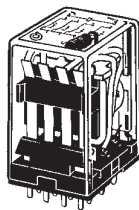

MY4-02 (4PDT)

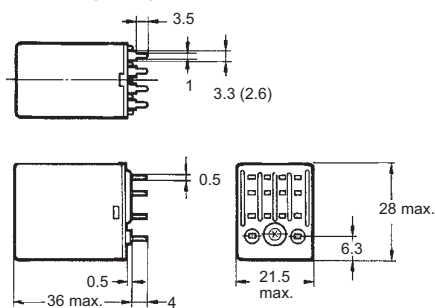

PC Board Mounting Holes

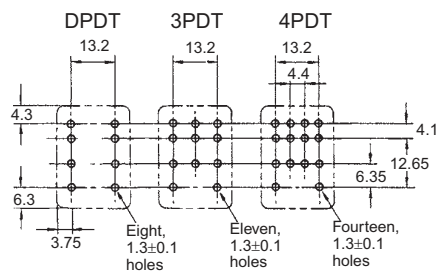

Note: The tolerance is ±0.1.

- Note:
1. The figures in the parentheses are for MY4-02.
  2. The above dimensions also apply to the DPDT and 3PDT Relays.
  3. The internal connections of the above Relays are as same as these of MY□ Relays.

## Upper-mounting Relays

MY□F



MY4F

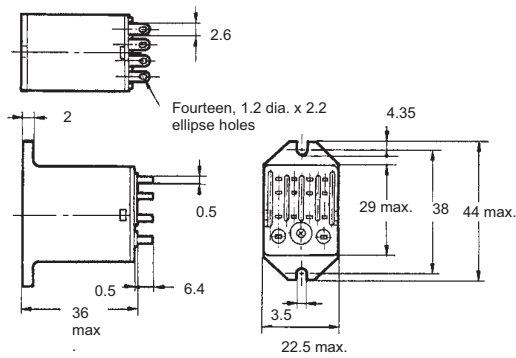

Mounting holes

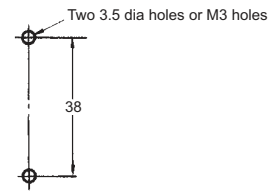

- Note:**
1. The above dimensions also apply to the DPDT, and 3PDT relays.
  2. The internal connections of the above relays are as same as these of MY□ relays.

## Mounting Height with Socket

DIN Track/Surface-mounting Socket

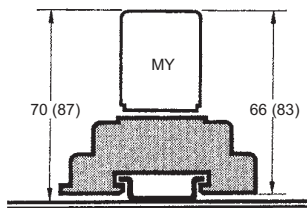

PYF□A(-E)

Back-mounting Socket

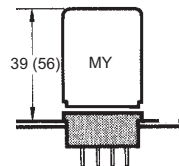

PY□

- Note:**
1. The PTF-A can be rail-mounted or screw-mounted.
  2. For the MY□-CR (CR circuit built-in type) model, figure in the parentheses apply.
  3. PYC-P hold down clip should be used with PYF08M.

**■ Sockets**

PYF08A-E

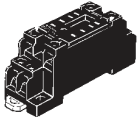

PYF08A-N

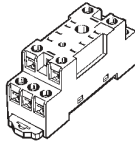

PYF08A

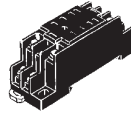

PY08



PY08-Y1

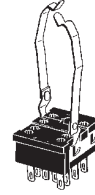

PY08QN

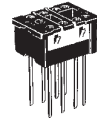

PY08-02



PYF14A-E

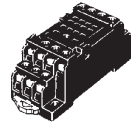

PYF14A-N

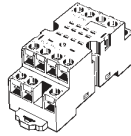

PY14

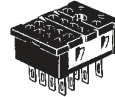

PY14-Y1

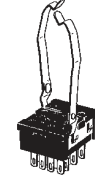

PY14QN(2)

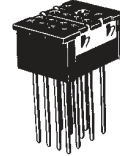

PY14QN(2)-Y1

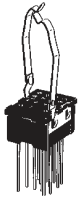

PY14-02

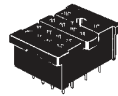

PYF11A

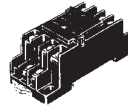

PY11



PY11QN(2)



PY11QN(2)-Y1



PY11-02



Mounting Plates for Sockets

PYP-1

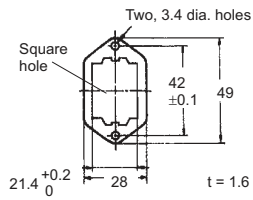

PYP-18

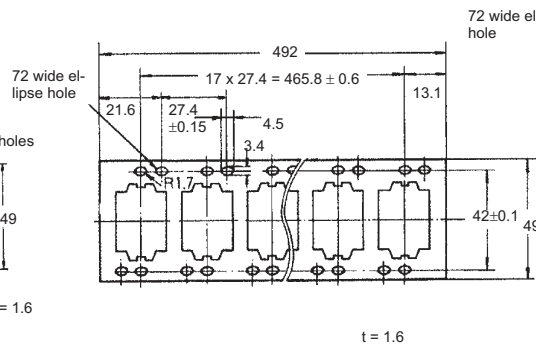

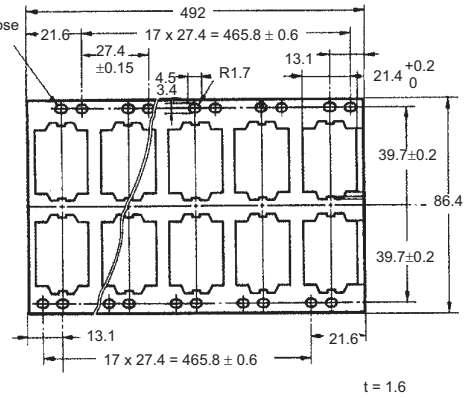

PYP-36

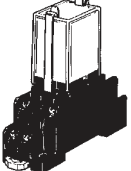
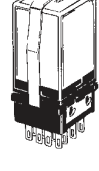
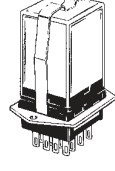
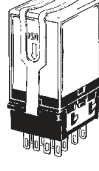
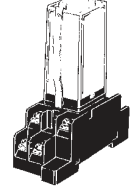

Hold-down Clips

Hold-down clips are used to hold relays to sockets and prevent them from coming loose due to vibration or shock.

Connection to socket		Connection to mounting plate		For relays with CR circuits	
<b>PYC-A1</b>	<b>PYC-P</b>	<b>PYC-S</b>	<b>PYC-P2</b>	<b>Y92H-3</b>	<b>PYC-1</b>
					

PY14-3 (for 4PDT) with operation check terminal

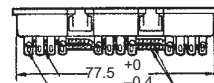
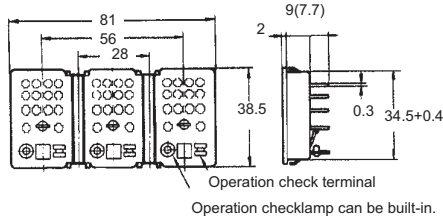
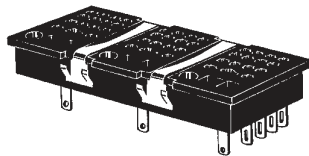

Three, 1.2 dia holes Two dia. holes Short-circuit lead wire

Mounting holes

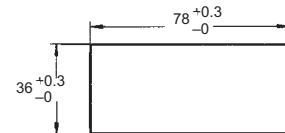

■ Safety Standards for Sockets

Item	Standards	File No.
PYF08A (-E), PYF11A	UL508	E87929
PYF14A (-E)	CSA22.2	LR31928

## Precautions

---

### ■ Connections

Do not reverse polarity when connecting DC-operated relays with built-in diodes or indicators DC-operated relays.

### ■ Mounting

- Whenever possible, mount relays so that it is not subject to vibration or shock in the same direction as that of contact movement.
- The test button should be pointed upwards when mounting (refer to the right figure).

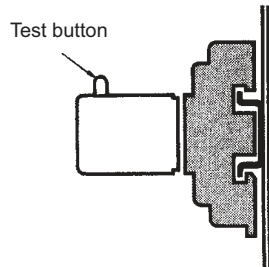



*Singapore Office:*  
**OMRON ELECTRONICS PTE. LTD.**  
438A Alexandra Road, #05-05/08  
(Lobby 2) Alexandra Technopark  
Singapore 119967  
Tel: (65) 6547 6789  
Fax: (65) 6547 6769  
E-mail: [mktg\\_sg@ap.omron.com](mailto:mktg_sg@ap.omron.com)



*Malaysia Office:*  
**OMRON ELECTRONICS SDN. BHD.**  
1101 Level 11 Uptown 1  
1 Jalan SS21/58 Damansara Uptown  
47400 Petaling Jaya, Selangor  
Malaysia  
Tel: (60-3) 7688 2888  
Fax: (60-3) 7688 2833  
E-mail: [my\\_enquiry@ap.omron.com](mailto:my_enquiry@ap.omron.com)



*Thailand Office:*  
**OMRON ELECTRONICS CO. LTD.**  
Rasa Tower 20th Floor  
555 Phaholyothin Road  
Chatuchak, Bangkok  
10900, Thailand  
Tel: (66-2) 937 0500  
Fax: (66-2) 937 0501  
CRM Call Centre: (66-2) 942 6700  
E-mail: [th\\_enquiry@ap.omron.com](mailto:th_enquiry@ap.omron.com)



*Indonesia Office:*  
**PT. OMRON ELECTRONICS**  
Graha Pratama Building, 3A Floor  
Jl. M.T. Haryono Kav 15  
Jakarta Selatan 12810  
Indonesia  
Tel: (62-21) 8370 9555  
Fax: (62-21) 8370 9550  
E-mail: [id\\_enquiry@ap.omron.com](mailto:id_enquiry@ap.omron.com)



*Philippines Office:*  
**OMRON ASIA PACIFIC PTE. LTD.  
MANILA REPRESENTATIVE OFFICE**  
2nd Floor, Kings Court II Building  
2129 Do Chino Roces Avenue  
Corner Dela Rosa Street  
1231 Makati City, Metro Manila  
Philippines  
Tel: (63-2) 811 2831  
Fax: (63-2) 811 2583  
E-mail: [ph\\_enquiry@ap.omron.com](mailto:ph_enquiry@ap.omron.com)



*Australia Offices:*  
Sydney Office:  
**OMRON ELECTRONICS PTY. LTD.**  
Omron House  
71 Epping Road, North Ryde  
Sydney, New South Wales 2113  
Australia  
Tel: (61-2) 9878 6377  
Fax: (61-2) 9878 6981  
Toll Free: 1800 678838  
E-mail: [au\\_enquiry@ap.omron.com](mailto:au_enquiry@ap.omron.com)

Melbourne Office:  
**OMRON ELECTRONICS PTY. LTD.**  
Axxess Corporate Park  
Unit 98, 45 Gilby Road  
Mt Waverley Victoria 3149  
Australia  
Tel: (61-3) 8588 2600  
Fax: (61-3) 8588 2690  
E-mail: [au\\_enquiry@ap.omron.com](mailto:au_enquiry@ap.omron.com)

Brisbane Office:  
**OMRON ELECTRONICS PTY. LTD.**  
Unit 14, 1378 Lytton Road  
Hemmant 4174, Queensland  
Australia  
Tel: (61-7) 3859 3900  
Fax: (61-7) 3348 8701  
E-mail: [au\\_enquiry@ap.omron.com](mailto:au_enquiry@ap.omron.com)

Adelaide Office:  
**OMRON ELECTRONICS PTY. LTD.**  
Suite 12, 18 Humpheries Terrace  
Kilkenny, SA 5009  
Australia  
Tel: (61-8) 8440 6412  
Fax: (61-8) 8345 1204  
E-mail: [au\\_enquiry@ap.omron.com](mailto:au_enquiry@ap.omron.com)



*New Zealand Office:*  
**OMRON ELECTRONICS LTD.**  
65 Boston Road, Mt Eden  
Private Bag 92620  
Symonds Street, Auckland  
New Zealand  
Tel: (64-9) 358 4400  
Fax: (64-9) 358 4411  
E-mail: [nz\\_enquiry@ap.omron.com](mailto:nz_enquiry@ap.omron.com)



*India Offices:*  
Bangalore Office:  
**OMRON AUTOMATION PVT. LTD.**  
No. 43, G.N. Complex  
St.Johns Road  
Bangalore - 560 042  
India  
Tel: (91-80) 4072 6400/401  
Fax: (91-80) 4146 6403  
E-mail: [in\\_enquiry@ap.omron.com](mailto:in_enquiry@ap.omron.com)

Noida Office:  
**OMRON AUTOMATION PVT. LTD.**  
212 & 213, 2nd Floor  
International Home Deco Park (IHDP)  
Plot No.7, Sector 127, Taj Express Way  
Noida 201301  
India  
Tel: (91-120) 4745 800  
Fax: (91-120) 4745 801  
E-mail: [newdelhi\\_enquiry@ap.omron.com](mailto:newdelhi_enquiry@ap.omron.com)

Mumbai Office:  
**OMRON AUTOMATION PVT. LTD.**  
102 & 103, Meadows, Sahar Plaza,  
Andheri-Kurla Road, Andheri East  
Mumbai - 400 059  
India  
Tel: (91-22) 4275 5600  
Fax: (91-22) 4275 5602  
E-mail: [mumbai\\_enquiry@ap.omron.com](mailto:mumbai_enquiry@ap.omron.com)



*Vietnam Offices:*  
**OMRON ASIA PACIFIC PTE. LTD.  
HANOI REPRESENTATIVE OFFICE**  
6th Floor, 92 Hoang Ngan Street  
Trung Hoa, Cau Giay  
Hanoi, SR Vietnam  
Tel: (84-4) 3556 3444  
Fax: (84-4) 3556 3443  
E-mail: [hn\\_enquiry@ap.omron.com](mailto:hn_enquiry@ap.omron.com)

**HO CHI MINH REPRESENTATIVE OFFICE**  
99 Nguyen Thi Minh Khai Street  
District 1, Ho Chi Minh City  
SR Vietnam  
Tel: (84-8) 3839 6666  
Fax: (84-8) 3830 1279  
E-mail: [hcm\\_enquiry@ap.omron.com](mailto:hcm_enquiry@ap.omron.com)

Asia Pacific Head Office:

## OMRON ASIA PACIFIC PTE. LTD.

438A Alexandra Road  
#05-05/08  
(Lobby 2) Alexandra Technopark  
Singapore 119967  
Tel: (65) 6835 3011 Fax: (65) 6835 2711  
E-mail: [ask@ap.omron.com](mailto:ask@ap.omron.com)

Website: [www.omron-ap.com](http://www.omron-ap.com)

Authorized Distributor