

Part Number : **W592**

Type	Size	Rating	Description
Incandescent	T10	24V 50mA	T-3¼ Miniature Edison Screw lamp

Dimensions(mm):

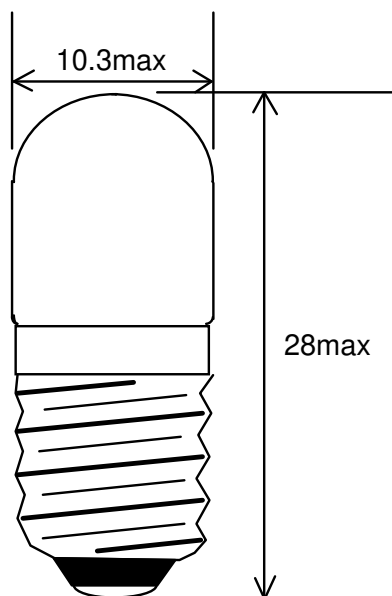

TEST VOLTS	CURRENT (mA)			LIGHT OUTPUT (Lm)			LIFE Hours
	Min.	Nom.	Max.	Min.	Nom.	Max.	
24	45	50	55	3	4	5	5000

## Notes:

- 1 Lamp base E10/13 in accordance with IEC61-1, (BS EN 60061-1) sheet 7004-22-x.
- 2 Lamp marking **CML 24V 50mA**
- 3 Filament shape C-2F
- 4 Bead colour white or clear
- 5 RoHS and REACH SVHC compliant

Issue # 1 : 1July13