



Curiosity PIC32MZ EF 2.0 Development Board Users Guide

Introduction

The Microchip Technology Curiosity PIC32MZ EF 2.0 Development Board (DM320209) includes an integrated programmer and debugger, which requires no additional hardware to get started. Users can expand functionality through MikroElektronika mikroBUS™ Click™ adapter boards, add Ethernet connectivity with the Microchip PHY Daughter Board, add Wi-Fi® connectivity capability using the Microchip expansion boards, and add audio input and output capability with Microchip audio daughter boards.

With or without expansion boards, the Curiosity PIC32MZ EF 2.0 Development Board provides the freedom to develop a variety of applications, including Bluetooth Audio, CAN, Graphics/UI, Internet of Things (IoT), robotics development, and proof-of-concept designs.

Curiosity PIC32MZ EF 2.0 Development Board Features

The Curiosity PIC32MZ EF 2.0 Development Board has the following features:

- PIC32MZ2048EFM144, 200 MHz, 2 MB Flash, 512 Kb SRAM
- On-Board debugger (PKoB4)
 - Real time Programming & Debugging
 - Virtual COM port (VCOM)
 - Data Gateway Interface (DGI)
- Two mikroBUS interfaces
- Two X32 Audio interfaces supporting Bluetooth® and Audio
- Ethernet interface
- Graphics interface
- Xplained pro extension compatible interface
- CAN interface
- User buttons
- User LEDs
- 8 MB QSPI memory
- Arduino Uno R3 compatible interface

Kit Contents

The kit contains one Curiosity PIC32MZ EF 2.0 Development Board (DM320209).

Note: If any part is missing from the kit, contact a Microchip sales office for assistance. A list of Microchip offices for sales and service is provided on the last page of this document.

Curiosity PIC32MZ EF 2.0 Development Board

The Curiosity PIC32MZ EF 2.0 Development Board (DM320209) is shown in the following figure:

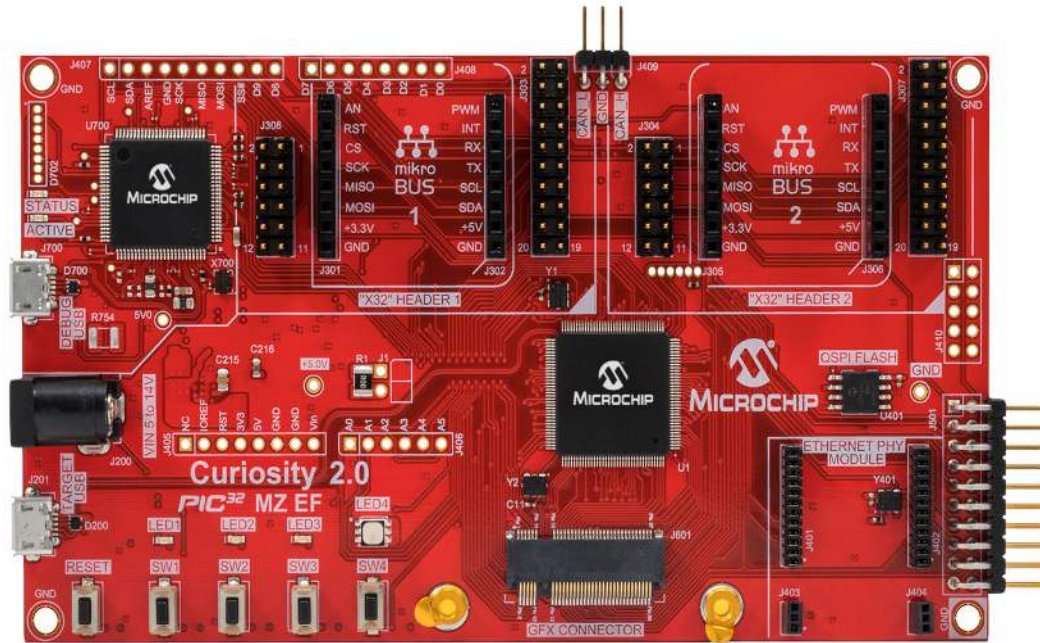

Table of Contents

Introduction.....	1
1. Curiosity PIC32MZ EF 2.0 Development Board Features.....	1
2. Kit Contents.....	1
Curiosity PIC32MZ EF 2.0 Development Board	1
1. Development Board Functionality and Features.....	4
1.1. Board Feature Location.....	4
1.2. System Block Diagram.....	5
1.3. Power Block Diagram.....	5
1.4. PICKit On-Board 4.....	6
1.5. I ² C Voltage Selection.....	8
1.6. X32 Audio Interface.....	10
1.7. mikroBUS.....	12
1.8. Control Area Network (CAN) Bus Interface.....	13
1.9. Ethernet.....	13
1.10. Xplained Pro Extension Standard Header.....	15
1.11. Graphics Connector/GFX Card Interface.....	16
1.12. Buttons and LEDs.....	19
1.13. USB.....	19
2. Hardware.....	20
2.1. Schematics.....	20
2.2. Bill of Materials.....	36
2.3. Board Dimensions.....	38
The Microchip Web Site.....	39
Customer Change Notification Service.....	39
Customer Support.....	39
Microchip Devices Code Protection Feature.....	39
Legal Notice.....	40
Trademarks.....	40
Quality Management System Certified by DNV.....	40
Worldwide Sales and Service.....	41

1. Development Board Functionality and Features

1.1 Board Feature Location

Figure 1-1. Curiosity PIC32MZ EF 2.0 Development Board Layout (Top View)

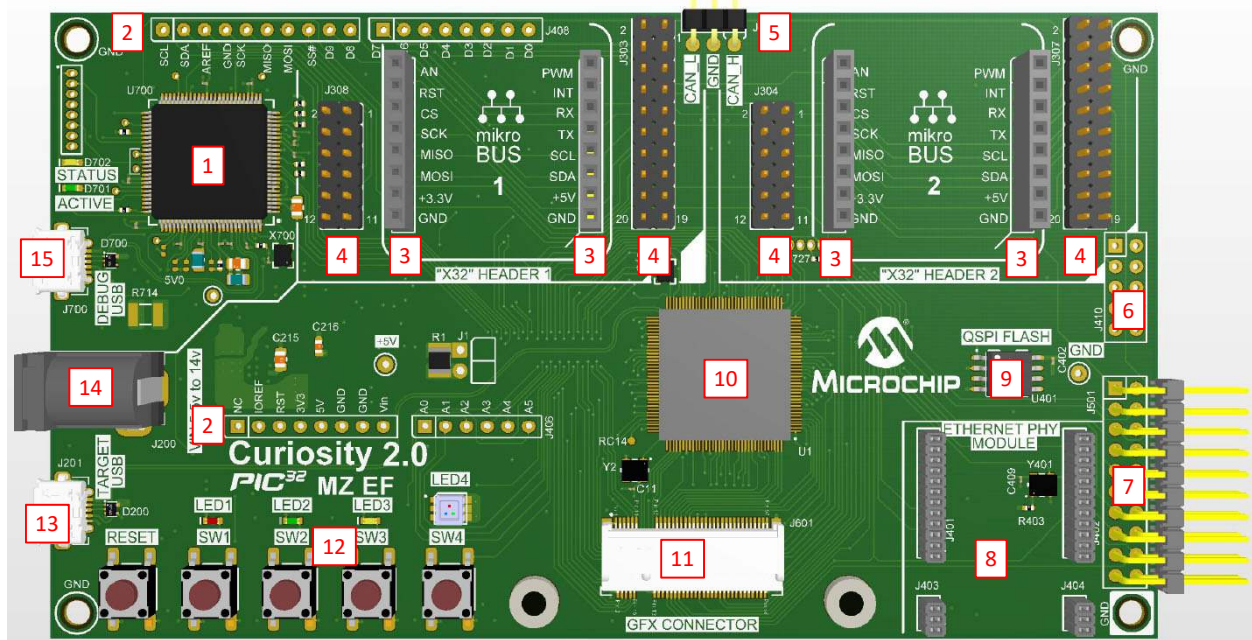

Table 1-1. Board Features and Locations

Number	Description of Item
1	PICKit on Board 4 (PKoB4)
2	Arduino Uno interface. Headers not populated
3	mikroBUS Click interface. 2 per board
4	X32 Audio interface. 2 per board. Bluetooth & Audio codecs sold separately
5	CAN interface
6	Authentication interface. Header not populated
7	Xplained pro expansion compatible interface
8	Ethernet interface (RMII, SPI, GPIO). Ethernet PHY not included.
9	Quad SPI Memory 256 Mb
10	PIC32MZ2048EFM144
11	Graphics Interface
12	Programmable user buttons & LEDs
13	USB to PIC32MZ EF
14	2.5 mm barrel jack power input

.....continued	
Number	Description of Item
15	USB to PKoB4 for debugging, power, virtual COM port

1.2 System Block Diagram

The following high-level block diagram that shows the major data bus routing.

Figure 1-2. System Block Diagram

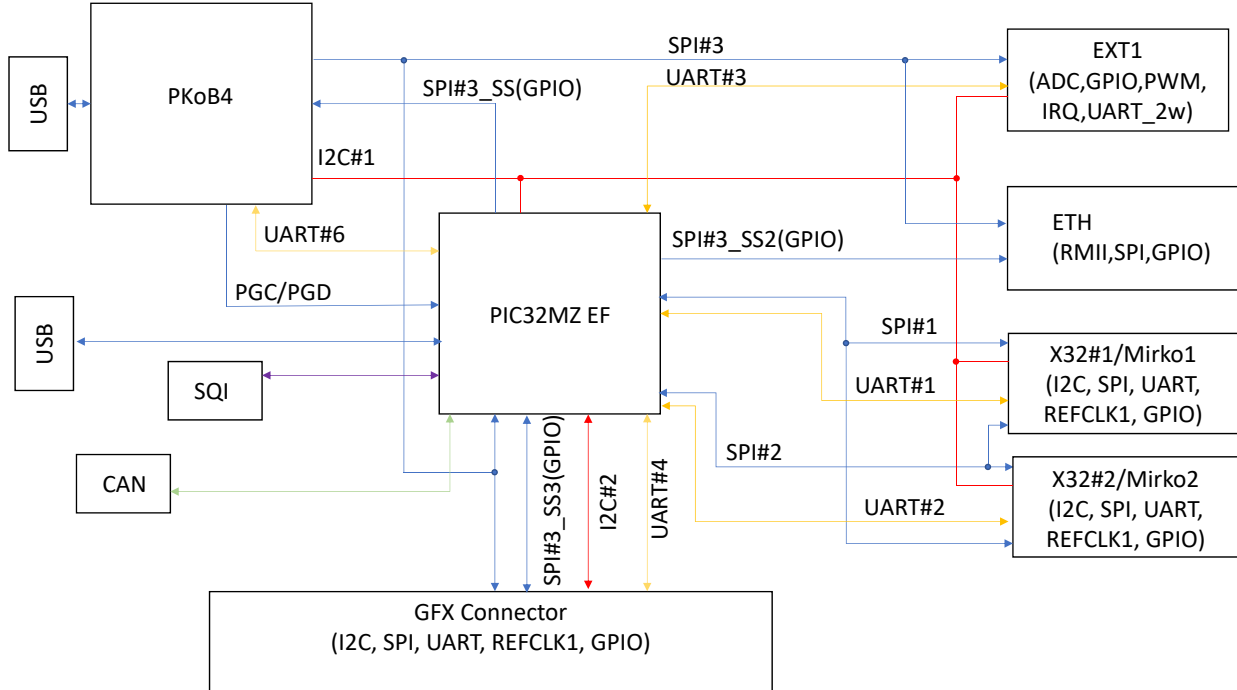

1.3 Power Block Diagram

The following figure shows a block diagram of the power system on the Curiosity PIC32MZ EF 2.0 Development Board. The Curiosity PIC32MZ EF 2.0 Development Board has several power sub systems that allow it to accept up to 16V. The barrel jack is a 2.1 mm center positive connector. The power in can also be connected through the Arduino header, this input is before the reverse voltage protection.

Figure 1-3. Power Block Diagram

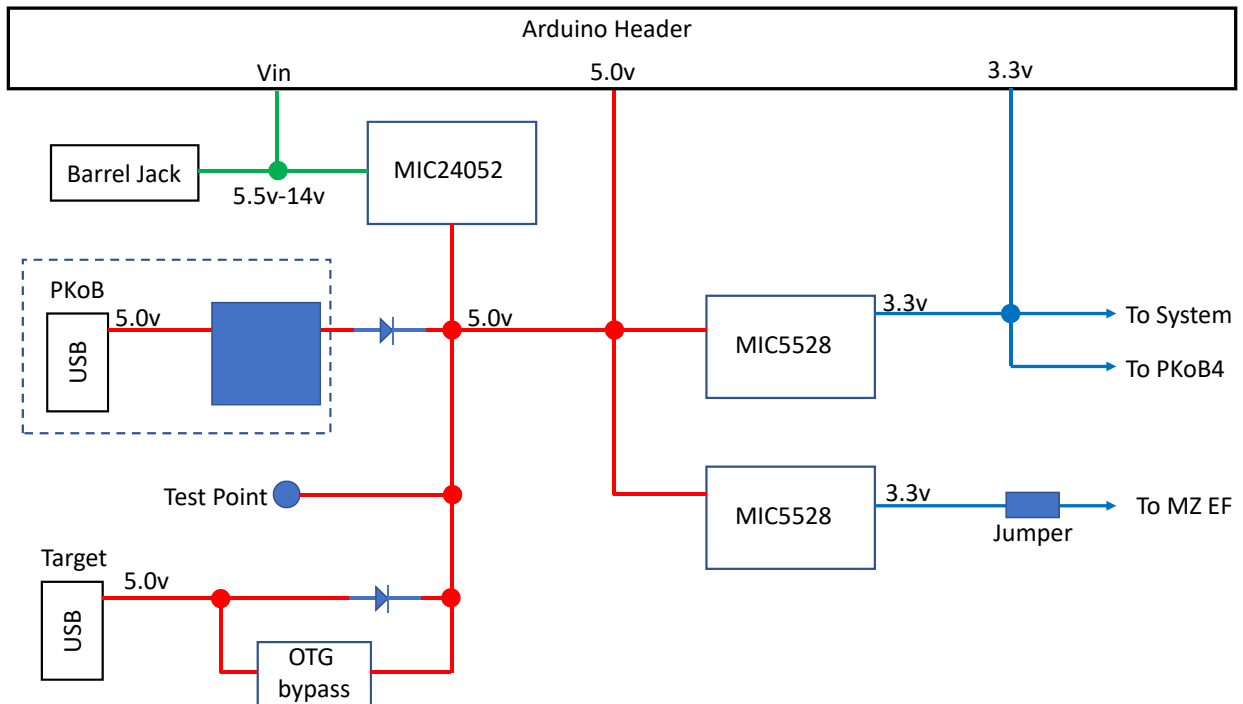

1.4 PICKit On-Board 4

The MPLAB® PICKit™ On-Board 4 (PKoB4) is a new generation of In-Circuit Debugger. The MPLAB PKoB4 programs faster than its predecessor, and is designed to use a high-speed 2.0 USB interface and provide a feature rich debugging experience through one USB cable. The PKoB4 is intended to support programming debugging and a Data Gateway interface.

The MPLAB PKoB4 In-Circuit Debugger is compatible with any of these platforms:

- Microsoft Windows® 7 or later
- Linux®
- macOS™

The MPLAB PKoB4 In-Circuit Debugger system provides the following advantages:

Features and Capabilities:

- Connects to computer through high-speed USB 2.0 (480 Mbits/s) cable
- Programs devices using MPLAB X IDE or MPLAB IPE
- Supports multiple hardware and software breakpoints, stopwatch, and source code file debugging
- Debugs your application in real time
- Sets breakpoints based on internal events
- Monitors internal file registers
- Debugs at full speed
- Configures pin drivers
- Field-upgradeable through an MPLAB X IDE firmware download
- Adds new device support and features by installing the latest version of MPLAB X IDE (available as a free download at <https://www.microchip.com/mplabx/>)
- Indicates debugger status through on-board LEDs

Performance and Speed:

- More and faster memory
- A Real-Time Operating System (RTOS)
- No firmware download delays incurred when switching devices
- A 32-bit MCU running at 300 MHz

1.4.1 Recovery Method

When the MPLAB® PICkit™ On-Board 4 is not responding, the user can recover the it by following these steps:

1. With the Curiosity PIC32MZ EF 2.0 Development Board is still powered, short the two pads for approximately 10 seconds.

Figure 1-4. Location of Pads to Short

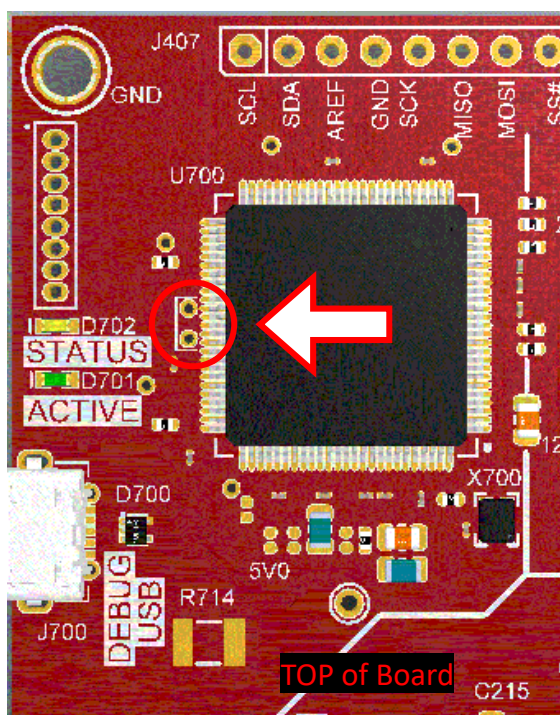
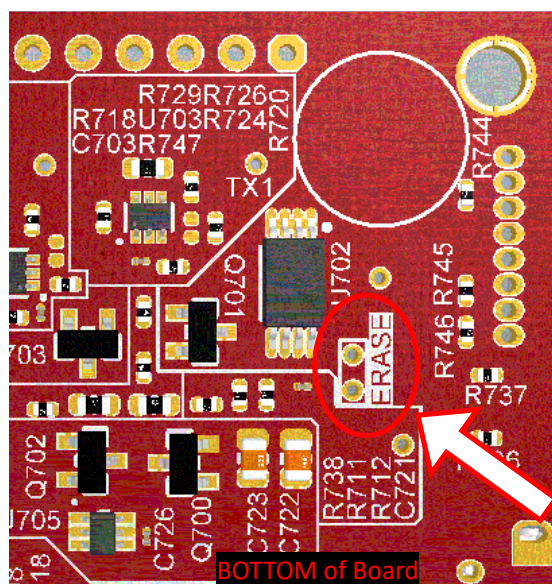

2. Open The latest version of MPLAB X.
3. Click on *Debug > Hardware Tool Emergency Boot Firmware Recovery*.

Figure 1-5. Debugging Window

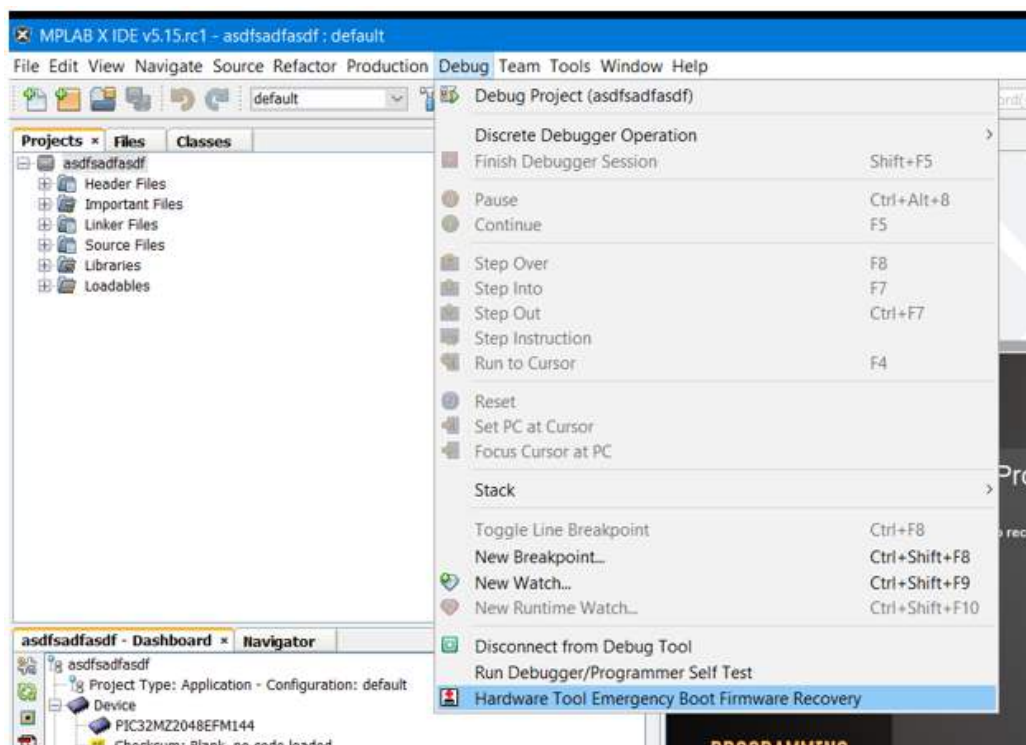

4. Follow the directions on the screen. This will bring the tool back to the factory conditions.

For additional information on the PKoB4, refer to the “MPLAB® PICKit™ 4 In-Circuit Debugger User’s Guide” (DS50000251), which is available for download at <http://ww1.microchip.com/downloads/en/DeviceDoc/MPLAB%20PICKit%204%20ICD%20Users%20Guide%20DS50002751C.pdf>

1.5 I²C Voltage Selection

The I²C voltage is defaulted to 3.3-volt pull ups. A 5.0-volt option is possible. In order to do this the trace must be cut and a resistor of 0 ohm or a bus bar must be installed. A 0805 SMD footprint has been provided. This is located on the back side of the board. The following figure shows the I²C jumper in the trace:

Figure 1-6. I²C Jumper

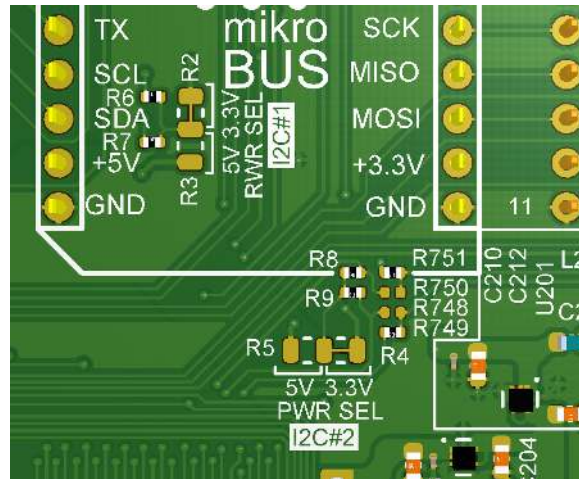

The following figure shows the schematic representation:

Figure 1-7. Schematic Representation

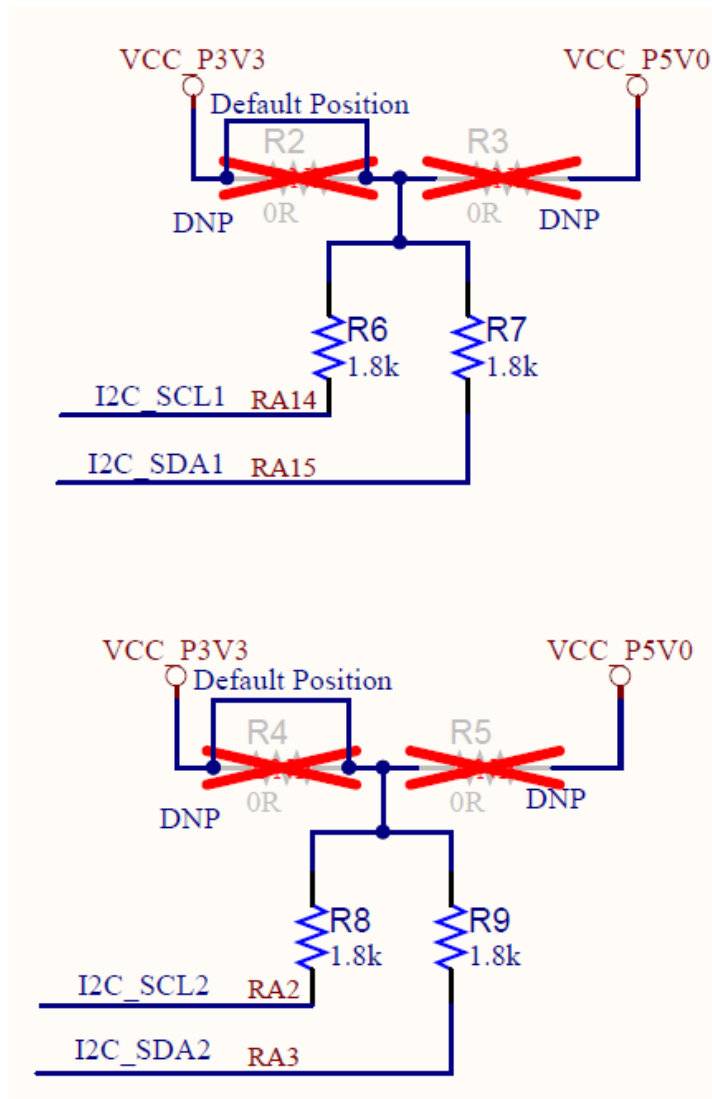

1.6 X32 Audio Interface

The X32 is a 32-pin interface to the board to support audio codec, DACs, and Bluetooth radios. This interface has audio supply I²S and other control lines, and data interfaces.

1.6.1 Block Diagram

The Curiosity PIC32MZ EF 2.0 Development Board has two X32 interfaces that share two I²S signals. The following figure shows the relation between the I²S signals and the X32 daughter board interface.

Figure 1-8. X32 Interface Block Diagram

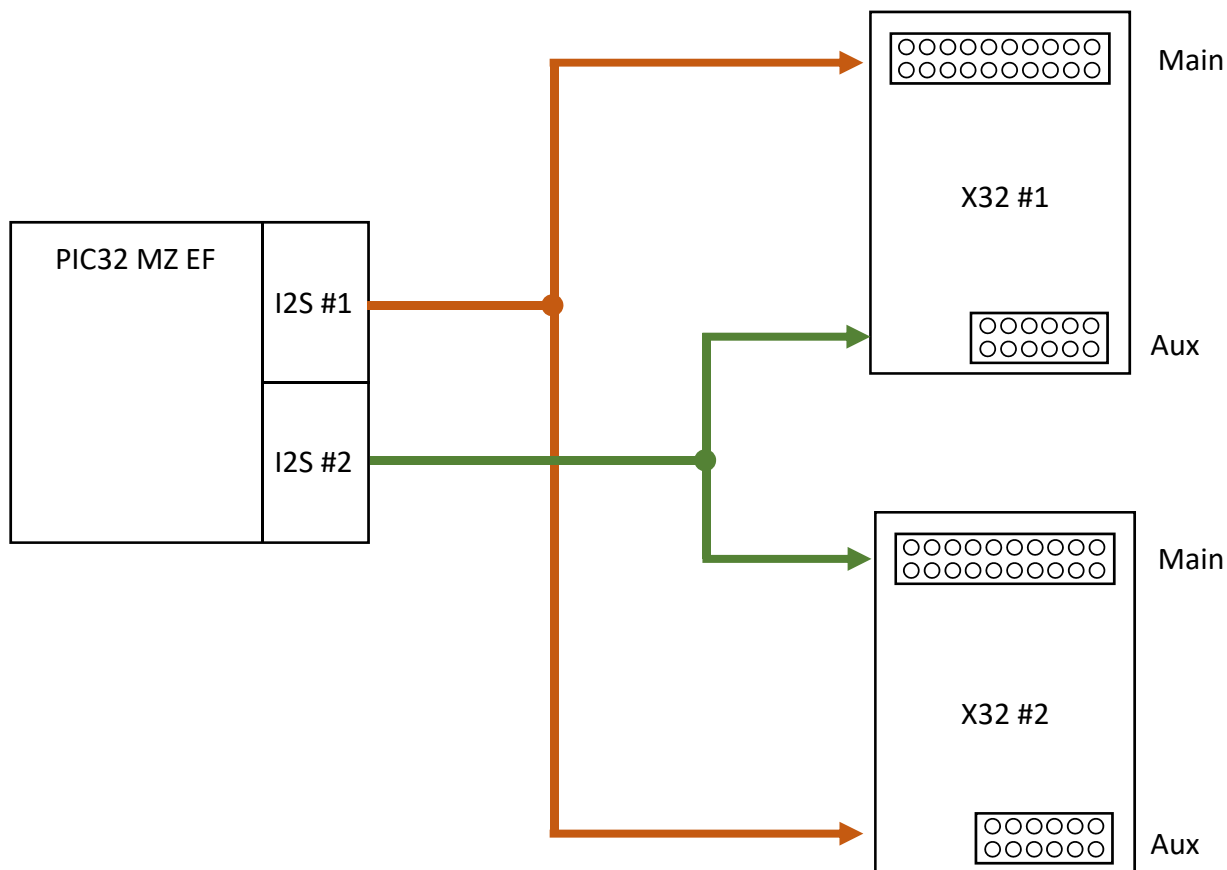

1.6.2 Pinout

The following table shows the pinout and description for the X32 Audio interface. Refer to the Schematics for additional information.

Table 1-2. X32 Audio Interface Pinout

Pin Number	Name	Description	Interface
1	GND	Ground	Power
2	GND	Ground	Power
3	UART RX	UART RX, receive to MCU from DB	UART
4	UART CTS	UART Clear to send	UART
5	UART TX	UART TX, transmit from MCU to DB	UART

Development Board Functionality and Features

.....continued			
Pin Number	Name	Description	Interface
6	UART RTS	UART Ready to send	UART
7	I ² C SCL	Clock line for I ² C interface.	I ² C
8	STBY/RST	Standby/Reset control	GPIO
9	I ² C SDA	Data line for I ² C interface.	I ² C
10	Audio WS/LRCLK	Audio Word Select/Left Right Clock	I ² S
11	Audio In	Audio into MCU, out from CODEC	I ² S
12	Audio CLK	Audio clock	I ² S
13	Audio out	Audio out of MCU, in to CODEC/DAC	I ² S
14	REFCLK/MCK	Reference clock #1	REFCLK
15	GND	Ground	Power
16	GND	Ground	Power
17	NC	Legacy hold over	-
18	+3.3v	VDD	Power
19	NC	Legacy hold over	-
20	+5.0v	VDD	Power
21 (1)	Audio WS/ Audio LRCLK	Audio Word Select/Left Right Clock	I ² S
22 (2)	Card ID pin	Communication line to the daughter card and PKoB4.	Connected to PKoB4
23 (3)	Audio CLK	Audio Clock	I ² S
24 (4)	NC		
25 (5)	Audio IN	Audio into MCU, out from CODEC	I ² S
26 (6)	NC		
27 (7)	Audio OUT	Audio out of MCU, in to CODEC/DAC	I ² S
28 (8)	NC		
29 (9)	REFCLK2/MCK2	Reference clock #2	REFCLK
30 (10)	NC		
31 (11)	GND	Ground	Power
32 (12)	GND	Ground	Power

1.6.3 Port Connections

The following table provides the port and connections to the X32 Audio interface. The I²S signals listed are the main signals, and both of these signals are available at each interface, refer to the X32 Interface [Block Diagram](#) for additional information.

Table 1-3. Port Connections

Interface	X32#1	X32#2
UART RX	RPC4	RPE9
UART TX	RPC1	RPG9

Development Board Functionality and Features

.....continued		
Interface	X32#1	X32#2
UART RTS	RPE8	RPF5
UART CTS	RPF12	RPD10
I ² C SDA	RA3	RA3
I ² C SCL	RA2	RA2
Reset	RJ12	RJ10
REFCLK	RPD15	RPD15
I ² S Clock	RPD1	RPG6
I ² S Audio Out (MOSI)	RPD7	RPG8
I ² S Audio In (MISO)	RPD14	RPG7
I ² S LRCLK	RPD9	RPC2

1.7 mikroBUS

The mikroBUS interface allows for the use of additional click™ boards. For additional information and to see the boards which can be used with this development board, refer to: <https://www.mikroe.com/>.

Table 1-4. mikroBUS™ Pinout

Pin Number	Name	Function
1	GND	Ground
2	+5V	+5.0V
3	SDA	I2C SDA
4	SCL	I2C SCL
5	TX	UART TX
6	RX	UART RX
7	INT	Interrupt request line
8	PWM	Pulse width modulation
9	GND	Ground
10	+3.3V	Ground
11	MOSI	Master Out Slave In line of serial peripheral interface.
12	MISO	Master In Slave Out line of serial peripheral interface.
13	SCK	Clock for serial peripheral interface
14	CS	Chip Select for serial peripheral interface. (Active low)
15	RST	Reset
16	AN	Analog-to-digital converter.

1.7.1 Port Connections

The following table provides the port connections to the mikroBUS interface. The mikroBUS is nested inside of the X32 Audio interface. Due to mechanical interference, either a mikroBUS or Audio interface can be used in the same

socket. The mikroBUS interface shares signals with the X32 Audio interface, refer to [Pinout](#) for additional information on pinout or signal probing.

Table 1-5. Port Connections for the mikroBUS Interface

Interface	mikroBUS™ #1	mikroBUS™ #2
UART RX	RPC4	RPE9
UART TX	RPC1	RPG9
INT/IRQ	RPF12	RPD10
I ² C SDA	RA3	RA3
I ² C SCL	RA2	RA2
Reset	RJ12	RJ10
PWM	RPD15	RPD15
SPI Clock	RPD1	RPG6
SPI MOSI	RPD7	RPG8
SPI MISO	RPD14	RPG7
SPI SS	RPD9	RPC2
ADC	AN5	AN6

1.8 Control Area Network (CAN) Bus Interface

The Curiosity PIC32MZ EF 2.0 Development Board provides access to a CAN interface that is post transceiver. The on-board CAN transceiver is an ATA6561, which allows the application to be used directly with any CAN bus compliant interface.

Table 1-6. CAN Bus Interface

Pin Number	Name	Description	Port
1	CAN_H	CAN High Signal	-
2	GND	Ground	-
3	CAN_L	CAN Low Signal	-
-	CAN2_TX	CAN Transmit	RPD5
-	CAN2_RX	CAN Receive	RPF5

1.9 Ethernet

The Curiosity PIC32MZ EF 2.0 Development Board has a modular Ethernet PHY system that enables different PHYs to be plugged into the board. This interface is set up to use a Reduced Media-Independent Interface (RMII interface) and a SPI bus interface with GPIO.

Development Board Functionality and Features

Figure 1-9. Ethernet PHY Header Configuration

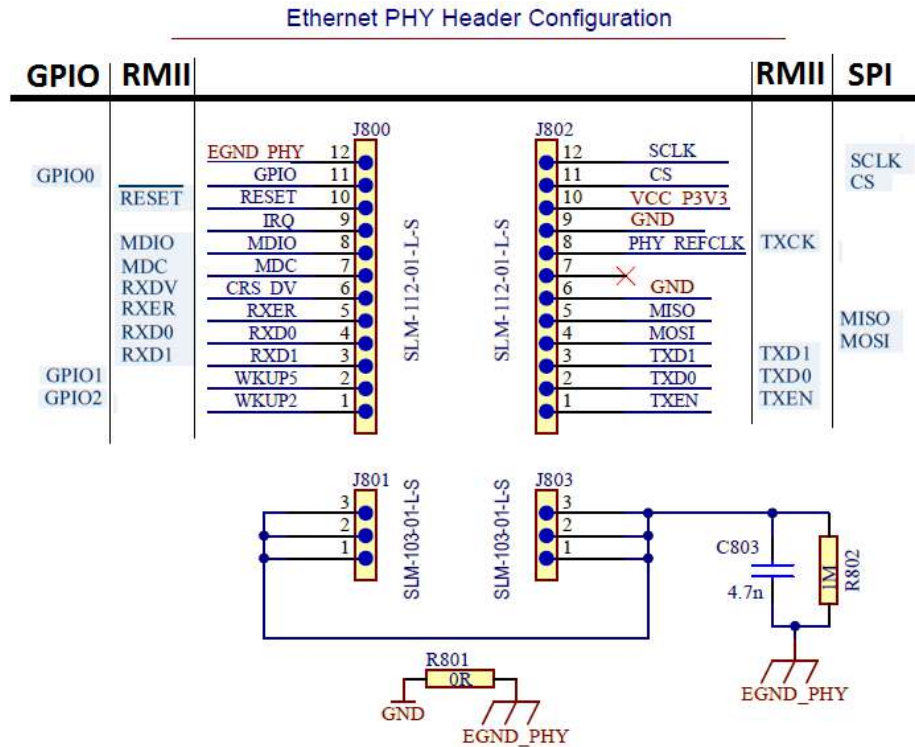

The following table provides the pinout and description of the Ethernet interface:

Table 1-7. Pinout and Description for the Ethernet Interface

Pin Number	Name	Description	Port
1	GPIO	General purpose I/O	RH15
2	GPIO	General purpose I/O	RH14
3	RXD1	Receive Data 1	RH5
4	RXD0	Receive Data 0	RH8
5	RXER	Receive Error	RH4
6	RXDV	Receive Data Valid	RH13
7	MDC	Ethernet Management Data Clock	RD11
8	MDIO	Ethernet Management Data	RJ1
9	IRQ	Interrupt request line	RJ2
10	RESET	Reset control to the Ethernet PHY	RJ0
11	GPIO	General purpose I/O	RH12
12	EGND	Shield Ground	-
13 (1)	TXEN	Transmit Enable	RD6
14 (2)	TXD0	Transmit Data	RJ8
15 (3)	TDX1	Transmit Data	RJ9
16 (4)	MOSI	Master Out Slave In line of serial peripheral interface.	RB3

.....continued

Pin Number	Name	Description	Port
17 (5)	MISO	Master In Slave Out line of serial peripheral interface	RB5
18 (6)	GND	Ground	-
19 (7)	NC	No Connect	-
20 (8)	REFCLK (in)	Reference Clock input (50MHz)	RJ11
21 (9)	GND	GND	-
22 (10)	+3.3v VDD	+3.3V VDD	-
23 (11)	CS	Chip Select for serial peripheral interface	RH3
24 (12)	SCK	Clock for serial peripheral interface	RB14
25 -30	EGND	Shield Ground	-

1.10 Xplained Pro Extension Standard Header

The Curiosity PIC32MZ EF 2.0 Development Board has an Xplained Pro extension compatible interface that enables using the existing extension boards. This interface consists of a dual row, 20-pin, 100 mil, 90 degree extension male header. Xplained Pro extensions have their female counterparts. The extension headers can be used to connect a variety of Xplained Pro extension boards or to access the pins of the target MCU directly. All connected pins follow the defined pinout description as shown in the following table.

Note: All pins are not always connected.

Table 1-8. Interface Pinout

Pin number	Name	Description	Port
1	ID	Communication line to the ID chip on an extension board	Connected to PKoB4
2	GND	Ground	-
3	ADC(+)	Analog-to-digital converter, alternatively positive part of differential ADC	RB2/AN2
4	ADC(-)	Analog-to-digital converter, alternatively negative part of differential ADC	RB12/AN7
5	GPIO1	General purpose I/O	RK4
6	GPIO2	General purpose I/O	RK5
7	PWM(+)	Pulse width modulation, alternatively positive part of differential PWM	No Connect
8	PWM(-)	Pulse width modulation, alternatively negative part of differential PWM	No Connect
9	IRQ/INT/GPIO	Interrupt request line and/or general purpose I/O	RK0
10	SPI SS B/GPIO	SPI Slave Select or General purpose I/O	RK6
11	I ² C SDA	Data line for I ² C interface. Always implemented, bus type	RA15
12	I ² C SCL	Clock line for I ² C interface. Always implemented, bus type.	RA14

.....continued

Pin number	Name	Description	Port
13	UART RX	Receiver line of target device UART	RPD15
14	UART TX	Transmitter line of target device UART.	RPF4
15	SPI SS A/GPIO	SPI Slave Select or General purpose I/O	RPB15
16	SPI MOSI	Master Out Slave In line of serial peripheral interface. Always implemented, bus type.	RPB3
17	SPI MISO	Master In Slave Out line of serial peripheral interface. Always implemented, bus type.	RPB5
18	SPI SCK	Clock for serial peripheral interface. Always implemented, bus type	RPB14
19	GND	Ground	-
20	VCC	Power for extension boards (3.3V)	-

Figure 1-10. Pinout Schematic

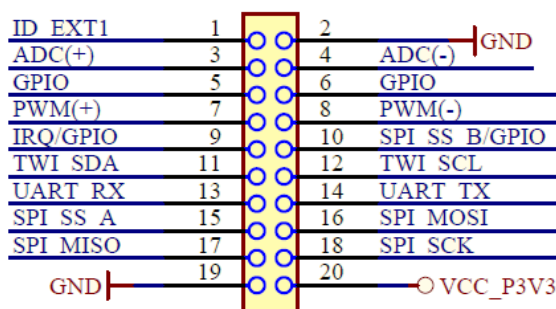

1.11 Graphics Connector/GFX Card Interface

The Curiosity PIC32MZ EF 2.0 Development Board has a new graphics interface that enables using different graphics cards to support different graphics models.

Table 1-9. Graphics Pinout

Pin Number	Name	Description	Port
1	GND	Ground	-
2	GND	Ground	-
3	MCLR	Master Clear, controlled by the debuggers. allows for a complete system reboot	-
4	IRQ1 (LCD Touch)	Interrupt request line for cap touch device	RD0
5	5.0V VCC	5.0V	-
6	IRQ2 (Q Touch)	Interrupt request line for Q touch devices	RH9
7	LCDEN	LCD Data Enable	RK3
8	IRQ3 (Display Controllers)	Interrupt request line for external display controllers	RH10

Development Board Functionality and Features

.....continued

Pin Number	Name	Description	Port
9	LCDHSYNC/NCS3	LCD Horizontal Sync	RK1
10	IRQ4 (Resistive touch)	Interrupt request line for resistive touch controllers	RH11
11	LCDVSYNC/nWE	LCD Vertical Sync or Write enable (active low)	RK2
12	5.0V VCC	+5.0V	-
13	LCDPCK/nRD	LCD pixel Clock or Read Enable (active low)	RC3
14	I ² C SDA	Data line for I ² C interface. Always implemented, bus type	RA3
15	LCD D0	LCD Data bit 0	RE0
16	I2C SCL	Clock line for I ² C interface. Always implemented, bus type.	RA2
17	LCD D1	LCD Data bit 1	RE1
18	SPI SCK	Clock for serial peripheral interface. Always implemented, bus type	RPB14
19	LCD D2	LCD Data bit 2	RE2
20	SPI MOSI	Master Out Slave In line of serial peripheral interface.	RPB3
21	LCD D3	LCD Data bit 3	RE3
22	SPI MISO	Master In Slave Out line of serial peripheral interface.	RPB5
23	LCD D4	LCD Data bit 4	RE4
24	SPI SS	SPI Slave Select	RH2
25	LCD D5	LCD Data bit 5	RE5
26	UART RX	Receiver line of target device UART (Not Implemented on this design)	No Connect
27	LCD D6	LCD Data bit 6	RE6
28	UART TX	Transmitter line of target device UART. (from MCU to GFX card) (Not Implemented on this design)	No Connect
29	LCD D7	LCD Data bit 7	RE7
30	UART RTS	UART Ready To Send (from MCU to GFX card) (Not Implemented on this design)	No Connect
31	LCD D8	LCD Data bit 8	RG0
32	UART CTS	UART Clear To Send (from MCU to GFX card) (Not Implemented on this design)	No Connect
333	LCD D9	LCD Data bit 9	RG1
34	LCD PWM	LCD PWM back light control	RPB6/OC1
35	LCD D10	LCD Data bit 10	RF1
36	PWM2	Pulse width modulation,	RPD15
37	LCD D11	LCD Data bit 11	RF0

Development Board Functionality and Features

.....continued

Pin Number	Name	Description	Port
38	GPIO1	General purpose I/O	RK4
39	LCD D12	LCD Data bit 12	RD12
40	GPIO2	General purpose I/O	RK5
41	LCD D13	LCD Data bit 13	RD13
42	GPIO3	General purpose I/O	RA4
43	LCD D14	LCD Data bit 14	RD2
44	STBY/RST/GPIO4	Standby/reset or General purpose I/O. for resetting devices attached to the GFX connector	RJ14
45	LCD D15	LCD Data bit 15	RD3
46	STBY/RST/GPIO5	Standby2/Reset2 or General purpose I/O	RJ15
47	LCD D16	LCD Data bit 16 (Not implemented on this design)	No Connect
48	ID pin	Communication line to the ID chip on an extension board	Connected to PKoB4
49	LCD D17	LCD Data bit 17 (Not implemented on this design)	No Connect
50	ADC 0	Analog-to-digital converter (ADC) to MCU	AN23
51	LCD D18	LCD Data bit 18 (Not implemented on this design)	No Connect
52	ADC1	ADC to MCU	AN24
53	LCD D19	LCD Data bit 19 (Not implemented on this design)	No Connect
54	ADC2	ADC to MCU	AN27
55	LCD D20	LCD Data bit 20 (Not implemented on this design)	No Connect
56	ADC3	ADC to MCU	AN28
57	LCD D21	LCD Data bit 21 (Not implemented on this design)	No Connect
58	ADC4	ADC to MCU	AN34
59	LCD D22	LCD Data bit 22	No Connect
60	ADC5	ADC to MCU (Not implemented on this design)	No Connect
61	LCD D23	LCD Data bit 23 (Not implemented on this design)	No Connect
62	ADC6	ADC to MCU (Not implemented on this design)	No Connect
63	3.3V VCC	+3.3V VCC	-
64	ADC7	ADC to MCU (Not implemented on this design)	No Connect
65	GND	Ground	-
66	3.3V VCC	+3.3V VCC	-
67	GND	Ground	-
68	GND TAB	Mounting Tab	-
69	GND TAB	Mounting Tab	-

1.12 Buttons and LEDs

The Curiosity PIC32MZ EF 2.0 Development Board offers several user buttons and LEDs. Some of the LEDs can be used with PWM (Output Compare). The following table shows the function, description and the port on the MCU.

Table 1-10. Functions for Buttons and LEDs

Function	Description	Type	Port
SW1	Users switch	Input	RJ4
SW2	Users switch	Input	RJ5
SW3	Users switch	Input	RJ6
SW4	Users switch	Input	RC15
RESET	Hard reset of the PIC32	Input	-
LED1	User programmable LED. Single color	GPIO Output	RJ7
LED2	User programmable LED. Single color	GPIO Output	RK7
LED3	User programmable LED. Single color	GPIO Output	RJ3
LED4 (Red)	RGB LED Red channel	GPIO or PWM	RPB7 or OC8
LED4 (Green)	RGB LED Green Channel	GPIO or PWM	RPB8 or OC5
LED4 (Blue)	REB LED Blue Channel	GPIO or PWM	RPB9 or OC3

1.13 USB

The Curiosity PIC32MZ EF 2.0 Development Board has a high-speed USB 2.0 connection for user application. This port can act as either a device class or host class.

For Device class, use the USB cable which can be plugged into the target USB. Refer to [1.1 Board Feature Location](#) for additional information.

For host device class operation, a USB OTG cable is needed. To enable power from the Curiosity PIC32MZ EF 2.0 Development Board, the user must control the VBUS Enable pin. The Curiosity PIC32MZ EF 2.0 Development Board must be powered through an external source, Vin, PKoB4, or barrel jack.

Table 1-11. VBUS Enable Pin Description

Function	Description	Port
VBUS Enable	Enable power control to USB devices attached to the Curiosity PIC32MZ EF 2.0 Development Board.	RJ13

2. Hardware

2.1 Schematics

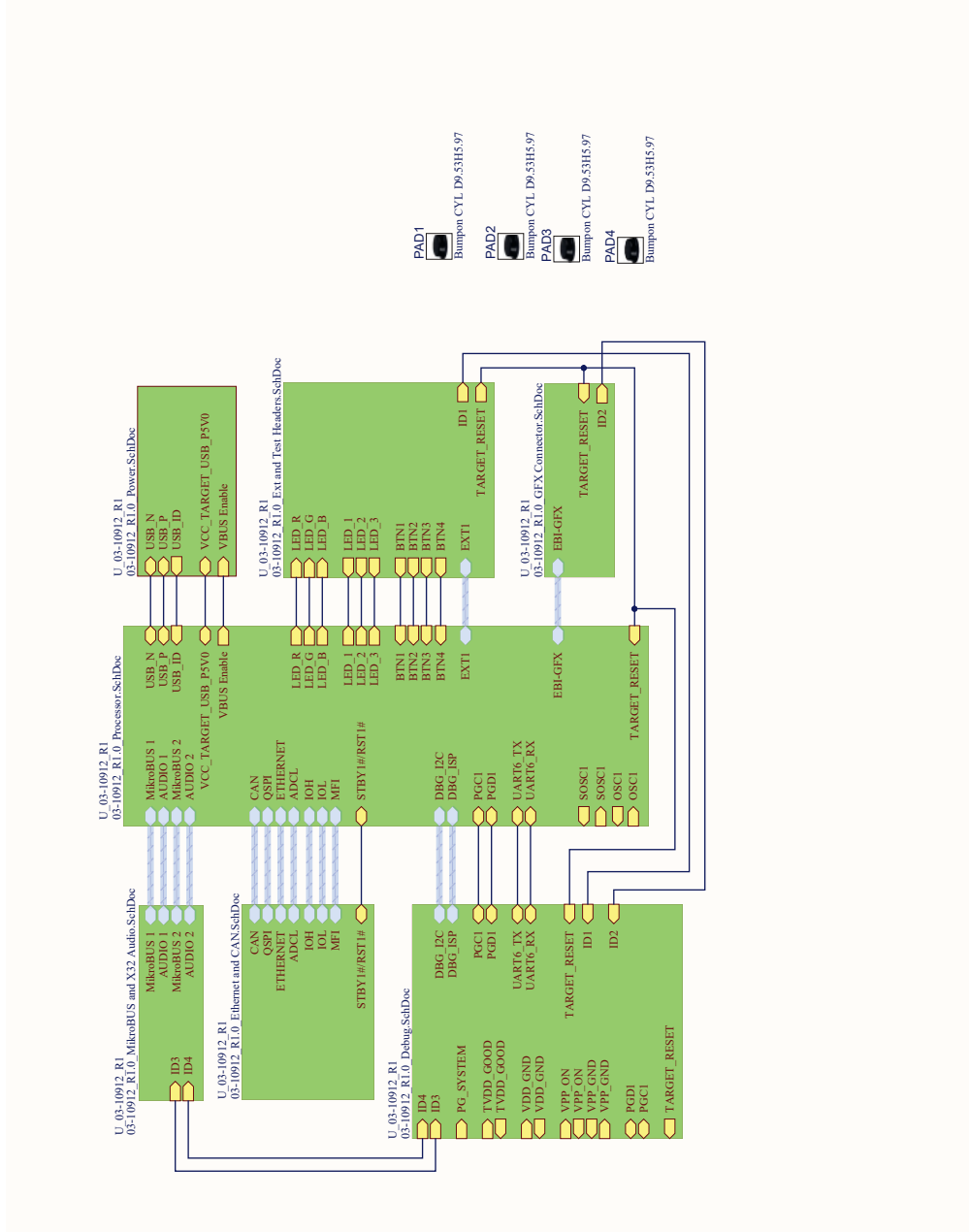

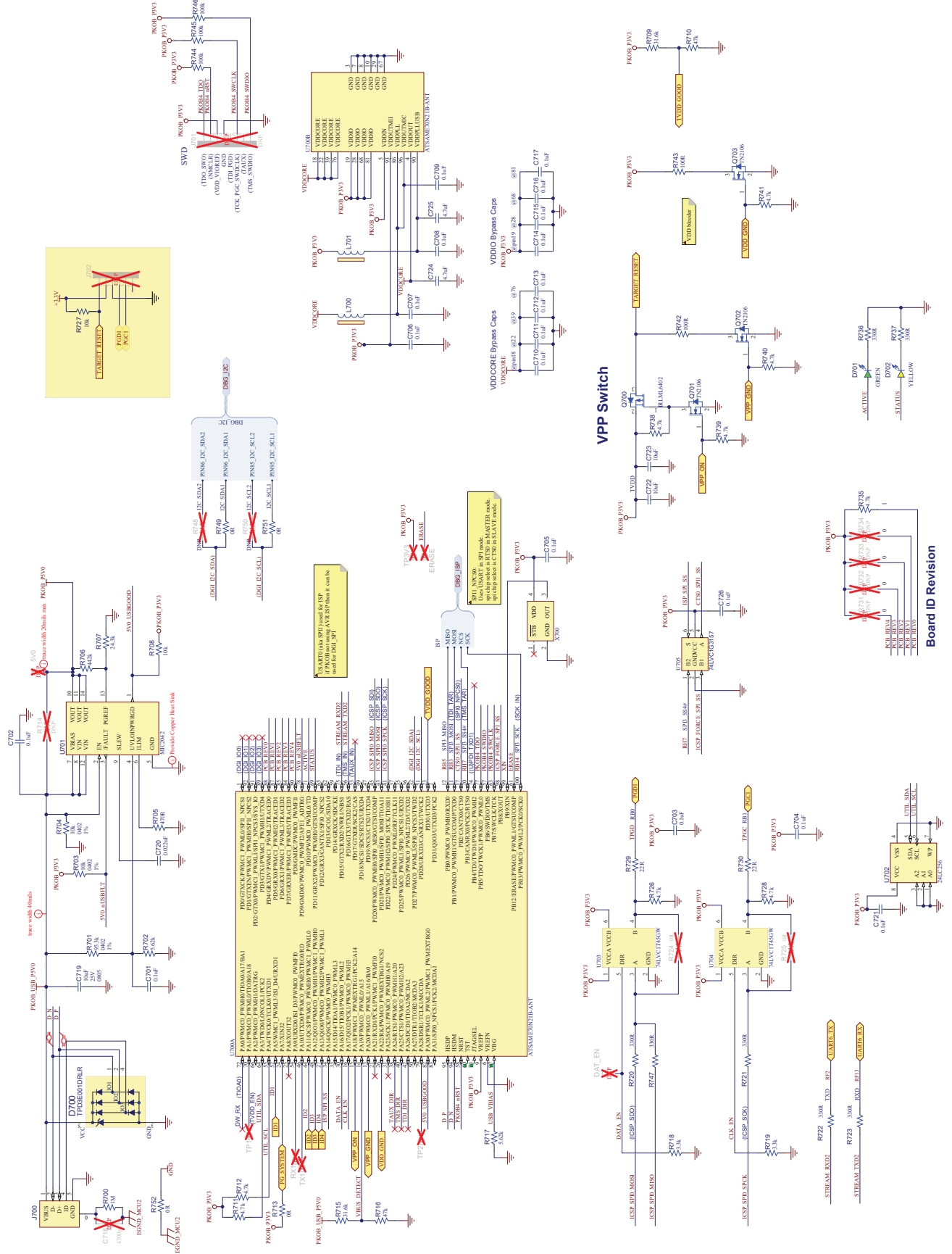

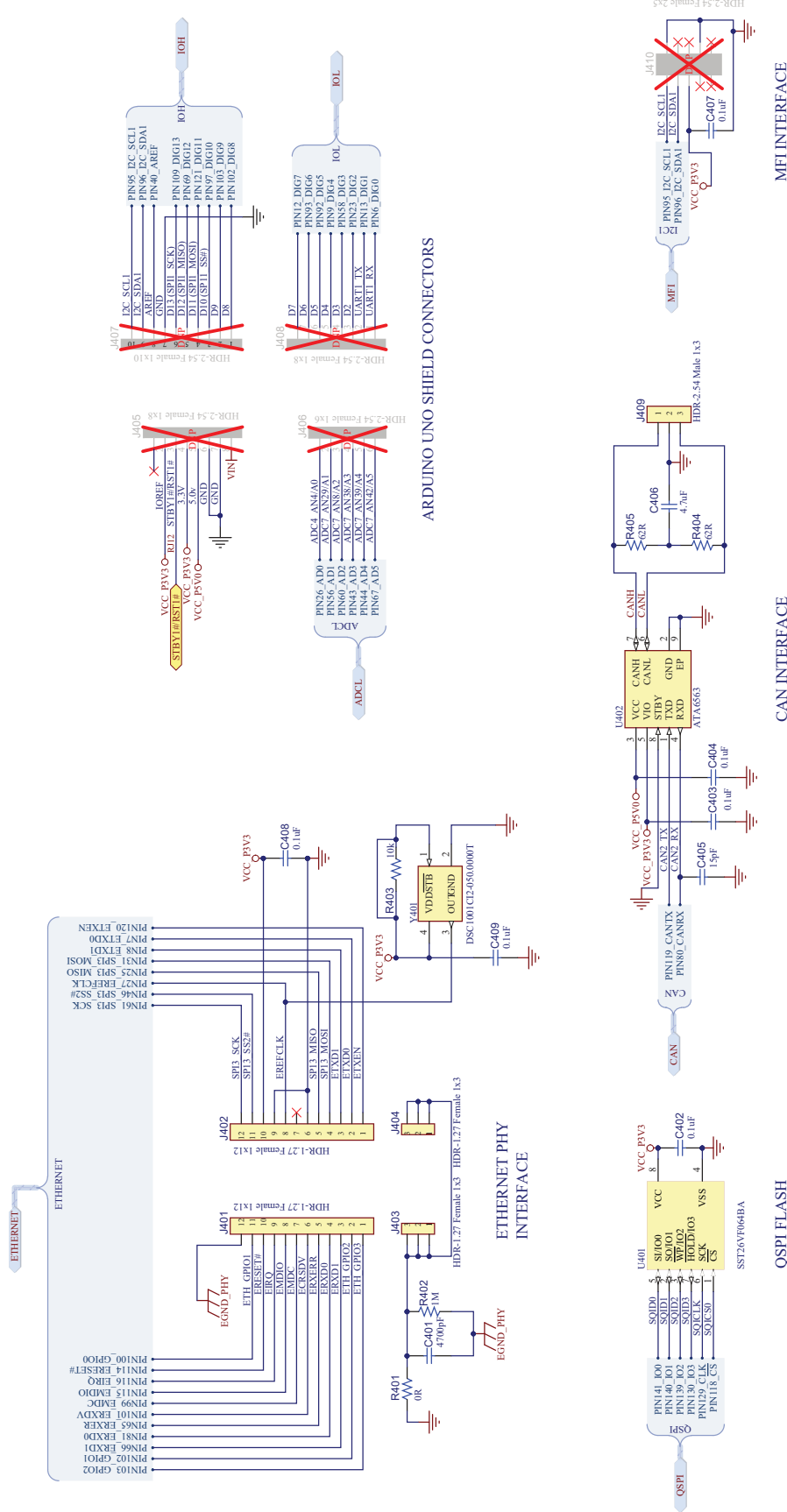

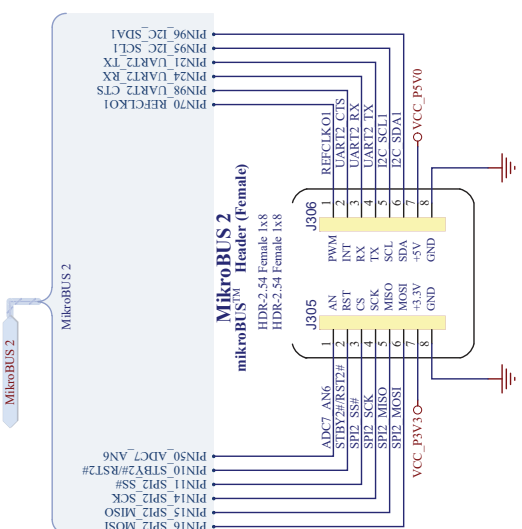
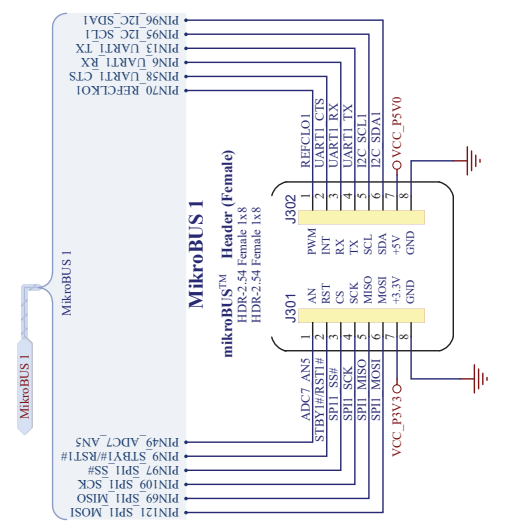
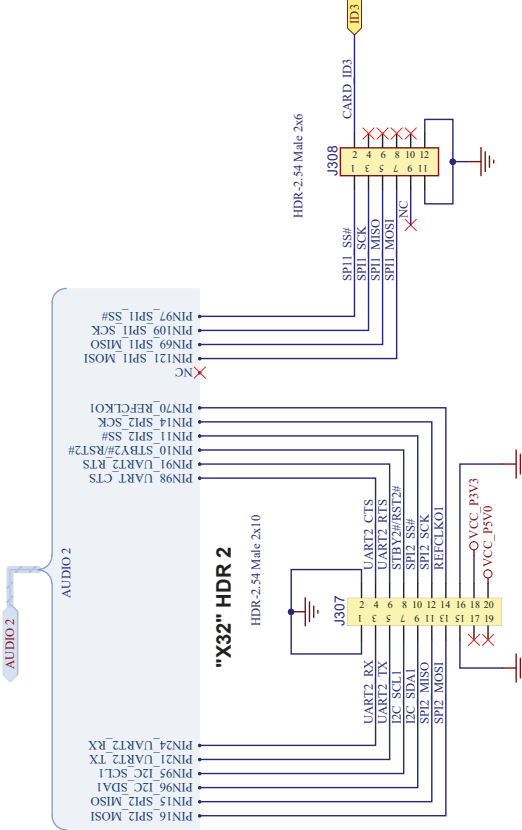
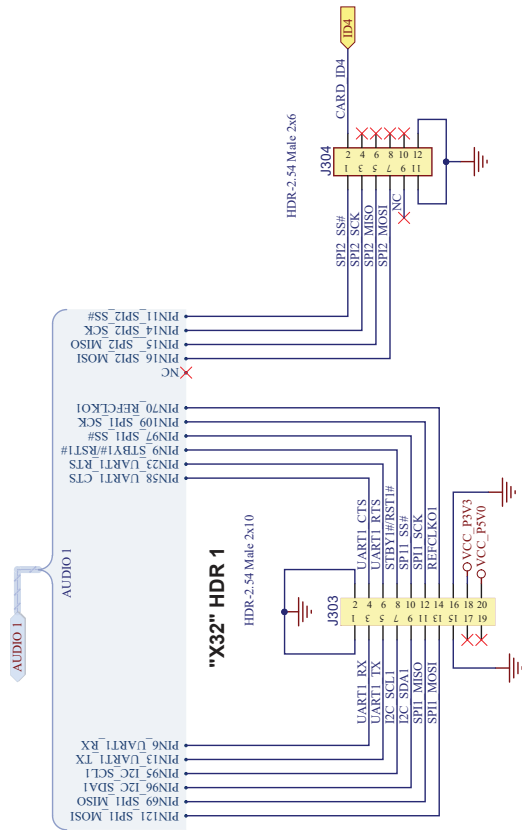

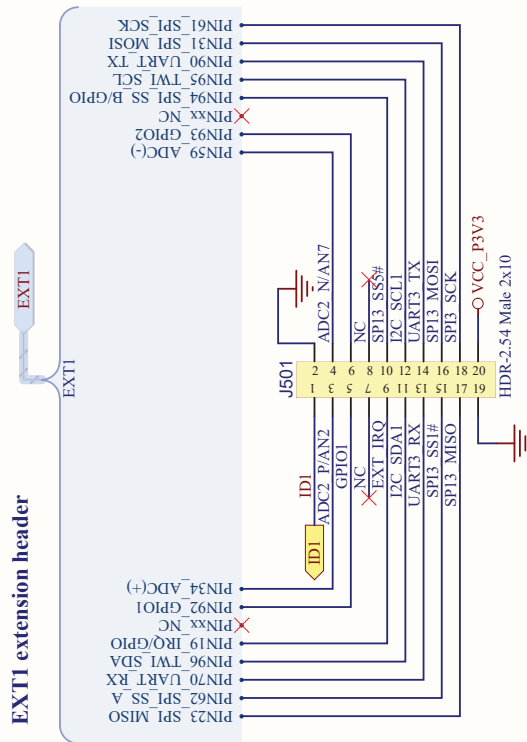
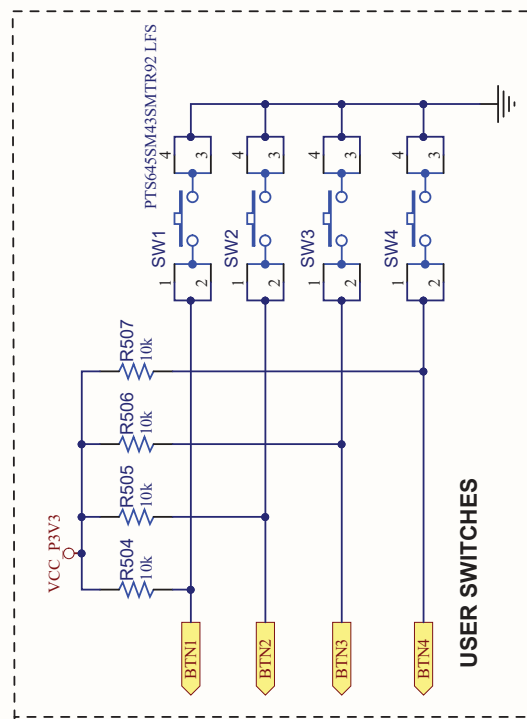
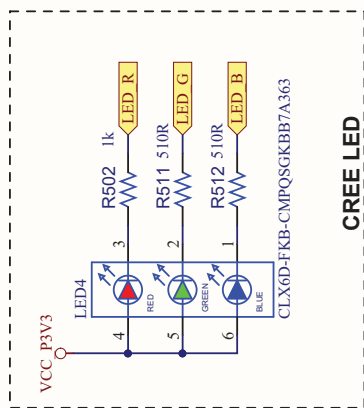
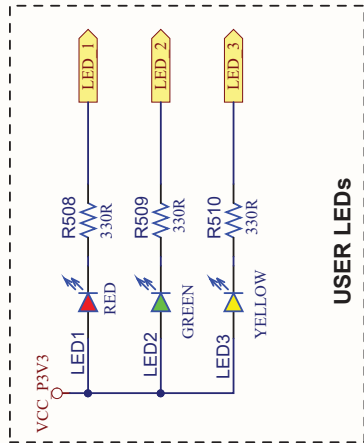
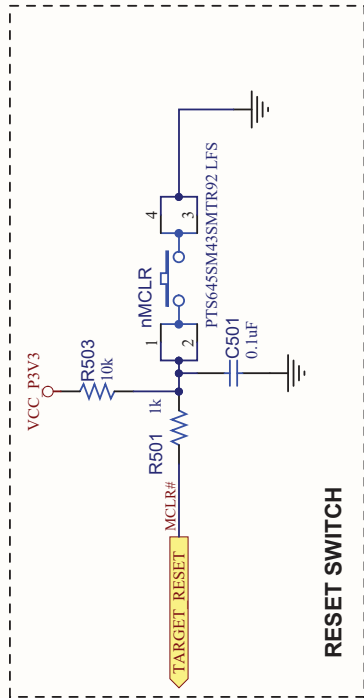

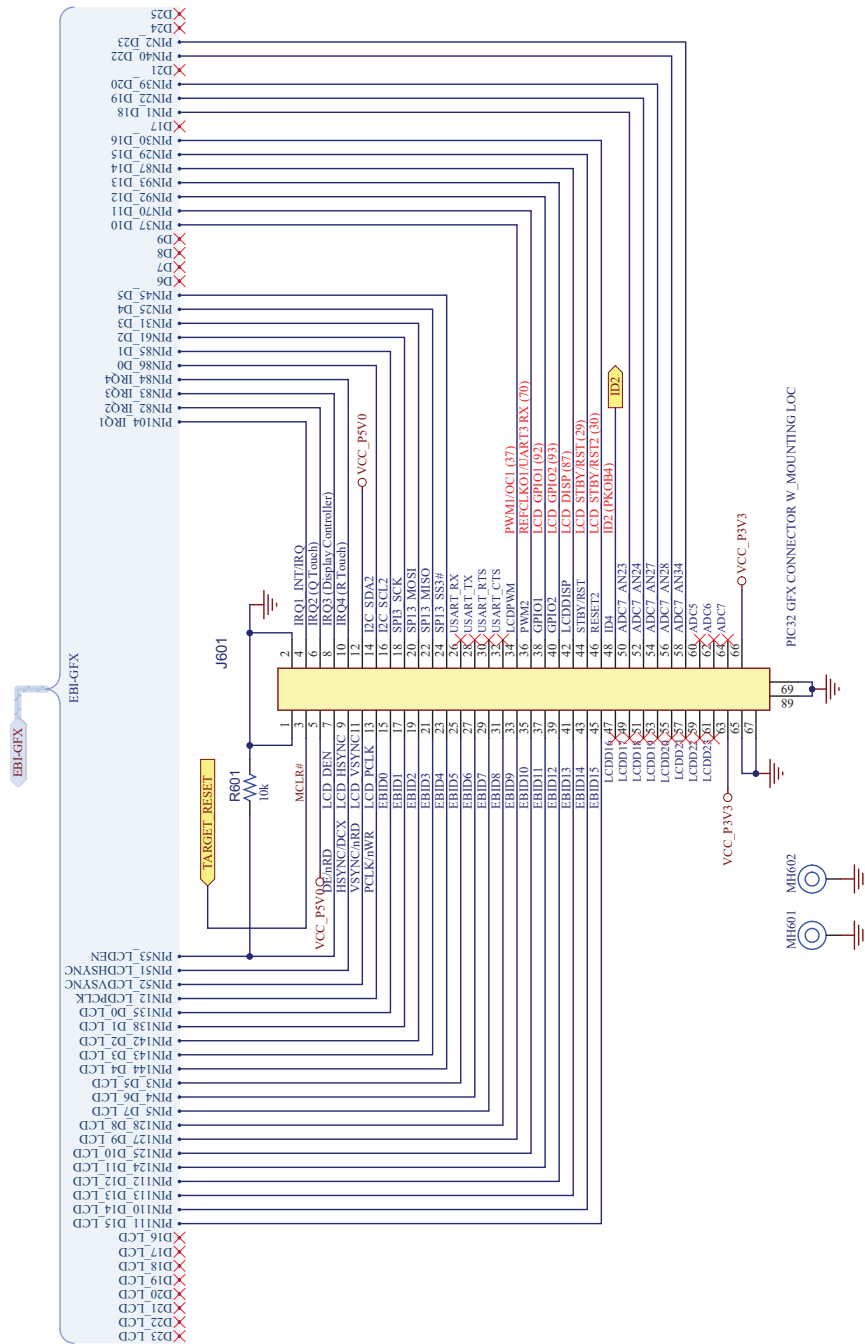

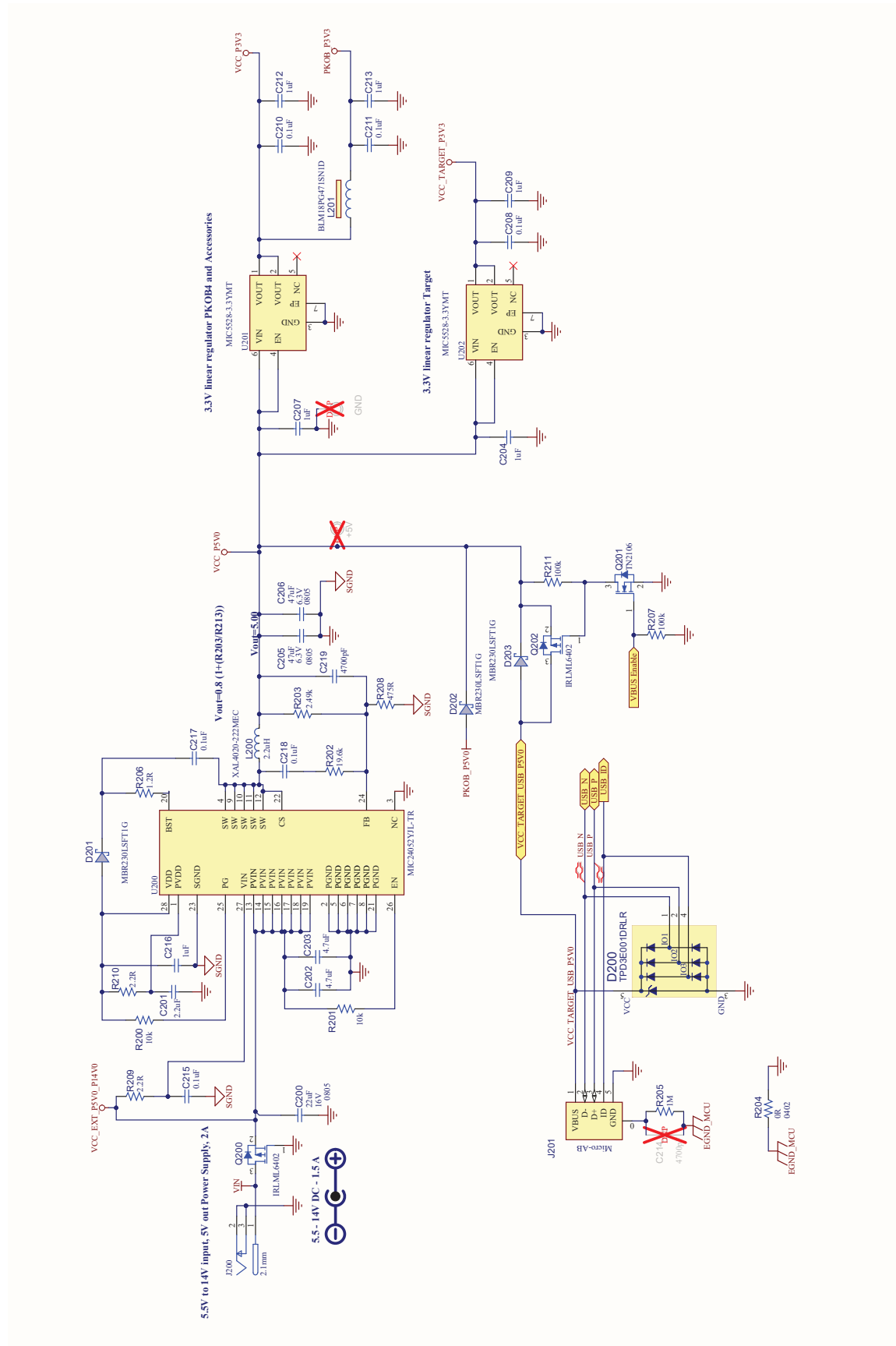

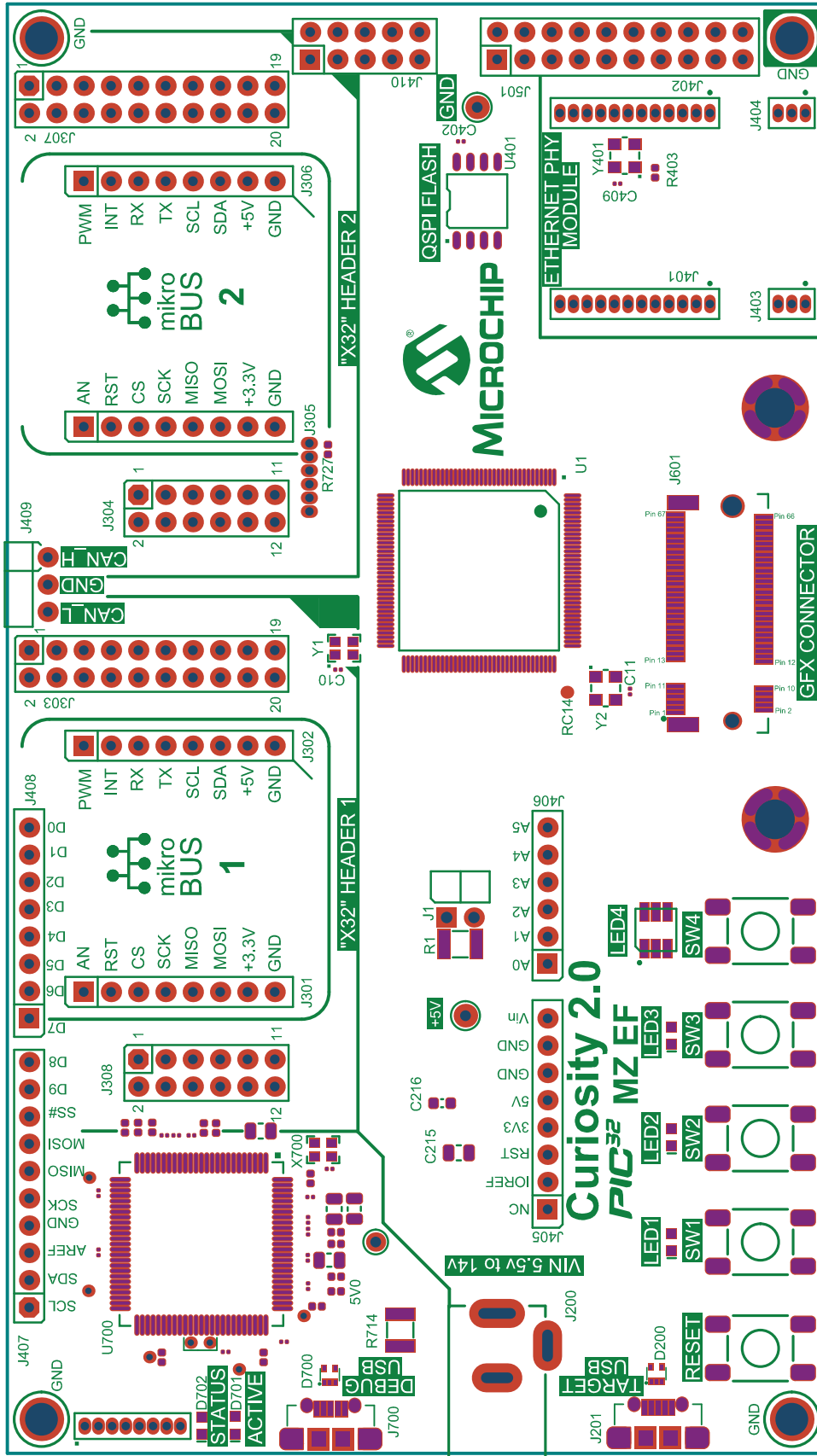

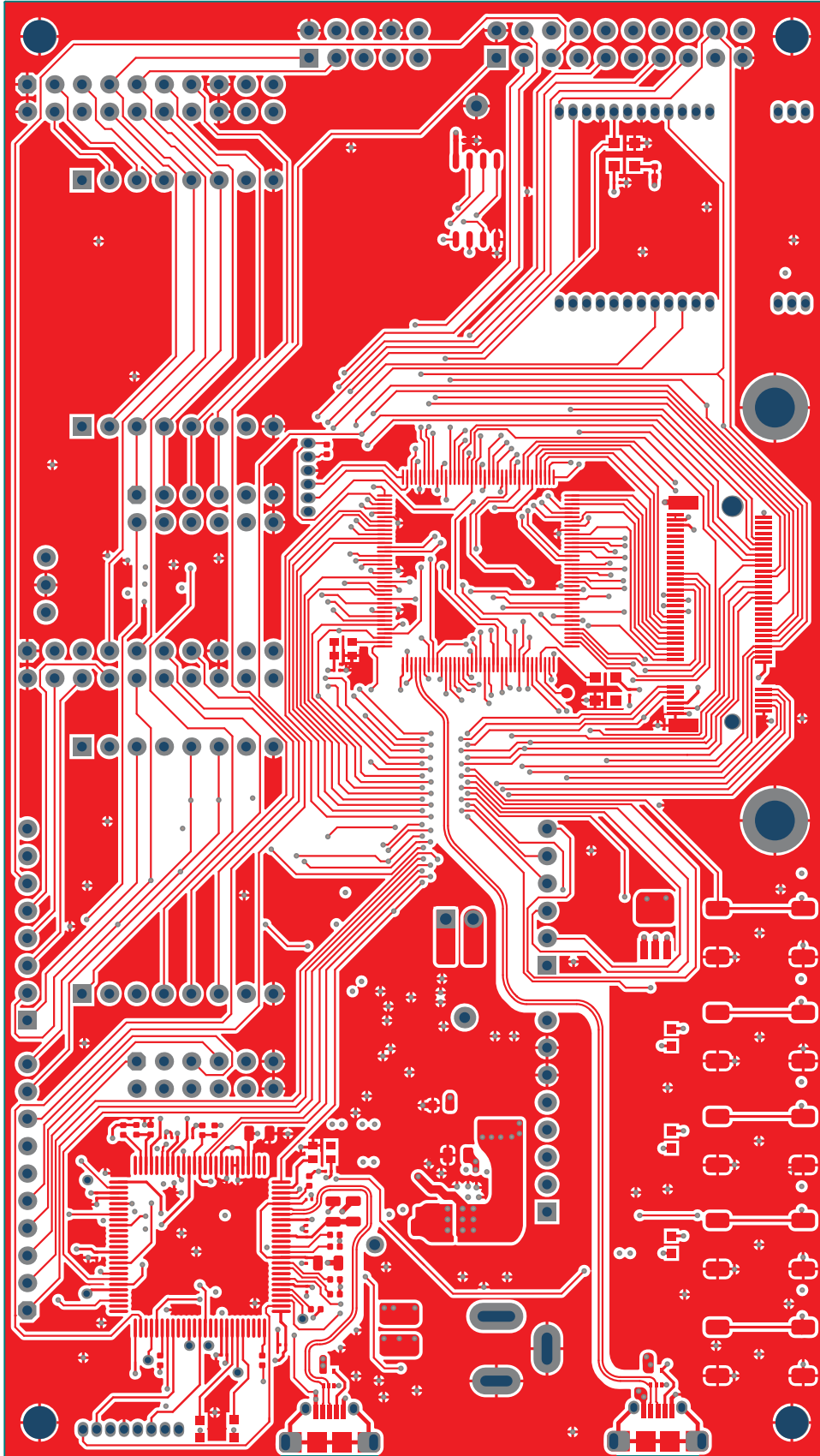

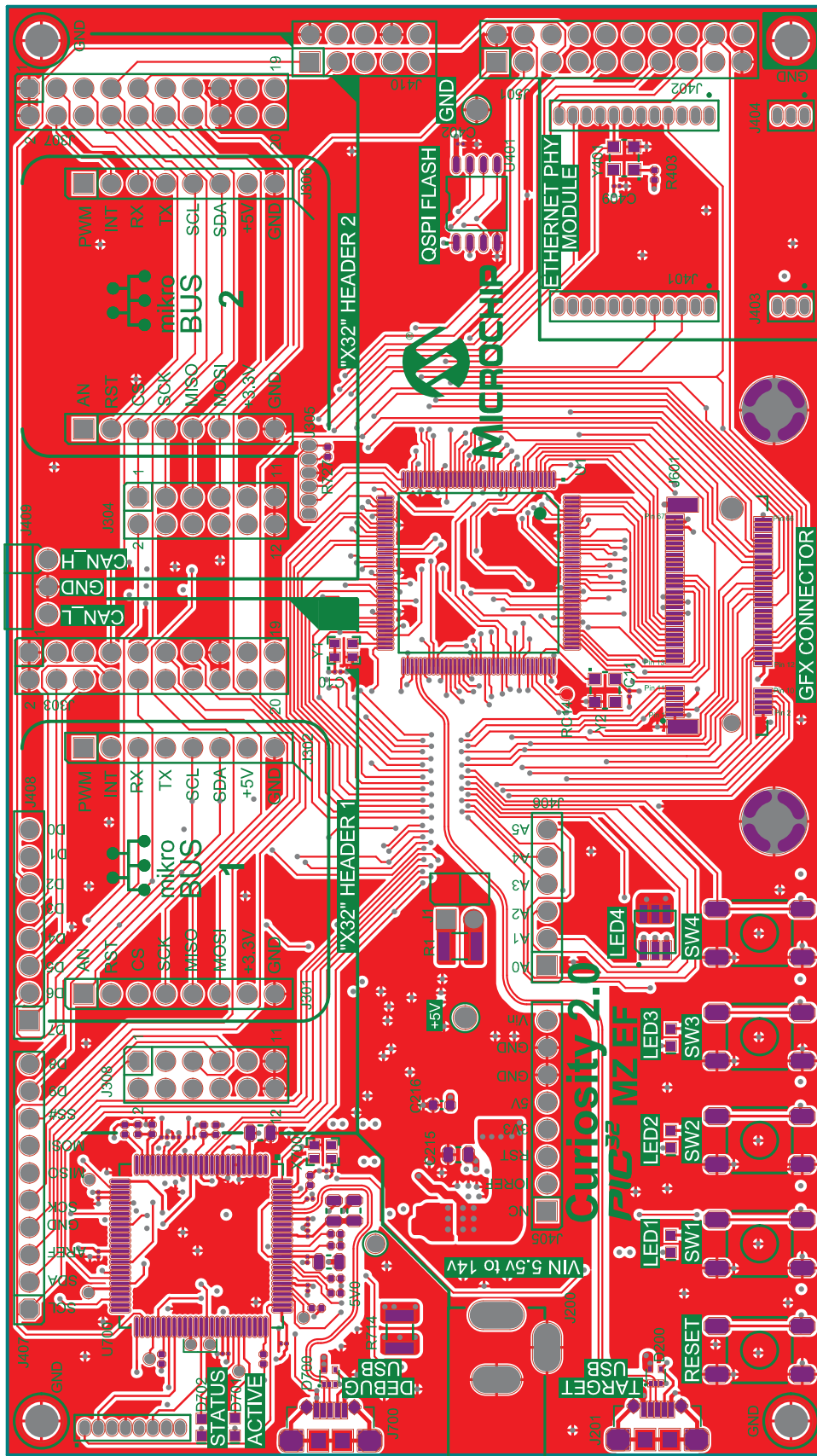

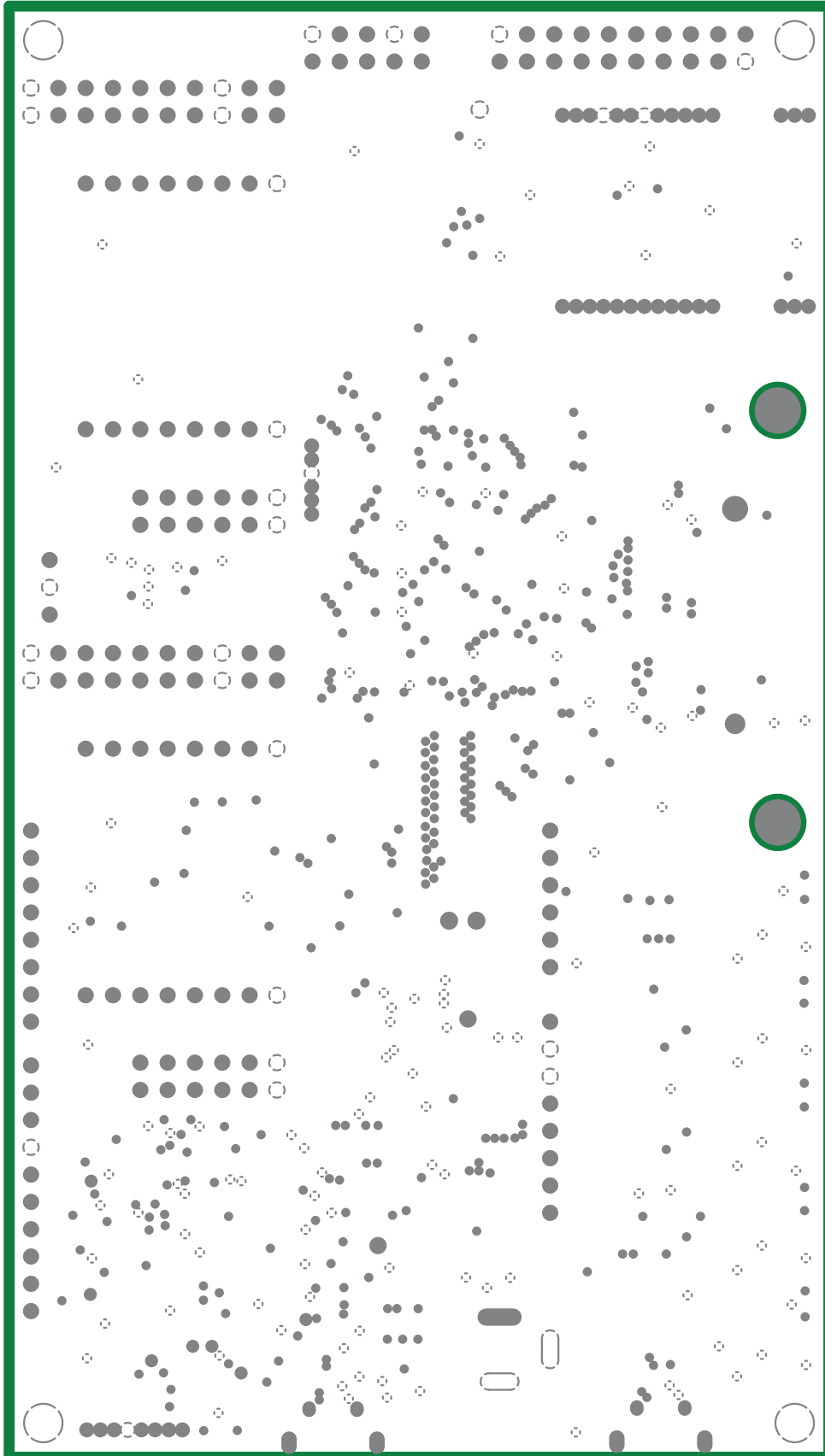

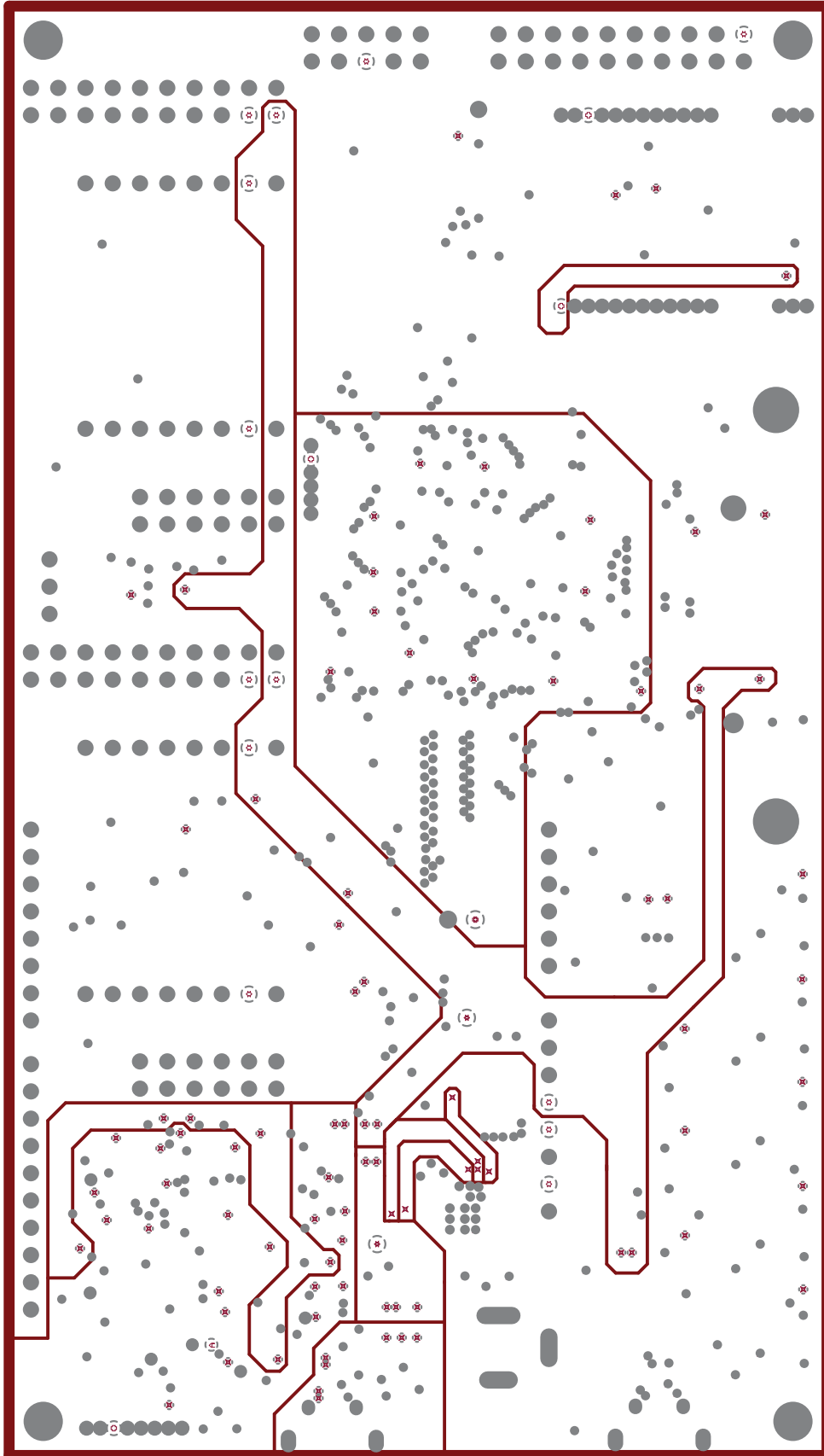

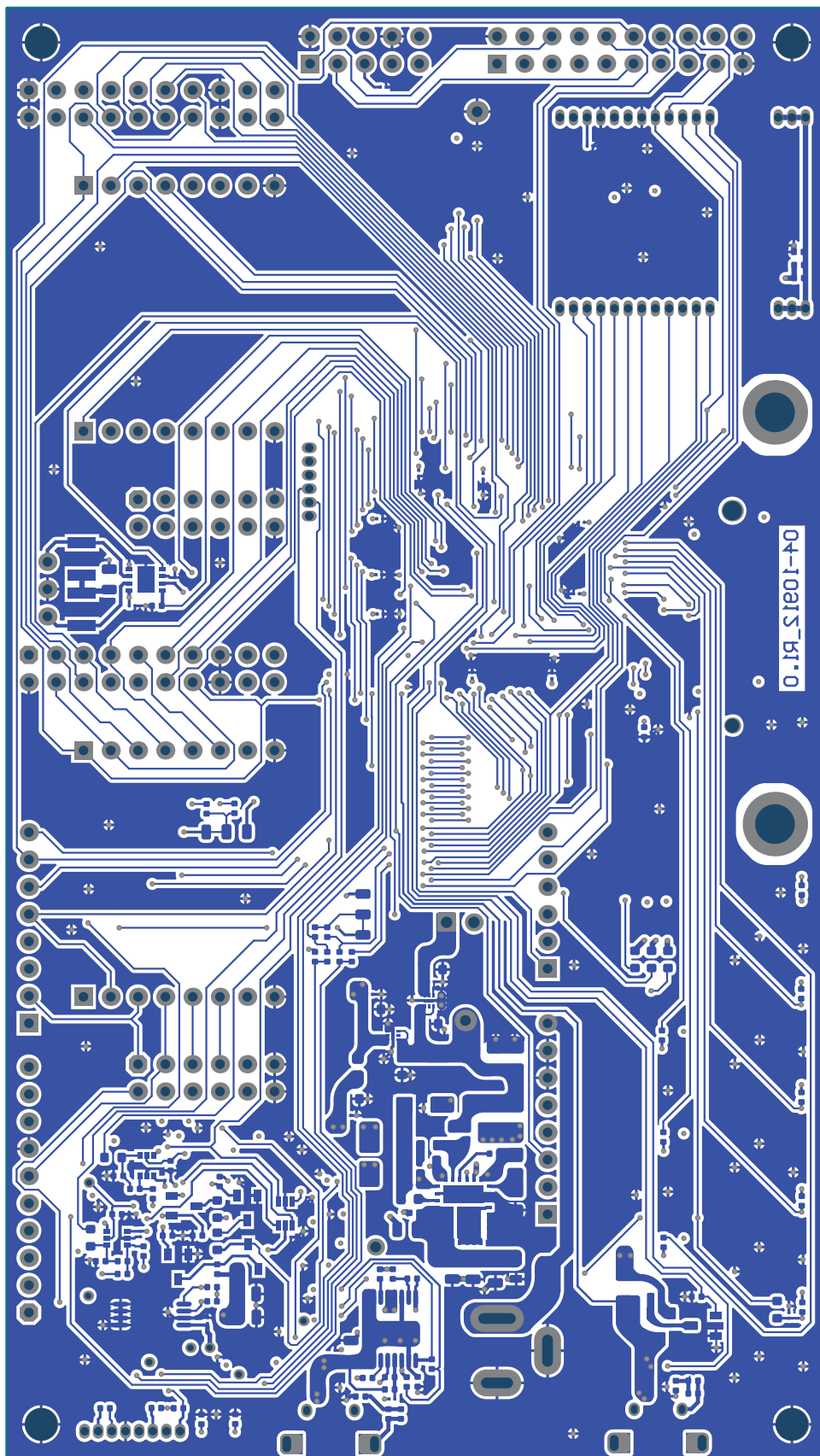

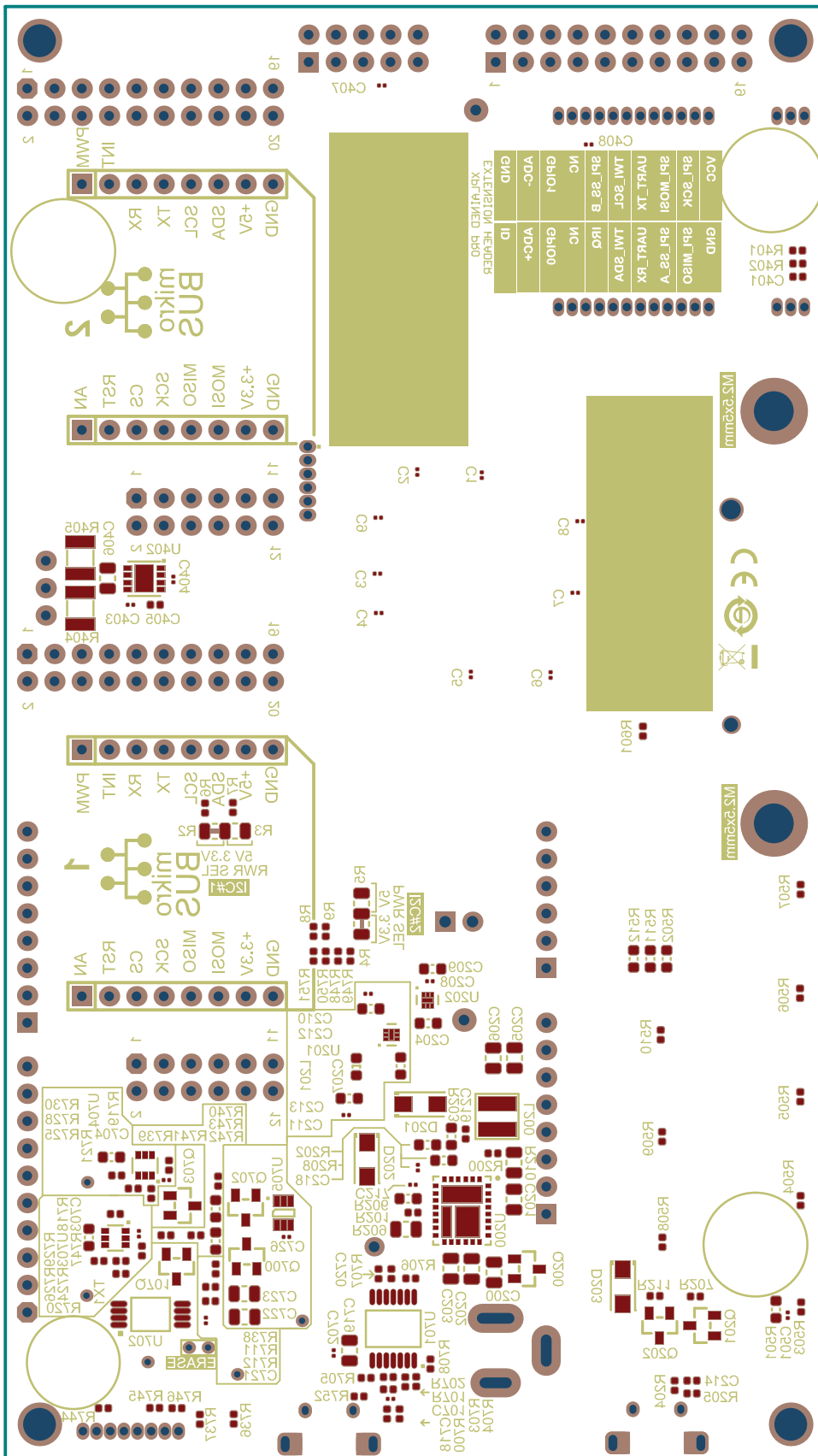

2.2 Bill of Materials

Quantity	Designator	Description
42	C1, C2, C3, C4, C5, C6, C7, C8, C9, C10, C11, C208, C210, C211, C217, C218, C402, C403, C404, C407, C408, C409, C501, C701, C702, C703, C704, C705, C706, C707, C708, C709, C710, C711, C712, C713, C714, C715, C716, C717, C721, C726	CAP CER 0.1µF 16V 10% X5R SMD 0201
1	C200	CAP CER 22µF 25V 20% X5R SMD 0805
1	C201	CAP CER 2.2µF 16V 10% X7R SMD 0805
5	C202, C203, C406, C724, C725	CAP CER 4.7µF 25V 10% X5R SMD 0805
6	C204, C207, C209, C212, C213, C216	CAP CER 1µF 16V 10% X7R SMD 0603
2	C205, C206	CAP CER 47µF 10V 20% X5R 0805
2	C219, C401	CAP CER 4700pF 50V 10% X7R SMD 0402
1	C215	CAP CER 0.1µF 25V 10% X7R SMD 0805
1	C405	CAP CER 15pF 50V 5% NP0 SMD 0402
3	C719, C722, C723	CAP CER 10µF 25V 10% X5R SMD 0805
1	C720	CAP CER 0.022µF 16V 10% X7R SMD 0402
2	D200, D700	DIO TVS ARRAY TPD3E001DRLR 11V 90W SMD SOT-553
3	D201, D202, D203	DIO SCKY MBR230LSFT1G 430mV 2A 30V SMD SOD-123FL
2	D701, LED2	DIO LED GREEN 2V 30mA 35mcd Clear SMD 0603
2	D702, LED3	DIO LED YELLOW 2.1V 20mA 6mcd Clear SMD 0603
1	J200	CON POWER 2.1mm 5.5mm Switch Slotted TH R/A
2	J201, J700	CONN RCPT USB MICRO AB SMD
4	J301, J302, J305, J306	CON HDR-2.54 Female 1x8 Tin TH VERT
2	J303, J307	CON HDR 2.54 MALE 2x10 3u" GOLD IN CONTACT AREA MATTE TIN ON TAIL 5.84MH TH VERT
2	J304, J308	CON HDR-2.54 Male 2x6 Gold 5.84MH TH VERT
2	J401, J402	CON STRIP-1.27 Female 1x12 Gold TH VERT
2	J403, J404	CON STRIP-1.27 Female 1x3 Gold TH VERT
1	J409	CON HDR-2.54 Male 1x3 Tin 6.2MH TH R/A
1	J501	CON HDR-2.54 Male 2x10 Gold 5.84MH TH R/A
1	J601	CONN EDGE DUAL FEMALE 67POS 0.5mm SMD R/A
1	L200	INDUCTOR 2.2µH 5.5A 20% SMD L4W4H2.1
1	L201	FERRITE 470R@100MHz 1A SMD 0603
2	L700, L701	FERRITE 2A 600R SMD 0805
1	LED1	DIO LED RED 1.8V 40mA 10mcd Clear SMD 0603
1	LED4	DIO LED TRI RED, GREEN, BLUE 2V, 3.2V, 3.2V 20mA, 20mA, 20mA SMD 6-PLCC
2	MH601, MH602	MECH RND STNDF M2.5X0.45 STEEL H2.5
5	nMCLR, SW1, SW2, SW3, SW4	SWITCH TACT SPST 24V 50mA KSR231GLFS SMD 6X3.5mm
3	Q200, Q202, Q700	TRANS FET P-CH IRLML6402 -20V -3.7A 1.3W SOT-23-3
1	R1	RES TKF 0R 1/3W SMD 1210
4	R6, R7, R8, R9	RES TKF 1.8k 1% 1/10W SMD 0402
13	R200, R201, R403, R503, R504, R505, R506, R507, R601, R703, R704, R708, R727	RES TKF 10k 1% 1/10W SMD 0402

.....continued

Quantity	Designator	Description
1	R202	RES TKF 19.6k 1% 1/10W SMD 0603
1	R203	RES TKF 2.49k 1% 1/10W SMD 0603
6	R204, R401, R713, R749, R751, R752	RES TKF 0R 1/16W SMD 0402
3	R205, R402, R700	RES TKF 1M 1% 1/10W SMD 0402
2	R209, R210	RES TKF 2.2R 1% 1/8W SMD 0805 AEC-Q200
5	R207, R211, R744, R745, R746	RES TKF 100k 1% 1/10W SMD 0402
11	R208	RES TKF 475R 1% 1/10W SMD 0603
1	R214	RES TKF 1.2R 1% 1/10W SMD 0603
2	R404, R405	RES TKF 62R 1% 1/2W SMD 1210
2	R501, R502	RES TKF 1k 1% 1/10W SMD 0603
10	R508, R509, R510, R720, R721, R722, R723, R736, R737, R747	RES TKF 330R 1% 1/16W SMD 0402
2	R511, R512	RES TKF 510R 1% 1/10W SMD 0603
1	R701	RES TKF 95.3k 1% 1/16W SMD 0402
2	R702, R717	RES TKF 5.62k 1% 1/16W SMD 0402
1	R705	RES TKF 470R 1% 1/16W MF 0402
1	R706	RES TKF 442k 1% 1/16W SMD 0402
1	R707	RES TKF 24.3k 1% 1/16W SMD 0402
2	R709, R715	RES TKF 31.6k 1% 1/10W SMD 0402
2	R710, R716	RES TKF 47k 5% 1/10W SMD 0402
9	R711, R712, R726, R728, R735, R738, R739, R740, R741	RES TKF 4.7k 1% 1/16W SMD 0402
2	R718, R719	RES TKF 3.3k 5% 1/10W SMD 0402
2	R729, R730	RES TKF 22 OHM 1% 1/10W SMD 0603
2	R742, R743	RES TKF 100R 5% 1/10W SMD 0603
2	U703, U704	IC TRANSCEIVER 74LVC1T45GW Single Bit Voltage Translator SOT-363
1	U705	IC SWITCH SPDT 74LVC1G3157 SC-70-6
4	Q701, Q702, Q703, Q201	MCHP ANALOG MOSFET N-CH TN2106 60V 280mA 360mW 2.5R SOT23-3
1	U1	MCHP MCU 32-BIT 2MB 512kB PIC32MZ2048EFH144-I/PH TQFP-144
1	U200	MCHP BUCK REGULATOR 12V 6A MIC24052 QFN-28
2	U201, U202	MCHP ANALOG LDO 3.3V MIC5528-3.3YMT-TR 6-TDFN
1	U401	MCHP MEMORY SERIAL FLASH 64M 104MHz SOI8
1	U402	MCHP INTERFACE CAN ATA6563-GBQW1 VDFN-8
1	U700	MCHP MCU 32-BIT 300MHz 2MB 384kB ATSAME70N21B-ANT LQFP-100
1	U701	MCHP ANALOG POWER SWITCH 5.5V 3A MIC2042-1YTS TSSOP-14
1	U702	MCHP MEMORY SERIAL EEPROM 256k I2C 24LC256-E/ST TSSOP-8
2	X700, Y1	MCHP CLOCK OSCILLATOR SINGLE 12.000MHZ DSC6011J11A-012.0000 VLGA
1	Y2	MCHP CLOCK OSCILLATOR SINGLE 32.768Hz DSC6083CE2A-032K768 SMD DFN-4
1	Y401	MCHP CLOCK OSCILLATOR 50MHz DSC1001CI2-050.0000T DFN-4
4	PAD1, PAD2, PAD3, PAD4	MECH HW RUBBER PAD CYLINDRICAL D9.53H5.97
DNP	J701	CON HDR-1.27 Female 1x8 TH VERT
DNP	J1	CON HDR-2.54 Male 1X2 Gold 6mm MH TH R/A

.....continued

Quantity	Designator	Description
DNP	J405, J408	CON HDR-2.54 Female 1x8 Tin TH VERT
DNP	J406	CON HDR-2.54 Female 1x6 Gold TH
DNP	J407	CON HDR-2.54 Female 1x10 Gold TH VERT
DNP	J410	CON HDR-2.54 Female 2x5 GOLD TH R/A
DNP	R724, R725, R748, R750	RES TKF 0R 1/16W SMD 0402
DNP	C214, C718	CAP CER 4700pF 50V 10% X7R SMD 0402
DNP	GND	MISC, TEST POINT MULTI PURPOSE MINI BLK
DNP	+5V	MISC, TEST POINT MULTI PURPOSE MINI RED
DNP	J702	CON HDR-1.27 Female 1x6 Gold TH VERT
DNP	R2, R3, R4, R5	RES TKF 0R 1/16W SMD 0805
DNP	R731, R732, R733, R734	RES TKF 4.7k 1% 1/16W SMD 0402
DNP	DAT_EN, ERASE, MH1, MH2, MH3, MH4, RX1, TP1, TP2, TP3V3, TX1, 5V0	Non-populated Test Points

2.3 Board Dimensions

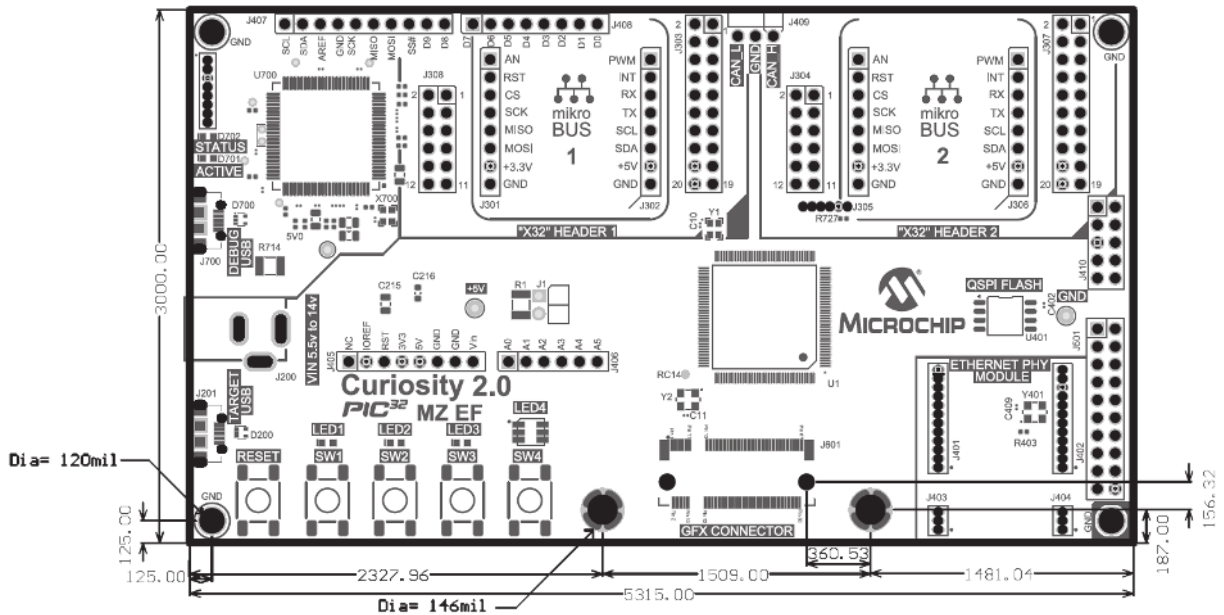

The Microchip Web Site

Microchip provides online support via our web site at <http://www.microchip.com/>. This web site is used as a means to make files and information easily available to customers. Accessible by using your favorite Internet browser, the web site contains the following information:

- **Product Support** – Data sheets and errata, application notes and sample programs, design resources, user's guides and hardware support documents, latest software releases and archived software
- **General Technical Support** – Frequently Asked Questions (FAQ), technical support requests, online discussion groups, Microchip consultant program member listing
- **Business of Microchip** – Product selector and ordering guides, latest Microchip press releases, listing of seminars and events, listings of Microchip sales offices, distributors and factory representatives

Customer Change Notification Service

Microchip's customer notification service helps keep customers current on Microchip products. Subscribers will receive e-mail notification whenever there are changes, updates, revisions or errata related to a specified product family or development tool of interest.

To register, access the Microchip web site at <http://www.microchip.com/>. Under "Support", click on "Customer Change Notification" and follow the registration instructions.

Customer Support

Users of Microchip products can receive assistance through several channels:

- Distributor or Representative
- Local Sales Office
- Field Application Engineer (FAE)
- Technical Support

Customers should contact their distributor, representative or Field Application Engineer (FAE) for support. Local sales offices are also available to help customers. A listing of sales offices and locations is included in the back of this document.

Technical support is available through the web site at: <http://www.microchip.com/support>

Microchip Devices Code Protection Feature

Note the following details of the code protection feature on Microchip devices:

- Microchip products meet the specification contained in their particular Microchip Data Sheet.
- Microchip believes that its family of products is one of the most secure families of its kind on the market today, when used in the intended manner and under normal conditions.
- There are dishonest and possibly illegal methods used to breach the code protection feature. All of these methods, to our knowledge, require using the Microchip products in a manner outside the operating specifications contained in Microchip's Data Sheets. Most likely, the person doing so is engaged in theft of intellectual property.
- Microchip is willing to work with the customer who is concerned about the integrity of their code.
- Neither Microchip nor any other semiconductor manufacturer can guarantee the security of their code. Code protection does not mean that we are guaranteeing the product as "unbreakable."

Code protection is constantly evolving. We at Microchip are committed to continuously improving the code protection features of our products. Attempts to break Microchip's code protection feature may be a violation of the Digital Millennium Copyright Act. If such acts allow unauthorized access to your software or other copyrighted work, you may have a right to sue for relief under that Act.

Legal Notice

Information contained in this publication regarding device applications and the like is provided only for your convenience and may be superseded by updates. It is your responsibility to ensure that your application meets with your specifications. MICROCHIP MAKES NO REPRESENTATIONS OR WARRANTIES OF ANY KIND WHETHER EXPRESS OR IMPLIED, WRITTEN OR ORAL, STATUTORY OR OTHERWISE, RELATED TO THE INFORMATION, INCLUDING BUT NOT LIMITED TO ITS CONDITION, QUALITY, PERFORMANCE, MERCHANTABILITY OR FITNESS FOR PURPOSE. Microchip disclaims all liability arising from this information and its use. Use of Microchip devices in life support and/or safety applications is entirely at the buyer's risk, and the buyer agrees to defend, indemnify and hold harmless Microchip from any and all damages, claims, suits, or expenses resulting from such use. No licenses are conveyed, implicitly or otherwise, under any Microchip intellectual property rights unless otherwise stated.

Trademarks

The Microchip name and logo, the Microchip logo, AnyRate, AVR, AVR logo, AVR Freaks, BitCloud, chipKIT, chipKIT logo, CryptoMemory, CryptoRF, dsPIC, FlashFlex, flexPWR, Heldo, JukeBlox, KeeLoq, Kleer, LANCheck, LINK MD, maXStylus, maXTouch, MediaLB, megaAVR, MOST, MOST logo, MPLAB, OptoLyzer, PIC, picoPower, PICSTART, PIC32 logo, Prochip Designer, QTouch, SAM-BA, SpyNIC, SST, SST Logo, SuperFlash, tinyAVR, UNI/O, and XMEGA are registered trademarks of Microchip Technology Incorporated in the U.S.A. and other countries.

ClockWorks, The Embedded Control Solutions Company, EtherSynch, Hyper Speed Control, HyperLight Load, IntelliMOS, mTouch, Precision Edge, and Quiet-Wire are registered trademarks of Microchip Technology Incorporated in the U.S.A.

Adjacent Key Suppression, AKS, Analog-for-the-Digital Age, Any Capacitor, AnyIn, AnyOut, BodyCom, CodeGuard, CryptoAuthentication, CryptoAutomotive, CryptoCompanion, CryptoController, dsPICDEM, dsPICDEM.net, Dynamic Average Matching, DAM, ECAN, EtherGREEN, In-Circuit Serial Programming, ICSP, INICnet, Inter-Chip Connectivity, JitterBlocker, KleerNet, KleerNet logo, memBrain, Mindi, MiWi, motorBench, MPASM, MPF, MPLAB Certified logo, MPLIB, MPLINK, MultiTRAK, NetDetach, Omniscient Code Generation, PICDEM, PICDEM.net, PICKit, PICtail, PowerSmart, PureSilicon, QMatrix, REAL ICE, Ripple Blocker, SAM-ICE, Serial Quad I/O, SMART-I.S., SQI, SuperSwitcher, SuperSwitcher II, Total Endurance, TSHARC, USBCheck, VariSense, ViewSpan, WiperLock, Wireless DNA, and ZENA are trademarks of Microchip Technology Incorporated in the U.S.A. and other countries.

SQTP is a service mark of Microchip Technology Incorporated in the U.S.A.

Silicon Storage Technology is a registered trademark of Microchip Technology Inc. in other countries.

GestIC is a registered trademark of Microchip Technology Germany II GmbH & Co. KG, a subsidiary of Microchip Technology Inc., in other countries.

All other trademarks mentioned herein are property of their respective companies.

© 2019, Microchip Technology Incorporated, Printed in the U.S.A., All Rights Reserved.

ISBN: 978-1-5224-4834-1

Quality Management System Certified by DNV

ISO/TS 16949

Microchip received ISO/TS-16949:2009 certification for its worldwide headquarters, design and wafer fabrication facilities in Chandler and Tempe, Arizona; Gresham, Oregon and design centers in California and India. The Company's quality system processes and procedures are for its PIC® MCUs and dsPIC® DSCs, KEELOQ® code hopping devices, Serial EEPROMs, microperipherals, nonvolatile memory and analog products. In addition, Microchip's quality system for the design and manufacture of development systems is ISO 9001:2000 certified.

Worldwide Sales and Service

AMERICAS	ASIA/PACIFIC	ASIA/PACIFIC	EUROPE
<p>Corporate Office 2355 West Chandler Blvd. Chandler, AZ 85224-6199 Tel: 480-792-7200 Fax: 480-792-7277 Technical Support: http://www.microchip.com/support Web Address: www.microchip.com</p> <p>Atlanta Duluth, GA Tel: 678-957-9614 Fax: 678-957-1455</p> <p>Austin, TX Tel: 512-257-3370</p> <p>Boston Westborough, MA Tel: 774-760-0087 Fax: 774-760-0088</p> <p>Chicago Itasca, IL Tel: 630-285-0071 Fax: 630-285-0075</p> <p>Dallas Addison, TX Tel: 972-818-7423 Fax: 972-818-2924</p> <p>Detroit Novi, MI Tel: 248-848-4000</p> <p>Houston, TX Tel: 281-894-5983</p> <p>Indianapolis Noblesville, IN Tel: 317-773-8323 Fax: 317-773-5453 Tel: 317-536-2380</p> <p>Los Angeles Mission Viejo, CA Tel: 949-462-9523 Fax: 949-462-9608 Tel: 951-273-7800</p> <p>Raleigh, NC Tel: 919-844-7510</p> <p>New York, NY Tel: 631-435-6000</p> <p>San Jose, CA Tel: 408-735-9110 Tel: 408-436-4270</p> <p>Canada - Toronto Tel: 905-695-1980 Fax: 905-695-2078</p>	<p>Australia - Sydney Tel: 61-2-9868-6733</p> <p>China - Beijing Tel: 86-10-8569-7000</p> <p>China - Chengdu Tel: 86-28-8665-5511</p> <p>China - Chongqing Tel: 86-23-8980-9588</p> <p>China - Dongguan Tel: 86-769-8702-9880</p> <p>China - Guangzhou Tel: 86-20-8755-8029</p> <p>China - Hangzhou Tel: 86-571-8792-8115</p> <p>China - Hong Kong SAR Tel: 852-2943-5100</p> <p>China - Nanjing Tel: 86-25-8473-2460</p> <p>China - Qingdao Tel: 86-532-8502-7355</p> <p>China - Shanghai Tel: 86-21-3326-8000</p> <p>China - Shenyang Tel: 86-24-2334-2829</p> <p>China - Shenzhen Tel: 86-755-8864-2200</p> <p>China - Suzhou Tel: 86-186-6233-1526</p> <p>China - Wuhan Tel: 86-27-5980-5300</p> <p>China - Xian Tel: 86-29-8833-7252</p> <p>China - Xiamen Tel: 86-592-2388138</p> <p>China - Zhuhai Tel: 86-756-3210040</p>	<p>India - Bangalore Tel: 91-80-3090-4444</p> <p>India - New Delhi Tel: 91-11-4160-8631</p> <p>India - Pune Tel: 91-20-4121-0141</p> <p>Japan - Osaka Tel: 81-6-6152-7160</p> <p>Japan - Tokyo Tel: 81-3-6880-3770</p> <p>Korea - Daegu Tel: 82-53-744-4301</p> <p>Korea - Seoul Tel: 82-2-554-7200</p> <p>Malaysia - Kuala Lumpur Tel: 60-3-7651-7906</p> <p>Malaysia - Penang Tel: 60-4-227-8870</p> <p>Philippines - Manila Tel: 63-2-634-9065</p> <p>Singapore Tel: 65-6334-8870</p> <p>Taiwan - Hsin Chu Tel: 886-3-577-8366</p> <p>Taiwan - Kaohsiung Tel: 886-7-213-7830</p> <p>Taiwan - Taipei Tel: 886-2-2508-8600</p> <p>Thailand - Bangkok Tel: 66-2-694-1351</p> <p>Vietnam - Ho Chi Minh Tel: 84-28-5448-2100</p>	<p>Austria - Wels Tel: 43-7242-2244-39 Fax: 43-7242-2244-393</p> <p>Denmark - Copenhagen Tel: 45-4450-2828 Fax: 45-4485-2829</p> <p>Finland - Espoo Tel: 358-9-4520-820</p> <p>France - Paris Tel: 33-1-69-53-63-20 Fax: 33-1-69-30-90-79</p> <p>Germany - Garching Tel: 49-8931-9700</p> <p>Germany - Haan Tel: 49-2129-3766400</p> <p>Germany - Heilbronn Tel: 49-7131-67-3636</p> <p>Germany - Karlsruhe Tel: 49-721-625370</p> <p>Germany - Munich Tel: 49-89-627-144-0 Fax: 49-89-627-144-44</p> <p>Germany - Rosenheim Tel: 49-8031-354-560</p> <p>Israel - Ra'anana Tel: 972-9-744-7705</p> <p>Italy - Milan Tel: 39-0331-742611 Fax: 39-0331-466781</p> <p>Italy - Padova Tel: 39-049-7625286</p> <p>Netherlands - Drunen Tel: 31-416-690399 Fax: 31-416-690340</p> <p>Norway - Trondheim Tel: 47-72884388</p> <p>Poland - Warsaw Tel: 48-22-3325737</p> <p>Romania - Bucharest Tel: 40-21-407-87-50</p> <p>Spain - Madrid Tel: 34-91-708-08-90 Fax: 34-91-708-08-91</p> <p>Sweden - Gothenberg Tel: 46-31-704-60-40</p> <p>Sweden - Stockholm Tel: 46-8-5090-4654</p> <p>UK - Wokingham Tel: 44-118-921-5800 Fax: 44-118-921-5820</p>