



## A Tallysman *Accutenna*™ TW3752 High Gain / High Rejection GPS + GLONASS + Galileo + BeiDou Timing Antenna

The TW3752 is a high-gain GPS + GLONASS + Galileo + BeiDou antenna specifically designed for timing applications in high density cell / telecommunications tower applications where high levels of near-out-of-band interfering signals can be expected.

The TW3752 covers the GPS L1, GLONASS G1, Galileo E1, BeiDou B1, and SBAS (WAAS, EGNOS & MSAS) frequency band and employs Tallysman's unique *Accutenna*™ technology to provide excellent cross polarization rejection and greatly enhanced multipath rejection.

The TW3752 features triple SAW filters including a tight, low loss pre-filter to protect against saturation by high level sub-harmonic and L-Band signals. This antenna also features a 50dB LNA gain to handle the long cable runs sometimes associated with telecommunications towers.

The TW3752 housing has a permanent mount, IP67 compliant metal base, and an extended temperature range plastic radome, and is specifically designed to withstand the most challenging environmental conditions.

Two options for pole mounting are available an L-bracket (P/N#23-0040-0) or a pipe mount (P/N#23-0065-0).

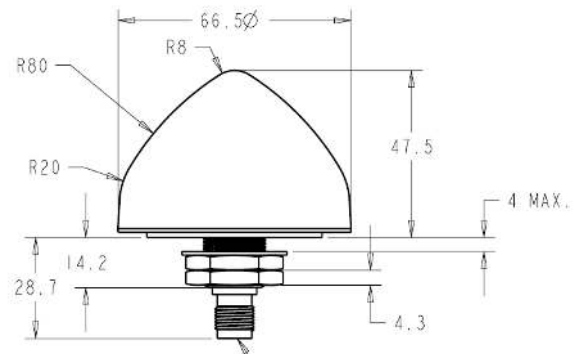

### Applications

- Timing systems
- Long cable runs

### Features

- Dual Feed Patch Antenna
- Low Loss SAW Pre-Filter
- Great axial ratio: 1 dB typ.
- Low noise LNA: < 2.5 dB typ.
- Triple High rejection SAW filter
- High gain LNA: 50 dB typ.
- Low current: 30 mA typ.
- Wide voltage input range: 2.7 to 26 VDC
- IP67 weather proof housing

### Benefits

- Great out of band rejection
- Excellent multipath rejection
- Excellent circular polarisation
- Excellent signal to noise ratio
- Increased system accuracy
- Ideal for harsh environments
- RoHS compliant



## TW3752 High Gain / High Rejection GPS + GLONASS + Galileo + BeiDou Timing Antenna

### Specifications

---

#### Antenna

Architecture	Dual, Quadrature Feeds
1 dB Bandwidth	47 MHz
Antenna Gain (with 100mm ground plane)	4.5 dBic @ 90°
Axial Ratio (over full bandwidth)	<1 dB @zenith typ., 3 dB max.

#### Electrical

Filtered LNA Frequency Bandwidth	1559 to 1606 MHz
Polarization	RHCP
LNA Gain	50 dB min., across full bandwidth
Gain flatness	+/- 2dB, 1559 to 1606 MHz
Out-of-Band Rejection	<1525 MHz >60 dB >1650 MHz >60 dB
VSWR (at LNA output)	<1.5:1
Noise Figure	2.5 dB typ
Supply Voltage Range (over coaxial cable)	2.7 to 26 VDC nominal
Supply Current	30 mA typ., 35mA max
ESD Circuit Protection	15 KV air discharge

#### Mechanicals & Environmental

Mechanical Size	66.5 mm dia. x 21 mm H
Operating Temp. Range	-40 to +85 °C
Enclosure	Radome: EXL9330, Base: Zamak White Metal (M18x1thread)
Weight	150 g
Attachment Method	Permanent 3/4" (19mm) through hole mount
Environmental	IP67 and RoHS compliant
Shock	Vertical axis: 50 G, other axes: 30 G
Vibration	3 axis, sweep = 15 min, 10 to 200 Hz sweep: 3 G

### Ordering Information

---

TW3752 – High Gain / High Rejection 4 Constellation Timing Antenna                      33-3752-xx-yy-zzzz

Where xx = connector type, yy = shape and colour of radome, and zzzz = cable length in mm (where applicable)

Please refer to the Ordering Guide (<http://www.tallysman.com/wp-content/uploads/Current-Ordering-Guide.pdf>) for the current and complete list of available radomes and connectors.

### Tallysman Wireless Inc

106 Schneider Road, Unit 3  
Ottawa ON K2K 1Y2 Canada                      Tel 613 591 3131                      Fax 613 591 3121  
[sales@tallysman.com](mailto:sales@tallysman.com)

The information provided herein is intended as a guide only and is subject to change without notice. This document is not to be regarded as a guarantee of performance. Tallysman Wireless Inc. hereby disclaims any or all warranties and liabilities of any kind. © 2015 Tallysman Wireless Inc. All rights reserved. Rev 1.0