

### **DESCRIPTION**

The EVKT-KNOB is an evaluation kit for the MagAlpha magnetic position sensor family. The EVKT-KNOB allows users to run and test the MagAlpha sensor quickly. It is delivered assembled with a knob and magnet. The sensor is mounted in an end-of-shaft configuration.

The EVKT-KNOB is compatible with the MACOM kit, offering seamless connection and operation of the MagAlpha and allowing users to evaluate MagAlpha functionalities and performances, such as noise level, refresh rate, power-up time, magnetic field dependence, and more.

### **FEATURES**

- Ready-to-Use Knob with End-of-Shaft Magnet
- Extra Spacers
- Compatible with MagAlpha Communication Interface Kit (EVKT-MACOM)

### **APPLICATIONS**

- Knobs
- Potentiometer Replacements
- Dials
- Appliances
- Consumer Goods

All MPS parts are lead-free, halogen-free, and adhere to the RoHS directive. For MPS green status, please visit the MPS website under Quality Assurance. "MPS", the MPS logo, and "Simple, Easy Solutions" are registered trademarks of Monolithic Power Systems, Inc. or its subsidiaries.

### **OVERVIEW**

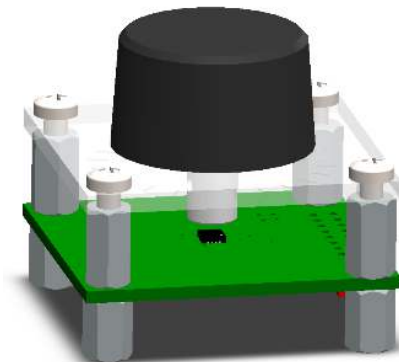

**Figure 1: EVKT-KNOB**

### Board Type

Different board types are available, and each has a different schematic and layout design. Which board type should be used is determined by the selected sensor part number.

**Table 1: Board Type**

Kit Part Number	Board Part Number	MPS Chip Part Number
EVKT800-KNOB	EVMA800-Q-01A	MA800
EVKT820-KNOB	EVMA820-Q-01A	MA820
EVKT850-KNOB	EVMA850-Q-01A	MA850

### EVKT-KNOB Content

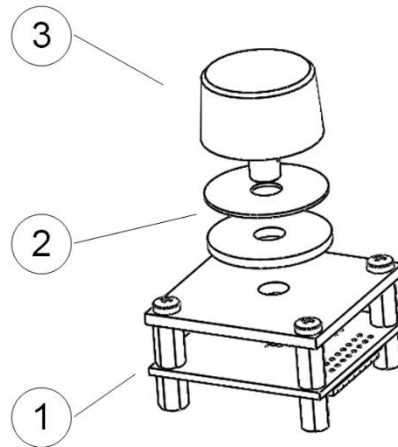

**Figure 2: Kit Contents**

1. EVMA board with MagAlpha mounted
2. 0.7mm and 2.0mm spacers
3. Knob with magnet
4. Extra cylinder magnet, NdFeB N35 D = 5mm, H = 2.5mm (not shown)

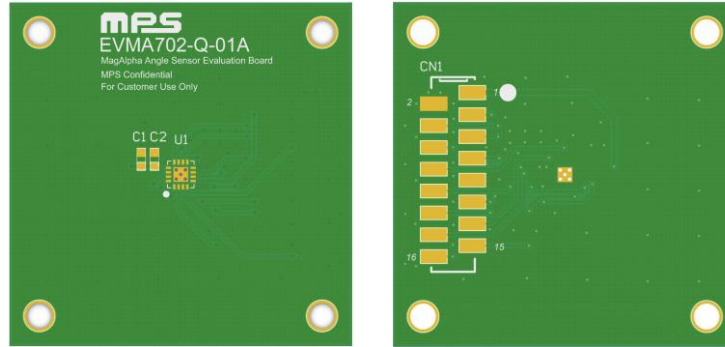

Figure 2: Board Overview Type 2

Schematic

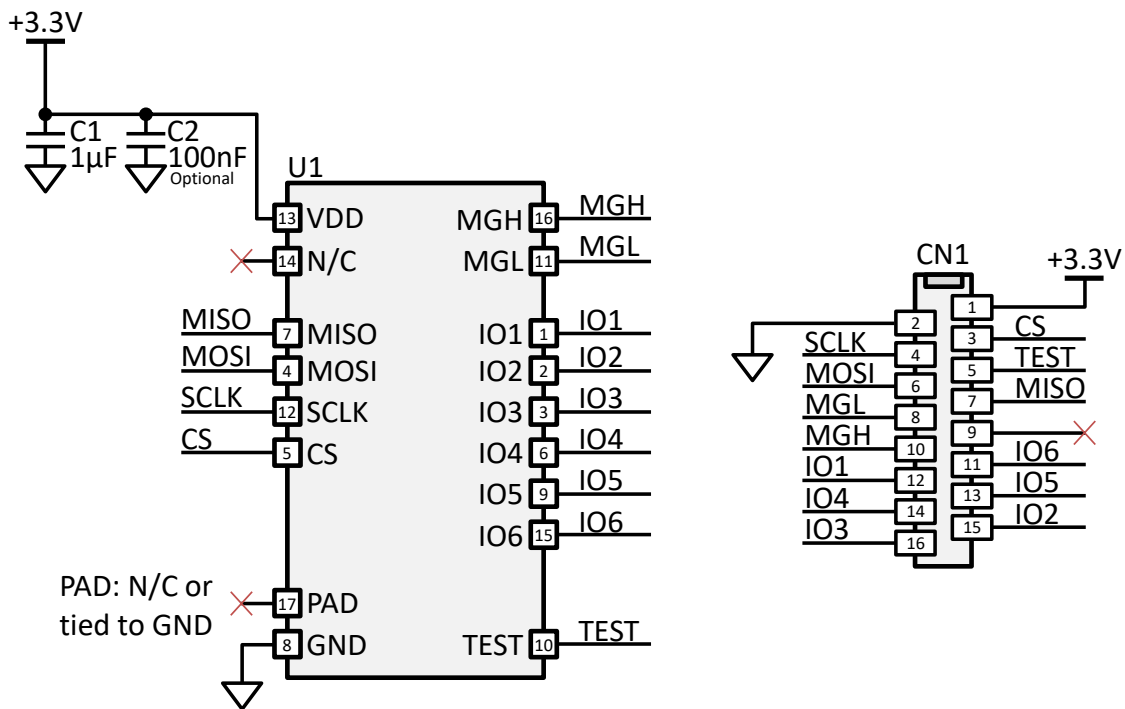

Figure 3: Schematic Type 2

Bill of Materials

Table 2: Bill of Materials Type 2

Quantity	Designator	Description	Value	Manufacturer	Manufacturer PN
1	C1	Ceramic capacitor, 16V, X7R, 0603	1µF	Murata	GRM188R71C105MA12D
1	C2 (not populated)	Ceramic capacitor, 25V, X7R, 0603	100nF	Murata	GRM188R71E104MA01D
1	U1	MagAlpha magnetic position sensor	MAxxx	MPS	
1	CN1	16 position receptacle connector 0.100" (2.54mm) surface-mount tin		Würth Elektronik or TE Connectivity	690367281676 or 8-2178711-6

Assembly View

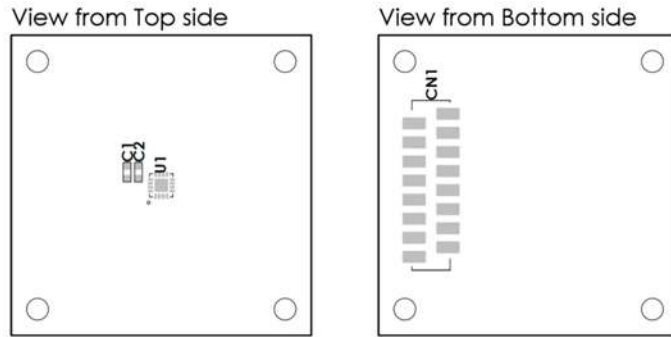

Figure 4: Assembly View Type 2

Mechanical Drawing

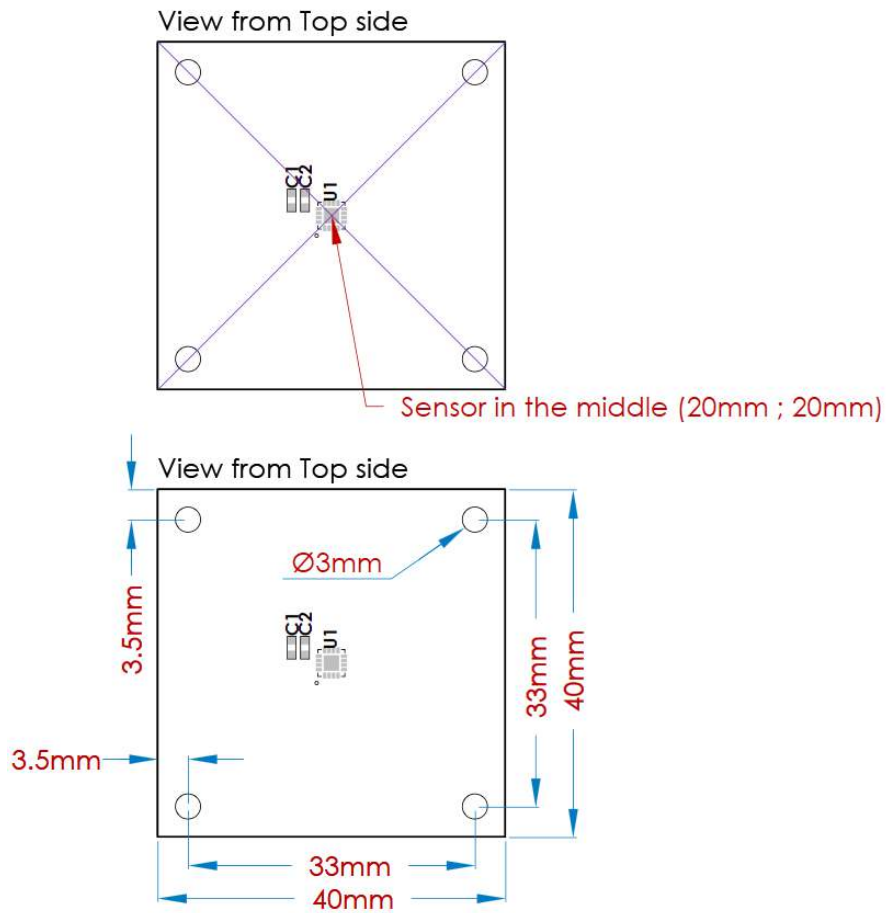
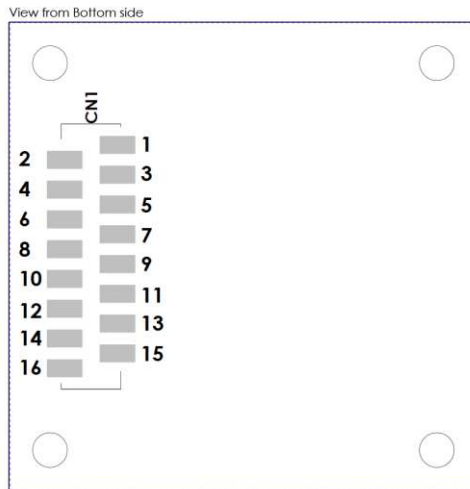

Figure 5: Mechanical Drawing Type 2

**Connector Pin Out**

**Figure 6: Connector Pin Out Type 2**
**Table 3: Connector Pin Mapping Type 2**

Pin	Name	Description
CN1.1	VDD	<b>3.3V supply.</b>
CN1.2	GND	<b>Ground.</b>
CN1.3	CS	<b>Chip select (serial).</b>
CN1.4	SCLK	<b>Clock (serial).</b>
CN1.5	TEST	<b>Test pin.</b>
CN1.6	MOSI	<b>Master out slave in (serial).</b>
CN1.7	MISO	<b>Master in slave out (serial).</b>
CN1.8	MGL <sup>(2)</sup>	<b>Magnetic level low (option).</b>
CN1.9		
CN1.10	MGH <sup>(2)</sup>	<b>Magnetic level high (option).</b>
CN1.11	IO6 <sup>(3)</sup>	<b>Pin 15 (IO).</b>
CN1.12	IO1 <sup>(3)</sup>	<b>Pin 1 (IO).</b>
CN1.13	IO5 <sup>(3)</sup>	<b>Pin 9 (IO).</b>
CN1.14	IO4 <sup>(3)</sup>	<b>Pin 6 (IO).</b>
CN1.15	IO2 <sup>(3)</sup>	<b>Pin 2 (IO).</b>
CN1.16	IO3 <sup>(3)</sup>	<b>Pin 3 (IO).</b>

**NOTES:**

- 1) The availability of this option depends of the chip part ID. Please refer to the part datasheet directly.
- 2) Please refer to the chip datasheet directly to know which feature is available on this pin.

## MAGNETIC FIELD

An NdFeB cylinder magnet is mounted at the end of the aluminum shaft.

**Table 4: Magnet Characteristics**

Material	NdFeB (N35 or N35H)
Remanence (Br)	1.2T
Diameter	5mm
Height	2.5mm
Magnetization	Diametrical

### How to Change the Mechanical Zero

Unscrew the knob with a 1/16-inch hex key (Allen wrench). Hold the shaft with a pin inserted in the 2mm diameter hole, and rotate the knob to the desired position. When tightening the screw, ensure that the key is fully inserted. Note that the zero position can also be adjusted through programming, as described in the MagAlpha datasheet.

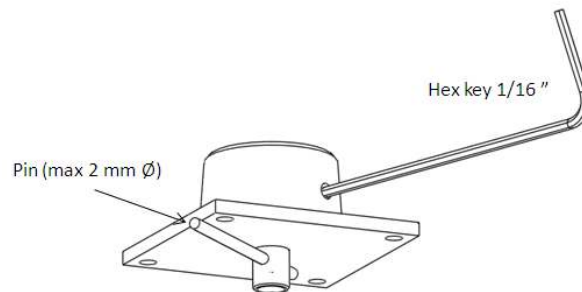

**Figure 7: Adjusting the Magnet Angular Position**

### How to Change the Magnetic Field Amplitude

The performance of the MagAlpha remains the same from 75mT to 150mT and higher (the MagAlpha has no maximum operating field). The critical region is the lower end of the specified range. Some parameters (e.g. noise, linearity) deteriorate gradually when the magnetic field becomes weak. The two spacers enclosed in this evaluation kit allow the sensor (the noise level in particular) to be tested at low magnetic fields.

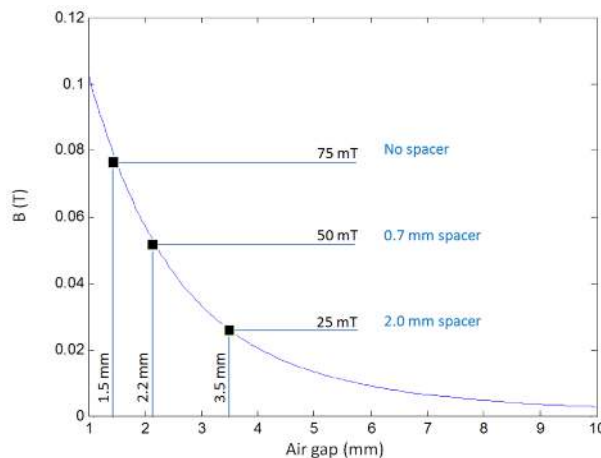
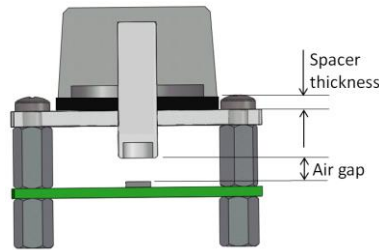

**Figure 8: Magnetic Field vs. Air Gap for the Supplied Magnet**

The EVMA nominal magnet sensor distance is 1.5mm, providing a magnetic field of 75mT. With the spacers, the field strength is reduced to 50mT or 25mT (see Table 5).

**Table 5: Setting of the Air Gap**

Spacer Thickness (mm)	Air Gap (mm)	Magnetic Field (mT)
None	1.5	75
0.7	2.2	50
2	3.5	25



**Figure 9: Air Gap Setting**

## MAGNET SUPPLIERS

The table below shows a non-exhaustive list of possible magnet suppliers. The magnetization direction must be chosen carefully given the fact that most magnets sold are axially magnetized, which is not a magnetization direction usually required in magnetic angle-sensing applications. Angle-sensing applications usually use diametrically magnetized magnets.

**Table 6: Magnet Suppliers**

Company	Website	Address
Maurer Magnetics AG	<a href="http://www.maurermagnetic.ch">www.maurermagnetic.ch</a>	Industriestrasse 8 8627 Grüningen Switzerland
Arnold Technologies AG	<a href="http://www.arnoldmagnetics.com">www.arnoldmagnetics.com</a>	Hübelacherstrasse 15 5242 Birr-Lupfig Switzerland
Bomatec AG	<a href="http://www.bomatec.com">www.bomatec.com</a>	Hofstrasse 1 8181 Höri Switzerland
Dexter Magnetic Technologies	<a href="http://www.dextermag.com">www.dextermag.com</a>	1050 Morse Avenue Elk Grove Village, IL 60007-5110 USA
JPMF	<a href="http://www.jpmp.com.cn">www.jpmp.com.cn</a>	8 LongWan Road Jiangmen City GuangDong Province China
Binicmagnet	<a href="http://www.binicmagnet.com">www.binicmagnet.com</a>	Unit 612 Yuanzhong Building No. 1905 Hongmei Road Shanghai P. R. China 200233
China Rare Earth Magnet	<a href="http://www.permanentmagnet.com">www.permanentmagnet.com</a>	Room 705, Tower A Century Holiday Plaza 9030 Shennan Road Nanshan District Shenzhen China
Goudsmit Magnetic Systems	<a href="http://www.goudsmit-magnetics.nl">www.goudsmit-magnetics.nl</a>	Petunialaan 19 5582 HA Waalre Netherlands

**Maurer Magnetic**

Maurer Magnetic has a selection of diametrically magnetized magnets well-suited for contactless rotary angle applications. Samples of the types mentioned below should always be available with no lead time.

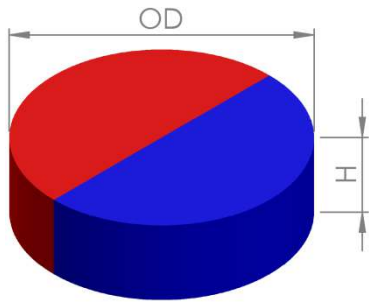

**Figure 10: Cylinder Magnet,  
Diametrically Magnetized**

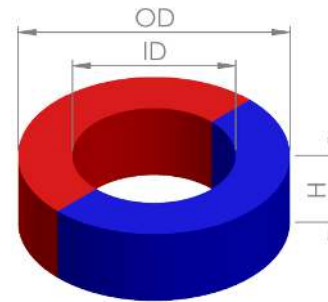

**Figure 11: Ring Magnet,  
Diametrically Magnetized**

**Table 7: Maurer Magnetic Diametrically Magnetized Magnets**

OD (mm)	ID (mm)	H (mm)	Material	Remanence (Br) (T)	Magnetization	Part Number
4.0	-	3.0	N35	1.2	Diametrical	M610403
4.0	-	3.0	Sm26/16-17	1.08	Diametrical	M410403
5.0	-	2.5	N35	1.2	Diametrical	M610502
5.0	-	2.5	Sm26/16-17	1.08	Diametrical	M410502
5.0	1.25	2.5	N35	1.2	Diametrical	M610512
5.0	1.25	2.5	Sm26/16-17	1.08	Diametrical	M410512
6.0	-	2.5	N35	1.2	Diametrical	M610602
6.0	-	2.5	Sm26/16-17	1.08	Diametrical	M410602
6.0	1.5	2.5	N35	1.2	Diametrical	M610612
6.0	1.5	2.5	Sm26/16-17	1.08	Diametrical	M410612
6.0	1.5	3.0	N35	1.2	Diametrical	M610613
6.0	1.5	3.0	Sm26/16-17	1.08	Diametrical	M410613
8.0	-	2.5	N35	1.2	Diametrical	M610802
8.0	-	2.5	Sm26/16-17	1.08	Diametrical	M410802

**NOTICE:** The information in this document is subject to change without notice. Please contact MPS for current specifications. Users should warrant and guarantee that third-party Intellectual Property rights are not infringed upon when integrating MPS products into any application. MPS will not assume any legal responsibility for any said applications.