

1 2 3 4 5 6

A  
B  
C  
D

view without cover

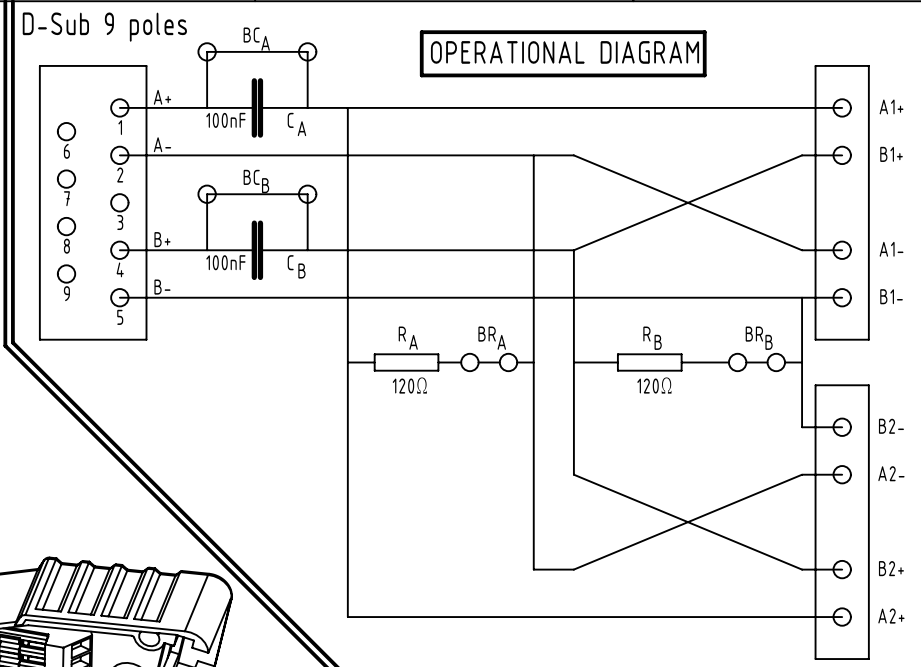
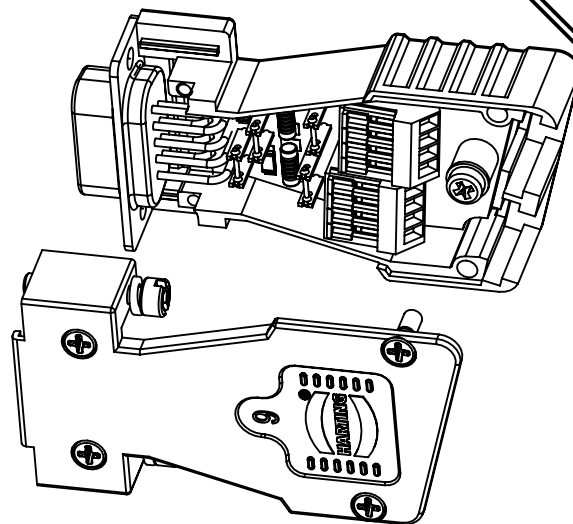
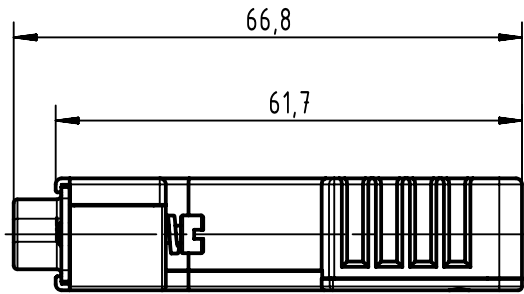
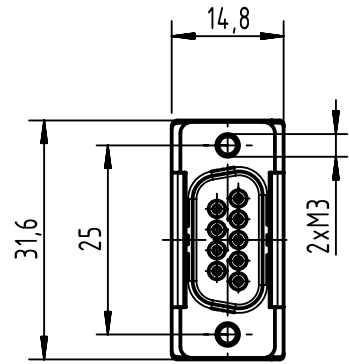
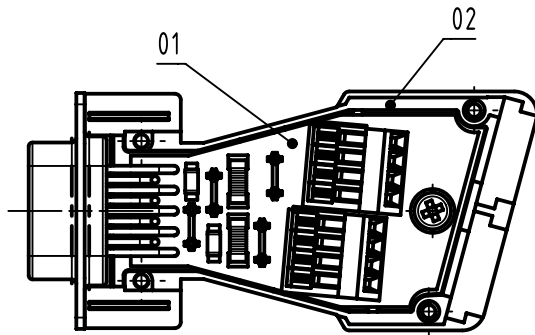

in set inclusive :

| Number | Description             |
|--------|-------------------------|
| 2      | Crimp flange 6,5-7,5    |
| 2      | Crimp ferrule 10,0-11,0 |
| 1      | blanking piece 9-37     |
| 1      | lable line A ,B         |
| 1      | PCBA                    |

|                                      |   |  |                      |                           |  |
|--------------------------------------|---|--|----------------------|---------------------------|--|
|                                      | All rights reserved<br>Department EL PD | All Dimensions in mm<br>Original Size DIN A4 | Scale<br>1:1         | Free size tol.            | Ref.   |
|                                      |   | Created by<br>ZHUANGJ                        | Inspected by<br>LUOK | Standardisation<br>ROEBEN | Date<br>2021-08-04                                       |
| Title<br>InduCom 9 MVB/WTB female M3 |   | Type<br>TB                                   |                      |                           | Doc-Key / ECM-Nr.<br>100075722/UGD/005/D<br>500000200533 |
| Part number<br>6663 009 5222 777     |   | Performance level<br>PL2                     |                      | Remark<br>Small batch     |  |
| Part number<br>6663 009 5222         |   | Performance level<br>PL2                     |                      | Remark<br>Standard batch  |  |
| Part number<br>6663 009 5222         |   | Performance level<br>PL2                     |                      | Remark<br>Standard batch  |  |
| HARTING<br>D-32339 Espelkamp         |   | Number<br>66630095222                        |                      | Rev.<br>D                 | Page<br>1/1  |