

System LED Drivers for Mobile Phones

7x17(Max.) Dot Matrix LED Display Driver



BD26503GUL

●Description

BD26503GUL is "Matrix LED Driver" that is the most suitable for the cellular phone. It can control 7x17(119 dot) LED Matrix by internal 7-channel PMOS SWs and 17-channel LED drivers. It can control the luminance and firefly lighting of the LED matrix by the setting of the internal register. It supports SPI and I2C interface. VCSP50L3 (3.6mm \square 0.55mm height max), small and thin type chip size package. It adopts the very thin CSP package that is the most suitable for the slim phone.

●Features

- 1) LED Matrix driver (7x17)
 - It has 7-channel PMOS SWs and 17-channel current drivers with 1/7 timing driven sequentially.
 - Put ON/OFF(for every dot).
 - The current drivers can drive 0-20.00mA current with 16 step(for every dot).
 - 64 steps of the luminance control by PWM (common setting for all dots)
 - Continuous (TDMA off) lighting function for LED14-LED17
 - Easy register setting by A/B 2-side map for each dot.
- 2) Automatic Slope function
 - Cycle time, Slope time can be set for each dot.
- 3) 8-direction automatic scroll function.
- 4) Interface
 - SPI and I²C BUS FS mode(max 400kHz)Compatibility
 - For I²C mode, I²C Device address is selectable (74h or 75h)
- 5) Thermal shutdown
- 6) Small and thin CSP package
 - 48pin VCSP50L3 (3.6mm \square 0.55mm height max) 0.5mm ball pitch

*This chip is not designed to protect itself against radioactive rays.

*This material may be changed on its way to designing.

*This material is not the official specification.

●Absolute Maximum Ratings (Ta=25 °C)

Parameter	Symbol	Ratings	Unit
Maximum voltage (note2)	VMAX	7	V
Maximum voltage (note1)	VIOMAX	4.5	V
Power Dissipation (note3)	Pd	1550	mW
Operating Temperature Range	Topr	-40 ~ +85	°C
Storage Temperature Range	Tstg	-55 ~ +150	°C

note1) VIO, RESETB, CE, SDA, SCL, IFMODE, SYNC, CLKIN, CLKOUT, TEST1, TEST2, TEST3, TESTO, DO terminal

note2) Except the above

note3) Power dissipation deleting is 12.4mW/°C, when it's used in over 25°C. (ROHM's standard board has been mounted.)
The power dissipation of the IC has to be less than the one of the package.

●Operating Conditions (VBAT \geq VIO, VINSW \geq VBAT, Ta=-40~85 °C)

Parameter	Symbol	Limits	Unit
VBAT input voltage	VBAT	2.7 ~ 5.5	V
VINSW input voltage	VINSW	2.7 ~ 5.5	V
VIO pin voltage	VIO	1.65 ~ 5.5	V

●Electrical Characteristics (Unless otherwise specified, Ta=25°C, VBAT=3.6V, VINSW=3.6V, VIO=1.8V)

Parameter	Symbol	Limit			Unit	Condition
		Min.	Typ.	Max.		
[Circuit Current]						
VBAT Circuit current 1	IBAT1	-	0	3.0	μA	RESETB=0V, VIO=0V
VBAT Circuit current 2	IBAT2	-	0.8	5.0	μA	RESETB=0V, VIO=1.8V
VBAT Circuit current 3	IBAT3	-	2.0	3.5	mA	When LED1-17 are active with default settings.
[UVLO]						
UVLO Threshold	VUVLO	-	2.1	2.5	V	VBAT falling
UVLO Hysteresis	VHYUVLO	50	-	-	mV	
[LED Driver] (LED1-17)						
Maximum output current	ILEDMax1	-	20.00	-	mA	LED1-17 ,ISET=100kΩ
	ILEDMax2	-	30.00	-	mA	LED1-17 ,ISET=68kΩ
Output current	ILED	-7.0%	10.67	+7.0%	mA	I=10.67mA setting, VLED=1V, ISET = 100kΩ
LED current Matching	ILEDMT	-	-	5	%	ILEDMT=(ILEDMax-ILEDMin)/(ILEDMax+ILEDMin) I=10.67mA setting, VLED=1V ISET = 100kΩ
Driver pin voltage range	VLED1	0.2	-	VBAT-1.4	V	LED1-17 ,ISET=100kΩ
	VLED2	0.3	-	VBAT-1.4	V	LED1-17 ,ISET=68kΩ
LED OFF Leak current	ILKLED	-	-	1.0	μA	
[PMOS switch]						
Leak current at OFF	ILEAKP	-	-	1.0	μA	
Resistor at ON	RonP	-	1.0	-	Ω	Isw=170mA, VINSW=4.5V
[OSC]						
OSC frequency	fosc	0.96	1.2	1.44	MHz	
[CE, SYNC, CLKIN, IFMODE]						
L level input voltage	VIL1	-0.3	-	0.25 x VIO	V	
H level input voltage	VIH1	0.75 x VIO	-	VIO +0.3	V	
L level input current	Iin1	-	0	1	μA	Input voltage = from (0.1 x VIO) to (0.9 x VIO)
[SDA, SCL]						
L level input voltage	VIL2	-0.3	-	0.25 x VIO	V	
H level input voltage	VIH2	0.75 x VIO	-	VIO +0.3	V	
Input hysteresis	Vhys	0.05 x VIO	-	-	V	
L level output voltage (for SDA pin)	VOL2	0	-	0.3	V	At 3mA sink current
Input current	Iin2	-3	-	3	μA	Input voltage = from (0.1 x VIO) to (0.9 x VIO)
[RESETB]						
L level input voltage	VIL3	-0.3	-	0.25 x VIO	V	
H level input voltage	VIH3	0.75 x VIO	-	VIO +0.3	V	
Input current	Iin3	-	0	1	μA	Input voltage = from (0.1 x VIO) to (0.9 x VIO)
[CLKOUT]						
L level output voltage	VOL1	-	-	0.4	V	IOL=2mA
H level output voltage	VOH1	0.75 x VIO	-	-	V	IOH=-2mA

●Power Dissipation (on the ROHM's Standard Board)

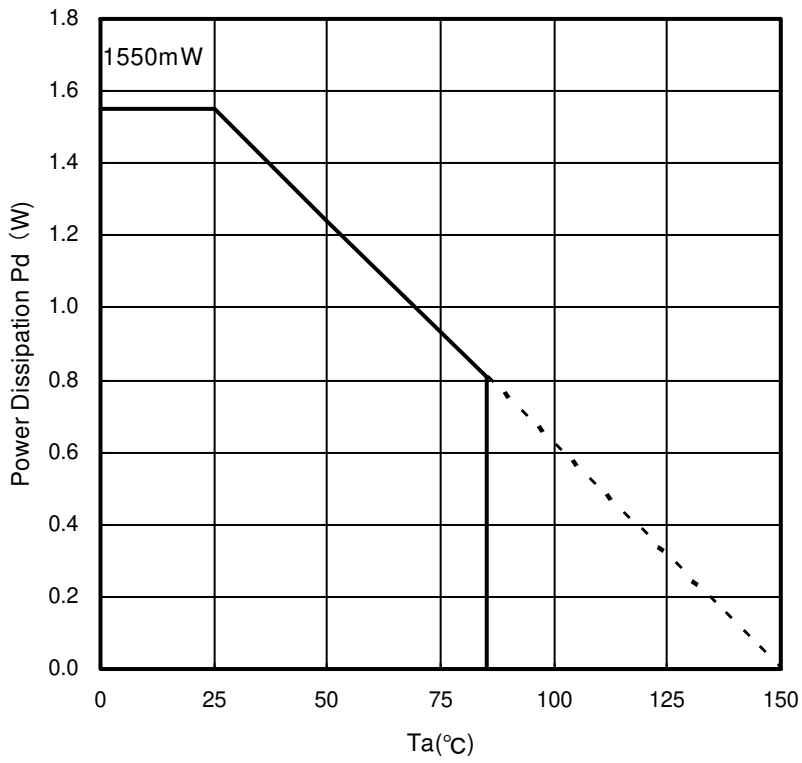

Fig.1

Information of the ROHM's standard board
Material: glass-epoxy
Size : 50mm × 58mm × 1.75mm(8th layer)
Wiring pattern figure Refer to after page.

●Block Diagram / Application Circuit Example 1

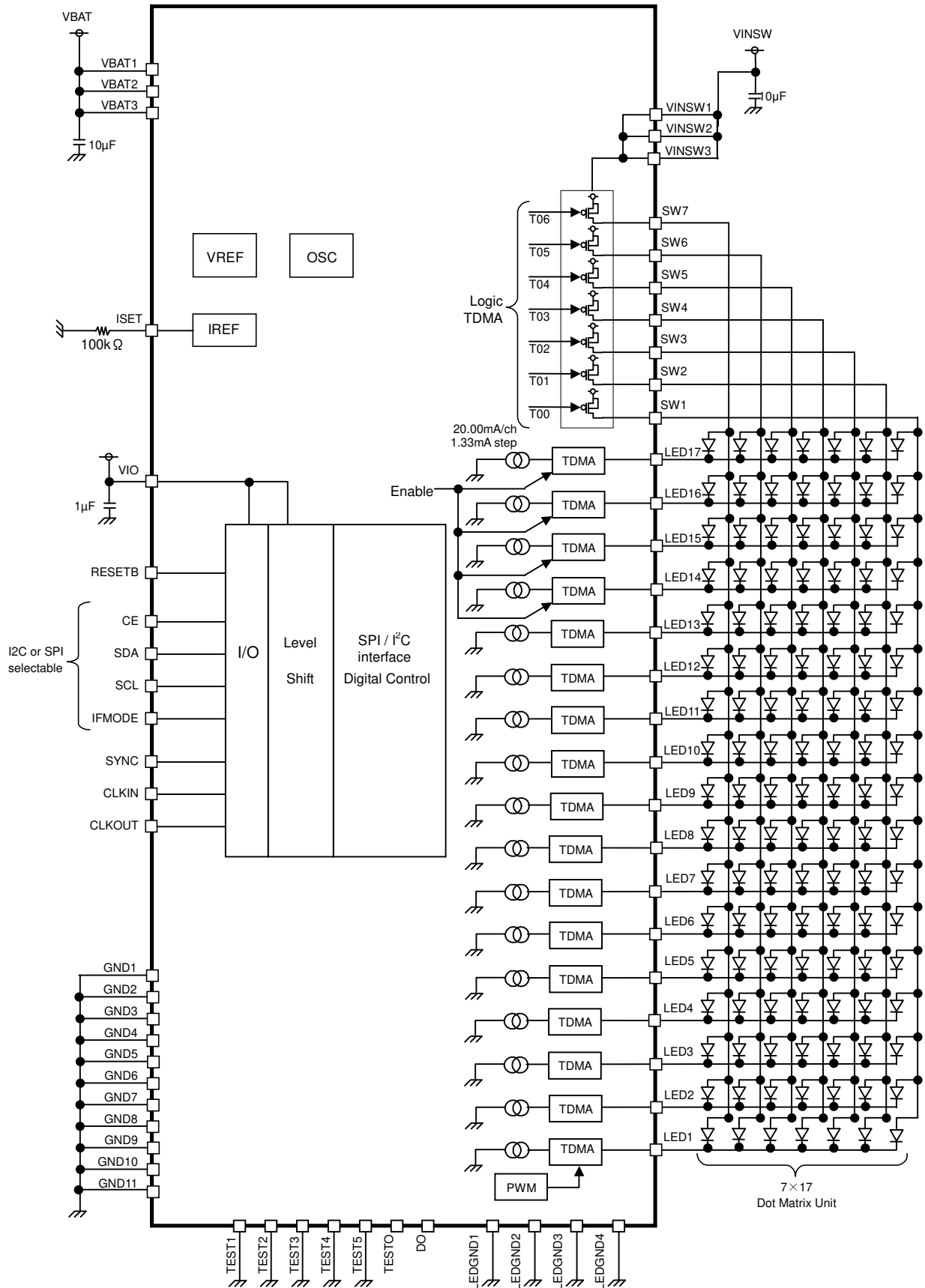

Fig.2 Block Diagram / Application Circuit example 1

●Block Diagram / Application Circuit Example 2

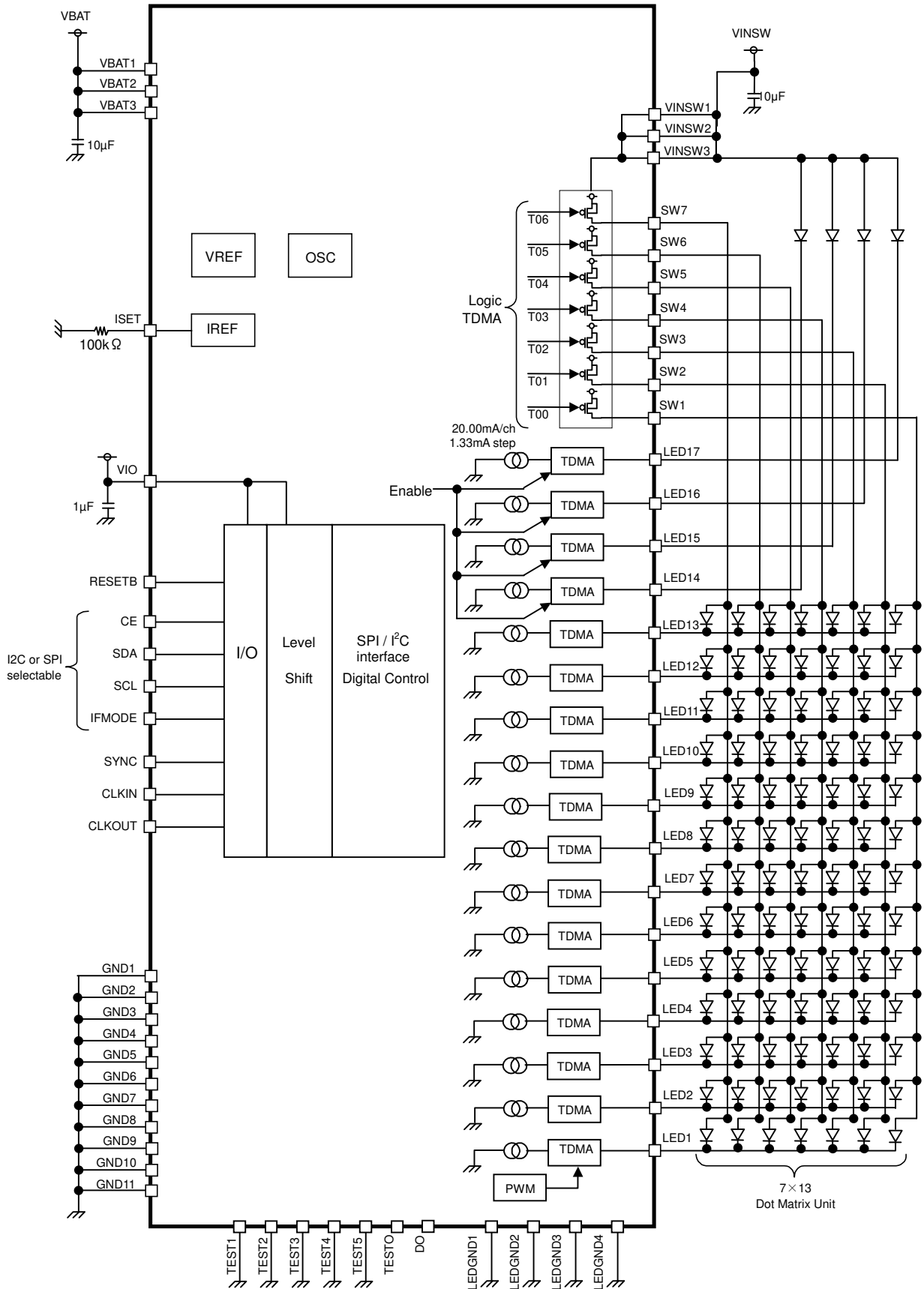
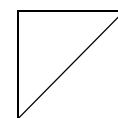

Fig.3 Block Diagram / Application Circuit example 2

●Pin Arrangement [Bottom View]

G	TEST4	VBAT1	LED11	LED13	LED15	LED17	TEST1
F	ISET	GND1	LED10	LED12	LED16	CLKOUT	TESTO
E	LED8	LED9	LEDGND2	TEST2	LED14	SDA	CE
D	LED6	LED7	LED5	LEDGND1	RESETB	SCL	VIO
C	LED4	LED3	/	SW4	SYNC	IFMODE	CLKIN
B	LED2	LED1	SW2	VINSW1	SW6	DO	VBAT2
A	TEST5	SW1	SW3	VINSW2	SW5	SW7	TEST3
	1	2	3	4	5	6	7

Total 48Balls



Index

●Package

48Pin VCSP50L3 CSP small package
SIZE : 3.60mm□
A ball pitch : 0.5mm
Height : 0.55mm max

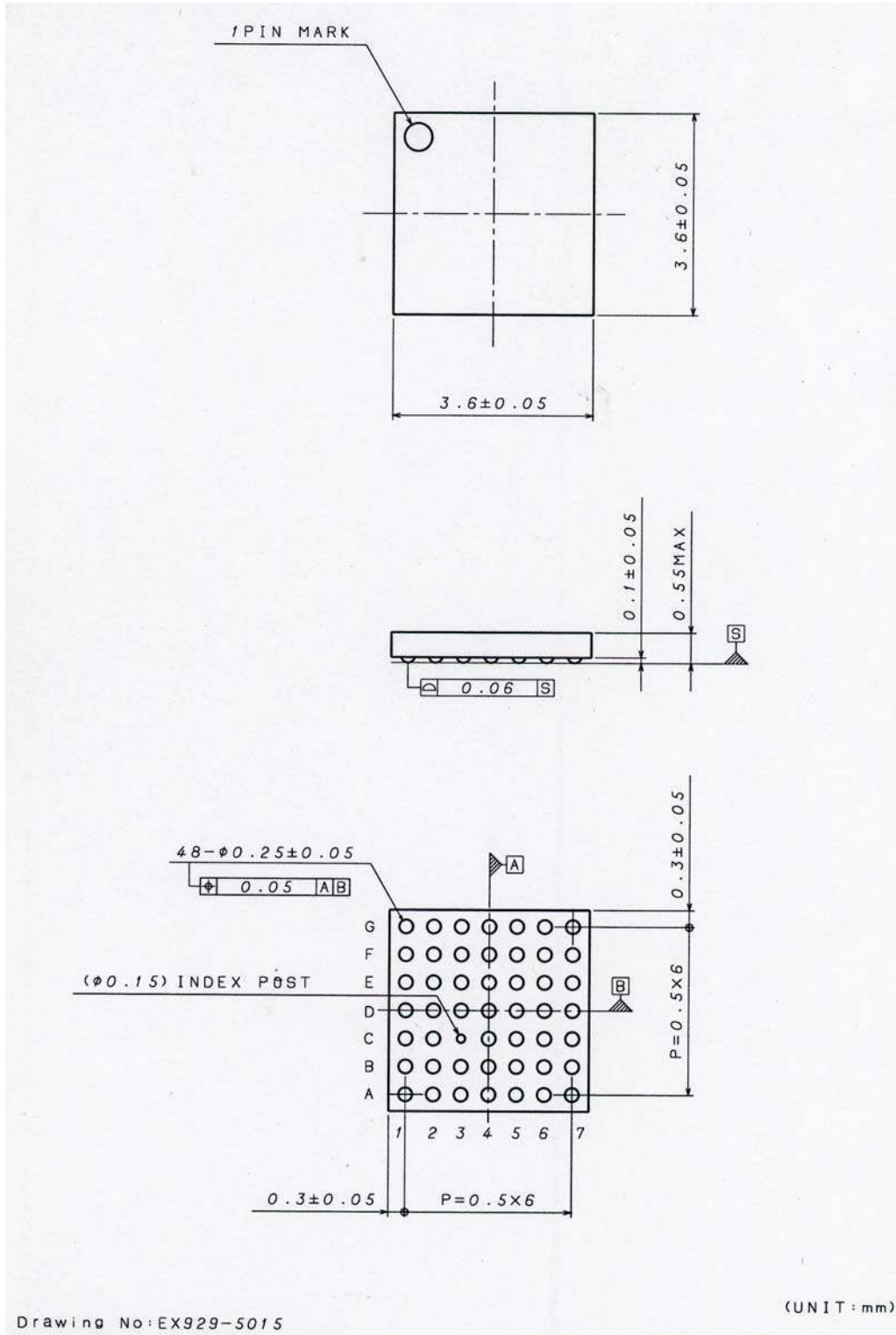

*INDEX POST has No Solder Ball

● Pin Functions

No	Ball No.	Pin Name	I/O	Pull down	Unused processing setting	ESD Diode		Functions	Equivalent Circuit
						For Power	For Ground		
1	A7	TEST3	I	94kohm	GND	VIO	GND	Test input pin 3	E
2	A1	TEST5	O	-	GND	VINSW	GND	Test input pin 5	I
3	B1	LED2	O	-	GND	-	GND	LED2 driver output	K
4	B2	LED1	O	-	GND	-	GND	LED1 driver output	K
5	B5	SW6	O	-	VINSW	VINSW	GND	P-MOS SW6 output	C
6	A6	SW7	O	-	VINSW	VINSW	GND	P-MOS SW 7 output	C
7	C2	LED3	O	-	GND	-	GND	LED3 driver output	K
8	D4	LEDGND1	-	-	-	VBAT	-	Ground	B
9	E4	TEST2	I	94kohm	GND	VIO	GND	Test input pin 2	E
10	A5	SW5	O	-	VINSW	VINSW	GND	P-MOS SW 5 output	C
11	C4	SW4	O	-	VINSW	VINSW	GND	P-MOS SW4 output	C
12	D3	LED5	O	-	GND	-	GND	LED5 driver output	K
13	D1	LED6	O	-	GND	-	GND	LED6 driver output	K
14	C1	LED4	O	-	GND	-	GND	LED4 driver output	K
15	A3	SW3	O	-	VINSW	VINSW	GND	P-MOS SW3 output	C
16	B3	SW2	O	-	VINSW	VINSW	GND	P-MOS SW2 output	C
17	A2	SW1	O	-	VINSW	VINSW	GND	P-MOS SW 1 output	C
18	B4	VINSW1	-	-	-	-	GND	Power supply for SW1-7	A
19	E3	LEDGND2	-	-	-	VBAT	-	Ground	B
20	D2	LED7	O	-	GND	-	GND	LED7 driver output	K
21	G2	VBAT1	-	-	-	-	GND	Battery is connected	A
22	D5	RESETB	I	-	GND	VIO	GND	Reset input pin (L: reset, H: reset cancel)	D
23	C7	CLKIN	I	-	GND	VIO	GND	External CLK input pin	D
24	C5	SYNC	I	-	GND	VIO	GND	External synchronous input pin	D
25	B6	DO	O	-	OPEN	VIO	GND	Test output pin2	G
26	E1	LED8	O	-	GND	-	GND	LED8 driver output	K
27	F1	ISET	I	-	-	VBAT	GND	LED Constant Current Driver Current setting pin	J
28	A4	VINSW2	-	-	-	-	GND	Power supply for SW1-7	A
29	G7	TEST1	I	94kohm	GND	VIO	GND	Test input pin 1	E
30	C6	IFMODE	I	-	GND	VIO	GND	I ² C/SPI select pin (L: I ² C, H: SPI)	D
31	D6	SCL	I	-	-	VIO	GND	SPI, I ² C CLK input pin	D
32	D7	VIO	-	-	-	-	GND	I/O Power supply is connected	A
33	E2	LED9	O	-	GND	-	GND	LED9 driver output	K
34	F3	LED10	O	-	GND	-	GND	LED10 driver output	K
35	G4	LED13	O	-	GND	-	GND	LED13 driver output	K
36	E5	LED14	O	-	GND	-	GND	LED14 driver output	K
37	F6	CLKOUT	O	-	OPEN	VIO	GND	Reference CLK output pin	G
38	E7	CE	I	-	GND	VIO	GND	SPI enable pin(H:Enable), or I ² C slave address selection (L: 74h, H: 75h)	D
39	E6	SDA	I/O	-	-	VIO	GND	SPI DATA input / I ² C DATA input-output pin	F
40	G1	TEST4	O	-	GND	VBAT	GND	Test input pin 4	H
41	G3	LED11	O	-	GND	-	GND	LED11 driver output	K
42	F4	LED12	O	-	GND	-	GND	LED12 driver output	K
43	F2	GND1	-	-	-	VBAT	-	Ground	B
44	G5	LED15	O	-	GND	-	GND	LED15 driver output	K
45	F5	LED16	O	-	GND	-	GND	LED16 driver output	K
46	G6	LED17	O	-	GND	-	GND	LED17 driver output	K
47	F7	TESTO	O	-	OPEN	VIO	GND	Test output pin1	G

48	B7	VBAT2	-	-	-	-	GND	Battery is connected	A
----	----	-------	---	---	---	---	-----	----------------------	---

* Please connect the unused LED pins to the ground.
 * It is prohibition to set the registers for unused LED.
 Total 48 pins

●Equivalent Circuit

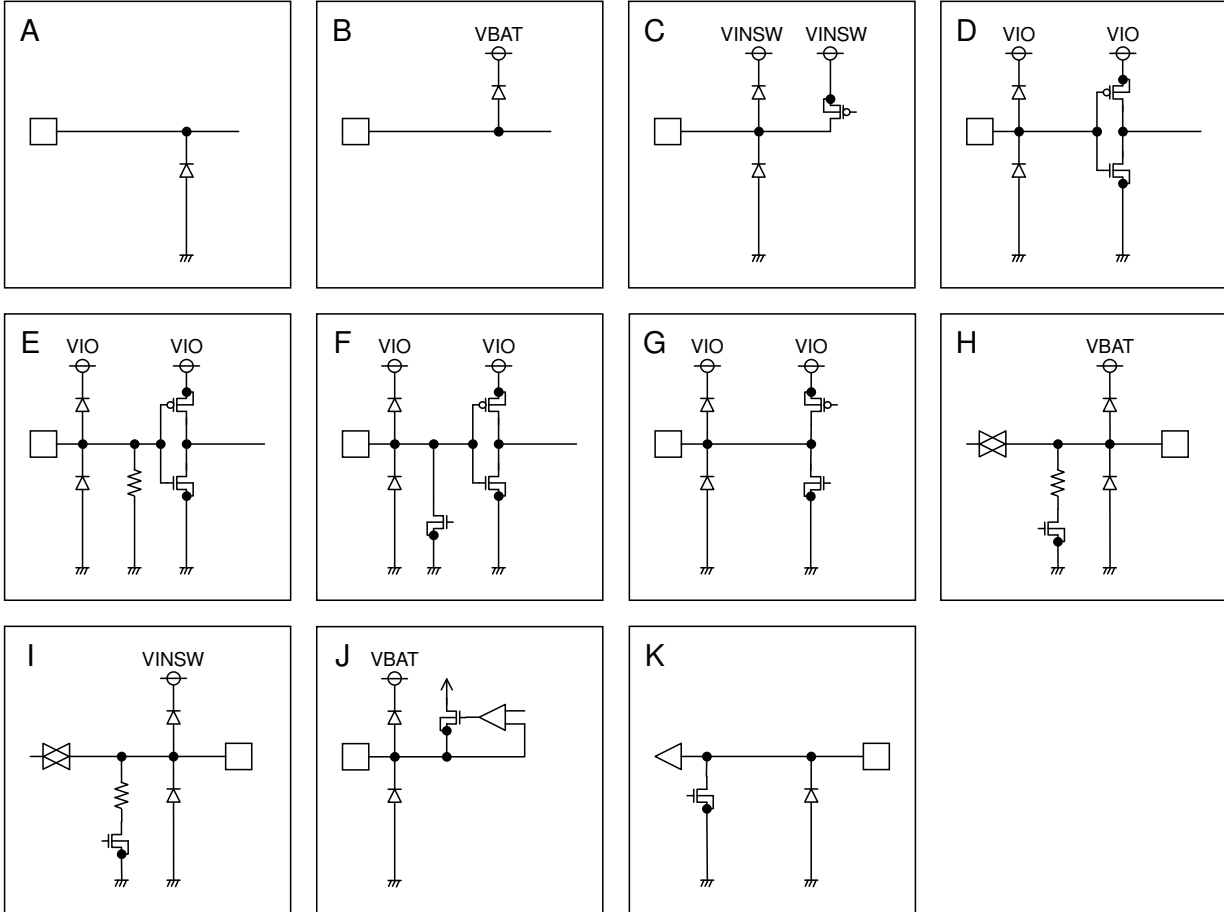

●Serial Interface

1. SPI format

- When IFMODE is set to “H”, it can interface with SPI format.
- The serial interface is four terminals (serial clock terminal (SCL), serial data input terminal (SDA), and chip selection input terminal (CE)).

(1)Write operation

- Data is taken into an internal shift register with rising edge of CLK. (Max of the frequency is 13MHz.)
- The receive data becomes enable in the “H” section of CE. (Active “H”.)
- The transmit data is forwarded (with MSB-First) in the order of write command “0”(1bit), the control register address (7bit) and data (8bit).

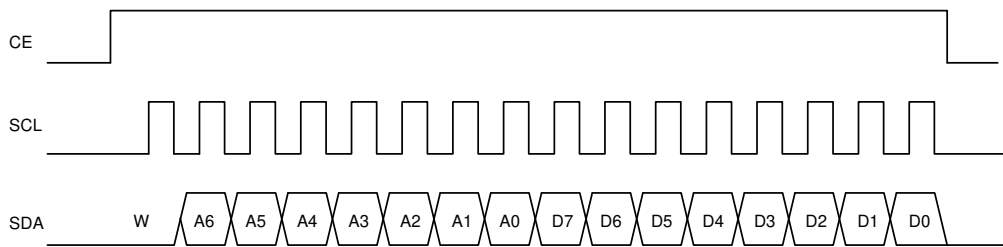

Fig.4 Writing format

(2)Timing diagram

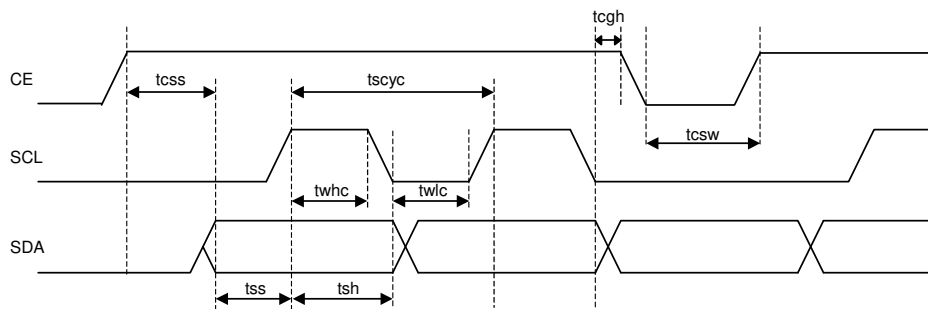

Fig.5 Timing diagram (SPI format)

(3) Electrical Characteristics (Unless otherwise specified, Ta=25°C, VBAT=3.6V, VINSW=3.6V, VIO=1.8V)

Parameter	Sym bol	Limit			Unit	Condition
		Min	Typ	Max		
SCL cycle time	tscyc	76	-	-	ns	
H period of SCL cycle	Twhc	35	-	-	ns	
L period of SCL cycle	Twlc	35	-	-	ns	
SDA setup time	Tss	38	-	-	ns	
SDA hold time	Tsh	38	-	-	ns	
Write interval	Tcsw	38	-	-	ns	
Write interval (after A or B RAM access)		2.1	-	-	μs	*1
		ECLK x 2	-	-	s	*2
CE setup time	Tcss	55	-	-	ns	
CE hold time	Tcgh	48	-	-	ns	

*1 When it used internal clock.

*2 When it used external clock. (ECLK means the cycle of external clock.)

2. I²C BUS format

When IFMODE is set to "L", it can interface with I²C BUS format.

(1) Slave address

CE	A7	A6	A5	A4	A3	A2	A1	R/W
L	1	1	1	0	1	0	0	0
H	1	1	1	0	1	0	1	

(2) Bit Transfer

SCL transfers 1-bit data during H. During H of SCL, SDA cannot be changed at the time of bit transfer. If SDA changes while SCL is H, START conditions or STOP conditions will occur and it will be interpreted as a control signal.

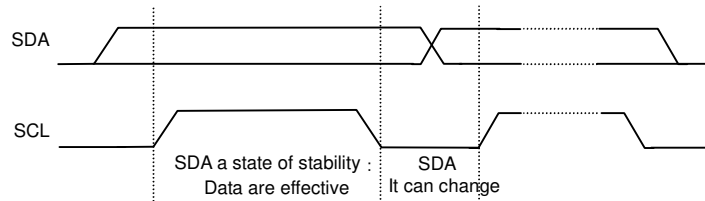

Fig.6 Bit transfer (I²C format)

(3) START and STOP condition

When SDA and SCL are H, data is not transferred on the I²C- bus. This condition indicates, if SDA changes from H to L while SCL has been H, it will become START (S) conditions, and an access start, if SDA changes from L to H while SCL has been H, it will become STOP (P) conditions and an access end.

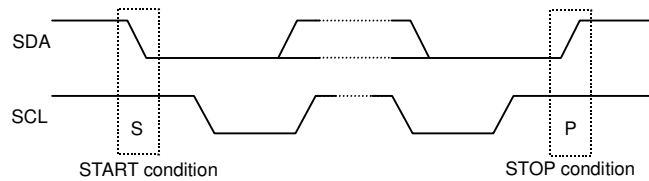

Fig.7 START/STOP condition (I²C format)

(4) Acknowledge

It transfers data 8 bits each after the occurrence of START condition. A transmitter opens SDA after transfer 8bits data, and a receiver returns the acknowledge signal by setting SDA to L.

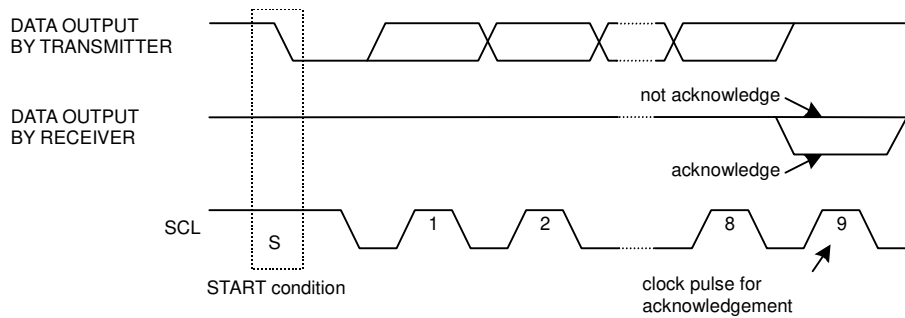
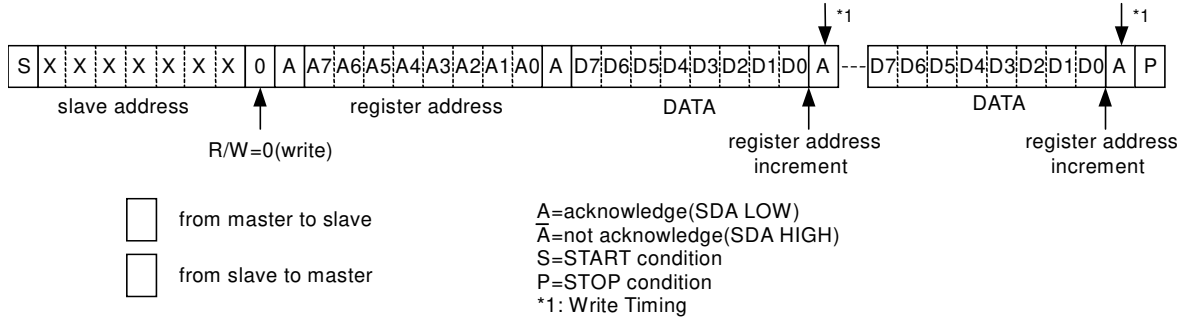

Fig.8 Acknowledge (I²C format)

(5) Writing protocol

A register address is transferred by the next 1 byte that transferred the slave address and the write-in command. The 3rd byte writes data in the internal register written in by the 2nd byte, and after 4th byte or, the increment of register address is carried out automatically. However, when a register address turns into the last address (77h), it is set to 00h by the next transmission. After the transmission end, the increment of the address is carried out.



(6) Timing diagram

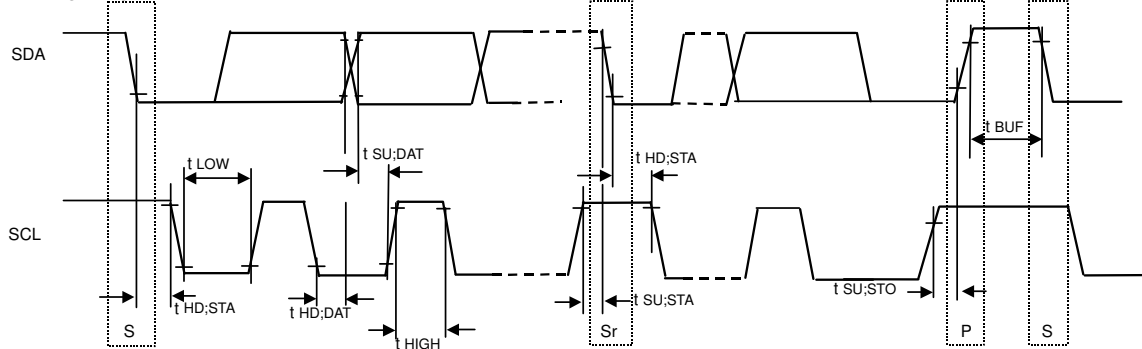

Fig.9 Timing diagram (I2C format)

(7) Electrical Characteristics (Unless otherwise specified, Ta=25°C, VBAT=3.6V, VINSW=3.6V, VIO=1.8V)

Parameter	Symbol	Standard-mode			Fast-mode			Unit
		Min.	Typ.	Max.	Min.	Typ.	Max.	
【I²C BUS format】								
SCL clock frequency	fSCL	0	-	100	0	-	400	kHz
LOW period of the SCL clock	tLOW	4.7	-	-	1.3	-	-	µs
HIGH period of the SCL clock	tHIGH	4.0	-	-	0.6	-	-	µs
Hold time (repeated) START condition After this period, the first clock is generated	tHD;STA	4.0	-	-	0.6	-	-	µs
Set-up time for a repeated START condition	tSU;STA	4.7	-	-	0.6	-	-	µs
Data hold time	tHD;DAT	0	-	3.45	0	-	0.9	µs
Data set-up time	tSU;DAT	250	-	-	100	-	-	ns
Set-up time for STOP condition	tSU;STO	4.0	-	-	0.6	-	-	µs
Bus free time between a STOP and START condition	tBUF	4.7	-	-	1.3	-	-	µs

●Register List

* Please be sure to write "0" in the register which is not assigned.

* It is prohibition to write data to the address which is not assigned.

Control register

Address	Default	D7	D6	D5	D4	D3	D2	D1	D0	Block	R/W	Remark	
00h	00h	-	-	-	-	-	-	-	SFTRST	RESET	W	Software Reset	
01h	00h	-	-	-	-	OSCEN	-	-	-	OSC	W	OSC ON/OFF control	
11h	00h	-	-	LED6ON	LED5ON	LED4ON	LED3ON	LED2ON	LED1ON	LED driver	W	LED1-6 Enable	
12h	00h	-	-	LED12ON	LED11ON	LED10ON	LED9ON	LED8ON	LED7ON		W	LED7-12 Enable	
13h	00h	-	-	-	LED17ON	LED16ON	LED15ON	LED14ON	LED13ON		W	LED13-17 Enable	
17h	0Fh	-	-	-	-	LED17 TDMAON	LED16 TDMAON	LED15 TDMAON	LED14 TDMAON		W	LED14-17 TDMA Enable	
20h	00h	-	-	PWMSET[5:0]							PWM	W	LED1-17PWM DutySetting
21h	00h	-	-	-	-	SYNCACT	SYNCON	CLKOUT	CLKIN	CLK	W	CLK selection, SYNC operation control	
2Dh	00h	-	-	-	-	-	PWMEN	SLPEN	SCLEN	MATRIX	W	PWM,SLOPE,SCROLL ON/OFF setting	
2Eh	00h	-	-	-	-	-	-	-	SCLRST		W	Reset SCROLL	
2Fh	00h	-	SCLSPEED[2:0]			UP	DOWN	RIGHT	LEFT		W	SCROLL Setting	
30h	00h	-	-	-	-	-	-	-	START	MATRIX	W	LED matrix control	
31h	00h	-	-	-	-	-	-	CLRB	CLRA		W	Matrix data clear	
7Fh	00h	-	-	-	-	-	IAB	OAB	RMCG	RMAP	W	Resister map change	

A-pattern register

Address	default	D7	D6	D5	D4	D3	D2	D1	D0	Block	R/W	Remark
01h	08h	SCYCA00[1:0]	SDLYA00[1:0]	ILEDA00SET[3:0]						MATRIX Data	W	Data for Matrix 00(DA00)
02h	08h	SCYCA01[1:0]	SDLYA01[1:0]	ILEDA01SET[3:0]							W	Data for Matrix 01(DA01)
03h	08h	SCYCA02[1:0]	SDLYA02[1:0]	ILEDA02SET[3:0]							W	Data for Matrix 02(DA02)
04h	08h	SCYCA03[1:0]	SDLYA03[1:0]	ILEDA03SET[3:0]							W	Data for Matrix 03(DA03)
05h	08h	SCYCA04[1:0]	SDLYA04[1:0]	ILEDA04SET[3:0]							W	Data for Matrix 04(DA04)
06h	08h	SCYCA05[1:0]	SDLYA05[1:0]	ILEDA05SET[3:0]							W	Data for Matrix 05(DA05)
07h	08h	SCYCA06[1:0]	SDLYA06[1:0]	ILEDA06SET[3:0]							W	Data for Matrix 06(DA06)
08h	08h	SCYCA10[1:0]	SDLYA10[1:0]	ILEDA10SET[3:0]							W	Data for Matrix 10(DA10)
09h	08h	SCYCA11[1:0]	SDLYA11[1:0]	ILEDA11SET[3:0]							W	Data for Matrix 11(DA11)
0Ah	08h	SCYCA12[1:0]	SDLYA12[1:0]	ILEDA12SET[3:0]							W	Data for Matrix 12(DA12)
0Bh	08h	SCYCA13[1:0]	SDLYA13[1:0]	ILEDA13SET[3:0]							W	Data for Matrix 13(DA13)
0Ch	08h	SCYCA14[1:0]	SDLYA14[1:0]	ILEDA14SET[3:0]							W	Data for Matrix 14(DA14)
0Dh	08h	SCYCA15[1:0]	SDLYA15[1:0]	ILEDA15SET[3:0]							W	Data for Matrix 15(DA15)
0Eh	08h	SCYCA16[1:0]	SDLYA16[1:0]	ILEDA16SET[3:0]							W	Data for Matrix 16(DA16)
0Fh	08h	SCYCA20[1:0]	SDLYA20[1:0]	ILEDA20SET[3:0]							W	Data for Matrix 20(DA20)
10h	08h	SCYCA21[1:0]	SDLYA21[1:0]	ILEDA21SET[3:0]							W	Data for Matrix 21(DA21)
11h	08h	SCYCA22[1:0]	SDLYA22[1:0]	ILEDA22SET[3:0]							W	Data for Matrix 22(DA22)
12h	08h	SCYCA23[1:0]	SDLYA23[1:0]	ILEDA23SET[3:0]							W	Data for Matrix 23(DA23)
13h	08h	SCYCA24[1:0]	SDLYA24[1:0]	ILEDA24SET[3:0]							W	Data for Matrix 24(DA24)
14h	08h	SCYCA25[1:0]	SDLYA25[1:0]	ILEDA25SET[3:0]							W	Data for Matrix 25(DA25)
15h	08h	SCYCA26[1:0]	SDLYA26[1:0]	ILEDA26SET[3:0]							W	Data for Matrix 26(DA26)
16h	08h	SCYCA30[1:0]	SDLYA30[1:0]	ILEDA30SET[3:0]							W	Data for Matrix 30(DA30)
17h	08h	SCYCA31[1:0]	SDLYA31[1:0]	ILEDA31SET[3:0]							W	Data for Matrix 31(DA31)
18h	08h	SCYCA32[1:0]	SDLYA32[1:0]	ILEDA32SET[3:0]							W	Data for Matrix 32(DA32)
19h	08h	SCYCA33[1:0]	SDLYA33[1:0]	ILEDA33SET[3:0]							W	Data for Matrix 33(DA33)
1Ah	08h	SCYCA34[1:0]	SDLYA34[1:0]	ILEDA34SET[3:0]							W	Data for Matrix 34(DA34)
1Bh	08h	SCYCA35[1:0]	SDLYA35[1:0]	ILEDA35SET[3:0]							W	Data for Matrix 35(DA35)
1Ch	08h	SCYCA36[1:0]	SDLYA36[1:0]	ILEDA36SET[3:0]							W	Data for Matrix 36(DA36)
1Dh	08h	SCYCA40[1:0]	SDLYA40[1:0]	ILEDA40SET[3:0]							W	Data for Matrix 40(DA40)
1Eh	08h	SCYCA41[1:0]	SDLYA41[1:0]	ILEDA41SET[3:0]							W	Data for Matrix 41(DA41)
1Fh	08h	SCYCA42[1:0]	SDLYA42[1:0]	ILEDA42SET[3:0]							W	Data for Matrix 42(DA42)
20h	08h	SCYCA43[1:0]	SDLYA43[1:0]	ILEDA43SET[3:0]							W	Data for Matrix 43(DA43)
21h	08h	SCYCA44[1:0]	SDLYA44[1:0]	ILEDA44SET[3:0]							W	Data for Matrix 44(DA44)
22h	08h	SCYCA45[1:0]	SDLYA45[1:0]	ILEDA45SET[3:0]							W	Data for Matrix 45(DA45)
23h	08h	SCYCA46[1:0]	SDLYA46[1:0]	ILEDA46SET[3:0]							W	Data for Matrix 46(DA46)
24h	08h	SCYCA50[1:0]	SDLYA50[1:0]	ILEDA50SET[3:0]							W	Data for Matrix 50(DA50)
25h	08h	SCYCA51[1:0]	SDLYA51[1:0]	ILEDA51SET[3:0]							W	Data for Matrix 51(DA51)
26h	08h	SCYCA52[1:0]	SDLYA52[1:0]	ILEDA52SET[3:0]							W	Data for Matrix 52(DA52)
27h	08h	SCYCA53[1:0]	SDLYA53[1:0]	ILEDA53SET[3:0]							W	Data for Matrix 53(DA53)
28h	08h	SCYCA54[1:0]	SDLYA54[1:0]	ILEDA54SET[3:0]							W	Data for Matrix 54(DA54)
29h	08h	SCYCA55[1:0]	SDLYA55[1:0]	ILEDA55SET[3:0]							W	Data for Matrix 55(DA55)
2Ah	08h	SCYCA56[1:0]	SDLYA56[1:0]	ILEDA56SET[3:0]							W	Data for Matrix 56(DA56)
2Bh	08h	SCYCA60[1:0]	SDLYA60[1:0]	ILEDA60SET[3:0]							W	Data for Matrix 60(DA60)
2Ch	08h	SCYCA61[1:0]	SDLYA61[1:0]	ILEDA61SET[3:0]							W	Data for Matrix 61(DA61)
2Dh	08h	SCYCA62[1:0]	SDLYA62[1:0]	ILEDA62SET[3:0]							W	Data for Matrix 62(DA62)
2Eh	08h	SCYCA63[1:0]	SDLYA63[1:0]	ILEDA63SET[3:0]							W	Data for Matrix 63(DA63)
2Fh	08h	SCYCA64[1:0]	SDLYA64[1:0]	ILEDA64SET[3:0]							W	Data for Matrix 64(DA64)
30h	08h	SCYCA65[1:0]	SDLYA65[1:0]	ILEDA65SET[3:0]							W	Data for Matrix 65(DA65)

Address	default	D7	D6	D5	D4	D3	D2	D1	D0	Block	R/W	Remark
31h	08h	SCYCA66[1:0]	SDLYA66[1:0]	ILEDAA66SET[3:0]						MATRIX Data	W	Data for Matrix 66(DA66)
32h	08h	SCYCA70[1:0]	SDLYA70[1:0]	ILEDAA70SET[3:0]							W	Data for Matrix 70(DA70)
33h	08h	SCYCA71[1:0]	SDLYA71[1:0]	ILEDAA71SET[3:0]							W	Data for Matrix 71(DA71)
34h	08h	SCYCA72[1:0]	SDLYA72[1:0]	ILEDAA72SET[3:0]							W	Data for Matrix 72(DA72)
35h	08h	SCYCA73[1:0]	SDLYA73[1:0]	ILEDAA73SET[3:0]							W	Data for Matrix 73(DA73)
36h	08h	SCYCA74[1:0]	SDLYA74[1:0]	ILEDAA74SET[3:0]							W	Data for Matrix 74(DA74)
37h	08h	SCYCA75[1:0]	SDLYA75[1:0]	ILEDAA75SET[3:0]							W	Data for Matrix 75(DA75)
38h	08h	SCYCA76[1:0]	SDLYA76[1:0]	ILEDAA76SET[3:0]							W	Data for Matrix 76(DA76)
39h	08h	SCYCA80[1:0]	SDLYA80[1:0]	ILEDAA80SET[3:0]							W	Data for Matrix 80(DA80)
3Ah	08h	SCYCA81[1:0]	SDLYA81[1:0]	ILEDAA81SET[3:0]							W	Data for Matrix 81(DA81)
3Bh	08h	SCYCA82[1:0]	SDLYA82[1:0]	ILEDAA82SET[3:0]							W	Data for Matrix 82(DA82)
3Ch	08h	SCYCA83[1:0]	SDLYA83[1:0]	ILEDAA83SET[3:0]							W	Data for Matrix 83(DA83)
3Dh	08h	SCYCA84[1:0]	SDLYA84[1:0]	ILEDAA84SET[3:0]							W	Data for Matrix 84(DA84)
3Eh	08h	SCYCA85[1:0]	SDLYA85[1:0]	ILEDAA85SET[3:0]							W	Data for Matrix 85(DA85)
3Fh	08h	SCYCA86[1:0]	SDLYA86[1:0]	ILEDAA86SET[3:0]							W	Data for Matrix 86(DA86)
40h	08h	SCYCA90[1:0]	SDLYA90[1:0]	ILEDAA90SET[3:0]							W	Data for Matrix 90(DA90)
41h	08h	SCYCA91[1:0]	SDLYA91[1:0]	ILEDAA91SET[3:0]							W	Data for Matrix 91(DA91)
42h	08h	SCYCA92[1:0]	SDLYA92[1:0]	ILEDAA92SET[3:0]							W	Data for Matrix 92(DA92)
43h	08h	SCYCA93[1:0]	SDLYA93[1:0]	ILEDAA93SET[3:0]							W	Data for Matrix 93(DA93)
44h	08h	SCYCA94[1:0]	SDLYA94[1:0]	ILEDAA94SET[3:0]							W	Data for Matrix 94(DA94)
45h	08h	SCYCA95[1:0]	SDLYA95[1:0]	ILEDAA95SET[3:0]							W	Data for Matrix 95(DA95)
46h	08h	SCYCA96[1:0]	SDLYA96[1:0]	ILEDAA96SET[3:0]							W	Data for Matrix 96(DA96)
47h	08h	SCYCAA0[1:0]	SDLYAA0[1:0]	ILEDAA0SET[3:0]							W	Data for Matrix A0(DAA0)
48h	08h	SCYCAA1[1:0]	SDLYAA1[1:0]	ILEDAA1SET[3:0]							W	Data for Matrix A1(DAA1)
49h	08h	SCYCAA2[1:0]	SDLYAA2[1:0]	ILEDAA2SET[3:0]							W	Data for Matrix A2(DAA2)
4Ah	08h	SCYCAA3[1:0]	SDLYAA3[1:0]	ILEDAA3SET[3:0]							W	Data for Matrix A3(DAA3)
4Bh	08h	SCYCAA4[1:0]	SDLYAA4[1:0]	ILEDAA4SET[3:0]							W	Data for Matrix A4(DAA4)
4Ch	08h	SCYCAA5[1:0]	SDLYAA5[1:0]	ILEDAA5SET[3:0]							W	Data for Matrix A5(DAA5)
4Dh	08h	SCYCAA6[1:0]	SDLYAA6[1:0]	ILEDAA6SET[3:0]							W	Data for Matrix A6(DAA6)
4Eh	08h	SCYCAB0[1:0]	SDLYAB0[1:0]	ILEDAB0SET[3:0]							W	Data for Matrix B0(DAB0)
4Fh	08h	SCYCAB1[1:0]	SDLYAB1[1:0]	ILEDAB1SET[3:0]							W	Data for Matrix B1(DAB1)
50h	08h	SCYCAB2[1:0]	SDLYAB2[1:0]	ILEDAB2SET[3:0]							W	Data for Matrix B2(DAB2)
51h	08h	SCYCAB3[1:0]	SDLYAB3[1:0]	ILEDAB3SET[3:0]							W	Data for Matrix B3(DAB3)
52h	08h	SCYCAB4[1:0]	SDLYAB4[1:0]	ILEDAB4SET[3:0]							W	Data for Matrix B4(DAB4)
53h	08h	SCYCAB5[1:0]	SDLYAB5[1:0]	ILEDAB5SET[3:0]							W	Data for Matrix B5(DAB5)
54h	08h	SCYCAB6[1:0]	SDLYAB6[1:0]	ILEDAB6SET[3:0]							W	Data for Matrix B6(DAB6)
55h	08h	SCYCAC0[1:0]	SDLYAC0[1:0]	ILEDAC0SET[3:0]							W	Data for Matrix C0(DAC0)
56h	08h	SCYCAC1[1:0]	SDLYAC1[1:0]	ILEDAC1SET[3:0]							W	Data for Matrix C1(DAC1)
57h	08h	SCYCAC2[1:0]	SDLYAC2[1:0]	ILEDAC2SET[3:0]							W	Data for Matrix C2(DAC2)
58h	08h	SCYCAC3[1:0]	SDLYAC3[1:0]	ILEDAC3SET[3:0]							W	Data for Matrix C3(DAC3)
59h	08h	SCYCAC4[1:0]	SDLYAC4[1:0]	ILEDAC4SET[3:0]							W	Data for Matrix C4(DAC4)
5Ah	08h	SCYCAC5[1:0]	SDLYAC5[1:0]	ILEDAC5SET[3:0]							W	Data for Matrix C5(DAC5)
5Bh	08h	SCYCAC6[1:0]	SDLYAC6[1:0]	ILEDAC6SET[3:0]							W	Data for Matrix C6(DAC6)
5Ch	08h	SCYCAD0[1:0]	SDLYAD0[1:0]	ILEDAD0SET[3:0]							W	Data for Matrix D0(DAD0)
5Dh	08h	SCYCAD1[1:0]	SDLYAD1[1:0]	ILEDAD1SET[3:0]							W	Data for Matrix D1(DAD1)
5Eh	08h	SCYCAD2[1:0]	SDLYAD2[1:0]	ILEDAD2SET[3:0]							W	Data for Matrix D2(DAD2)
5Fh	08h	SCYCAD3[1:0]	SDLYAD3[1:0]	ILEDAD3SET[3:0]							W	Data for Matrix D3(DAD3)
60h	08h	SCYCAD4[1:0]	SDLYAD4[1:0]	ILEDAD4SET[3:0]							W	Data for Matrix D4(DAD4)

Address	default	D7	D6	D5	D4	D3	D2	D1	D0	Block	R/W	Remark
61h	08h	SCYCAD5[1:0]	SDLYAD5[1:0]	ILEDAD5SET[3:0]						MATRIX Data	W	Data for Matrix D5(DAD5)
62h	08h	SCYCAD6[1:0]	SDLYAD6[1:0]	ILEDAD6SET[3:0]							W	Data for Matrix D6(DAD6)
63h	08h	SCYCAE0[1:0]	SDLYAE0[1:0]	ILEDAE0SET[3:0]							W	Data for Matrix E0(DAE0)
64h	08h	SCYCAE1[1:0]	SDLYAE1[1:0]	ILEDAE1SET[3:0]							W	Data for Matrix E1(DAE1)
65h	08h	SCYCAE2[1:0]	SDLYAE2[1:0]	ILEDAE2SET[3:0]							W	Data for Matrix E2(DAE2)
66h	08h	SCYCAE3[1:0]	SDLYAE3[1:0]	ILEDAE3SET[3:0]							W	Data for Matrix E3(DAE3)
67h	08h	SCYCAE4[1:0]	SDLYAE4[1:0]	ILEDAE4SET[3:0]							W	Data for Matrix E4(DAE4)
68h	08h	SCYCAE5[1:0]	SDLYAE5[1:0]	ILEDAE5SET[3:0]							W	Data for Matrix E5(DAE5)
69h	08h	SCYCAE6[1:0]	SDLYAE6[1:0]	ILEDAE6SET[3:0]							W	Data for Matrix E6(DAE6)
6Ah	08h	SCYCAF0[1:0]	SDLYAF0[1:0]	ILEDAF0SET[3:0]							W	Data for Matrix F0(DAF0)
6Bh	08h	SCYCAF1[1:0]	SDLYAF1[1:0]	ILEDAF1SET[3:0]							W	Data for Matrix F1(DAF1)
6Ch	08h	SCYCAF2[1:0]	SDLYAF2[1:0]	ILEDAF2SET[3:0]							W	Data for Matrix F2(DAF2)
6Dh	08h	SCYCAF3[1:0]	SDLYAF3[1:0]	ILEDAF3SET[3:0]							W	Data for Matrix F3(DAF3)
6Eh	08h	SCYCAF4[1:0]	SDLYAF4[1:0]	ILEDAF4SET[3:0]							W	Data for Matrix F4(DAF4)
6Fh	08h	SCYCAF5[1:0]	SDLYAF5[1:0]	ILEDAF5SET[3:0]							W	Data for Matrix F5(DAF5)
70h	08h	SCYCAF6[1:0]	SDLYAF6[1:0]	ILEDAF6SET[3:0]							W	Data for Matrix F6(DAF6)
71h	08h	SCYCAG0[1:0]	SDLYAG0[1:0]	ILEDAG0SET[3:0]							W	Data for Matrix G0(DAG0)
72h	08h	SCYCAG1[1:0]	SDLYAG1[1:0]	ILEDAG1SET[3:0]							W	Data for Matrix G1(DAG1)
73h	08h	SCYCAG2[1:0]	SDLYAG2[1:0]	ILEDAG2SET[3:0]							W	Data for Matrix G2(DAG2)
74h	08h	SCYCAG3[1:0]	SDLYAG3[1:0]	ILEDAG3SET[3:0]							W	Data for Matrix G3(DAG3)
75h	08h	SCYCAG4[1:0]	SDLYAG4[1:0]	ILEDAG4SET[3:0]						W	Data for Matrix G4(DAG4)	
76h	08h	SCYCAG5[1:0]	SDLYAG5[1:0]	ILEDAG5SET[3:0]						W	Data for Matrix G5(DAG5)	
77h	08h	SCYCAG6[1:0]	SDLYAG6[1:0]	ILEDAG6SET[3:0]						W	Data for Matrix G6(DAG6)	

B-pattern register

Address	default	D7	D6	D5	D4	D3	D2	D1	D0	Block	R/W	Remark
01h	08h	SCYCB00[1:0]	SDLYB00[1:0]	ILEDDB00SET[3:0]						MATRIX Data	W	Data for Matrix 00(DB00)
02h	08h	SCYCB01[1:0]	SDLYB01[1:0]	ILEDDB01SET[3:0]							W	Data for Matrix 01(DB01)
03h	08h	SCYCB02[1:0]	SDLYB02[1:0]	ILEDDB02SET[3:0]							W	Data for Matrix 02(DB02)
04h	08h	SCYCB03[1:0]	SDLYB03[1:0]	ILEDDB03SET[3:0]							W	Data for Matrix 03(DB03)
05h	08h	SCYCB04[1:0]	SDLYB04[1:0]	ILEDDB04SET[3:0]							W	Data for Matrix 04(DB04)
06h	08h	SCYCB05[1:0]	SDLYB05[1:0]	ILEDDB05SET[3:0]							W	Data for Matrix 05(DB05)
07h	08h	SCYCB06[1:0]	SDLYB06[1:0]	ILEDDB06SET[3:0]							W	Data for Matrix 06(DB06)
08h	08h	SCYCB10[1:0]	SDLYB10[1:0]	ILEDDB10SET[3:0]							W	Data for Matrix 10(DB10)
09h	08h	SCYCB11[1:0]	SDLYB11[1:0]	ILEDDB11SET[3:0]							W	Data for Matrix 11(DB11)
0Ah	08h	SCYCB12[1:0]	SDLYB12[1:0]	ILEDDB12SET[3:0]							W	Data for Matrix 12(DB12)
0Bh	08h	SCYCB13[1:0]	SDLYB13[1:0]	ILEDDB13SET[3:0]							W	Data for Matrix 13(DB13)
0Ch	08h	SCYCB14[1:0]	SDLYB14[1:0]	ILEDDB14SET[3:0]							W	Data for Matrix 14(DB14)
0Dh	08h	SCYCB15[1:0]	SDLYB15[1:0]	ILEDDB15SET[3:0]							W	Data for Matrix 15(DB15)
0Eh	08h	SCYCB16[1:0]	SDLYB16[1:0]	ILEDDB16SET[3:0]							W	Data for Matrix 16(DB16)
0Fh	08h	SCYCB20[1:0]	SDLYB20[1:0]	ILEDDB20SET[3:0]							W	Data for Matrix 20(DB20)
10h	08h	SCYCB21[1:0]	SDLYB21[1:0]	ILEDDB21SET[3:0]							W	Data for Matrix 21(DB21)
11h	08h	SCYCB22[1:0]	SDLYB22[1:0]	ILEDDB22SET[3:0]							W	Data for Matrix 22(DB22)
12h	08h	SCYCB23[1:0]	SDLYB23[1:0]	ILEDDB23SET[3:0]							W	Data for Matrix 23(DB23)
13h	08h	SCYCB24[1:0]	SDLYB24[1:0]	ILEDDB24SET[3:0]							W	Data for Matrix 24(DB24)
14h	08h	SCYCB25[1:0]	SDLYB25[1:0]	ILEDDB25SET[3:0]							W	Data for Matrix 25(DB25)
15h	08h	SCYCB26[1:0]	SDLYB26[1:0]	ILEDDB26SET[3:0]							W	Data for Matrix 26(DB26)
16h	08h	SCYCB30[1:0]	SDLYB30[1:0]	ILEDDB30SET[3:0]							W	Data for Matrix 30(DB30)
17h	08h	SCYCB31[1:0]	SDLYB31[1:0]	ILEDDB31SET[3:0]							W	Data for Matrix 31(DB31)
18h	08h	SCYCB32[1:0]	SDLYB32[1:0]	ILEDDB32SET[3:0]							W	Data for Matrix 32(DB32)
19h	08h	SCYCB33[1:0]	SDLYB33[1:0]	ILEDDB33SET[3:0]							W	Data for Matrix 33(DB33)
1Ah	08h	SCYCB34[1:0]	SDLYB34[1:0]	ILEDDB34SET[3:0]							W	Data for Matrix 34(DB34)
1Bh	08h	SCYCB35[1:0]	SDLYB35[1:0]	ILEDDB35SET[3:0]							W	Data for Matrix 35(DB35)
1Ch	08h	SCYCB36[1:0]	SDLYB36[1:0]	ILEDDB36SET[3:0]							W	Data for Matrix 36(DB36)
1Dh	08h	SCYCB40[1:0]	SDLYB40[1:0]	ILEDDB40SET[3:0]							W	Data for Matrix 40(DB40)
1Eh	08h	SCYCB41[1:0]	SDLYB41[1:0]	ILEDDB41SET[3:0]							W	Data for Matrix 41(DB41)
1Fh	08h	SCYCB42[1:0]	SDLYB42[1:0]	ILEDDB42SET[3:0]							W	Data for Matrix 42(DB42)
20h	08h	SCYCB43[1:0]	SDLYB43[1:0]	ILEDDB43SET[3:0]							W	Data for Matrix 43(DB43)
21h	08h	SCYCB44[1:0]	SDLYB44[1:0]	ILEDDB44SET[3:0]							W	Data for Matrix 44(DB44)
22h	08h	SCYCB45[1:0]	SDLYB45[1:0]	ILEDDB45SET[3:0]							W	Data for Matrix 45(DB45)
23h	08h	SCYCB46[1:0]	SDLYB46[1:0]	ILEDDB46SET[3:0]							W	Data for Matrix 46(DB46)
24h	08h	SCYCB50[1:0]	SDLYB50[1:0]	ILEDDB50SET[3:0]							W	Data for Matrix 50(DB50)
25h	08h	SCYCB51[1:0]	SDLYB51[1:0]	ILEDDB51SET[3:0]							W	Data for Matrix 51(DB51)
26h	08h	SCYCB52[1:0]	SDLYB52[1:0]	ILEDDB52SET[3:0]							W	Data for Matrix 52(DB52)
27h	08h	SCYCB53[1:0]	SDLYB53[1:0]	ILEDDB53SET[3:0]							W	Data for Matrix 53(DB53)
28h	08h	SCYCB54[1:0]	SDLYB54[1:0]	ILEDDB54SET[3:0]							W	Data for Matrix 54(DB54)
29h	08h	SCYCB55[1:0]	SDLYB55[1:0]	ILEDDB55SET[3:0]							W	Data for Matrix 55(DB55)
2Ah	08h	SCYCB56[1:0]	SDLYB56[1:0]	ILEDDB56SET[3:0]							W	Data for Matrix 56(DB56)
2Bh	08h	SCYCB60[1:0]	SDLYB60[1:0]	ILEDDB60SET[3:0]							W	Data for Matrix 60(DB60)
2Ch	08h	SCYCB61[1:0]	SDLYB61[1:0]	ILEDDB61SET[3:0]							W	Data for Matrix 61(DB61)
2Dh	08h	SCYCB62[1:0]	SDLYB62[1:0]	ILEDDB62SET[3:0]							W	Data for Matrix 62(DB62)
2Eh	08h	SCYCB63[1:0]	SDLYB63[1:0]	ILEDDB63SET[3:0]							W	Data for Matrix 63(DB63)
2Fh	08h	SCYCB64[1:0]	SDLYB64[1:0]	ILEDDB64SET[3:0]							W	Data for Matrix 64(DB64)
30h	08h	SCYCB65[1:0]	SDLYB65[1:0]	ILEDDB65SET[3:0]							W	Data for Matrix 65(DB65)

Address	default	D7	D6	D5	D4	D3	D2	D1	D0	Block	R/W	Remark
31h	08h	SCYCB66[1:0]	SDLYB66[1:0]	ILEDDB66SET[3:0]						MATRIX Data	W	Data for Matrix 66(DB66)
32h	08h	SCYCB70[1:0]	SDLYB70[1:0]	ILEDDB70SET[3:0]							W	Data for Matrix 70(DB70)
33h	08h	SCYCB71[1:0]	SDLYB71[1:0]	ILEDDB71SET[3:0]							W	Data for Matrix 71(DB71)
34h	08h	SCYCB72[1:0]	SDLYB72[1:0]	ILEDDB72SET[3:0]							W	Data for Matrix 72(DB72)
35h	08h	SCYCB73[1:0]	SDLYB73[1:0]	ILEDDB73SET[3:0]							W	Data for Matrix 73(DB73)
36h	08h	SCYCB74[1:0]	SDLYB74[1:0]	ILEDDB74SET[3:0]							W	Data for Matrix 74(DB74)
37h	08h	SCYCB75[1:0]	SDLYB75[1:0]	ILEDDB75SET[3:0]							W	Data for Matrix 75(DB75)
38h	08h	SCYCB76[1:0]	SDLYB76[1:0]	ILEDDB76SET[3:0]							W	Data for Matrix 76(DB76)
39h	08h	SCYCB80[1:0]	SDLYB80[1:0]	ILEDDB80SET[3:0]							W	Data for Matrix 80(DB80)
3Ah	08h	SCYCB81[1:0]	SDLYB81[1:0]	ILEDDB81SET[3:0]							W	Data for Matrix 81(DB81)
3Bh	08h	SCYCB82[1:0]	SDLYB82[1:0]	ILEDDB82SET[3:0]							W	Data for Matrix 82(DB82)
3Ch	08h	SCYCB83[1:0]	SDLYB83[1:0]	ILEDDB83SET[3:0]							W	Data for Matrix 83(DB83)
3Dh	08h	SCYCB84[1:0]	SDLYB84[1:0]	ILEDDB84SET[3:0]							W	Data for Matrix 84(DB84)
3Eh	08h	SCYCB85[1:0]	SDLYB85[1:0]	ILEDDB85SET[3:0]							W	Data for Matrix 85(DB85)
3Fh	08h	SCYCB86[1:0]	SDLYB86[1:0]	ILEDDB86SET[3:0]							W	Data for Matrix 86(DB86)
40h	08h	SCYCB90[1:0]	SDLYB90[1:0]	ILEDDB90SET[3:0]							W	Data for Matrix 90(DB90)
41h	08h	SCYCB91[1:0]	SDLYB91[1:0]	ILEDDB91SET[3:0]							W	Data for Matrix 91(DB91)
42h	08h	SCYCB92[1:0]	SDLYB92[1:0]	ILEDDB92SET[3:0]							W	Data for Matrix 92(DB92)
43h	08h	SCYCB93[1:0]	SDLYB93[1:0]	ILEDDB93SET[3:0]							W	Data for Matrix 93(DB93)
44h	08h	SCYCB94[1:0]	SDLYB94[1:0]	ILEDDB94SET[3:0]							W	Data for Matrix 94(DB94)
45h	08h	SCYCB95[1:0]	SDLYB95[1:0]	ILEDDB95SET[3:0]							W	Data for Matrix 95(DB95)
46h	08h	SCYCB96[1:0]	SDLYB96[1:0]	ILEDDB96SET[3:0]							W	Data for Matrix 96(DB96)
47h	08h	SCYCBA0[1:0]	SDLYBA0[1:0]	ILEDDBA0SET[3:0]							W	Data for Matrix A0(DBA0)
48h	08h	SCYCBA1[1:0]	SDLYBA1[1:0]	ILEDDBA1SET[3:0]							W	Data for Matrix A1(DBA1)
49h	08h	SCYCBA2[1:0]	SDLYBA2[1:0]	ILEDDBA2SET[3:0]							W	Data for Matrix A2(DBA2)
4Ah	08h	SCYCBA3[1:0]	SDLYBA3[1:0]	ILEDDBA3SET[3:0]							W	Data for Matrix A3(DBA3)
4Bh	08h	SCYCBA4[1:0]	SDLYBA4[1:0]	ILEDDBA4SET[3:0]							W	Data for Matrix A4(DBA4)
4Ch	08h	SCYCBA5[1:0]	SDLYBA5[1:0]	ILEDDBA5SET[3:0]							W	Data for Matrix A5(DBA5)
4Dh	08h	SCYCBA6[1:0]	SDLYBA6[1:0]	ILEDDBA6SET[3:0]							W	Data for Matrix A6(DBA6)
4Eh	08h	SCYCBB0[1:0]	SDLYBB0[1:0]	ILEDDBB0SET[3:0]							W	Data for Matrix B0(DBB0)
4Fh	08h	SCYCBB1[1:0]	SDLYBB1[1:0]	ILEDDBB1SET[3:0]							W	Data for Matrix B1(DBB1)
50h	08h	SCYCBB2[1:0]	SDLYBB2[1:0]	ILEDDBB2SET[3:0]							W	Data for Matrix B2(DBB2)
51h	08h	SCYCBB3[1:0]	SDLYBB3[1:0]	ILEDDBB3SET[3:0]							W	Data for Matrix B3(DBB3)
52h	08h	SCYCBB4[1:0]	SDLYBB4[1:0]	ILEDDBB4SET[3:0]							W	Data for Matrix B4(DBB4)
53h	08h	SCYCBB5[1:0]	SDLYBB5[1:0]	ILEDDBB5SET[3:0]							W	Data for Matrix B5(DBB5)
54h	08h	SCYCBB6[1:0]	SDLYBB6[1:0]	ILEDDBB6SET[3:0]							W	Data for Matrix B6(DBB6)
55h	08h	SCYCBC0[1:0]	SDLYBC0[1:0]	ILEDDBC0SET[3:0]							W	Data for Matrix C0(DBC0)
56h	08h	SCYCBC1[1:0]	SDLYBC1[1:0]	ILEDDBC1SET[3:0]							W	Data for Matrix C1(DBC1)
57h	08h	SCYCBC2[1:0]	SDLYBC2[1:0]	ILEDDBC2SET[3:0]							W	Data for Matrix C2(DBC2)
58h	08h	SCYCBC3[1:0]	SDLYBC3[1:0]	ILEDDBC3SET[3:0]							W	Data for Matrix C3(DBC3)
59h	08h	SCYCBC4[1:0]	SDLYBC4[1:0]	ILEDDBC4SET[3:0]						W	Data for Matrix C4(DBC4)	
5Ah	08h	SCYCBC5[1:0]	SDLYBC5[1:0]	ILEDDBC5SET[3:0]						W	Data for Matrix C5(DBC5)	
5Bh	08h	SCYCBC6[1:0]	SDLYBC6[1:0]	ILEDDBC6SET[3:0]						W	Data for Matrix C6(DBC6)	
5Ch	08h	SCYCBD0[1:0]	SDLYBD0[1:0]	ILEDDBD0SET[3:0]						W	Data for Matrix D0(DBD0)	
5Dh	08h	SCYCBD1[1:0]	SDLYBD1[1:0]	ILEDDBD1SET[3:0]						W	Data for Matrix D1(DBD1)	
5Eh	08h	SCYCBD2[1:0]	SDLYBD2[1:0]	ILEDDBD2SET[3:0]						W	Data for Matrix D2(DBD2)	
5Fh	08h	SCYCBD3[1:0]	SDLYBD3[1:0]	ILEDDBD3SET[3:0]						W	Data for Matrix D3(DBD3)	
60h	08h	SCYCBD4[1:0]	SDLYBD4[1:0]	ILEDDBD4SET[3:0]						W	Data for Matrix D4(DBD4)	

Address	default	D7	D6	D5	D4	D3	D2	D1	D0	Block	R/W	Remark
61h	08h	SCYCBD5[1:0]	SDLYBD5[1:0]	ILEDDB5SET[3:0]						MATRIX Data	W	Data for Matrix D5(DBD5)
62h	08h	SCYCBD6[1:0]	SDLYBD6[1:0]	ILEDDB6SET[3:0]							W	Data for Matrix D6(DBD6)
63h	08h	SCYCBE0[1:0]	SDLYBE0[1:0]	ILEDBE0SET[3:0]							W	Data for Matrix E0(DBE0)
64h	08h	SCYCBE1[1:0]	SDLYBE1[1:0]	ILEDBE1SET[3:0]							W	Data for Matrix E1(DBE1)
65h	08h	SCYCBE2[1:0]	SDLYBE2[1:0]	ILEDBE2SET[3:0]							W	Data for Matrix E2(DBE2)
66h	08h	SCYCBE3[1:0]	SDLYBE3[1:0]	ILEDBE3SET[3:0]							W	Data for Matrix E3(DBE3)
67h	08h	SCYCBE4[1:0]	SDLYBE4[1:0]	ILEDBE4SET[3:0]							W	Data for Matrix E4(DBE4)
68h	08h	SCYCBE5[1:0]	SDLYBE5[1:0]	ILEDBE5SET[3:0]							W	Data for Matrix E5(DBE5)
69h	08h	SCYCBE6[1:0]	SDLYBE6[1:0]	ILEDBE6SET[3:0]							W	Data for Matrix E6(DBE6)
6Ah	08h	SCYCBF0[1:0]	SDLYBF0[1:0]	ILEDDBF0SET[3:0]							W	Data for Matrix F0(DBF0)
6Bh	08h	SCYCBF1[1:0]	SDLYBF1[1:0]	ILEDDBF1SET[3:0]							W	Data for Matrix F1(DBF1)
6Ch	08h	SCYCBF2[1:0]	SDLYBF2[1:0]	ILEDDBF2SET[3:0]							W	Data for Matrix F2(DBF2)
6Dh	08h	SCYCBF3[1:0]	SDLYBF3[1:0]	ILEDDBF3SET[3:0]							W	Data for Matrix F3(DBF3)
6Eh	08h	SCYCBF4[1:0]	SDLYBF4[1:0]	ILEDDBF4SET[3:0]							W	Data for Matrix F4(DBF4)
6Fh	08h	SCYCBF5[1:0]	SDLYBF5[1:0]	ILEDDBF5SET[3:0]							W	Data for Matrix F5(DBF5)
70h	08h	SCYCBF6[1:0]	SDLYBF6[1:0]	ILEDDBF6SET[3:0]							W	Data for Matrix F6(DBF6)
71h	08h	SCYCBG0[1:0]	SDLYBG0[1:0]	ILEDDBG0SET[3:0]							W	Data for Matrix G0(DBG0)
72h	08h	SCYCBG1[1:0]	SDLYBG1[1:0]	ILEDDBG1SET[3:0]							W	Data for Matrix G1(DBG1)
73h	08h	SCYCBG2[1:0]	SDLYBG2[1:0]	ILEDDBG2SET[3:0]							W	Data for Matrix G2(DBG2)
74h	08h	SCYCBG3[1:0]	SDLYBG3[1:0]	ILEDDBG3SET[3:0]							W	Data for Matrix G3(DBG3)
75h	08h	SCYCBG4[1:0]	SDLYBG4[1:0]	ILEDDBG4SET[3:0]						W	Data for Matrix G4(DBG4)	
76h	08h	SCYCBG5[1:0]	SDLYBG5[1:0]	ILEDDBG5SET[3:0]						W	Data for Matrix G5(DBG5)	
77h	08h	SCYCBG6[1:0]	SDLYBG6[1:0]	ILEDDBG6SET[3:0]						W	Data for Matrix G6(DBG6)	

●Register Map

Address 00H < Software Reset >

Address (Index)	R/W	Bit7	Bit6	Bit5	Bit4	Bit3	Bit2	Bit1	Bit0
00H	W	-	-	-	-	-	-	-	SFTRST
Initial value	00H	-	-	-	-	-	-	-	0

Bit 0 : SFTRST Software Reset

“0” : Reset cancel

“1” : Reset(All register initializing)

*SFTRST register return to 0 automatically.

Address 01H <OSC control >

Address (Index)	R/W	Bit7	Bit6	Bit5	Bit4	Bit3	Bit2	Bit1	Bit0
01H	W	-	-	-	-	OSCEN	-	-	-
Initial value	00H	0	0	0	0	0	0	0	0

Bit 3 : OSCEN OSC block ON/OFF control

“0” : OFF(Initial)

“1” : ON

This register should not change into “1 → 0” at the time of START (30h, D0) register = “1” setup (under lighting operation).

This register must be set to “0” after LED putting out lights (“START register = 0”), and please surely stop an internal oscillation circuit.

Address 11H < LED1-6 Enable >

Address (Index)	R/W	Bit7	Bit6	Bit5	Bit4	Bit3	Bit2	Bit1	Bit0
11H	W	-	-	LED6ON	LED5ON	LED4ON	LED3ON	LED2ON	LED1ON
Initial value	00H	0	0	0	0	0	0	0	0

Bit 0 : LED1ON LED1 ON/OFF setting

“0” : LED1 OFF(initial)

“1” : LED1 ON

Bit 1 : LED2ON LED2 ON/OFF setting

“0” : LED2 OFF(initial)

“1” : LED2 ON

Bit 2 : LED3ON LED3 ON/OFF setting

“0” : LED3 OFF(initial)

“1” : LED3 ON

Bit 3 : LED4ON LED4 ON/OFF setting

“0” : LED4 OFF(initial)

“1” : LED4 ON

Bit 4 : LED5ON LED5 ON/OFF setting

“0” : LED5 OFF(initial)

“1” : LED5 ON

Bit 5 : LED6ON LED6 ON/OFF setting

“0” : LED6 OFF(initial)

“1” : LED6 ON

* Current setting follows ILEDAXXSET[3:0] or ILEDBXXSET[3:0] register.

Address 12H < LED7-12 Enable >

Address (Index)	R/W	Bit7	Bit6	Bit5	Bit4	Bit3	Bit2	Bit1	Bit0
12H	W	-	-	LED12ON	LED11ON	LED10ON	LED9ON	LED8ON	LED7ON
Initial value	00H	0	0	0	0	0	0	0	0

Bit 0 : LED7ON LED7 ON/OFF setting

“0” : LED7 OFF(initial)

“1” : LED7 ON

Bit 1 : LED8ON LED8 ON/OFF setting

“0” : LED8 OFF(initial)

“1” : LED8 ON

Bit 2 : LED9ON LED9 ON/OFF setting

“0” : LED9 OFF(initial)

“1” : LED9 ON

Bit 3 : LED10ON LED10 ON/OFF setting

“0” : LED10 OFF(initial)

“1” : LED10 ON

Bit 4 : LED11ON LED11 ON/OFF setting

“0” : LED11 OFF(initial)

“1” : LED11 ON

Bit 5 : LED12ON LED12 ON/OFF setting

“0” : LED12 OFF(initial)

“1” : LED12 ON

* Current setting follows ILEDAXXSET[3:0] or ILEDBXXSET[3:0] register.

Address 13H < LED13-17 Enable >

Address (Index)	R/W	Bit7	Bit6	Bit5	Bit4	Bit3	Bit2	Bit1	Bit0
13H	W	-	-	-	LED17ON	LED16ON	LED15ON	LED14ON	LED13ON
Initial value	00H	0	0	0	0	0	0	0	0

Bit 0 : LED13ON LED13 ON/OFF setting

“0” : LED13 OFF(initial)

“1” : LED13 ON

Bit 1 : LED14ON LED14 ON/OFF setting

“0” : LED14 OFF(initial)

“1” : LED14 ON

Bit 2 : LED15ON LED15 ON/OFF setting

“0” : LED15 OFF(initial)

“1” : LED15 ON

Bit 3 : LED16ON LED16 ON/OFF setting

“0” : LED16 OFF(initial)

“1” : LED16 ON

Bit 4 : LED17ON LED17 ON/OFF setting

“0” : LED17 OFF(initial)

“1” : LED17 ON

* Current setting follows ILEDAXXSET[3:0] or ILEDBXXSET[3:0] register.

Address 17H < LED14-17 TDMA Enable >

Address (Index)	R/W	Bit7	Bit6	Bit5	Bit4	Bit3	Bit2	Bit1	Bit0
17H	W	-	-	-	-	LED17 TDMAON	LED16 TDMAON	LED15 TDMAON	LED14 TDMAON
Initial value	0FH	0	0	0	0	1	1	1	1

Bit 0 : LED14TDMAON TDMA control Enable setting for LED14

- “0” : TDMA control for LED14 is OFF
LED current value is set by ILEDAD0SET[3:0] or ILEDBD0SET[3:0] (it changes by the OAB [7Fh, D1] register). It becomes the setting value of ILEDAD0SET [3:0] until scroll reset is carried out by SCLRST (2Eh, D0) register =“1” after a scroll stop, under scrolling.
- “1” : TDMA control for LED14 is ON (initial)

Bit 1 : LED15TDMAON TDMA control Enable setting for LED15

- “0” : TDMA control for LED15 is OFF
LED current value is set by ILEDAE0SET[3:0] or ILEDBE0SET[3:0]. (it changes by the OAB [7Fh, D1] register). It becomes the setting value of ILEDAE0SET [3:0] until scroll reset is carried out by SCLRST (2Eh, D0) register =“1” after a scroll stop, under scrolling.
- “1” : TDMA control for LED15 is ON (initial)

Bit 2 : LED16TDMAON TDMA control Enable setting for LED16

- “0” : TDMA control for LED16 is OFF
LED current value is set by ILEDAF0SET[3:0] or ILEDBF0SET[3:0]. (it changes by the OAB [7Fh, D1] register). It becomes the setting value of ILEDAF0SET [3:0] until scroll reset is carried out by SCLRST (2Eh, D0) register =“1” after a scroll stop, under scrolling.
- “1” : TDMA control for LED16 is ON (initial)

Bit 3 : LED17TDMAON TDMA control Enable setting for LED17

- “0” : TDMA control for LED17 is OFF
LED current value is set by ILEDAG0SET[3:0] or ILEDBG0SET[3:0]. (it changes by the OAB [7Fh, D1] register). It becomes the setting value of ILEDAG0SET [3:0] until scroll reset is carried out by SCLRST (2Eh, D0) register =“1” after a scroll stop, under scrolling.
- “1” : TDMA control for LED17 is ON (initial)

- * The setting change at the time of START (30h, D0) register =“1” of this register is prohibition.
- * LED, which is set to “0”(TDMA off), is put on and not controlled by SYNC terminal however SYNCON (21h,D2) register is set to “1”.
- * Please use this register only in the following combination.

LED17TDMAON	LED16TDMAON	LED15TDMAON	LED14TDMAON
0	0	0	0
0	0	0	1
0	0	1	1
0	1	1	1
1	1	1	1
Except the above: Prohibition			

Address 20H < LED1-17 PWM setting >

Address (Index)	R/W	Bit7	Bit6	Bit5	Bit4	Bit3	Bit2	Bit1	Bit0
20H	W	-	-	PWMSET [5:0]					
Initial value	00H	0	0	0	0	0	0	0	0

Bit 5-0 : PWMSET[5:0] LED1-17 PWM DUTY setting

“000000” : 0/63=0%(initial)

“000001” : 1/63=1.59%

:

:

“100000” : 32/63=50.8%

:

:

“111110” : 62/63=98.4%

“111111” : 63/63=100%

*Please refer to Description of operation, chapter 2

Address 21H < SYNC operation control >

Address (Index)	R/W	Bit7	Bit6	Bit5	Bit4	Bit3	Bit2	Bit1	Bit0
21H	W	-	-	-	-	SYNCACT	SYNCON	CLKOUT	CLKIN
Initial value	00H	0	0	0	0	0	0	0	0

Bit 0 : CLKIN Selection CLK for PWM control

“0” : Internal OSC (initial)

“1” : External CLK input

Bit 1 : CLKOUT Output CLK enable

“0” : CLK is not output (initial)

“1” : Output selected CLK from CLKOUT pin

As for CLKIN & CLKOUT, setting change is forbidden under OSCEN (01h, D3) register =“1” and also under clock input to CLKIN terminal.

Bit 2 : SYNCON SYNC operation enable

“0” : Disable SYNC operation (initial)

“1” : SYNC pin control LED driver ON/OFF

Bit 3 : SYNCACT SYNC operation setting

“0” : When SYNC pin is “L”, LED drivers are ON (initial)

“1” : When SYNC pin is “H”, LED drivers are ON

Address 2DH < PWM, SLOPE, SCROLL ON/OFF setting >

Address (Index)	R/W	Bit7	Bit6	Bit5	Bit4	Bit3	Bit2	Bit1	Bit0
2DH	W	-	-	-	-	-	PWMEN	SLPEN	SCLEN
Initial value	00H	0	0	0	0	0	0	0	0

Bit 0 : SCLEN SCROLL operation ON/OFF setting

“0” : SCROL operation OFF(initial value)

“1” : SCROL operation ON

Bit 1 : SLPEN SLOPE operation ON/OFF setting

“0” : SLOPE operation OFF(initial value)

“1” : SLOPE operation ON

Bit 2 : PWMEN PWM control at LED1-17 ON/OFF setting

“0” : PWM operation is invalid(initial value)

“1” : PWM operation is valid

*Please refer to Description of operation, chapter 2

Address 2EH < Reset scroll >

Address (Index)	R/W	Bit7	Bit6	Bit5	Bit4	Bit3	Bit2	Bit1	Bit0
2EH	W	-	-	-	-	-	-	-	SCLRST
Initial value	00H	0	0	0	0	0	0	0	0

Bit 0 : SCLRST Reset scroll state

“0” : Not reset(initial value)

“1” : Reset scroll state

* SCLRST register return to 0 automatically

Address 2FH < Scroll setting >

Address (Index)	R/W	Bit7	Bit6	Bit5	Bit4	Bit3	Bit2	Bit1	Bit0
2FH	W	-	SCLSPEED [2:0]			UP	DOWN	RIGHT	LEFT
Initial value	00H	0	0	0	0	0	0	0	0

Bit 0 : LEFT Setting the scroll operation from right to left

“0” : Scroll operation OFF (initial value)

“1” : Scroll operation ON

Bit 1 : RIGHT Setting the scroll operation from left to right

“0” : Scroll operation OFF (initial value)

“1” : Scroll operation ON

*When LEFT operation is valid, RIGHT setting is ignored.

Bit 2 : DOWN Setting the scroll operation from top to bottom

“0” : Scroll operation OFF (initial value)

“1” : Scroll operation ON

Bit 3 : UP Setting the scroll operation from bottom to top

“0” : Scroll operation OFF (initial value)

“1” : Scroll operation ON

*When UP operation is valid, DOWN setting is ignored.

Bit 6-4 : SCLSPEED[2:0] Setting the scroll speed

“000” : 0.1s (initial value)

“001” : 0.2s

“010” : 0.3s

“011” : 0.4s

“100” : 0.5s

“101” : 0.6s

“110” : 0.7s

“111” : 0.8s

*Setting time is based on OSC frequency, and the above-mentioned shows the value under Typ (1.2MHz).

*Setting time changes on CLKIN terminal input frequency at the external clock operation.

Example)

CLKIN input frequency=1.2MHz→“000”: 0.1sec (it is the same as the above)

CLKIN input frequency=2.4MHz→“000”: 0.05sec

CLKIN input frequency= 0.6MHz→“000”: 0.2sec

Address 30H < LED Matrix control >

Address (Index)	R/W	Bit7	Bit6	Bit5	Bit4	Bit3	Bit2	Bit1	Bit0
30H	W	-	-	-	-	-	-	-	START
Initial value	00H	0	0	0	0	0	0	0	0

Bit 0 : START Lighting/turning off bit of MATRIX LED(LED1-17)

“0” : MATRIX LED(LED1-17) Lights out

“1” : MATRIX LED(LED1-17) Lighting, SLOPE and SCROLL sequence start

Address 31H < Matrix data clear >

Address (Index)	R/W	Bit7	Bit6	Bit5	Bit4	Bit3	Bit2	Bit1	Bit0
31H	W	-	-	-	-	-	-	CLRB	CLRA
Initial value	00H	0	0	0	0	0	0	0	0

Bit 0 : CLRA Reset A-pattern register

“0” : A-pattern register is not reset and writable(initial value)

“1” : A-pattern register is reset

Bit 0 : CLRB Reset B-pattern register

“0” : B-pattern register is not reset and writable(initial value)

“1” : B-pattern register is reset

*CLRA and CLRB register return to 0 automatically.

Address 7FH < Register map change >

Address (Index)	R/W	Bit7	Bit6	Bit5	Bit4	Bit3	Bit2	Bit1	Bit0
7FH	W	-	-	-	-	-	IAB	OAB	RMCG
Initial value	00H	0	0	0	0	0	0	0	0

Bit 0 : RMCG Change register map

“0” : Control register is selected(initial value)

“1” : A-pattern register or B-pattern register is selected

Bit 1 : OAB Select register to output for matrix

“0” : A-pattern register is selected(initial value)

“1” : B-pattern register is selected

Bit 2 : IAB Select register to write matrix data

“0” : A-pattern register is selected(initial value)

“1” : B-pattern register is selected

* It is prohibition to write A-pattern data when A-pattern is displaying (OAB=0).

Also, it is prohibition to write B-pattern data when B-pattern is displaying (OAB=1).

Change of a display picture should be done by change of the OAB register, after updating of a non-displaying pattern register.

Address 01H-77H < A-pattern register data >

Address (Index)	R/W	Bit7	Bit6	Bit5	Bit4	Bit3	Bit2	Bit1	Bit0
01-77H	W	SCYCAXX [1:0]		SDLYAXX [1:0]		ILEDAXXSET [3:0]			
Initial value	08H	0	0	0	0	1	0	0	0

Bit 3-0 : ILEDAXXSET[3:0] LED output current setting for A-pattern matrix data

"0000" : 0.00mA
 "0001" : 1.33mA
 "0010" : 2.67mA
 "0011" : 4.00mA
 "0100" : 5.33mA
 "0101" : 6.67mA
 "0110" : 8.00mA
 "0111" : 9.33mA
 "1000" : 10.67mA(initial value)
 "1001" : 12.00mA
 "1010" : 13.33mA
 "1011" : 14.67mA
 "1100" : 16.00mA
 "1101" : 17.33mA
 "1110" : 18.67mA
 "1111" : 20.00mA

Bit 5-4 : SDLYAXX[1:0] SLOPE delay setting for A-pattern matrix

"00" : No delay(initial value)
 "01" : 1/4x(slope cycle time)
 "10" : 1/2x(slope cycle time)
 "11" : 3/4x(slope cycle time)

Bit 7-6 : SCYCAXX[1:0] SLOPE cycle time setting for A-pattern matrix

"00" : No SLOPE control(initial value)
 "01" : 1s(=slope cycle time)
 "10" : 2s(=slope cycle time)
 "11" : 3s(=slope cycle time)

* The "XX" shows the matrix number from "00" to "G6". Please refer 7x17 LED Matrix coordinate.

*Setting time is based on OSC frequency, and the above-mentioned shows the value under Typ (1.2MHz).

*Setting time changes on CLKIN terminal input frequency at the external clock operation.

Example)

CLKIN input frequency=1.2MHz→"01": Slope cycle =1sec (it is the same as the above)

CLKIN input frequency=2.4MHz→"01": Slope cycle =0.5sec

CLKIN input frequency=0.6MHz→"01": Slope cycle =2sec

Address 01H-77H < B-pattern register data >

Address (Index)	R/W	Bit7	Bit6	Bit5	Bit4	Bit3	Bit2	Bit1	Bit0
01-77H	W	SCYCBXX[1:0]		SDLYBXX[1:0]		ILEDDBXXSET[3:0]			
Initial value	08H	0	0	0	0	1	0	0	0

Bit 3-0 :ILEDDBXXSET[3:0] LED output current setting for B-pattern matrix data

"0000" : 0.00mA
 "0001" : 1.33mA
 "0010" : 2.67mA
 "0011" : 4.00mA
 "0100" : 5.33mA
 "0101" : 6.67mA
 "0110" : 8.00mA
 "0111" : 9.33mA
 "1000" : 10.67mA(initial value)
 "1001" : 12.00mA
 "1010" : 13.33mA
 "1011" : 14.67mA
 "1100" : 16.00mA
 "1101" : 17.33mA
 "1110" : 18.67mA
 "1111" : 20.00mA

Bit 5-4 :SDLYBXX[1:0] SLOPE delay setting for B-pattern matrix

"00" : No delay(initial value)
 "01" : 1/4x(slope cycle time)
 "10" : 1/2x(slope cycle time)
 "11" : 3/4x(slope cycle time)

Bit 7-6 :SCYCBXX[1:0] SLOPE cycle time setting for B-pattern matrix

"00" : No SLOPE control(initial value)
 "01" : 1s(=slope cycle time)
 "10" : 2s(=slope cycle time)
 "11" : 3s(=slope cycle time)

* The "XX" shows the matrix number from "00" to "G6". Please refer 7x17 LED Matrix coordinate.

*Setting time is based on OSC frequency, and the above-mentioned shows the value under Typ (1.2MHz).

*Setting time changes on CLKIN terminal input frequency at the external clock operation.

Example)

CLKIN input frequency=1.2MHz→"01": Slope cycle =1sec (it is the same as the above)

CLKIN input frequency=2.4MHz→"01": Slope cycle =0.5sec

CLKIN input frequency=0.6MHz→"01": Slope cycle =2sec

●Description of operation

1. LED Matrix

1-1. Lighting method of dot Matrix

It can control 7 x 17 Matrix.

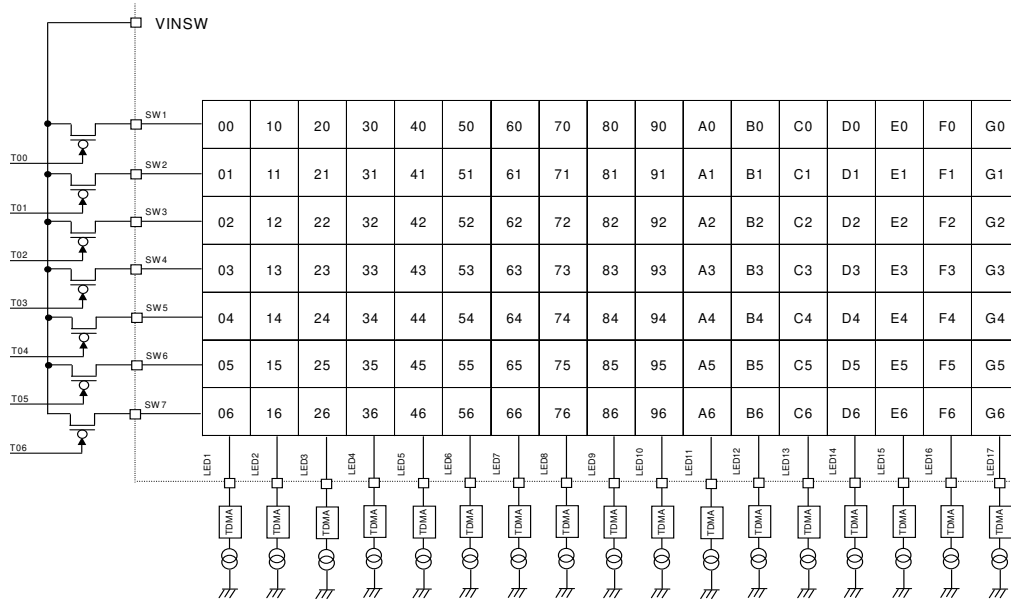

Fig.10 7 x 17 LED Matrix coordinate

The SW1 – SW7 is turned on by serial. LED is driven one by one within the ON period.

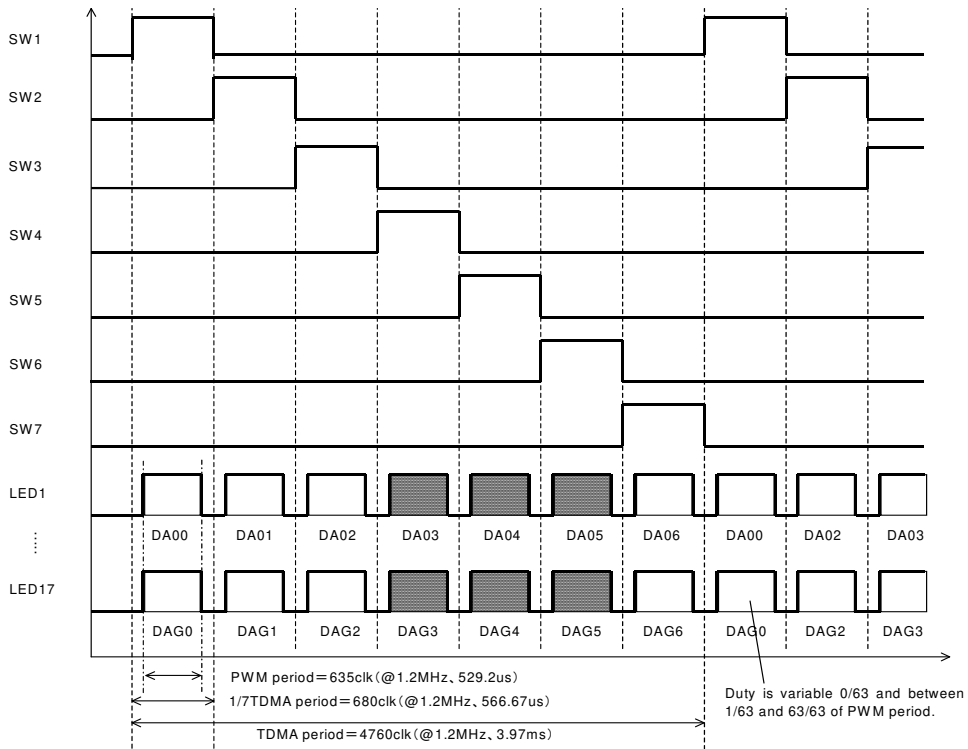

Fig.11 SW timing

1-2. LED lighting example

The firefly lighting example.

The following command set is the example of LED matrix firefly lighting.
It can control the turn on/off time in detail by SLOPE setting registers.

1)	7FH	00000000	Select control register
2)	21H	00000000	Select internal OSC for CLK
3)	01H	00001000	Start OSC
4)	11H	00111111	Set LED1-6 enable
5)	12H	00111111	Set LED7-12 enable
6)	13H	00011111	Set LED13-17 enable
7)	20H	00111111	Set Max Duty at Slope
8)	1FH	00000001	Select A-pattern or B-pattern register, Select A-pattern register to write matrix data
9)	01-77H	xxxxxxx	Write A-pattern data
10)	7FH	00000000	Select control register, Select A-pattern register to output for matrix
11)	2DH	00000100	Set SLOPE control enable
12)	30H	00000001	Start SLOPE sequence
13)	30H	00000000	Lights out

2. LED Driver Current, SLOPE and SCROLL Sequence Control

2-1. LED driver current control

It can be controlled PWM Duty and DC current for LED driver current.

	Item	Control object	Control detail	Setting Registers	
				Name *	Bits
(A)	PWM Duty	Whole matrix	0/63~63/63 (64 step)	PWMSET	6
(B)	DC current	Each matrix dot	0~20.00mA (16 step)	ILEDAXXSET ILEDXXSET	4

* The "XX" shows the matrix number from "00" to "G6". Please refer 7x17 LED Matrix coordinate.

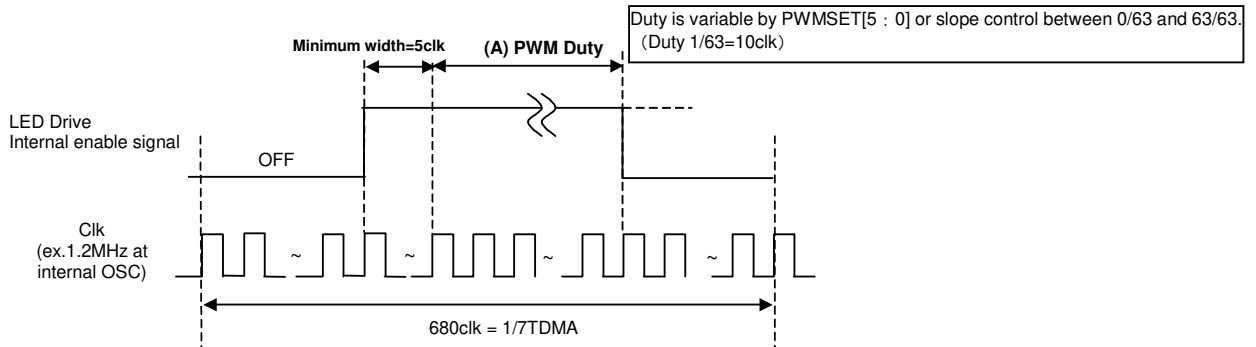

Fig.12 LED output current timing and PWM cycle

635clk of PWM period is set in the 1/7 TDMA period (680clk).
 PWM is operated 63 steps of 10clk. TDMA period is 3.97s (@1.2MHz).
 Moreover, it has the starting waiting time of a constant current driver by 5clk(s).
 PWM"H" time turns into ON time after waiting 5 clk.
 (However, LED driver is set "OFF" compulsorily at PWM=0% setting.)

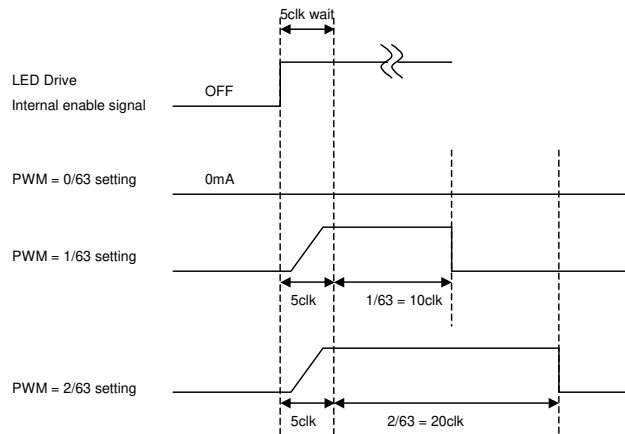

Fig.13 LED output current timing and a PWM cycle

2-2. SLOPE control

It can be controlled Delay and SLOPE cycle time for LED driver current.

	Item	Control object	Control detail	Setting Registers	
				Name *	Bits
(A)	Delay	Each matrix dot	0~3/4 x slope cycle time (4 step)	SDLYAXX SDLYBXX	2
(B)	SLOPE cycle time	Each matrix dot	0~3sec (4 step)	SCYCAXX SCYCBXX	2

* The "XX" shows the matrix number from "00" to "G6". Please refer 7x17 LED Matrix coordinate.

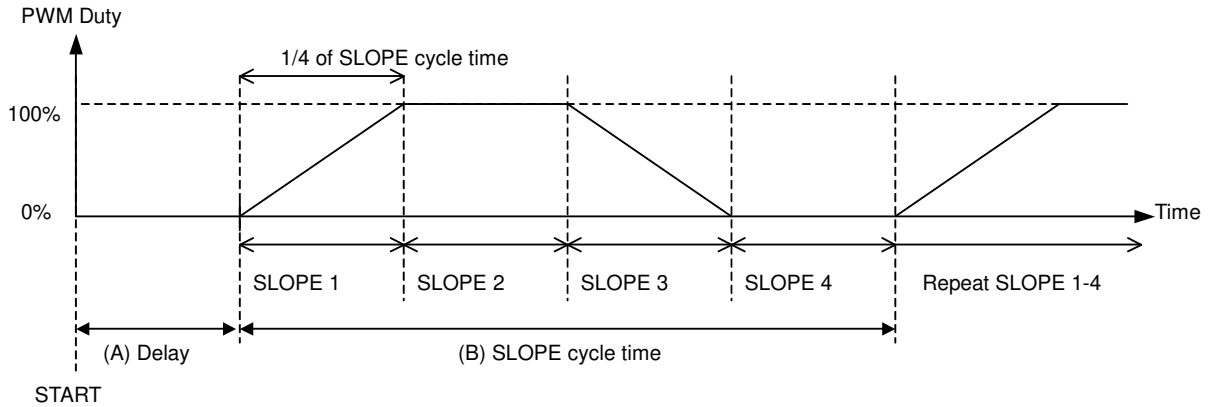

Fig.14 SLOPE operation

When SLPEN="1" and PWMEN=SCLLEN="0", SLOPE operation starts (like upper figure).

After "Delay" time SLOPE1-4 operation repeat.

Each period of SLOPE1-4 is 1/4 of SLOPE cycle time.

- SLOPE 1: 1 step is 1/63 of SLOPE 1 period. Duty is increased 1.587% step by step.
- SLOPE 2: Duty is fixed at 100%.
- SLOPE 3: 1 step is 1/63 of SLOPE 1 period. Duty is decreased 1.587% step by step.
- SLOPE 4: Duty is fixed at 0%.

2-3. SCROLL control

2-3-1 Normal operation

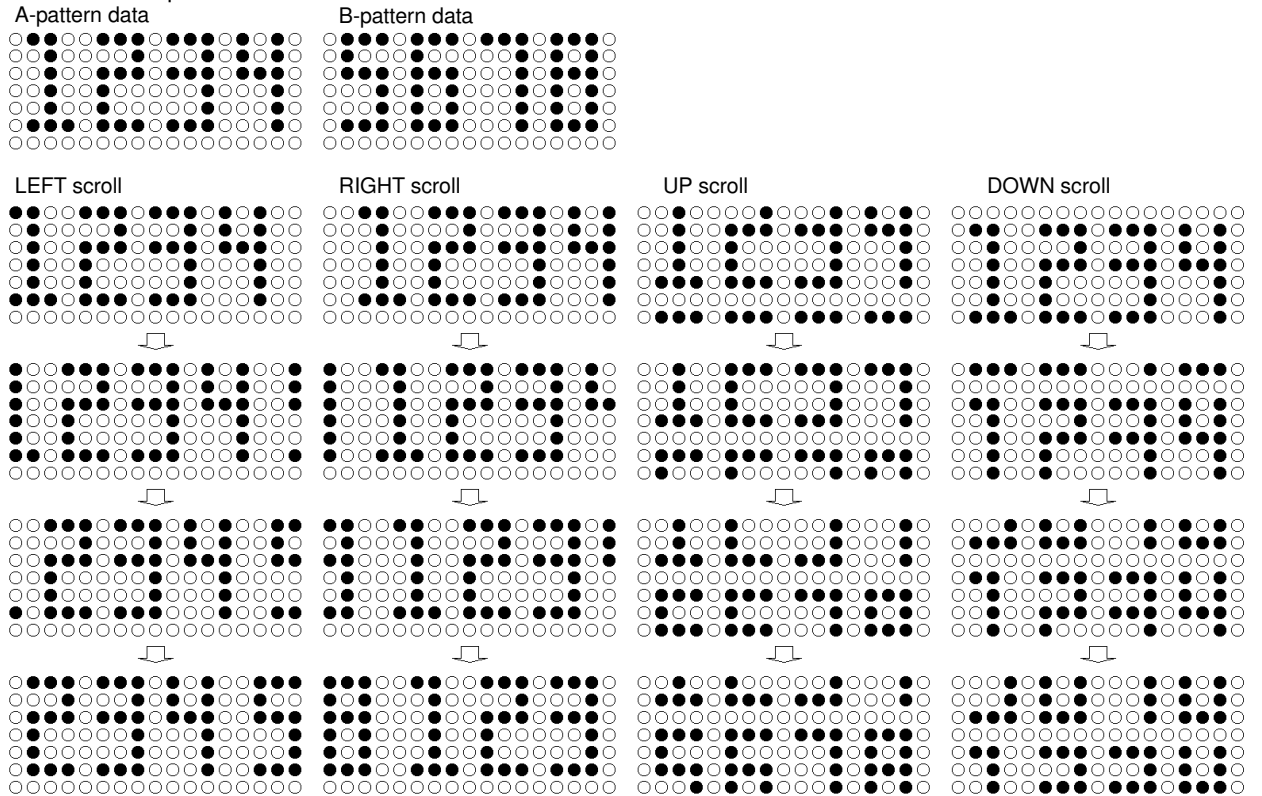

2-3-2 Operation at TDMA off setting (The following is the matrix arrangement which has not assigned LED16-LED17.)

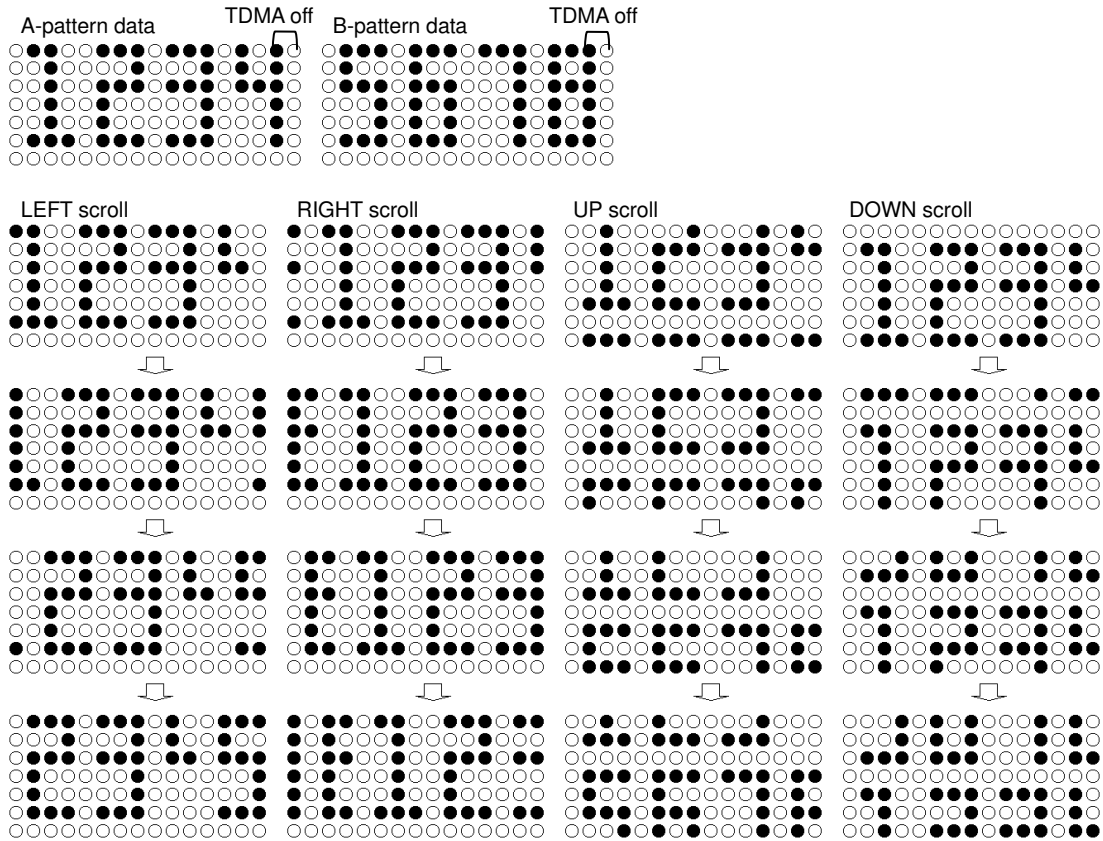

2-4. Relation of PWM, SLOPE and SCROLL control

Register of condition and enable

	PWM	SLOPE	SCROLL
Condition	PWMSET [5:0]	SCYCXXX [1:0] SDLYXXX [1:0]	SCLSPEED [2:0] UP/DOWN/RIGHT/LEFT
Enable	PWMEN	SLPEN	SCLEN

Combination of command

Operation	PWMEN	SLPEN	SCLEN
1	OFF	OFF	OFF
2	ON	OFF	OFF
3	OFF	ON	OFF
4	ON	ON	OFF
5	OFF	OFF	ON
Do not use this combination	ON	OFF	ON
	OFF	ON	ON
	ON	ON	ON

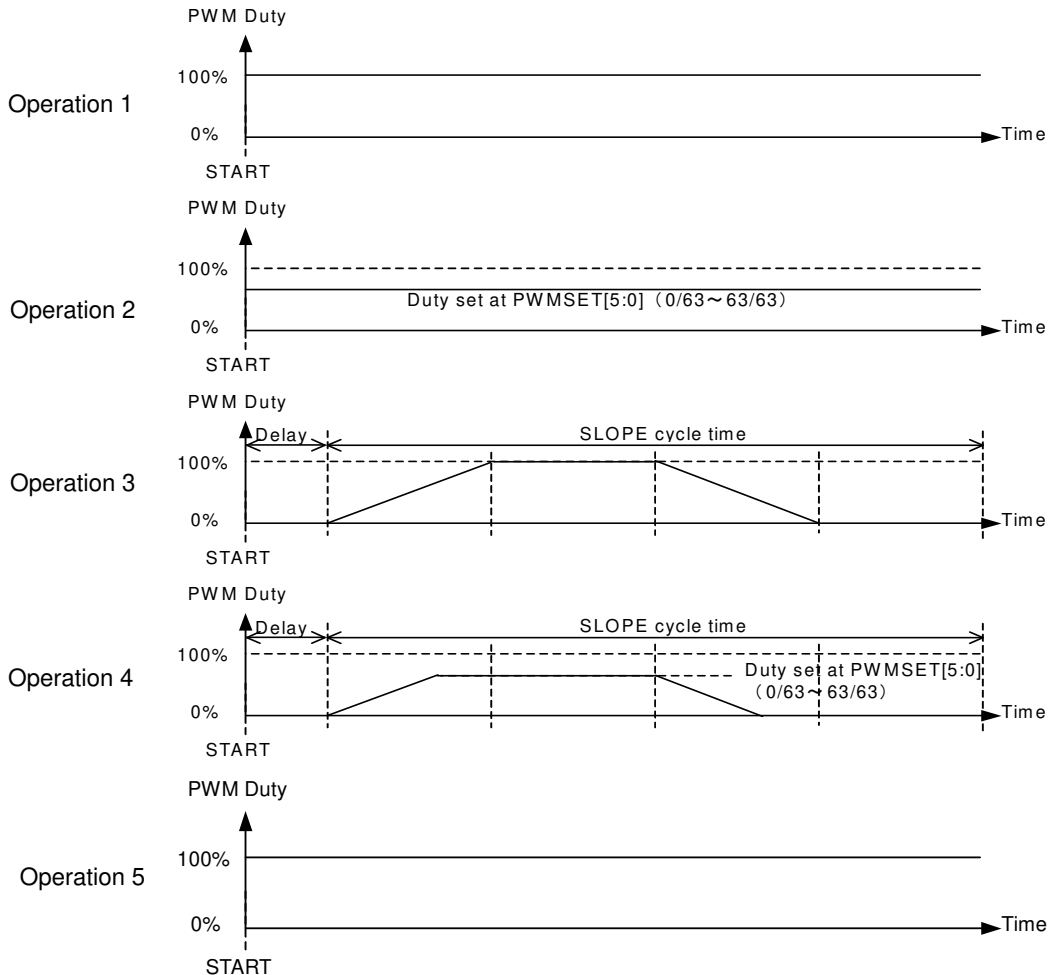

3. Power up sequence

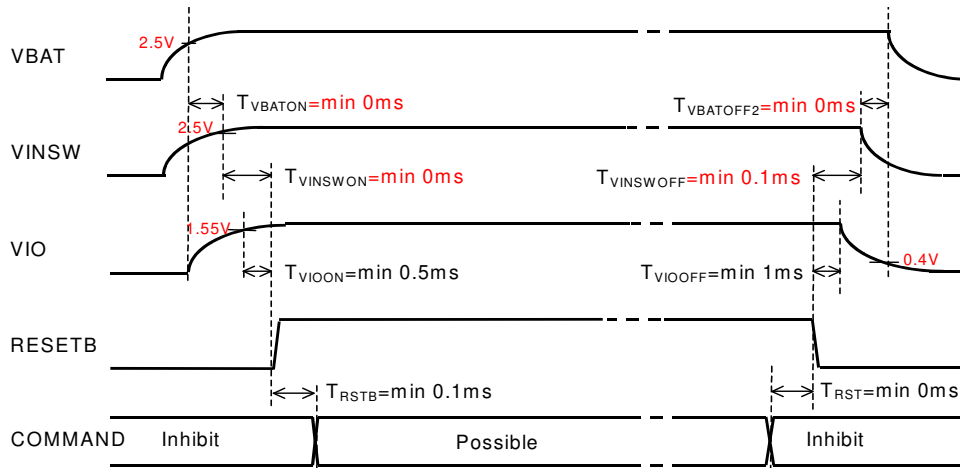

Fig.15 Power up sequence

Please take sufficient wait time for each Power/Control signal.

However, if $V_{BAT} < 2.1\text{V}(\text{typ})$ or $T_a > T_{TSD}(\text{typ}:175^\circ\text{C})$, the command input is not effective because of the protection operation. Please rise VIO voltage after VBAT voltage raise more 2.5V, and fall VIO voltage after VBAT voltage fall less 0.4V.

4. Reset

There are two kinds of reset, software reset and hardware reset

(1) Software reset

- All the registers are initialized by SFTRST="1".
- SFTRST is an automatically returned to "0". (Auto Return 0).

(2) Hardware reset

- It shifts to hardware reset by changing RESETB pin "H" → "L".
- The condition of all the registers under hardware reset pin is returned to the Initial Value and it stops accepting all address.all LED driver turn off.
- It's possible to release from a state of hardware reset by changing RESETB pin "L" → "H". RESETB pin has delay circuit. It doesn't recognize as hardware reset in "L" period under 5 μs .

5. Thermal shutdown

A thermal shutdown function is effective at all blocks of those other than VREF. Return to the state before detection automatically at the time of release.

The thermal shutdown function is detection temperature that it works is about 175 $^\circ\text{C}$

Detection temperature has a hysteresis, and detection release temperature is about 150 $^\circ\text{C}$ (Design reference value)

6. UVLO Function (VBAT Voltage Low-Voltage Detection)

UVLO function is effective at all blocks of those other than VREF, and when detected, those blocks function is stopped. Return to the state before detection automatically at the time of release.

7. I/O

When the RESETB pin is Low, the input buffers (SDA and SCL) are disabling for the Low consumption power.

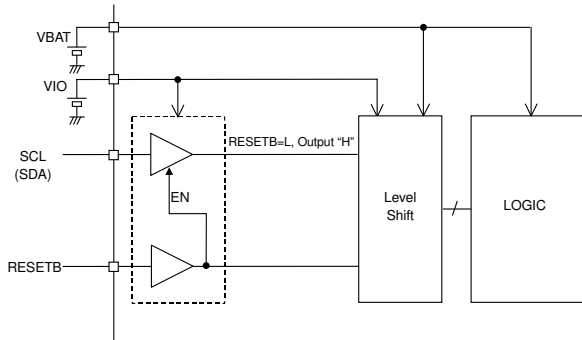

Fig.16 Input disabling by RESETB

8. Standard Clock Input and Output

It is possible to carry out synchronous operation of two or more ICs using the input-and-output function of a standard clock.

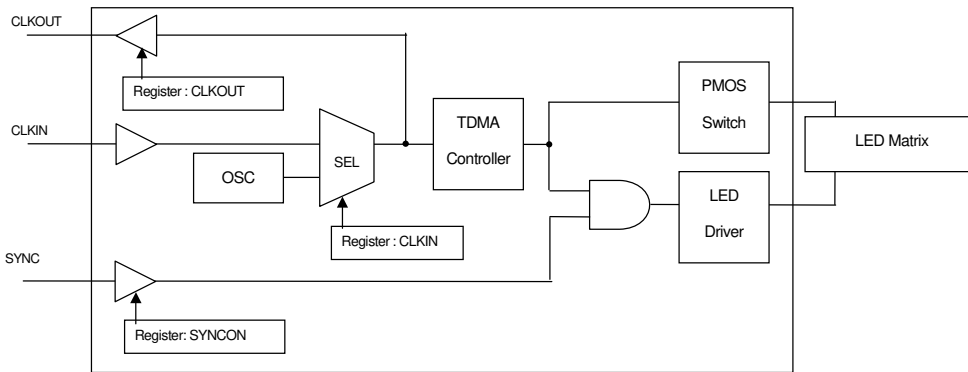

Fig.17 I/O part equivalent circuit diagram

- When a clock is supplied from the exterior
Inputting an external standard clock from CLKIN and setting register CLKIN=1, IC operates with the clock inputted from CLKIN as a standard clock.
- When the built-in oscillation circuit of one IC is used
When a clock cannot be supplied from the exterior, it is possible to synchronize between ICs by the connection as the following figure.

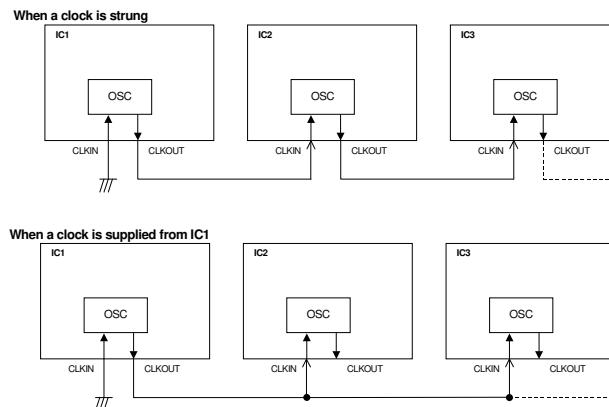

Fig.18 It is an example of application for the usage of two or more.

9. External ON/OFF Synchronization (SYNC Terminal)
 Lighting of LED that synchronized with the external signal is possible.
 By setting H/L of SYNC terminal, LED drivers output is set ON/OFF.
 It's asynchronous operation with the internal TDMA control.

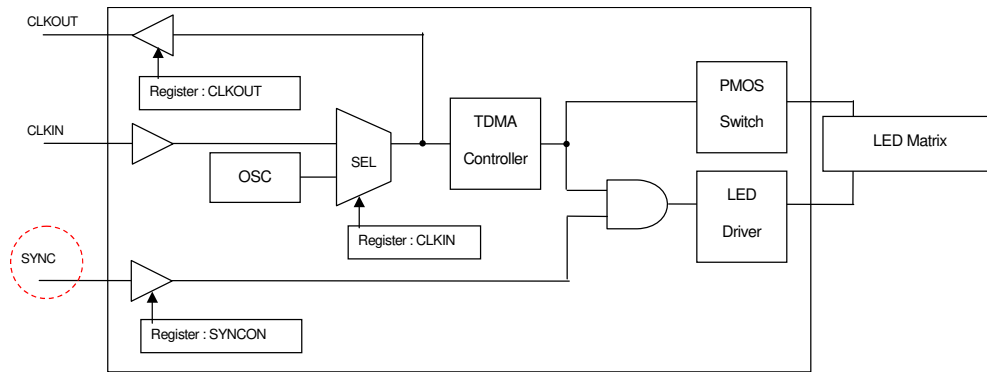

Fig.19 I/O part equivalent circuit diagram

10. About terminal processing of the function which is not used
 Please set up a test terminal and the unused terminal as the following table.
 Especially, if an input terminal is not fixed, it may occur the unstable state of a device and the unexpected internal current.

Terminal name	Processing	Reason
SYNC	GND Short	The input terminal
CLKIN	GND Short	The input terminal
CLKOUT	Open	The output terminal
TEST1 – TEST5	GND Short	The input terminal for a test
TESTO	Open	The output terminal for a test
DO	Open	The output terminal
LED Terminal	GND Short	In order to avoid an unfixed state. (A register setup in connection with LED terminal that is not used is forbidden.)
SW Terminal	VINSW Short	In order to avoid an unfixed state. (A register setup in connection with SW terminal that is not used is forbidden.)

11.About the prevention of a little lighting LED from SW pin's parasitic capacitance

The LED little light up by SW pin's parastic capacitance maybe that it depends on LED's sensitivity of current though LED current setting is 0mA.

It improves this problem that the register (reference value: 1MΩ) is set up between SW pin and GND pin.

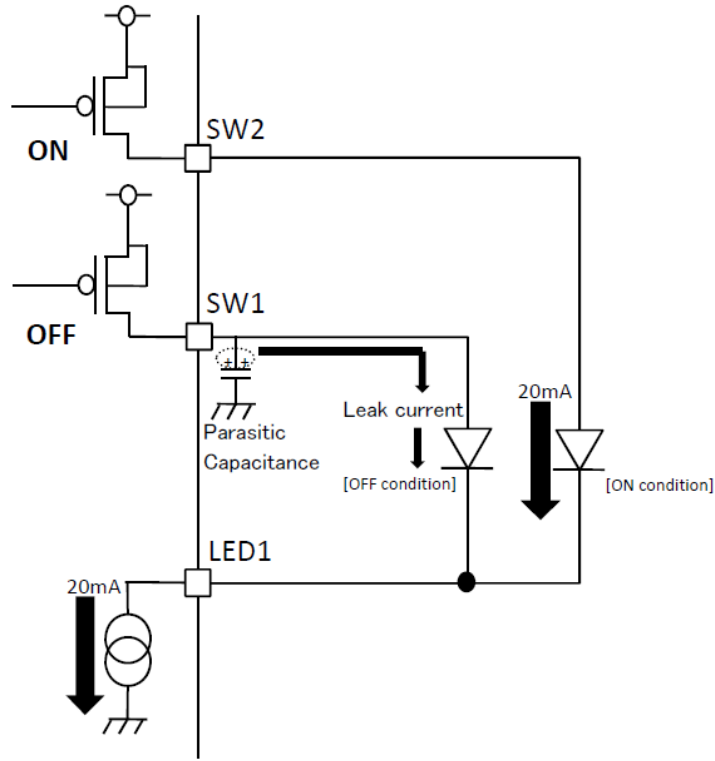
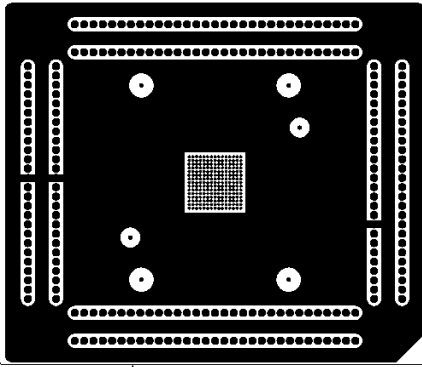
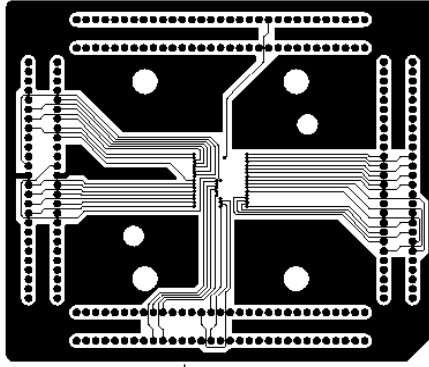

Fig.20 example: A little lighting LED
 Matrix: SW1-LED1=0mA, SW2-LED1=20mA

●PCB pattern of the Power dissipation measuring board



1st layer(component)



2nd layer

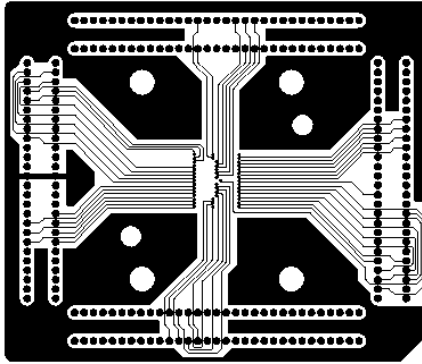

3rd layer

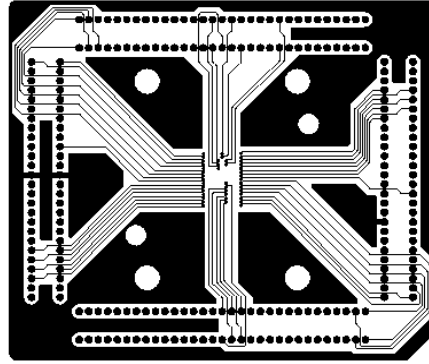

4th layer

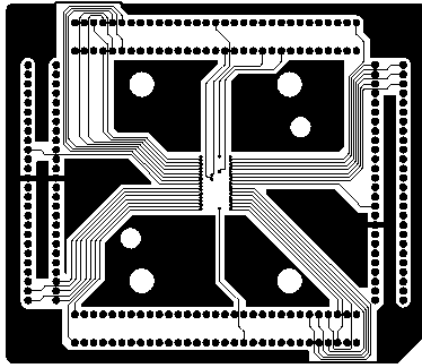

5th layer

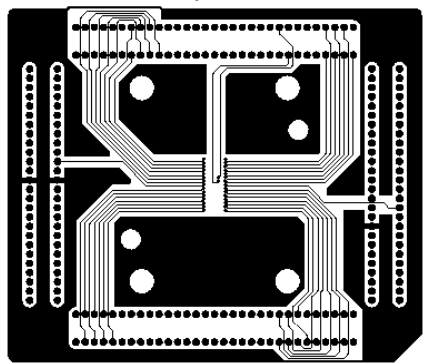

6th layer

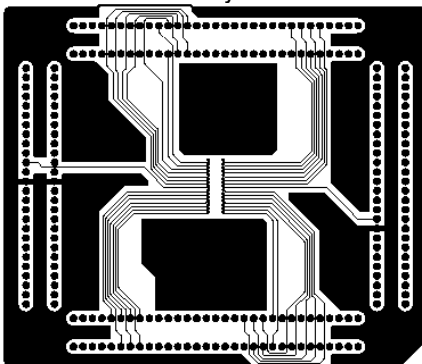

7th layer

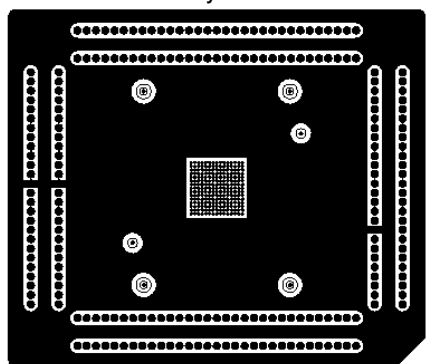

8th layer(solder)

●Notes for use

- (1) Absolute Maximum Ratings
An excess in the absolute maximum ratings, such as supply voltage, temperature range of operating conditions, etc., can break down devices, thus making impossible to identify breaking mode such as a short circuit or an open circuit. If any special mode exceeding the absolute maximum ratings is assumed, consideration should be given to take physical safety measures including the use of fuses, etc.
- (2) Power supply and ground line
Design PCB pattern to provide low impedance for the wiring between the power supply and the ground lines. Pay attention to the interference by common impedance of layout pattern when there are plural power supplies and ground lines. Especially, when there are ground pattern for small signal and ground pattern for large current included the external circuits, please separate each ground pattern. Furthermore, for all power supply pins to ICs, mount a capacitor between the power supply and the ground pin. At the same time, in order to use a capacitor, thoroughly check to be sure the characteristics of the capacitor to be used present no problem including the occurrence of capacity dropout at a low temperature, thus determining the constant.
- (3) Ground voltage
Make setting of the potential of the ground pin so that it will be maintained at the minimum in any operating state. Furthermore, check to be sure no pins are at a potential lower than the ground voltage including an actual electric transient.
- (4) Short circuit between pins and erroneous mounting
In order to mount ICs on a set PCB, pay thorough attention to the direction and offset of the ICs. Erroneous mounting can break down the ICs. Furthermore, if a short circuit occurs due to foreign matters entering between pins or between the pin and the power supply or the ground pin, the ICs can break down.
- (5) Operation in strong electromagnetic field
Be noted that using ICs in the strong electromagnetic field can malfunction them.
- (6) Input pins
In terms of the construction of IC, parasitic elements are inevitably formed in relation to potential. The operation of the parasitic element can cause interference with circuit operation, thus resulting in a malfunction and then breakdown of the input pin. Therefore, pay thorough attention not to handle the input pins, such as to apply to the input pins a voltage lower than the ground respectively, so that any parasitic element will operate. Furthermore, do not apply a voltage to the input pins when no power supply voltage is applied to the IC. In addition, even if the power supply voltage is applied, apply to the input pins a voltage lower than the power supply voltage or within the guaranteed value of electrical characteristics.
- (7) External capacitor
In order to use a ceramic capacitor as the external capacitor, determine the constant with consideration given to a degradation in the nominal capacitance due to DC bias and changes in the capacitance due to temperature, etc.
- (8) Thermal shutdown circuit (TSD)
This LSI builds in a thermal shutdown (TSD) circuit. When junction temperatures become detection temperature or higher, the thermal shutdown circuit operates and turns a switch OFF. The thermal shutdown circuit, which is aimed at isolating the LSI from thermal runaway as much as possible, is not aimed at the protection or guarantee of the LSI. Therefore, do not continuously use the LSI with this circuit operating or use the LSI assuming its operation.
- (9) Thermal design
Perform thermal design in which there are adequate margins by taking into account the permissible dissipation (Pd) in actual states of use.
- (10) About the pin for the test, the un-use pin
Prevent a problem from being in the pin for the test and the un-use pin under the state of actual use. Please refer to a function manual and an application notebook. And, as for the pin that doesn't specially have an explanation, ask our company person in charge.
- (11) About the rush current
For ICs with more than one power supply, it is possible that rush current may flow instantaneously due to the internal powering sequence and delays. Therefore, give special consideration to power coupling capacitance, power wiring, width of ground wiring, and routing of wiring.
- (12) About the function description or application note or more.
The function description and the application notebook are the design materials to design a set. So, the contents of the materials aren't always guaranteed. Please design application by having fully examination and evaluation include the external elements.
- (13) SW1-7 don't have short protection.
When need protection, please use fuse element.

●Ordering part number

B	D
---	---

Part No.

2	6	5	0	3
---	---	---	---	---

Part No.

G	U	L
---	---	---

Package
GUL : VCSP50L3

-

E	2
---	---

Packaging and forming specification
E2: Embossed tape and reel

Notice

Precaution on using ROHM Products

- Our Products are designed and manufactured for application in ordinary electronic equipments (such as AV equipment, OA equipment, telecommunication equipment, home electronic appliances, amusement equipment, etc.). If you intend to use our Products in devices requiring extremely high reliability (such as medical equipment ^(Note 1), transport equipment, traffic equipment, aircraft/spacecraft, nuclear power controllers, fuel controllers, car equipment including car accessories, safety devices, etc.) and whose malfunction or failure may cause loss of human life, bodily injury or serious damage to property ("Specific Applications"), please consult with the ROHM sales representative in advance. Unless otherwise agreed in writing by ROHM in advance, ROHM shall not be in any way responsible or liable for any damages, expenses or losses incurred by you or third parties arising from the use of any ROHM's Products for Specific Applications.

(Note1) Medical Equipment Classification of the Specific Applications

JAPAN	USA	EU	CHINA
CLASS III	CLASS III	CLASS II b	CLASS III
CLASS IV		CLASS III	

- ROHM designs and manufactures its Products subject to strict quality control system. However, semiconductor products can fail or malfunction at a certain rate. Please be sure to implement, at your own responsibilities, adequate safety measures including but not limited to fail-safe design against the physical injury, damage to any property, which a failure or malfunction of our Products may cause. The following are examples of safety measures:
 - Installation of protection circuits or other protective devices to improve system safety
 - Installation of redundant circuits to reduce the impact of single or multiple circuit failure
- Our Products are designed and manufactured for use under standard conditions and not under any special or extraordinary environments or conditions, as exemplified below. Accordingly, ROHM shall not be in any way responsible or liable for any damages, expenses or losses arising from the use of any ROHM's Products under any special or extraordinary environments or conditions. If you intend to use our Products under any special or extraordinary environments or conditions (as exemplified below), your independent verification and confirmation of product performance, reliability, etc. prior to use, must be necessary:
 - Use of our Products in any types of liquid, including water, oils, chemicals, and organic solvents
 - Use of our Products outdoors or in places where the Products are exposed to direct sunlight or dust
 - Use of our Products in places where the Products are exposed to sea wind or corrosive gases, including Cl₂, H₂S, NH₃, SO₂, and NO₂
 - Use of our Products in places where the Products are exposed to static electricity or electromagnetic waves
 - Use of our Products in proximity to heat-producing components, plastic cords, or other flammable items
 - Sealing or coating our Products with resin or other coating materials
 - Use of our Products without cleaning residue of flux (even if you use no-clean type fluxes, cleaning residue of flux is recommended); or Washing our Products by using water or water-soluble cleaning agents for cleaning residue after soldering
 - Use of the Products in places subject to dew condensation
- The Products are not subject to radiation-proof design.
- Please verify and confirm characteristics of the final or mounted products in using the Products.
- In particular, if a transient load (a large amount of load applied in a short period of time, such as pulse. is applied, confirmation of performance characteristics after on-board mounting is strongly recommended. Avoid applying power exceeding normal rated power; exceeding the power rating under steady-state loading condition may negatively affect product performance and reliability.
- De-rate Power Dissipation (Pd) depending on Ambient temperature (Ta). When used in sealed area, confirm the actual ambient temperature.
- Confirm that operation temperature is within the specified range described in the product specification.
- ROHM shall not be in any way responsible or liable for failure induced under deviant condition from what is defined in this document.

Precaution for Mounting / Circuit board design

- When a highly active halogenous (chlorine, bromine, etc.) flux is used, the residue of flux may negatively affect product performance and reliability.
- In principle, the reflow soldering method must be used; if flow soldering method is preferred, please consult with the ROHM representative in advance.

For details, please refer to ROHM Mounting specification

Precautions Regarding Application Examples and External Circuits

1. If change is made to the constant of an external circuit, please allow a sufficient margin considering variations of the characteristics of the Products and external components, including transient characteristics, as well as static characteristics.
2. You agree that application notes, reference designs, and associated data and information contained in this document are presented only as guidance for Products use. Therefore, in case you use such information, you are solely responsible for it and you must exercise your own independent verification and judgment in the use of such information contained in this document. ROHM shall not be in any way responsible or liable for any damages, expenses or losses incurred by you or third parties arising from the use of such information.

Precaution for Electrostatic

This Product is electrostatic sensitive product, which may be damaged due to electrostatic discharge. Please take proper caution in your manufacturing process and storage so that voltage exceeding the Products maximum rating will not be applied to Products. Please take special care under dry condition (e.g. Grounding of human body / equipment / solder iron, isolation from charged objects, setting of Ionizer, friction prevention and temperature / humidity control).

Precaution for Storage / Transportation

1. Product performance and soldered connections may deteriorate if the Products are stored in the places where:
 - [a] the Products are exposed to sea winds or corrosive gases, including Cl₂, H₂S, NH₃, SO₂, and NO₂
 - [b] the temperature or humidity exceeds those recommended by ROHM
 - [c] the Products are exposed to direct sunshine or condensation
 - [d] the Products are exposed to high Electrostatic
2. Even under ROHM recommended storage condition, solderability of products out of recommended storage time period may be degraded. It is strongly recommended to confirm solderability before using Products of which storage time is exceeding the recommended storage time period.
3. Store / transport cartons in the correct direction, which is indicated on a carton with a symbol. Otherwise bent leads may occur due to excessive stress applied when dropping of a carton.
4. Use Products within the specified time after opening a humidity barrier bag. Baking is required before using Products of which storage time is exceeding the recommended storage time period.

Precaution for Product Label

QR code printed on ROHM Products label is for ROHM's internal use only.

Precaution for Disposition

When disposing Products please dispose them properly using an authorized industry waste company.

Precaution for Foreign Exchange and Foreign Trade act

Since our Products might fall under controlled goods prescribed by the applicable foreign exchange and foreign trade act, please consult with ROHM representative in case of export.

Precaution Regarding Intellectual Property Rights

1. All information and data including but not limited to application example contained in this document is for reference only. ROHM does not warrant that foregoing information or data will not infringe any intellectual property rights or any other rights of any third party regarding such information or data. ROHM shall not be in any way responsible or liable for infringement of any intellectual property rights or other damages arising from use of such information or data.:
2. No license, expressly or implied, is granted hereby under any intellectual property rights or other rights of ROHM or any third parties with respect to the information contained in this document.

Other Precaution

1. This document may not be reprinted or reproduced, in whole or in part, without prior written consent of ROHM.
2. The Products may not be disassembled, converted, modified, reproduced or otherwise changed without prior written consent of ROHM.
3. In no event shall you use in any way whatsoever the Products and the related technical information contained in the Products or this document for any military purposes, including but not limited to, the development of mass-destruction weapons.
4. The proper names of companies or products described in this document are trademarks or registered trademarks of ROHM, its affiliated companies or third parties.

General Precaution

1. Before you use our Products, you are requested to carefully read this document and fully understand its contents. ROHM shall not be in any way responsible or liable for failure, malfunction or accident arising from the use of any ROHM's Products against warning, caution or note contained in this document.
2. All information contained in this document is current as of the issuing date and subject to change without any prior notice. Before purchasing or using ROHM's Products, please confirm the latest information with a ROHM sales representative.
3. The information contained in this document is provided on an "as is" basis and ROHM does not warrant that all information contained in this document is accurate and/or error-free. ROHM shall not be in any way responsible or liable for any damages, expenses or losses incurred by you or third parties resulting from inaccuracy or errors of or concerning such information.