

PRODUCT NUMBER  
SEE TABLE

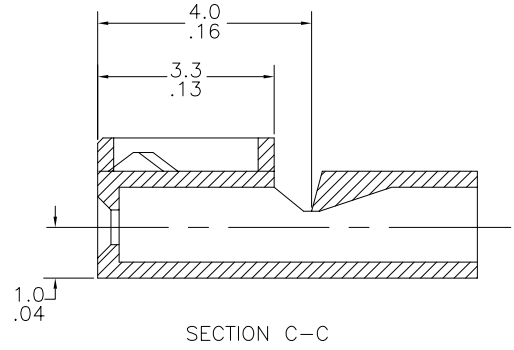

mat'l. code SEE NOTE 1				surface	tolerance	projection	product family
SEE NOTE 1							MINITEK HOUSINGS
ltr	ecr no	dr	date	tolerances unless otherwise specified		MM/INCH	title
A	v08-0103	HTB	2008-02-29	angles	.X+3/XX+01		MINITEK C.T.W. HOUSING SINGLE ROW
B	v08-0393	HTB	2008-09-12	linear	XX+13/XXX+005	scale 8:1	POLARIZED WITH LATCH, HIGH-TEMP
				0°±2°	XXX+051/XXXX+0020		dwg no
				dr	T. BREWBAKER 2008-02-29		sheet 1 of 2
				engr	T. BREWBAKER 2008-02-29		10087009
				chr	T. BREWBAKER 2008-02-29		A3
				appd	T. BREWBAKER 2008-02-29		type
sheet	revision	B	B				Product Customer Drawing
index	sheet	1	2				

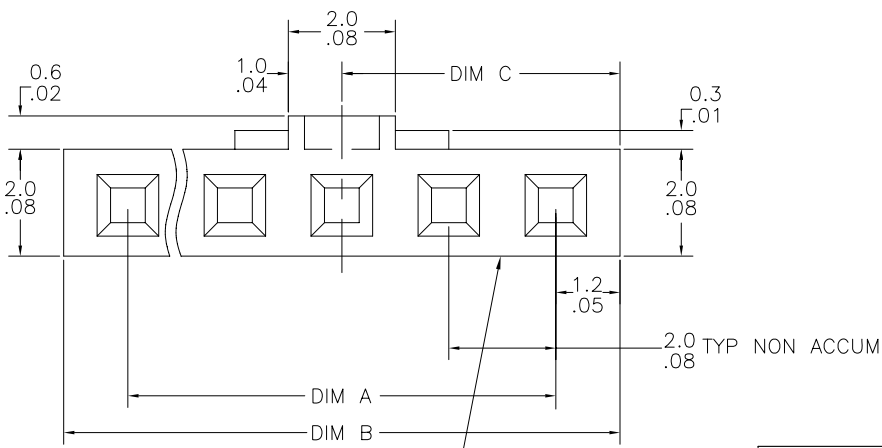
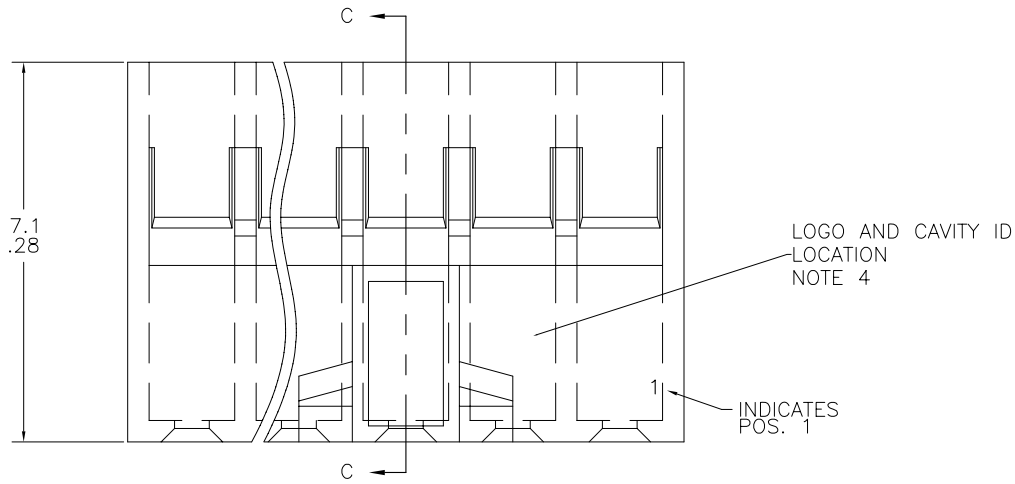

Copyright FCJ

PRODUCT NUMBER	POSITIONS	DIM A	DIM B	DIM C	LATCHING FEATURES	EQUIVALENT STANDARD P/N
10087009-003LF	1 X 3	4.0/.16	6.4/.25	3.2/.13	2	90312-003LF
10087009-004LF	1 X 4	6.0/.24	8.4/.33	4.2/.17	2	90312-004LF
10087009-005LF	1 X 5	8.0/.32	10.4/.41	5.2/.21	2	90312-005LF
10087009-006LF	1 X 6	10.0/.39	12.4/.49	6.2/.24	2	90312-006LF
10087009-007LF	1 X 7	12.0/.47	14.4/.57	7.2/.28	2	90312-007LF
10087009-008LF	1 X 8	14.0/.55	16.4/.65	8.2/.32	2	90312-008LF
10087009-009LF	1 X 9	16.0/.63	18.4/.72	9.2/.36	2	90312-009LF
10087009-010LF	1 X 10	18.0/.71	20.4/.80	10.2/.40	2	90312-010LF
10087009-011LF	1 X 11	20.0/.79	22.4/.88	11.2/.44	2	90312-011LF
10087009-012LF	1 X 12	22.0/.87	24.4/.96	12.2/.48	2	90312-012LF
10087009-013LF	1 X 13	24.0/.95	26.4/1.04	13.2/.52	2	90312-013LF
10087009-014LF	1 X 14	26.0/1.02	28.4/1.12	14.2/.56	2	90312-014LF
10087009-015LF	1 X 15	28.0/1.10	30.4/1.20	15.2/.60	2	90312-015LF
10087009-016LF	1 X 16	30.0/1.18	32.4/1.28	16.2/.64	2	90312-016LF
10087009-017LF	1 X 17	32.0/1.26	34.4/1.35	17.2/.68	2	90312-017LF

NOTES:

- ① MATERIAL: UNFILLED FLAME RETARDANT NYLON, FLAME RETARDANT PER UL94V-0, COLOR: BLACK OPERATING TEMPERATURE: -40°C TO +130°C
2. FOR USE WITH MINITEK LATCHING HEADERS WHEN MATING AND UNMATING THE FORCES WILL BE APPROX 1Kg/2.2LBS GREATER THAN THE FORCES DETAILED IN DPS-12-011, PARAGRAPH 3.5 & 3.4.
3. LOGO ON 1 x 5'S AND LARGER.
- ④ LOGO AND CAVITY ID LOCATION TO BE DETERMINED BY MANUFACTURER.
5. PRODUCT MEETS EUROPEAN UNION DIRECTIVES AND OTHER COUNTRY REGULATIONS AS DESCRIBED IN GS-22-008.
6. THIS PRODUCT IS NOT INTENDED TO BE EXPOSED TO MANUFACTURING SOLDER PROCESSES.



FCIconnect.com

Copyright FCI

mat'l. code SEE NOTE 1				surface <input checked="" type="checkbox"/> tolerance		projection		product family MINITEK HOUSINGS		
ltr	ecn no	dr	date	tolerances unless otherwise specified		MM/INCH		title		
B				angles	linear	.X+3/XX+01		MINITEK C.T.W. HOUSING SINGLE ROW		
				0°±2'		XX+13/XXX+005		POLARIZED WITH LATCH, HIGH-TEMP		
						XXX+051/XXXX+0020		scale 8:1		
				dr	T. BREWBAKER	2008-02-29			dwg no	
				engr	T. BREWBAKER	2008-02-29			sheet 2 of 2	size
				chr	T. BREWBAKER	2008-02-29			10087009	A3
				appd	T. BREWBAKER	2008-02-29			type	Product Customer Drawing
sheet index	revision	sheet								