

4.2 W off-line LED driver with primary side regulation

Data brief

Features

- Input voltage range (V_{IN}): 185 - 265 V_{AC}
- Main frequency (f_L): 50 - 60 Hz
- Maximum (rated) output power: 4.2 W
- Output: $I_{OUT} = 350 \text{ mA} \pm 5\%$
 - Over voltage = 12 V max
 - Current ripple < 10% I_{OUT}
- Minimum switching frequency in normal mode: 70 kHz
- Target average efficiency (from 1 to 3 LEDs) > 70 %
- Maximum input power in no-load < 100 mW



Description

The EVALHVLED805 is a demonstration board equipped with the new HVLED805 PWM current mode LED driver and is designed for European mains. It can control, with very good accuracy, from 1 to 3 LEDs having a nominal current of 350 mA. The HVLED805 has integrated high voltage startup and an 800 V power MOSFET. The high MOSFET's breakdown voltage allows very robust and reliable applications and reduces the size of the snubber and the relative power dissipation. Its accurate primary-current control eliminates the need of the optocoupler which impacts the cost, the compactness and the lifetime of the application while still maintaining a very good LED accuracy (below 5 %). Moreover, this converter, specifically designed for quasi-resonant (QR) flyback converters, enables very low turn-on losses and EMI emissions.

1 Electrical schematic

Figure 1. EVALHVLED805 electrical schematic

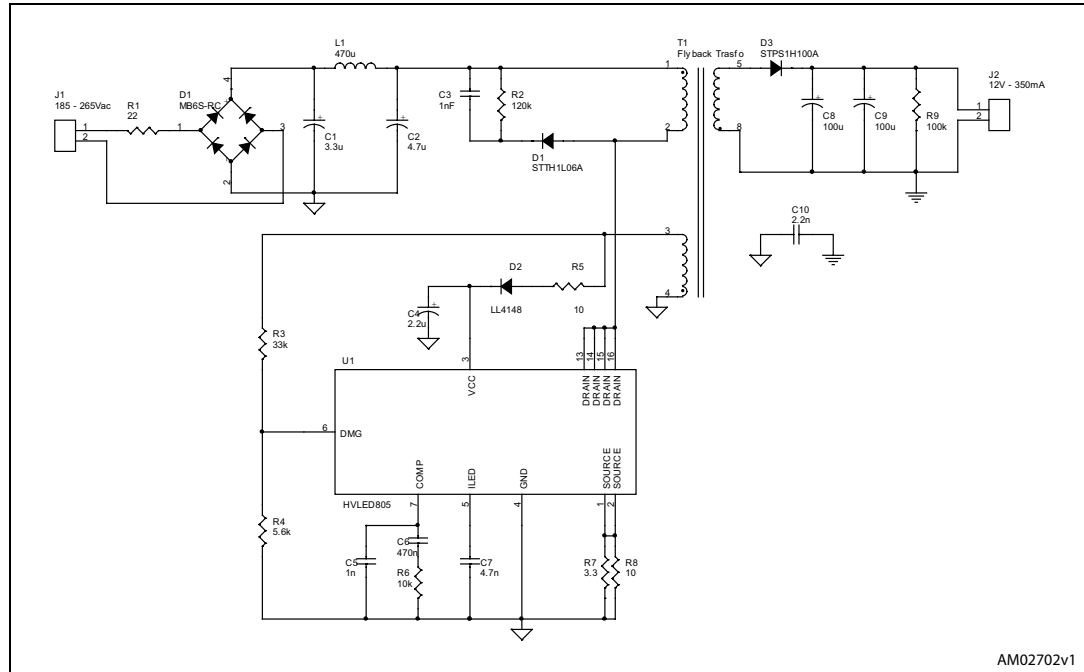

AM02702v1

1.1 Efficiency measurement

Figure 2. Efficiency measurement with one, two or three LEDs

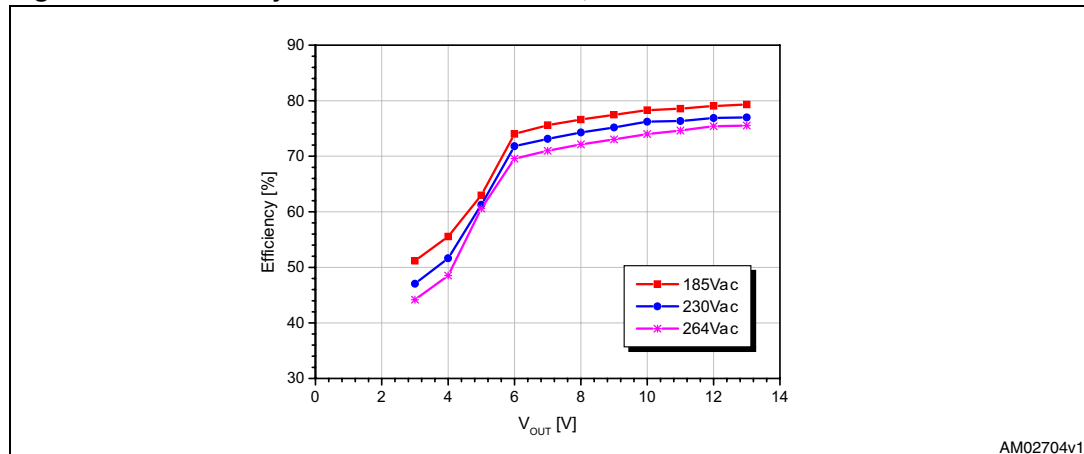

AM02704v1

The efficiency is always higher than 70 % when two or three LEDs are connected, whereas it drops with one LED. The reason is that at low output voltage, the auxiliary voltage is not able to supply the IC and the internal HV current generator self supplies the Vcc pin, thus dissipating a power proportional to VIN.

The output current has been measured with two or three LEDs which obtain an accuracy always below 5 %.

Figure 3. Output current characteristics

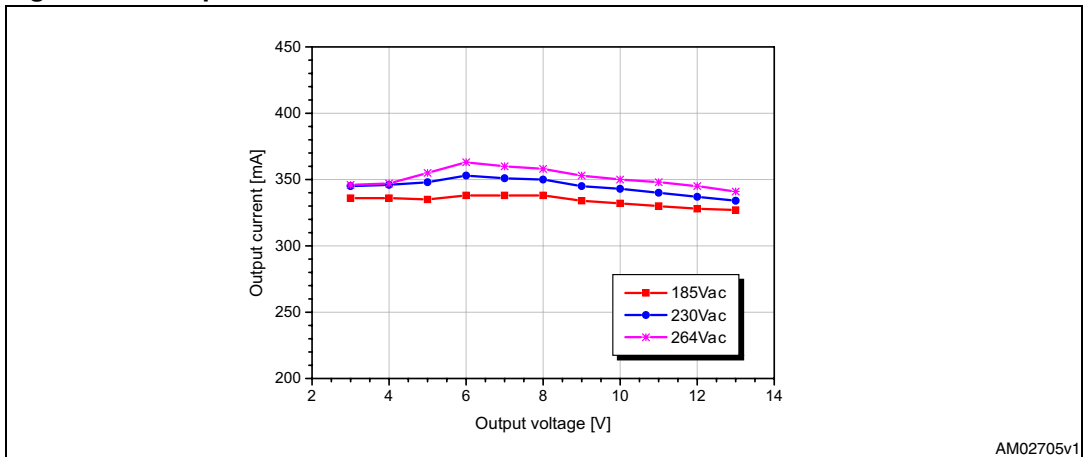

AM02705v1

Figure 4. Start up at 230 VAC, 3 LEDs

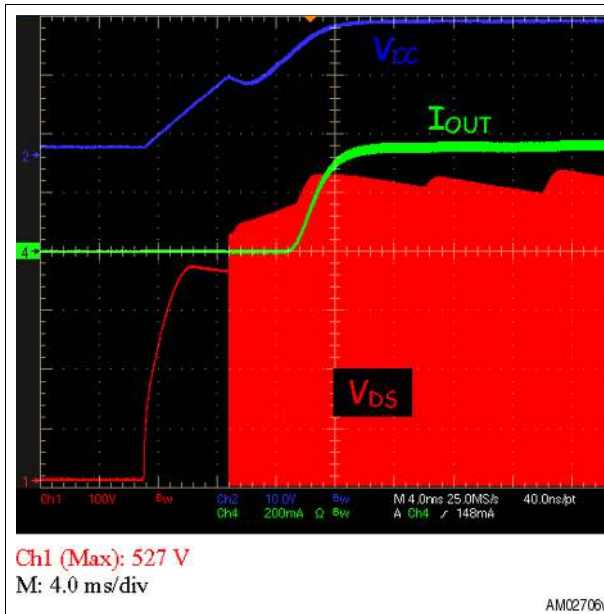

Figure 5. Start up at 230 VAC, 1LEDs

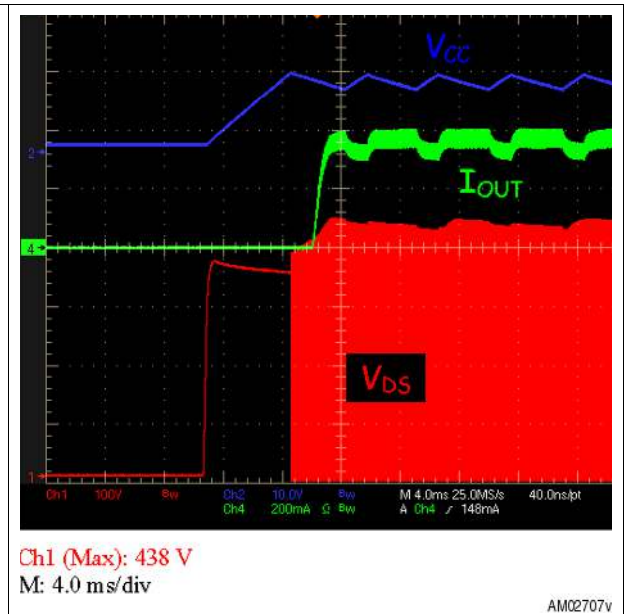

Figure 6. Normal operation at 230 VAC, 3 LEDs

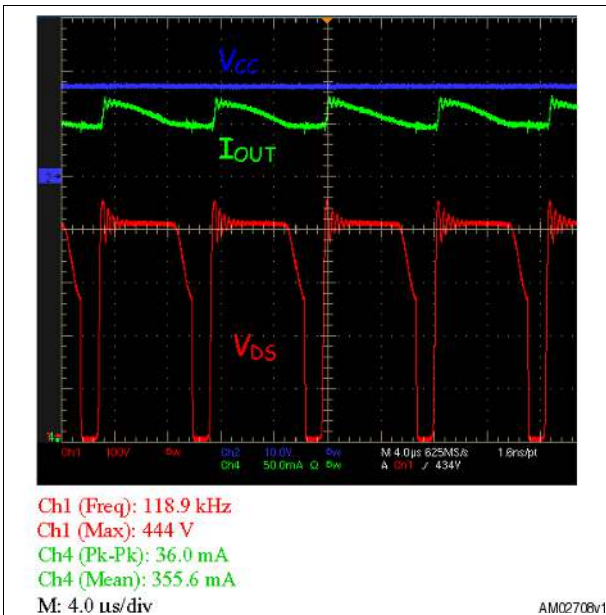

Figure 7. Normal operation at 230 VAC, 2 LEDs

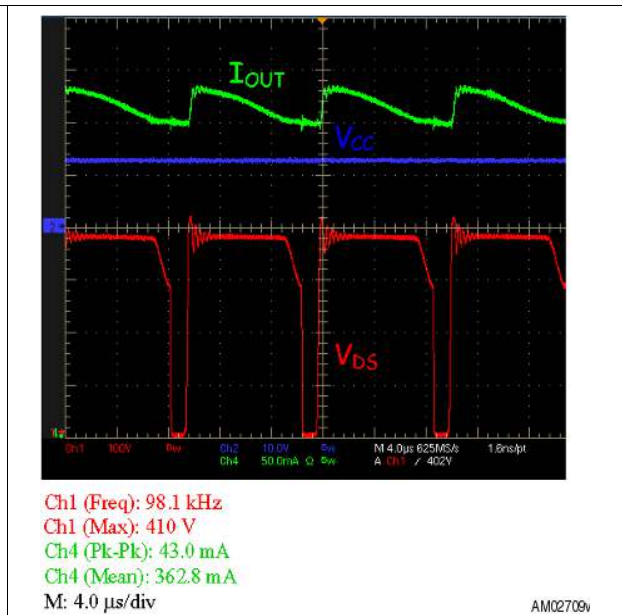

Figure 8. Normal operation at 230 VAC: 1 LEDs

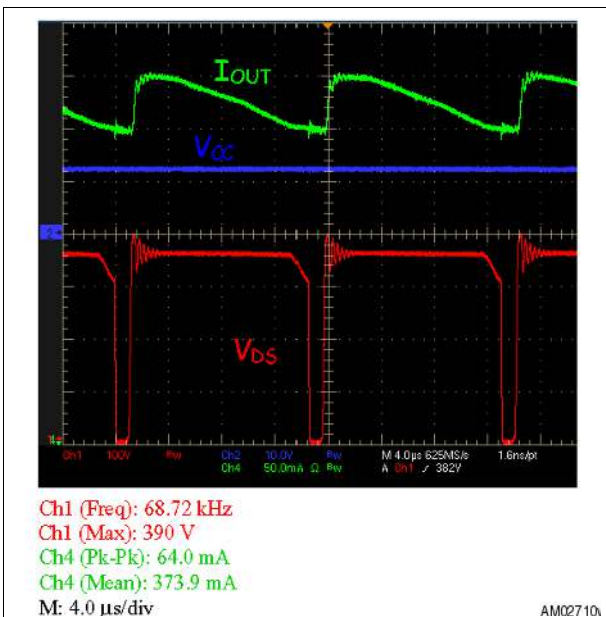
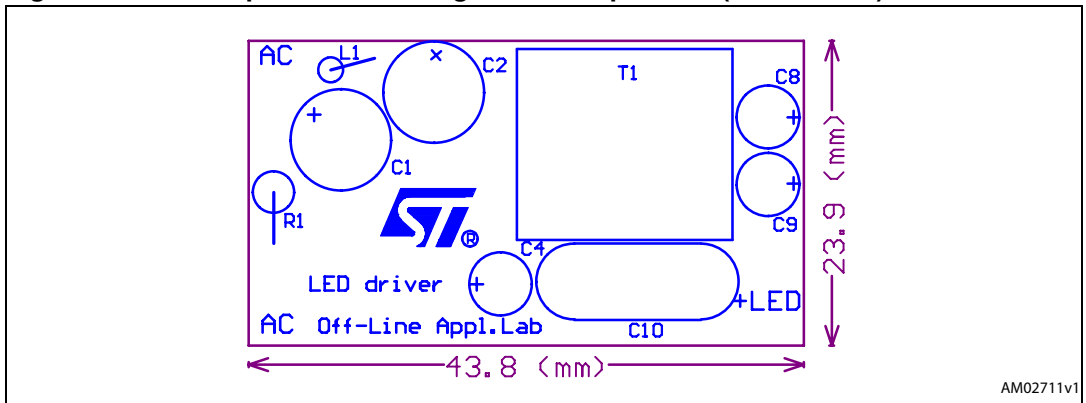
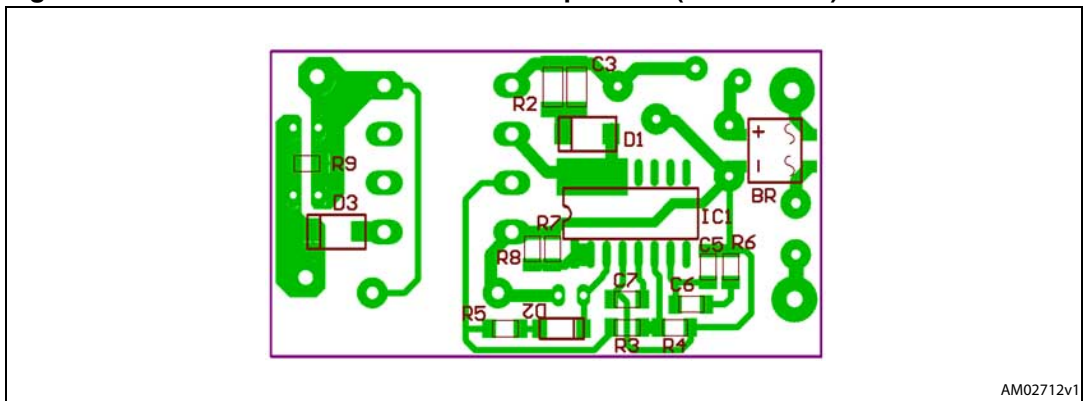

Figure 9. PCB top side and through hole components (not in scale)



AM02711v1

Figure 10. PCB: bottom side and SMD components (not in scale)



AM02712v1

Table 1. Bill of material

Reference	Part	Description	Note
R1		22 Ω	1 W - Axial flame proof
R2		120 k Ω	
R3		33 k Ω	
R4		5.6 k Ω	
R5		10 Ω	
R6		10 k Ω	
R7		3.3 k Ω	1% tolerance
R8		10 Ω	1% tolerance
R9		100 k Ω	
C1, C2		2.2 μ F	400 V electrolytic
C3		1 nF	500 V - XR7
C4		2.2 μ F	35 V electrolytic
C5		1 nF	25 V
C6		470 nF	25 V
C7		4.7 nF	25 V
C8, C9	B41889A3108M	100 μ F	16V electrolytic Rubycon ZLH
C10	Y1- Capacitor	2.2 nF	230V
D1	STTH1L06A	Ultra-fast high voltage diode	STMicroelectronics
D2	LL4148	Small signal diode	
D3	STPS1H100A	Power schottky diode	STMicroelectronics
L1	B78108S1474J	470 μ H	axial inductor Epcos
BR	MB6S RC	Input bridge rectifier	
TF	1921.0013 Rev04	Flyback transformer	Magnetics
IC	HVLED805	Primary switching regulator	STMicroelectronics

Note: If not otherwise specified, all resistors are 5%, 1/4 W

Table 2. Transformer characteristics

Manufacturer	Magnetica
Part number	1921.0013 Rev. 04
Core	E13 – N87 (or equivalent)
Primary inductance	2.6mH ± 15%
Air gap	~ 70 µm
Leakage inductance	1.42% nom
Primary to secondary turn ratio	7.68 ± 5% 123:16
Primary to auxiliary turn ratio	5.59 ± 5% 123:22
Primary saturation current	0.21A _P max (B _{SAT} =0.35 T)
Insulation primary-secondary	4 kV

Figure 11. Transformer electrical scheme and dimensions

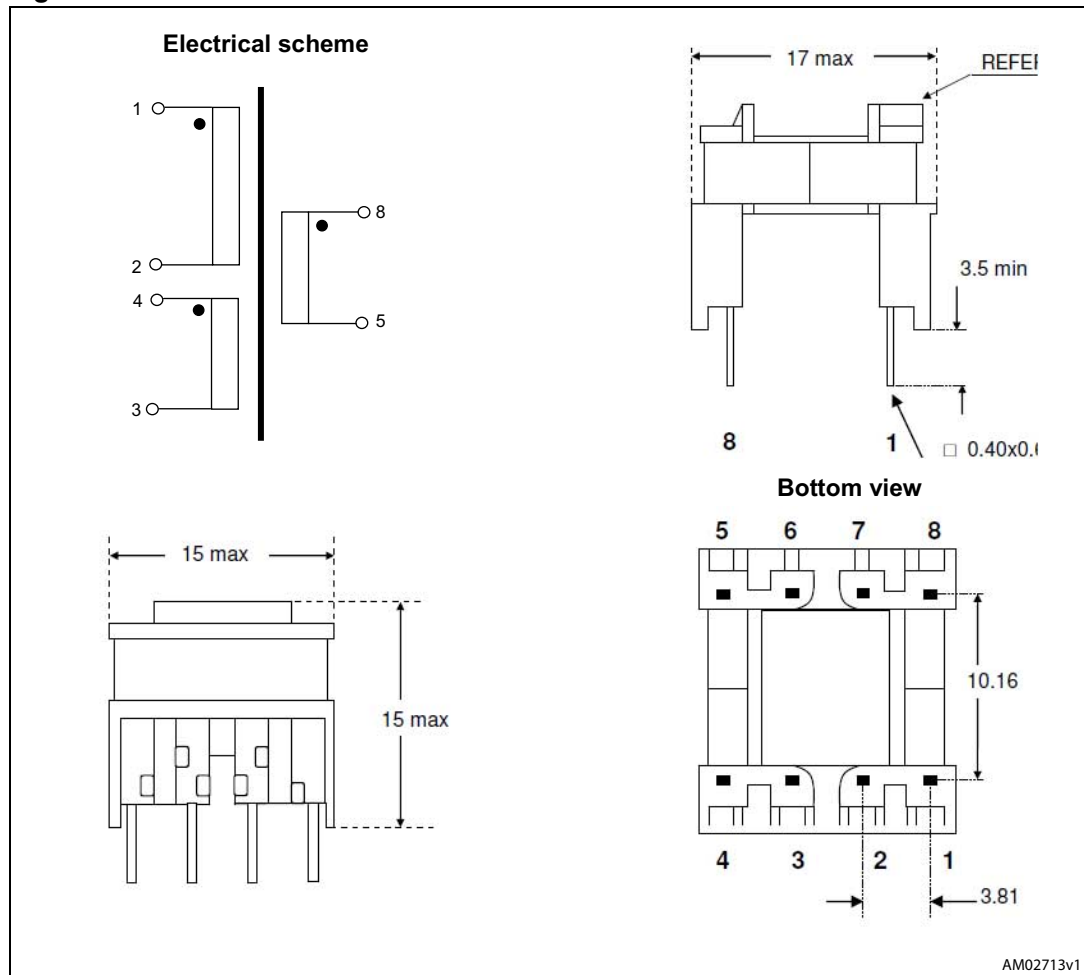

2 Revision history

Table 3. Document revision history

Date	Revision	Changes
09-Feb-2011	1	First release
16-Nov-2011	2	Updated <i>Figure 1, Table 1, Table 2, Figure 9, Figure 11</i>

Please Read Carefully:

Information in this document is provided solely in connection with ST products. STMicroelectronics NV and its subsidiaries ("ST") reserve the right to make changes, corrections, modifications or improvements, to this document, and the products and services described herein at any time, without notice.

All ST products are sold pursuant to ST's terms and conditions of sale.

Purchasers are solely responsible for the choice, selection and use of the ST products and services described herein, and ST assumes no liability whatsoever relating to the choice, selection or use of the ST products and services described herein.

No license, express or implied, by estoppel or otherwise, to any intellectual property rights is granted under this document. If any part of this document refers to any third party products or services it shall not be deemed a license grant by ST for the use of such third party products or services, or any intellectual property contained therein or considered as a warranty covering the use in any manner whatsoever of such third party products or services or any intellectual property contained therein.

UNLESS OTHERWISE SET FORTH IN ST'S TERMS AND CONDITIONS OF SALE ST DISCLAIMS ANY EXPRESS OR IMPLIED WARRANTY WITH RESPECT TO THE USE AND/OR SALE OF ST PRODUCTS INCLUDING WITHOUT LIMITATION IMPLIED WARRANTIES OF MERCHANTABILITY, FITNESS FOR A PARTICULAR PURPOSE (AND THEIR EQUIVALENTS UNDER THE LAWS OF ANY JURISDICTION), OR INFRINGEMENT OF ANY PATENT, COPYRIGHT OR OTHER INTELLECTUAL PROPERTY RIGHT.

UNLESS EXPRESSLY APPROVED IN WRITING BY TWO AUTHORIZED ST REPRESENTATIVES, ST PRODUCTS ARE NOT RECOMMENDED, AUTHORIZED OR WARRANTED FOR USE IN MILITARY, AIR CRAFT, SPACE, LIFE SAVING, OR LIFE SUSTAINING APPLICATIONS, NOR IN PRODUCTS OR SYSTEMS WHERE FAILURE OR MALFUNCTION MAY RESULT IN PERSONAL INJURY, DEATH, OR SEVERE PROPERTY OR ENVIRONMENTAL DAMAGE. ST PRODUCTS WHICH ARE NOT SPECIFIED AS "AUTOMOTIVE GRADE" MAY ONLY BE USED IN AUTOMOTIVE APPLICATIONS AT USER'S OWN RISK.

Resale of ST products with provisions different from the statements and/or technical features set forth in this document shall immediately void any warranty granted by ST for the ST product or service described herein and shall not create or extend in any manner whatsoever, any liability of ST.

ST and the ST logo are trademarks or registered trademarks of ST in various countries.

Information in this document supersedes and replaces all information previously supplied.

The ST logo is a registered trademark of STMicroelectronics. All other names are the property of their respective owners.

© 2011 STMicroelectronics - All rights reserved

STMicroelectronics group of companies

Australia - Belgium - Brazil - Canada - China - Czech Republic - Finland - France - Germany - Hong Kong - India - Israel - Italy - Japan - Malaysia - Malta - Morocco - Philippines - Singapore - Spain - Sweden - Switzerland - United Kingdom - United States of America

www.st.com