

EMD-FL-RP-480

Electronic monitoring relay for active-power monitoring in 1 and 3-phase networks with integrated motor coil temperature monitoring

INTERFACE

Data sheet
104136_en_00

© PHOENIX CONTACT 2010-01-22



1 Description

Requirements pertaining to safety and system availability increase constantly – regardless of the industry. Processes are becoming more and more complex, not only in the mechanical engineering and chemical industry but also in system and automation technology. Demands on power engineering are also constantly on the rise.

Error-free and therefore cost-effective operation can only be achieved through continuous monitoring of important network and system parameters. The electronic monitoring relays of the EMD series are available for various monitoring tasks.

The operating states are indicated using colored LEDs, errors that may occur can be sent to a controller via a floating contact or can shut down a part of the system. Some device versions are equipped with startup and response delays in order to briefly tolerate measured values outside the set monitoring range.

Features

- Active power detection in 1 and 3-phase networks
- 2 threshold values, can be set separately
- Adjustable starting override
- Adjustable response delay
- Error memory (optional)
- Temperature monitoring of the motor winding
- Power supply can be selected with power module
- Detecting switched off loads
- Suitable for frequency inverters (10 to 100 Hz)
- Two output relays with one PDT contact each



WARNING: Risk of electric shock

Never carry out work when voltage is present.



Make sure you always use the latest documentation.
It can be downloaded at www.phoenixcontact.net/catalog.

2 Ordering data

Description	Type	Order No.	Pcs. / Pkt.
Electronic monitoring relay for active-power monitoring in 1 and 3-phase networks with integrated motor coil temperature monitoring	EMD-FL-RP-480	2900177	1
Accessories	Type	Order No.	Pcs. / Pkt.
Power modules, pluggable, for EMD-FL-..., supply voltage: 88 V AC ... 121 V AC	EMD-SL-PS45-110AC	2885281	1
Power modules, pluggable, for EMD-FL-..., supply voltage: 108 V AC ... 132 V AC	EMD-SL-PS45-120AC	2885744	1
Power modules, pluggable, for EMD-FL-..., supply voltage: 195 V AC ... 264 V AC	EMD-SL-PS45-230AC	2885294	1
Power modules, pluggable, for EMD-FL-..., supply voltage: 323...456 V AC	EMD-SL-PS45-400AC	2885304	1
Power modules, pluggable, for EMD-FL-..., supply voltage: 425...550 V AC	EMD-SL-PS45-500AC	2885317	1

3 Technical data

Input data	
Input name	Measuring input
Description of the input	Voltage input
Measured value	AC sine (10 Hz ... 400 Hz)
Measuring ranges P_N	Can be switched between 0.75 kW, 1.5 kW, 3 kW and 6 kW
Nominal input voltage U_N	480 V (3 N ~ 480/277 V)
Input voltage range	1(N) ~ 0 V AC ... 480 V AC (1-phase load) 3(N) ~ 0 V AC ... 480 V AC (3-phase load)
Maximum input voltage	max. 550 V AC (/3~550/318)
Input current range	0.15 A ... 6 A (Range: 0.75 kW and 1.5 kW) 0.3 A ... 12 A (Range: 3 kW and 6 kW)
Overload capacity	12 A permanent
Input resistance of voltage input	1.25 M Ω
Input resistance current input	< 10 m Ω
Min. setting range	5 % ... 110 % (of P_N)
Max. setting range	10 % ... 120 % (of P_N)
Maximum temperature coefficient	≤ 0.02 %/K
Setting range for response delay	0.1 s ... 50 s
Setting range for starting delay	1 s ... 100 s
Function	Underload, overload, Window winding temperature monitoring
Basic accuracy	± 2 % (of scale end value)
Setting accuracy	≤ 5 % (of scale end value)
Repeat accuracy	± 2 %
Total cold resistance	< 1.5 k Ω
Response value	≥ 3.6 k Ω (Relay drops out)
Release value	≤ 1.8 k Ω (Relay picks up)
Recovery time	500 ms

Output data

Contact type	2 floating PDT contacts
Nominal insulation voltage	250 V AC (in acc. with IEC 60664-1)
Interrupting rating (ohmic load) max.	750 VA (3 A/250 V AC, module aligned, ≤ 5 mm spacing) 1250 VA (5 A/250 V AC, module not aligned, ≥ 5 mm spacing)
Output fuse	5 A (fast-blow)

Supply

Range of supply voltages	110 V AC ... 500 V AC (see Power modules)
Frequency range	48 Hz ... 63 Hz (See power modules)
Nominal power consumption	3.5 VA (3 W)

General data

Mains type	1 and 3-phase
Service life mechanical	Approx. 2×10^7 cycles
Service life, electrical	2×10^5 cycles at ohmic load, 1000 VA
Switching frequency	max. 60 (per minute at 100 VA ohmic load) max. 6 (per minute at 1000 VA ohmic load)
Operating mode	100% operating factor
Degree of protection	IP40 (housing) / IP20 (connection terminal blocks)
Pollution degree	2 (according to EN 50178)
Surge voltage category	III, basic insulation (as per EN 50178)
Rated insulation voltage	300 V (According to EN 50178)
Assembly	on TS 35 profile rail acc. to EN 60715
Mounting position	Any
Width	45 mm
Height	113 mm
Length	90 mm
Type of housing	Polyamide PA, self-extinguishing
Color	green

Connection data

Conductor cross section, solid	0.5 mm ² ... 2.5 mm ²
Conductor cross section, stranded	0.25 mm ² ... 2.5 mm ²
Stripping length	8 mm
Type of connection	Screw connection
Tightening torque	1 Nm

Ambient conditions

Ambient temperature (operation)	-25 °C ... 55 °C -25 °C ... 40 °C (corresponds to UL 508)
Ambient temperature (storage/transport)	-25 °C ... 70 °C
Permissible humidity (operation)	15 % ... 85 %
Climatic class	3K3 (in acc. with EN 60721)

Conformance / approvals

Conformity	CE compliant
UL, USA / Canada	UL applied for

4 Block diagram

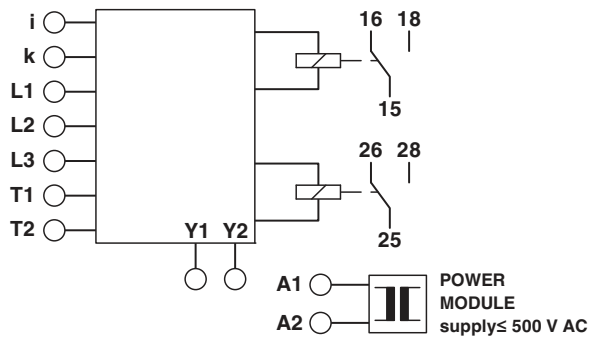

5 Safety notes



WARNING: Risk of electric shock

Never carry out work when voltage is present.

6 Structure

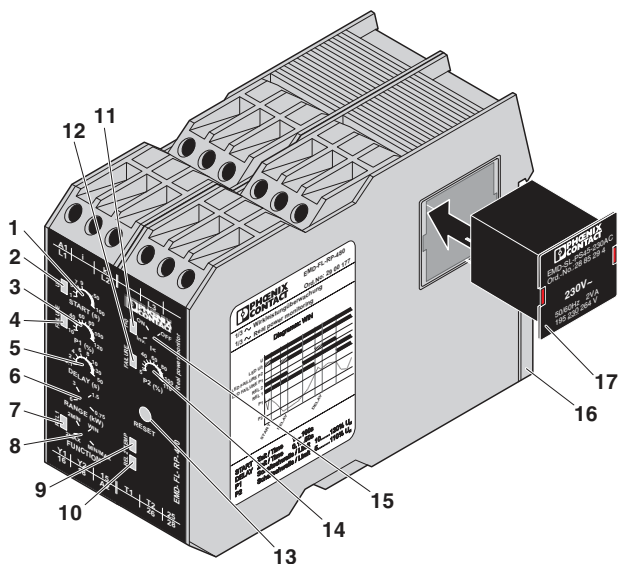

- 1 "START" potentiometer: Starting override
- 2 "U/t" LED: Supply voltage and starting override
- 3 "P1" potentiometer: P1 switching threshold
- 4 "Failure" LED: Error P1 threshold
- 5 "DELAY" potentiometer: Response delay
- 6 "RANGE" rotary switch: Measuring range P_N
- 7 "REL 1" LED: Output relay 1
- 8 "FUNCTION" rotary switch: Function selection
- 9 "TEMP" LED: Overtemperature
- 10 "REL 2" LED: Output relay 2
- 11 "I=0" LED: Load switched off
- 12 "Failure" LED: Error P2 threshold
- 13 RESET button
- 14 "P2" potentiometer: Switching threshold P2
- 15 "<" rotary switch: Detecting switched off loads
- 16 Universal snap-on foot for EN DIN rails
- 17 Power module

7 Power supply

The power module for power supply is supplied in a transport casing to prevent the connection legs from being bent. To install the power module in the relay housing, remove the transport casing and position the power module in the recess in the side of the housing (ensure that it is the right way round). The red locking latches snap in with an audible click when the power module is securely positioned.

To remove the power module, press the two red locking latches together and pull out the power module.



The power module is not supplied as standard.

8 Installation



WARNING: Risk of electric shock

Never carry out work when voltage is present.

The module can be snapped onto all 35 mm DIN rails according to EN 60715.

9 Diagnostics

The LEDs indicate the following error states:

"U/t" LED (Green)

- LED ON: Supply voltage present
- LED flashes: Starting override indication

"I=0" LED (Yellow)

- LED ON: Load switched on

"Failure" LED (red):

- LED ON: Error indication for corresponding threshold P1 or P2
- LED flashes: Response delay indication for corresponding threshold P1 or P2

"Temp" LED (red)

- LED ON: Overtemperature indication

"Rel 1"/"Rel 2" LED (yellow)

- LED ON: Output relay has picked up

10 Connection examples

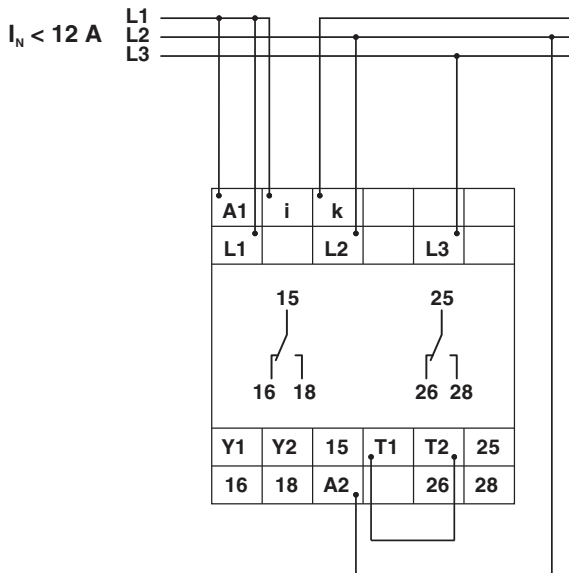

3~ 400 V connection with power module 400 V AC without error memory

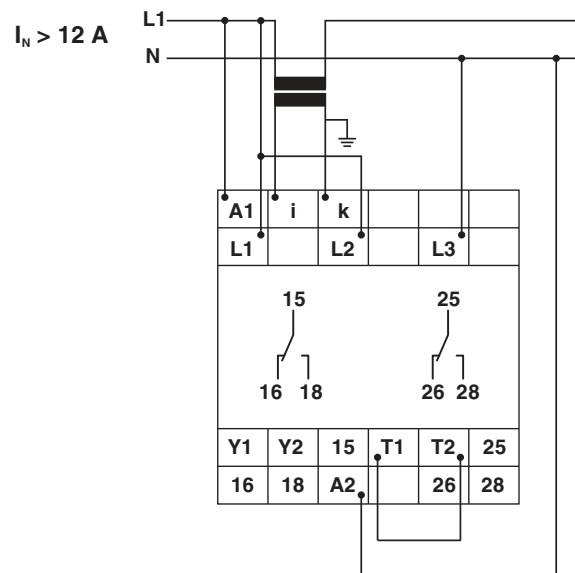

1~ 230 V connection with power module 230 V AC without error memory with current transformer



Terminals **Y1** and **Y2** must be jumpered to activate the error memory.

Terminals **T1** and **T2** must be jumpered if no PTCs are used for monitoring the motor coil temperature.

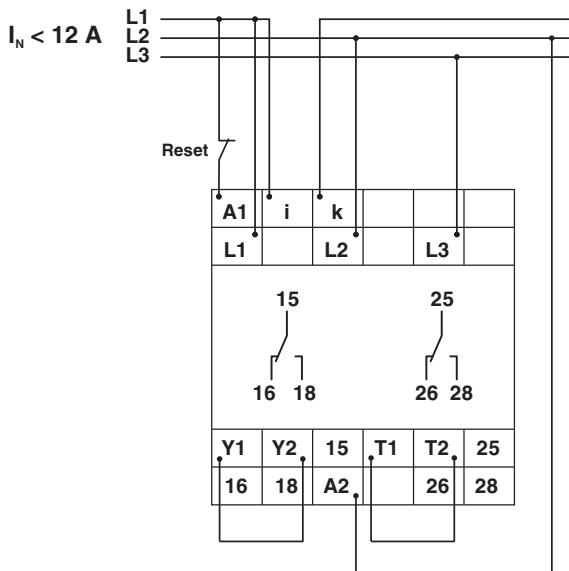

3~ 400 V connection with power module 400 V AC with error memory

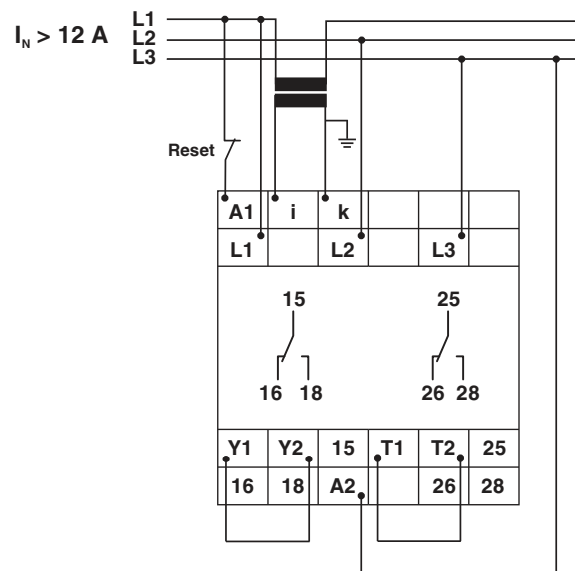

3~ 400 V connection with power module 400 V AC with error memory and current transformer

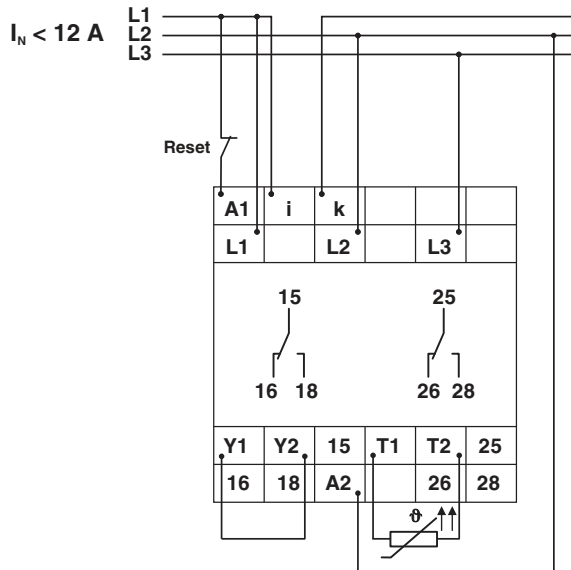

3~ 400 V connection with power module 400 V AC with error memory and motor coil temperature monitoring

11 Function

Active power detection in 1 and 3-phase networks with adjustable threshold values (P1 and P2), separately adjustable starting override and response delay, selectable error memory, temperature monitoring of the motor winding with a maximum of 6 PTCs, a reset button and the following functions that can be selected with the rotary switches:

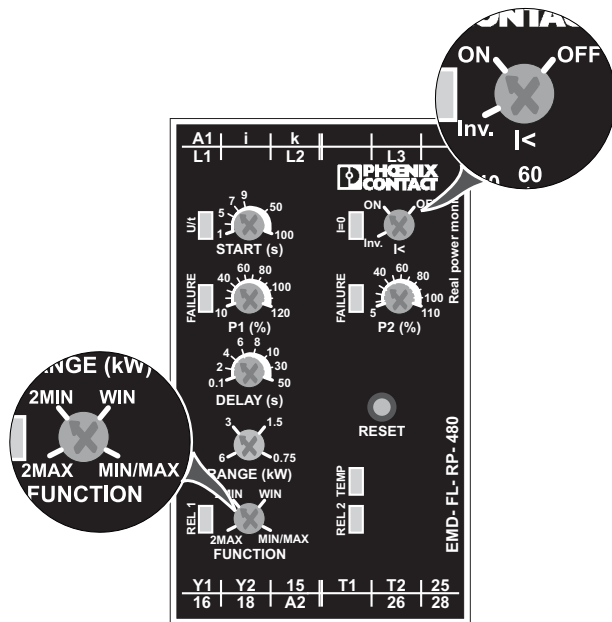

- **2MIN**
Minimum monitoring
- **2MIN+I< ON**
Minimum monitoring and recognition of disconnected consumers
- **2MIN+I< Inv.**
Minimum monitoring and recognition of disconnected consumers as error
- **2MAX**
Maximum monitoring
- **2MAX+I< ON**
Maximum monitoring and recognition of disconnected consumers as error
- **2MAX+I< Inv.**
Maximum monitoring and recognition of disconnected consumers
- **WIN**
Monitoring the range between MIN and MAX thresholds
- **WIN+I< ON**
Monitoring the range between MIN and MAX thresholds and recognition of disconnected consumers
- **WIN+I< Inv.**
Monitoring the range between MIN and MAX thresholds and recognition of disconnected consumers as error
- **MIN/MAX**
Minimum and maximum monitoring
- **MIN/MAX+I< ON**
Minimum and maximum monitoring and recognition of disconnected consumers
- **MIN/MAX+I< Inv.**
Minimum and maximum monitoring and recognition of disconnected consumers as error



When supply voltage U is applied, output relays Rel 1 and Rel 2 pick up (yellow "Rel 1" and "Rel 2" LEDs are ON) and the starting override (START) starts running (green "U/t" LED flashes). During the starting override, modifications to the measured active power have no influence on the position of output relays Rel 1 and Rel 2. Once the starting override has elapsed, the green "U/t" LED is ON.



Please take care that the "Range", "Function" and "I<" switches snap into the desired position.

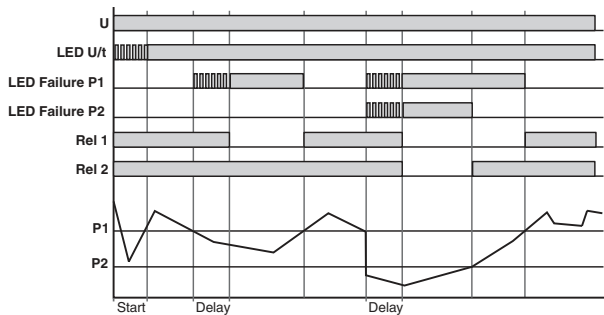

Minimum monitoring (2MIN)

The set threshold value for P1 must be greater than the value set for P2.

If the measured active power falls below the value set on the P1 controller, the response delay starts running (red "Failure" LED for threshold P1 flashes). After the delay time has elapsed (red "Failure" LED for threshold P1 is ON), output relay Rel 1 drops (yellow "Rel 1" LED is OFF). If the measured active power falls below the value set on the P2 controller, the response delay starts running again (red "Failure" LED for threshold P2 flashes). After the delay time has elapsed (red "Failure" LED for threshold P2 is ON), output relay Rel 2 drops (yellow "Rel 2" LED is OFF).

As soon as the measured active power exceeds the value set at the corresponding controller (P1 or P2) (red "Failure" LED for corresponding threshold P1 or P2 is OFF), output relays Rel 1 or Rel 2 pick up immediately (yellow "Rel 1" or "Rel 2" LED is ON).

Maximum monitoring (2MAX)

The set threshold value for P1 must be greater than the value set for P2.

If the measured active power exceeds the value set on the P2 controller, the response delay starts running (red "Failure" LED for threshold P2 flashes). After the delay time has elapsed (red "Failure" LED for threshold P2 is ON), output relay Rel 2 drops (yellow "Rel 2" LED is OFF). If the measured active power exceeds the value set on the P1 controller, the response delay starts running again (red "Failure" LED for threshold P1 flashes). After the delay time has elapsed (red "Failure" LED for threshold P1 is ON), output relay Rel 1 drops (yellow "Rel 1" LED is OFF).

As soon as the measured active power falls below the value set at the corresponding controller (P1 or P2) (red "Failure" LED for corresponding threshold P1 or P2 is OFF), the output relays Rel 1 or Rel 2 pick up immediately (yellow "Rel 1" or "Rel 2" LED is ON).

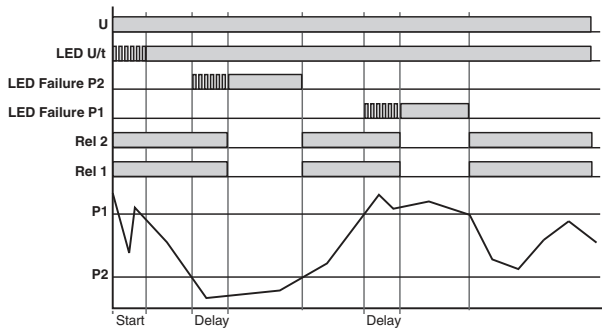

Window function (WIN)

The set threshold value for P1 must be greater than the value set for P2.

If the measured active power falls below the value set on the P2 controller, the response delay starts running (red "Failure" LED for threshold P2 flashes). After the delay time has elapsed (red "Failure" LED for threshold P2 is ON), output relays Rel 1 and Rel 2 drop (yellow "Rel 1" and "Rel 2" LEDs are OFF). As soon as the measured active power exceeds the value set at the P2 controller (red "Failure" LED for threshold P2 is OFF), the output relays Rel 1 or Rel 2 pick up immediately (yellow "Rel 1" and "Rel 2" LED are ON).

If the measured active power exceeds the value set on the P1 controller, the response delay starts running again (red "Failure" LED for threshold P1 flashes). After the delay time has elapsed (red "Failure" LED for threshold P1 is ON), output relays Rel 1 and Rel 2 drop (yellow "Rel 1" and "Rel 2" LEDs are OFF). As soon as the measured active power falls below the value set at the P1 controller (red "Failure" LED for threshold P1 is OFF), output relays Rel 1 or Rel 2 pick up immediately (yellow "Rel 1" and "Rel 2" LEDs are ON).

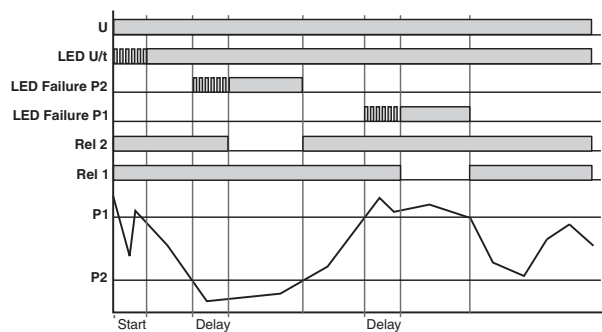

Minimum and maximum monitoring (MIN/MAX)

The set threshold value for P1 must be greater than the value set for P2.

If the measured active power falls below the value set on the P2 controller, the response delay starts running (red "Failure" LED for threshold P2 flashes). After the delay time has elapsed (red "Failure" LED for threshold P2 is ON), output relay Rel 2 drops (yellow "Rel 2" LED is OFF). As soon as the measured active power exceeds the value set at the P2 controller (red "Failure" LED for threshold P2 is OFF), output relay Rel 2 picks up immediately (yellow "Rel 2" LED is ON).

If the measured active power exceeds the value set on the P1 controller, the response delay starts running again (red "Failure" LED for threshold P1 flashes). After the delay time has elapsed (red "Failure" LED for threshold P1 is ON), output relay Rel 1 drops (yellow "Rel 1" LED is OFF). As soon as the measured active power falls below the value set at the P1 controller (red "Failure" LED for threshold P1 is OFF), output relay Rel 1 picks up immediately (yellow "Rel 1" LED is ON).

11.1 Error memory

The error memory can be activated with a jumper between terminals Y1 and Y2.

If the error memory has been activated and an error occurred (red "Failure" LED of the corresponding threshold or red "Temp" LED is on), the memory can only be reset by interrupting the power supply or pressing the reset button. Once the error has been reset the supply voltage is applied again, output relays "Rel 1" and "Rel 2" pick up and the measuring cycle starts again once the set starting override (START) has elapsed.



The error memory remains active in spite of an I< detection.

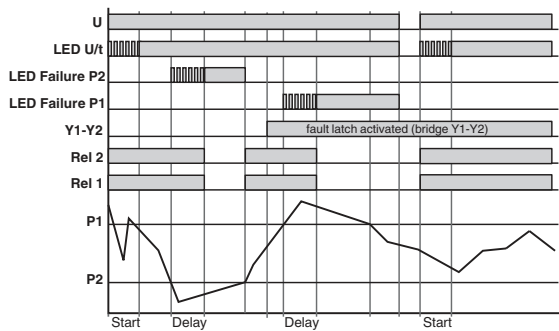

Example: Resetting the error memory with window function by interrupting the power supply

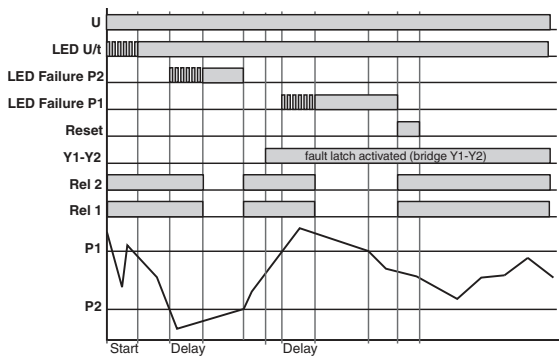

Example: Resetting the error memory with window function by pressing the reset button

11.2 Detecting switched off consumers

The following applies to functions for which I< detection (I< ON) is activated:

If the current flow is interrupted between i and k (yellow LED I=0 is ON) and if minimum, window, or minimum and maximum function (2MIN+I<, WIN+I<, MIN/MAX+I<) have been selected, output relays Rel 1 and Rel 2 remain picked up when the current flow is interrupted (yellow "Rel 1" and "Rel 2" LEDs are ON). However, if the maximum function (2MAX+I<) is selected, output relays Rel 1 and Rel 2 drop when the current is interrupted (yellow "Rel 1" and "Rel 2" LEDs are OFF).

When the current flows again, the measuring cycle starts again once the set starting override (START) has elapsed (green "U/t" LED flashing).

The following applies to functions for which inverted I< detection (I< Inv.) is activated:

When no current flows between i and k (yellow LED I=0 is ON), both relays respond inversely to the above function. If minimum, window, or minimum and maximum function (2MIN+I< Inv., WIN+I< Inv., MIN/MAX+I< Inv.) have been selected, output relays Rel 1 and Rel 2 drop when the current is interrupted (yellow "Rel 1" and "Rel 2" LEDs are OFF).

However, if the maximum function (2MAX+I< Inv.) is selected, output relays Rel 1 and Rel 2 remain picked up when the current is interrupted (yellow "Rel 1" and "Rel 2" LEDs are ON).

When the current flows again, the measuring cycle starts again once the set starting override (START) has elapsed (green "U/t" LED flashing).

I< with minimum monitoring (2MIN+I<)

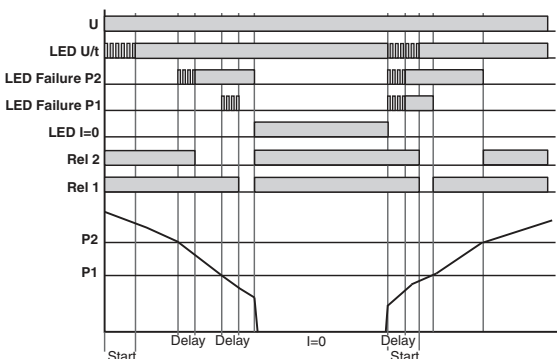

I< Inv. with minimum monitoring (2MIN+I< Inv.)

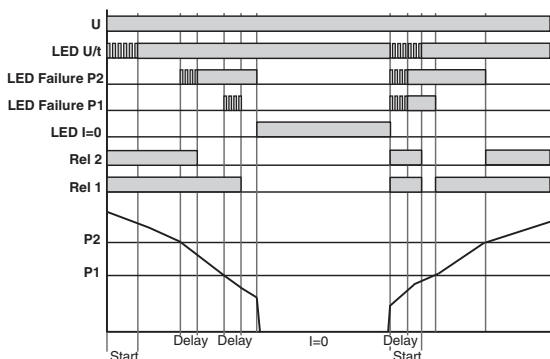

I< with maximum monitoring (2MAX+I<)

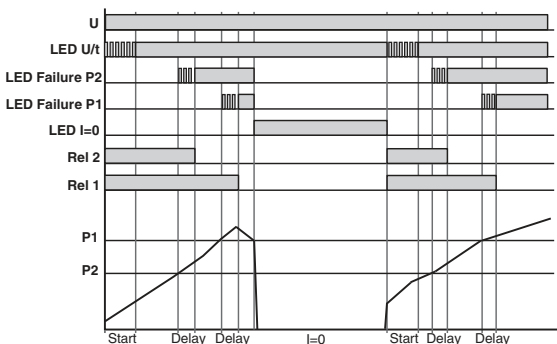

I< Inv. with maximum monitoring (2MIN+I< Inv.)

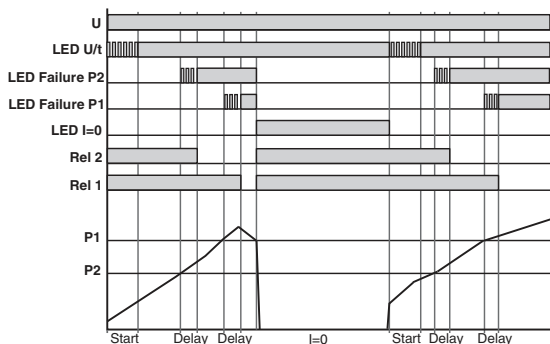

11.3 Temperature monitoring of the motor winding

If the PTC total resistance is less than $3.6\text{ k}\Omega$ (normal temperature of the motor) when the supply voltage is being applied (green U/t LED is ON), output relay Rel 2 picks up unless another error is present.

If the total resistance rises above $3.6\text{ k}\Omega$ (at least one of the PTCs has reached the nominal switch-off temperature), output relay Rel 2 drops out (yellow Rel 2 LED is OFF) and an error will be displayed (red "Temp" LED is ON). Output relay Rel 2 picks up again (yellow "Rel 2" LED is ON) or the error is deleted (red "Temp" LED is OFF), if the PTC total resistance has fallen below $1.8\text{ k}\Omega$ again once the PTC has cooled down. If the error memory has been activated and an error occurred (red "Temp" LED is ON), the memory can be reset by pressing the reset button.

Temperature monitoring without error memory

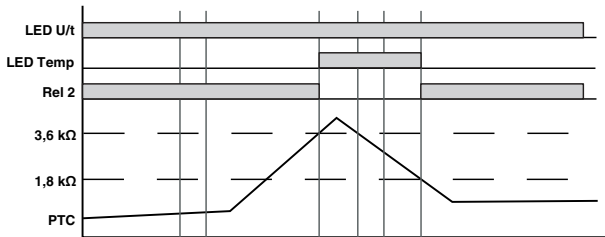

Temperature monitoring with error memory

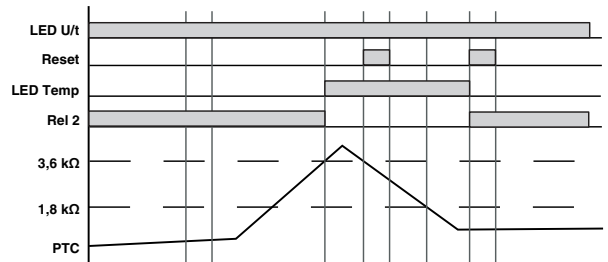

If output relay Rel 2 is to pick up again no other error must be present when the reset button is pressed.