

IS31I07326

DEBOUNCED 8×8 KEY-SCAN CONTROLLER

January 2012

GENERAL DESCRIPTION

The IS31I07326 is a 64 key, key-scan controller. It offloads the burden of keyboard scanning from the host processor. The IS31I07326 supports keypad matrix of up to 8×8. Key press and release events are encoded into a byte format and loaded into a key event register for retrieval by the host processor.

The IS31I07326 integrates a debounce function which rejects false or transient key switch activities. The interrupt output ($\overline{\text{INT}}$) is used to signify if there are any keypad activities.

To minimize power, the IS31I07326 automatically enters a low power standby mode when there is no keypad, I/O, or host activity.

The IS31I07326 is available in a Pb-free 4mm × 4mm QFN-24 package.

FEATURES

- 2.4V to 5.5V operation
- 400kHz I²C serial interface
- Available for multi-key press detect
- Low 0.3μA (typ.) standby current
- Operate in -40°C to +125°C
- Pb-free 4mm × 4mm QFN-24 package

APPLICATIONS

- Keypad of QWERTY type phones
- PDAs, games, and other handheld applications

TYPICAL APPLICATION CIRCUIT

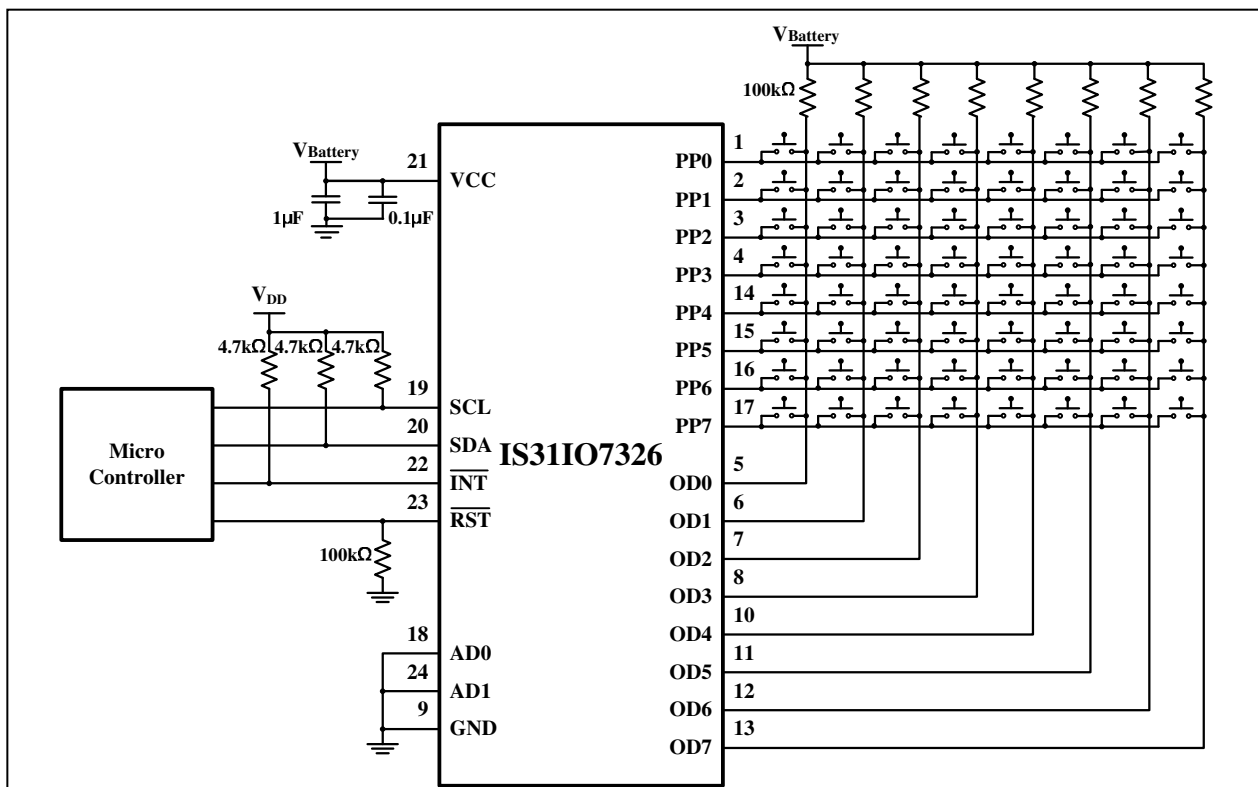
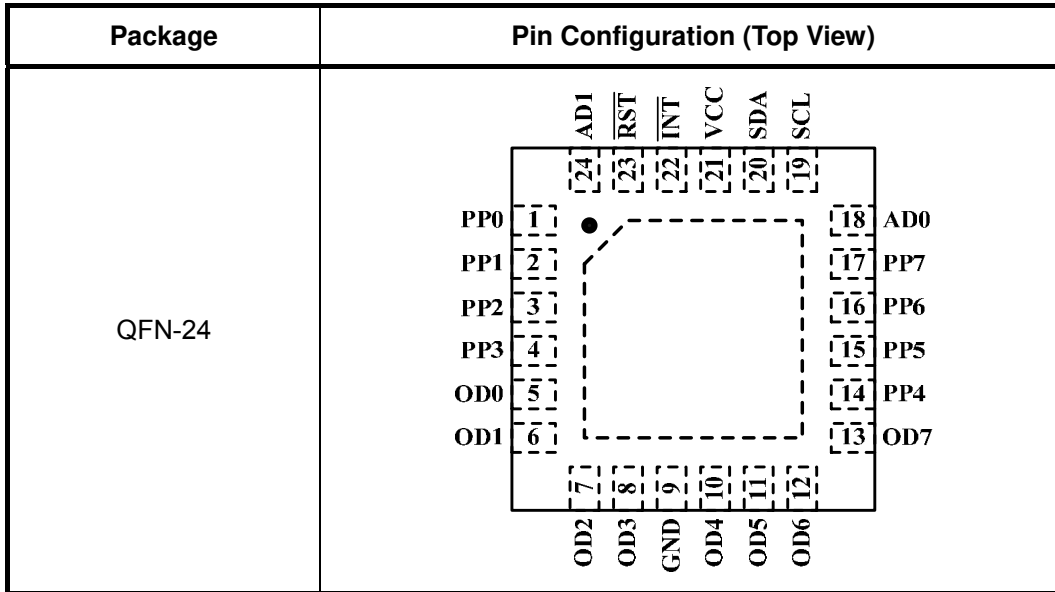

Figure 1 Typical Application Circuit

IS3107326

PIN CONFIGURATION



PIN DESCRIPTION

No.	Pin	Description
1~4, 14~17	PP0~PP7	Output ports.
5~8, 10~13	OD0~OD7	Input ports.
9	GND	Ground.
18	AD0	Address setting.
19	SCL	I2C serial clock.
20	SDA	I2C serial data.
21	VCC	Power supply voltage.
22	$\overline{\text{INT}}$	Interrupt output, active low.
23	$\overline{\text{RST}}$	Reset input, active low.
24	AD1	Address setting.
	Thermal Pad	Connect to GND.

IS31IO7326

ORDERING INFORMATION

Industrial Range: -40°C to +125°C

Order Part No.	Package	QTY/Reel
IS31IO7326-QFLS4-TR	QFN-24, Lead-free	2500

Copyright © 2011 Lumissil Microsystems. All rights reserved. Lumissil Microsystems reserves the right to make changes to this specification and its products at any time without notice. Lumissil Microsystems assumes no liability arising out of the application or use of any information, products or services described herein. Customers are advised to obtain the latest version of this device specification before relying on any published information and before placing orders for products.

Lumissil Microsystems does not recommend the use of any of its products in life support applications where the failure or malfunction of the product can reasonably be expected to cause failure of the life support system or to significantly affect its safety or effectiveness. Products are not authorized for use in such applications unless Lumissil Microsystems receives written assurance to its satisfaction, that:

- a.) the risk of injury or damage has been minimized;
- b.) the user assume all such risks; and
- c.) potential liability of Lumissil Microsystems is adequately protected under the circumstances

IS31IO7326

ABSOLUTE MAXIMUM RATINGS

Supply voltage, V_{CC}	-0.3V ~ +6.0V
Voltage at any input pin (Except PP0-PP7)	-0.3V ~ $V_{CC}+0.3V$
SCL, SDA, AD, RST, INT, OD0-OD3	-0.3V ~ +6.0V
PP0-PP3	-0.3V ~ $V_{CC}+0.3V$
PP source output current	$\pm 100mA$
PP/OD sink current	120mA
SDA sink current	10mA
INT sink current	10mA
Continuous power dissipation ($T_A = 70^\circ C$) 24-Pin QFN (Derate 33.2mW/ $^\circ C$ over $70^\circ C$)	2.65W
Maximum junction temperature, T_{JMAX}	+150 $^\circ C$
Storage temperature range, T_{STG}	-65 $^\circ C$ ~ +150 $^\circ C$
Operating temperature range, T_A	-40 $^\circ C$ ~ +125 $^\circ C$
Solder information, vapor phase (60s) infrared (15s)	215 $^\circ C$ 220 $^\circ C$
ESD HBM	$\pm 4kV$

Note: Stresses beyond those listed under "Absolute Maximum Ratings" may cause permanent damage to the device. These are stress ratings only and functional operation of the device at these or any other condition beyond those indicated in the operational sections of the specifications is not implied. Exposure to absolute maximum rating conditions for extended periods may affect device reliability.

ELECTRICAL CHARACTERISTICS

$T_A = -40^\circ C \sim +125^\circ C$, $V_{CC} = 2.4V \sim 5.5V$, unless otherwise noted. Typical values are at $T_A = 25^\circ C$, $V_{CC} = 3.3V$.

(Note 1)

Symbol	Parameter	Condition	Min.	Typ.	Max.	Units
V_{CC}	Supply voltage		2.4		5.5	V
V_{POR}	Power-on-reset voltage	V_{CC} falling			2.35	V
I_{STB}	Standby current (Interface idle)	SCL, SDA and other digital inputs at V_{CC}		0.3	1.9	μA
I_+	Supply current (Interface running)	$f_{SCL} = 400kHz$ other digital inputs at V_{CC}		6.5	25	μA
V_{IH}	Logic "1" input voltage		1.4			V
V_{IL}	Logic "0" input voltage				0.4	V
I_{IH}, I_{IL}	Input leakage current	SDA, SCL, AD0, AD1, RST, OD0~OD7 at V_{CC} or GND	-0.2		+0.2	μA
C_{IN}	Input capacitance SDA, SCL, AD0, AD1, RST, OD0~OD7, PP0~PP7	(Note 2)		10		pF
V_{OL}	Logic "0" output voltage PP0~PP7	$V_{CC} = 2.5V, I_{SINK} = 10mA$			200	mV
		$V_{CC} = 3.3V, I_{SINK} = 15mA$			240	
		$V_{CC} = 5.0V, I_{SINK} = 20mA$			250	
V_{OLINT}	Output low-voltage INT	$I_{SINK} = 5mA$			180	mV
t_{SCAN}	Time to scan key matrix completely	Configuration Register bit SD = 0		16		ms
		Configuration Register bit SD = 1		9		

IS31IO7326

TIMING CHARACTERISTICS

$T_A = -40^{\circ}\text{C} \sim +125^{\circ}\text{C}$, $V_{CC} = 2.4\text{V} \sim 5.5\text{V}$, unless otherwise noted. Typical values are at $T_A = 25^{\circ}\text{C}$, $V_{CC} = 3.3\text{V}$.

(Note 3)

Symbol	Parameter	Condition	Min.	Typ.	Max.	Units
f_{SCL}	Serial-clock frequency				400	kHz
t_{BUF}	Bus free time between a STOP and a START condition		1.3			μs
$t_{HD, STA}$	Hold time (repeated) START condition		0.6			μs
$t_{SU, STA}$	Repeated START condition setup time		0.6			μs
$t_{SU, STO}$	STOP condition setup time		0.6			μs
$t_{HD, DAT}$	Data hold time	(Note 3)			0.9	μs
$t_{SU, DAT}$	Data setup time		100			ns
t_{LOW}	SCL clock low period		1.3			μs
t_{HIGH}	SCL clock high period		0.7			μs
t_R	Rise time of both SDA and SCL signals, receiving	(Note 4)		$20 + 0.1C_b$	300	ns
t_F	Fall time of both SDA and SCL signals, receiving	(Note 4)		$20 + 0.1C_b$	300	ns
$t_{F, TX}$	Fall time of SDA transmitting	(Note 4)		$20 + 0.1C_b$	250	ns
t_{SP}	Pulse width of spike suppressed	(Note 5)		50		ns
C_b	Capacitive load for each bus line				400	pF
t_W	RST pulse width		500			ns
t_{RST}	RST rising to START condition setup time		1			μs

PORT AND INTERRUPT TIMING CHARACTERISTICS

$T = -40^{\circ}\text{C} \sim +125^{\circ}\text{C}$, $V_{CC} = 2.4\text{V} \sim 5.5\text{V}$, unless otherwise noted. Typical values are at $T_A = 25^{\circ}\text{C}$, $V_{CC} = 3.3\text{V}$

(Note 3)

Symbol	Parameter	Condition	Min.	Typ.	Max.	Units
t_{PV}	Port output data valid	$C_L \leq 100\text{pF}$			4	μs
t_{PSU}	Port input setup time	$C_L \leq 100\text{pF}$	0			μs
t_{PH}	Port input hold time	$C_L \leq 100\text{pF}$	4			μs
t_{IV}	$\overline{\text{INT}}$ input data valid time	$C_L \leq 100\text{pF}$			4	μs
t_{IR}	$\overline{\text{INT}}$ reset delay time from acknowledge	$C_L \leq 100\text{pF}$			4	μs

Note 1: All parameters are tested at $T_A = 25^{\circ}\text{C}$. Specifications over temperature are guaranteed by design.

Note 2: Guaranteed by design.

Note 3: A master device must provide a hold time of at least 300ns for the SDA signal (referred to VIL of the SCL signal) in order to bridge the undefined region of SCL's falling edge.

Note 4: C_b = total capacitance of one bus line in pF. $I_{SINK} \leq 6\text{mA}$. t_R and t_F measured between $0.3 \times V_{CC}$ and $0.7 \times V_{CC}$.

Note 5: Input filters on the SDA and SCL inputs suppress noise spikes less than 50ns.

IS31IO7326

DETAILED DESCRIPTION

I2C INTERFACE

The IS31IO7326 uses a serial bus, which conforms to the I2C protocol, to control the chip's functions with two wires: SCL and SDA. The IS31IO7326 has a 7-bit slave address (A7:A1), followed by the $\overline{R/W}$ bit, A0. Set A0 to "0" for a write command and set A0 to "1" for a read command. The bit A2:A1 are selected by the connection of AD1/AD0 pin.

The complete slave address is:

Table 1 Slave Address:

Bit	A7:A3	A2	A1	A0
Default	10110	AD1	AD0	0/1

AD1/AD0 connects to VCC, AD1/AD0=1;
 AD1/AD0 connects to GND, AD1/AD0=0;

The SCL line is uni-directional. The SDA line is bi-directional (open-collector) with a pull-up resistor (typically 4.7k Ω). The maximum clock frequency specified by the I2C standard is 400kHz. In this discussion, the master is the microcontroller and the slave is the IS31IO7326.

The timing diagram for the I2C is shown in Figure 3. The SDA is latched in on the stable high level of the SCL. When there is no interface activity, the SDA line should be held high.

The "START" signal is generated by lowering the SDA signal while the SCL signal is high (Figure 4). The start signal will alert all devices attached to the I2C bus to check the incoming address against their own chip address.

The 8-bit chip address is sent next, most significant bit first. Each address bit must be stable while the SCL level is high.

After the last bit of the chip address is sent, the master checks for the IS31IO7326's acknowledge. The master releases the SDA line high (through a pull-up resistor). Then the master sends an SCL pulse. If the IS31IO7326 has received the address correctly, then it holds the SDA line low during the SCL pulse. If the SDA line is not low, then the master should send a "STOP" signal (discussed later) and abort the transfer.

Following acknowledge of IS31IO7326, the register address byte is sent, most significant bit first. IS31IO7326 must generate another acknowledge indicating that the register address has been received.

An 8-bit data byte is sent next, most significant bit first. Each data bit should be valid while the SCL level is stable high. After the data byte is sent, the IS31IO7326 must generate another acknowledge to indicate that the data was received.

The "STOP" signal ends the transfer. To signal "STOP", the SDA signal goes high while the SCL signal is high (Figure 4).

WRITING TO THE REGISTERS

Transmit data to the IS31IO7326 by sending the device slave address and setting the LSB to "0". The command byte is sent after the address and determines which registers receive the data following the command byte (Figure 2).

READING PORT REGISTERS

To read the device data, the bus master must first send the IS31IO7326 address with the $\overline{R/W}$ bit set to "0", followed by the command byte, which determines which register is accessed. After a restart, the bus master must then send the IS31IO7326 address with the $\overline{R/W}$ bit set to "1". Data from the register defined by the command byte is then sent from the IS31IO7326 to the master (Figure 6).

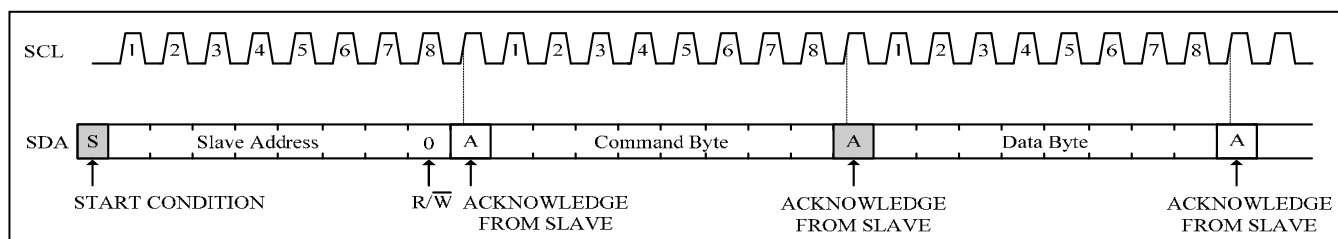

Figure 2 Writing to IS31IO7326

IS31107326

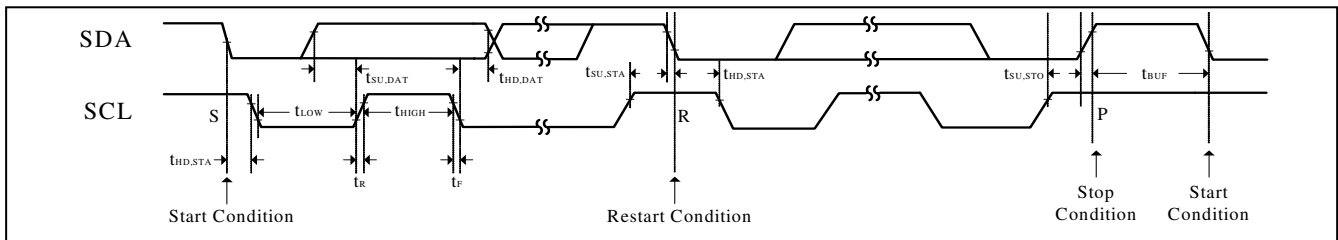

Figure 3 Interface Timing

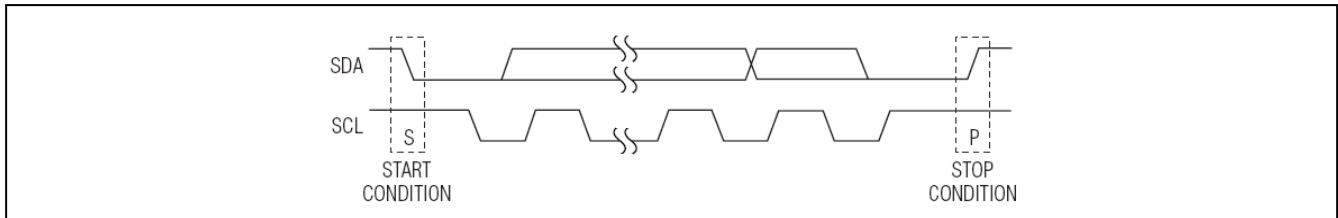

Figure 4 START and STOP Conditions

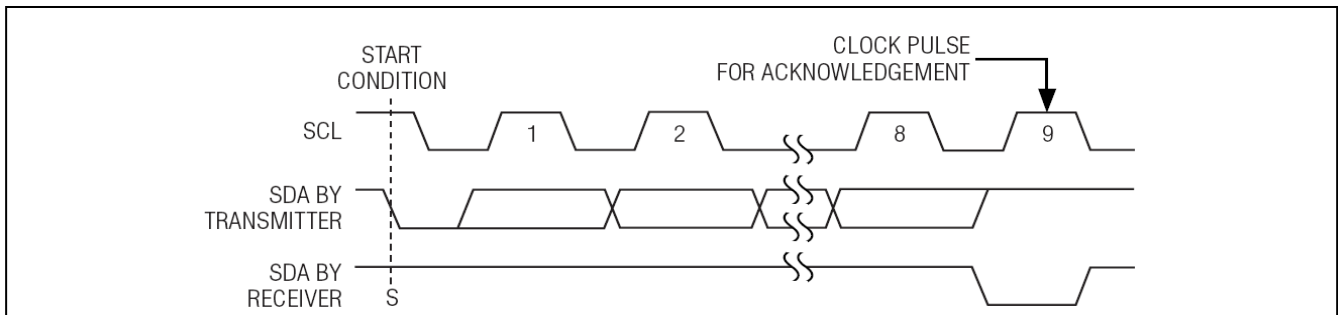

Figure 5 Acknowledge Signal

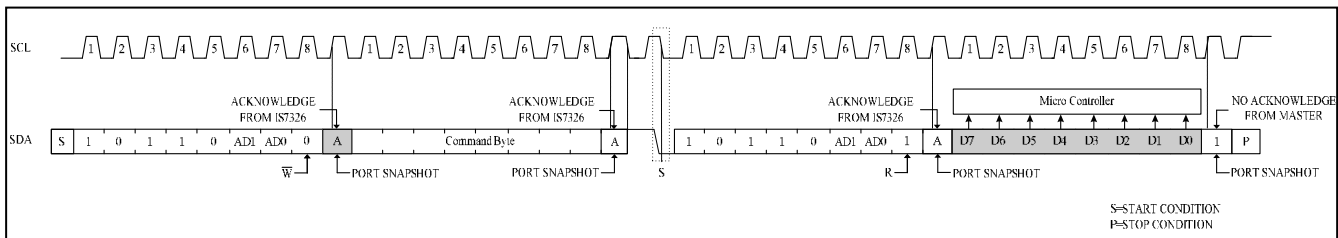

Figure 6 Reading I/O Ports of IS31107326

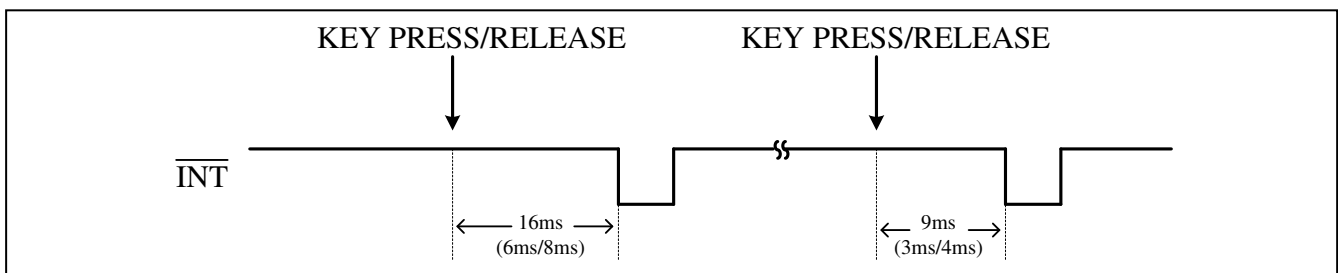

Figure 7 INT Timing

IS31IO7326

REGISTER DEFINITION

Table 2 Register Function

Address	Name	Function	Default	Table
08h	Configuration Register	Configure the keypad scan function	0001 0000	3
10h	Key Status Register	Contains the information of the key events	0000 0000	4

Table 3 08h Configuration Register

Bit	D7	D6:D5	D4	D3	D2	D1:D0
Name	Reserved	ACI	DE	SD	LE	LT
Default	0	00	1	0	0	00

The Configuration Register is used to configure the keypad scan function.

ACI	Auto Clear $\overline{\text{INT}}$
00	Auto clear $\overline{\text{INT}}$ disabled
01	Auto clear $\overline{\text{INT}}$ in 5ms
10	Auto clear $\overline{\text{INT}}$ in 10ms
DE	Input Port Filter Enable
0	Input port filter disable
1	Input port filter enable
SD	Key Scan Debounce Time
0	Double debounce time (6ms, 8ms)
1	Normal debounce time (3ms, 4ms)
LE	Long-pressed Key Detect Enable
0	Disable
1	Enable
LT	Long-pressed Key Detect Delay Time
00	20ms
01	40ms
10	1s
11	2s

Table 4 10h Key Status Register

Bit	D7	D6	D5:D0
Name	DN	KS	KM
Default	0	0	000000

The Key Status Register contains the information of the key events that have been debounced (see the Table 5 of the key mapping).

DN	Indicate Data Number
0	One key event to report
1	More than one key to report
KS	Key State
0	Key released
1	Key pressed
KM	Key Mapping

KM denotes which of the 64 keys have been debounced and the keys are numbered as shown in the Table 5.

When the Key Status Register is read over (DN=0), the register is set to "0000 0000", and the $\overline{\text{INT}}$ is cleared.

Table 5 Key Mapping (D5:D0)

	PP0	PP1	PP2	PP3	PP4	PP5	PP6	PP7
OD0	000000	000001	000010	000011	000100	000101	000110	000111
OD1	001000	001001	001010	001011	001100	001101	001110	001111
OD2	010000	010001	010010	010011	010100	010101	010110	010111
OD3	011000	011001	011010	011011	011100	011101	011110	011111
OD4	100000	100001	100010	100011	100100	100101	100110	100111
OD5	101000	101001	101010	101011	101100	101101	101110	101111
OD6	110000	110001	110010	110011	110100	110101	110110	110111
OD7	111000	111001	111010	111011	111100	111101	111110	111111

Examples

1. If the key PP1-OD3 pressed only, and other keys keep released state, the $\overline{\text{INT}}$ asserts, the data in Key Status Register would be "0101 1001";
2. If the key PP4-OD6 released only, and other keys keep released state, the $\overline{\text{INT}}$ asserts, the data in Key Status Register would be "0011 0100";
3. If the key PP2-OD4 and PP3-OD7 are pressing, then PP2-OD4 released, the $\overline{\text{INT}}$ asserts, the first data in Key Status Register would be "1010 0010", the second data would be "0111 1011". Then judge the MSB (bit DN) in the second data is "0". Data has read over, and $\overline{\text{INT}}$ goes to high.

We must read over the data in Key Status Register when the $\overline{\text{INT}}$ asserts. When judge the MSB (bit DN) in the data is "0", stop reading the Key Status Register. If there are some keys connected to the same OD port pressing at the same time, IS31IO7326 only can detect the first pressed key and others will ignore.

IS31IO7326

APPLICATION INFORMATION

INPUT AND OUTPUT PORT STRUCTURE

A 100kΩ pull-up resistor will force input port high at V_{Battery} .

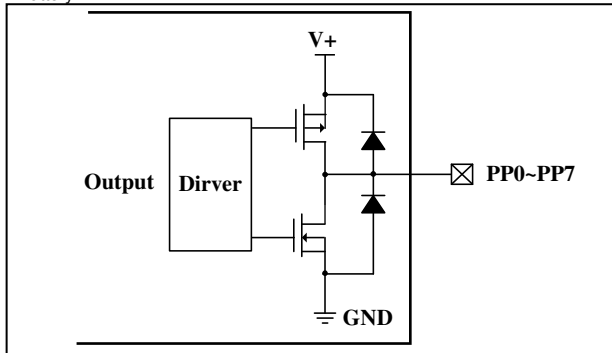

Figure 8 Output Port Structure

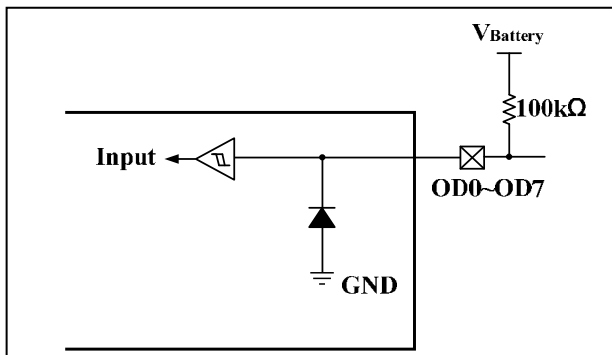

Figure 9 Input Port Structure

POWER-ON RESET

The IS31IO7326 contains an integral power-on-reset circuit that ensures all registers are reset to a known state on power-up. When V_{CC} rises above 2.4V, the circuit releases the registers and the I2C interface for normal operation. When V_{CC} drops to less than V_{POR} , the IS31IO7326 resets all register contents to the default value.

RST I2C RESET CONTROL

The active-low $\overline{\text{RST}}$ input voids any I2C transaction involving the IS31IO7326, forcing the IS31IO7326 into the I2C STOP condition. A reset does not affect the interrupt output.

STANDBY MODE

When the serial interface is idle, the IS31IO7326 automatically enters standby mode, drawing minimal supply current.

KEYPAD AUTO SCAN

The IS31IO7326 can support an 8×8 matrix keypad scan. The 8 input ports (OD ports) need a 100kΩ pull-up resistor for each column, the 8 output ports (PP ports) for the rows pull low in standby mode.

If a change of the state of the keypad is detected, the keypad would be scanned thrice between the debounce delay. When the state changes have been reliably captured, the key event(s) are encoded and written to temporary key status registers. The $\overline{\text{INT}}$ asserts when the key event(s) is (are) stored. Reading the Key Status Register reports the key events in the order of lowest encoding value to the highest (see Table 5). The $\overline{\text{INT}}$ will remain low until all of the key events are read, with one exception: When the Auto-Clear $\overline{\text{INT}}$ is enabled, if all of the key event data is not read before the programmed time, the $\overline{\text{INT}}$ will return high after the programmed time. However the temporary key status registers will remain unchanged and the key event data may continue to be read until another key event is detected.

DEBOUNCE

When the bit SD of the Configuration Register (08h) is set to "0" and there is a change of the state of the keypad, the keypad scans first and stores the data in temporary registers, then waits for about 6ms (3ms) and scans again, then waits for another 8ms (4ms) and scans a final time. If the results are the same, the data is latched into the temporary key status registers and the $\overline{\text{INT}}$ asserted. Otherwise, the scan is halted and the device returns to standby mode. No data is latched into the temporary key status registers and the $\overline{\text{INT}}$ is not asserted.

LONG-PRESSED KEY DETECT

When the bit LE of the Configuration Register (08h) is set to "0", this function is disabled. When LE is set to "1", this function is enabled. When a key is pressed for a long period of time, the chip automatically scans again after the $\overline{\text{INT}}$ is deasserted. When the key is still pressed, the $\overline{\text{INT}}$ asserts again and the key event is latched into the temporary key status registers. The scanning continues until all of the keys are released.

The delay time between the $\overline{\text{INT}}$ deasserting to the next scan beginning is set by the Configuration Register (08h) bits LT.

KEY EVENT INTERRUPT ($\overline{\text{INT}}$)

Once there is key event code latched in the temporary key status registers, the device produces an interrupt signal to the MCU on the $\overline{\text{INT}}$ pin. When the $\overline{\text{INT}}$ is asserted, any keypad state changes are ignored. The $\overline{\text{INT}}$ will remain low until all of the key events are read, with one exception: When the Auto-Clear $\overline{\text{INT}}$ is enabled, if all of the key event data is not read before the programmed time, the $\overline{\text{INT}}$ will return high after

IS31IO7326

the programmed time. However the temporary key status registers will remain unchanged and the key event data may continue to be read until another key event is detected. After all of the key events have been read, the device returns to standby mode waiting for the next scan.

AUTO-CLEAR $\overline{\text{INT}}$ FUNCTION

When the ACI bits of the Configuration Register (08h) are set to "01" or "10", this function is enabled. Setting the ACI bits to "00" disables the function. When enabled, the $\overline{\text{INT}}$ would be cleared in 5ms or 10ms after it asserts if there is no read of the Key Status Register. The data in the temporary key status registers does not change when the $\overline{\text{INT}}$ goes low. The Key Status Register can be read regardless of whether the $\overline{\text{INT}}$ is high or not. However, when the $\overline{\text{INT}}$ is cleared and there is new key event activity before the old key event data is read, the temporary key status registers are rewritten and the $\overline{\text{INT}}$ asserts again. In this case, the previous key event data is lost and only the new key event(s) can be read.

THE INPUT PORT FILTER

The bit DE of the Configuration Register (08h) is used to enable the input port filter. When DE is set to "0", the input port filter is disabled, and the chip responds to any changes at the input port. When DE is set to "1", the input port filter is enabled and any glitch shorter than 100ns is filtered. If the input pulse width is greater than 100ns, the chip responds (Figure 10).

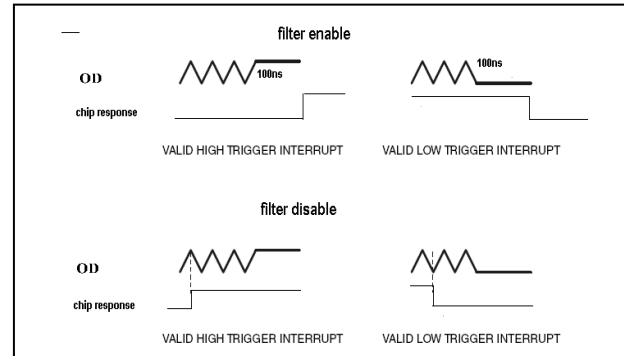

Figure 10 Input port debounce function

IS31107326

CLASSIFICATION REFLOW PROFILES

Profile Feature	Pb-Free Assembly
Preheat & Soak	
Temperature min (T _{smin})	150°C
Temperature max (T _{smax})	200°C
Time (T _{smin} to T _{smax}) (t _s)	60-120 seconds
Average ramp-up rate (T _{smax} to T _p)	3°C/second max.
Liquidous temperature (T _L)	217°C
Time at liquidous (t _L)	60-150 seconds
Peak package body temperature (T _p)*	Max 260°C
Time (t _p)** within 5°C of the specified classification temperature (T _c)	Max 30 seconds
Average ramp-down rate (T _p to T _{smax})	6°C/second max.
Time 25°C to peak temperature	8 minutes max.

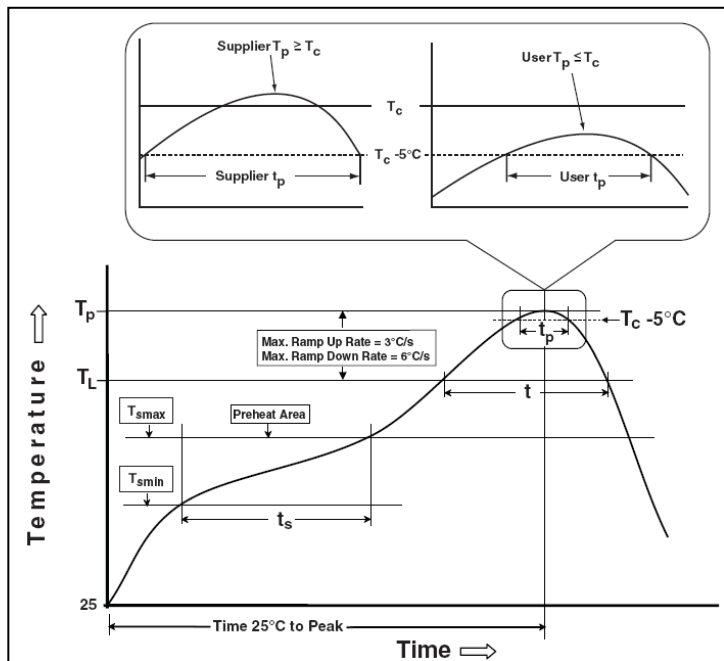
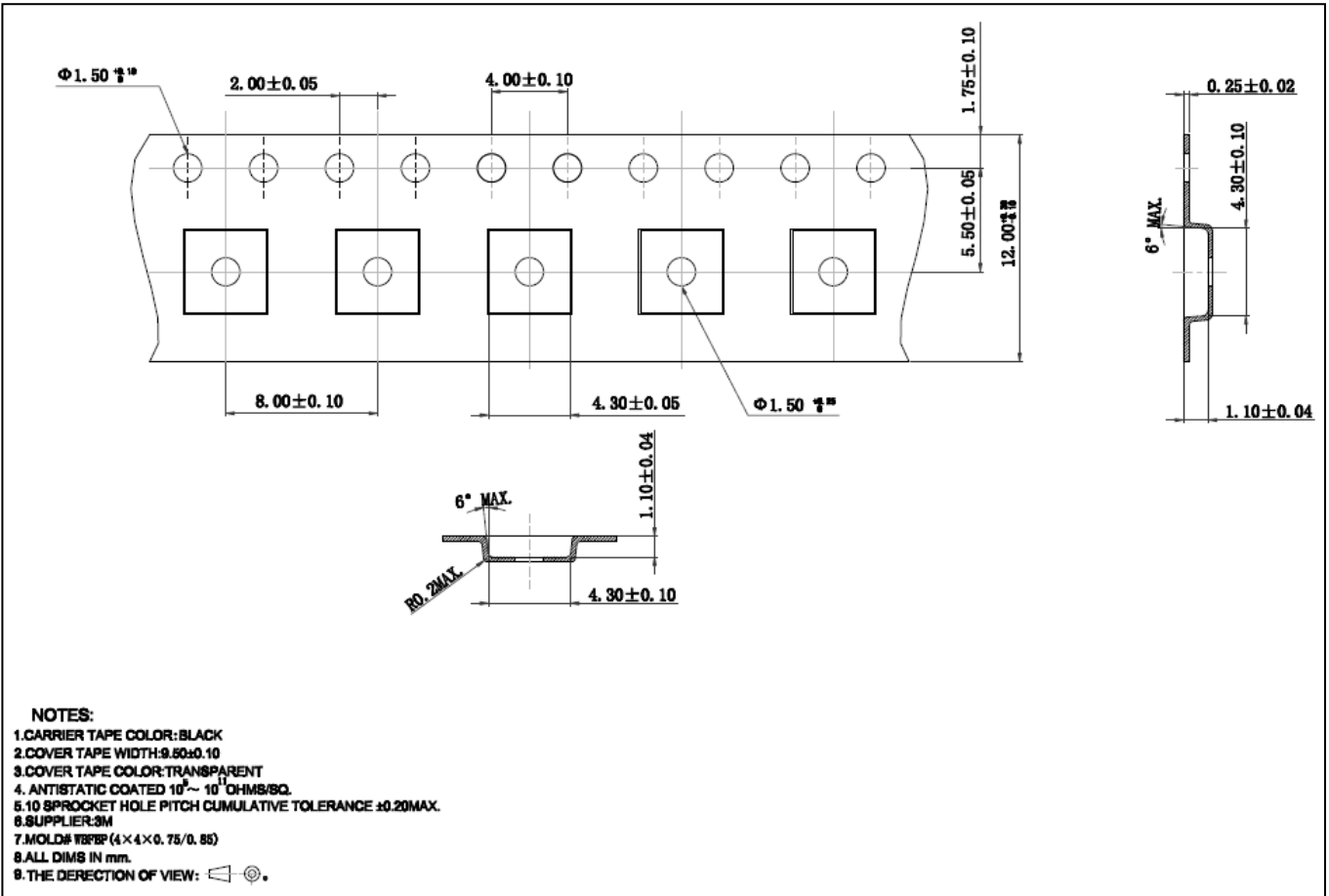

Figure 11 Classification profile

IS31IO7326

TAPE AND REEL INFORMATION



IS31IO7326

PACKAGE INFORMATION

QFN-24

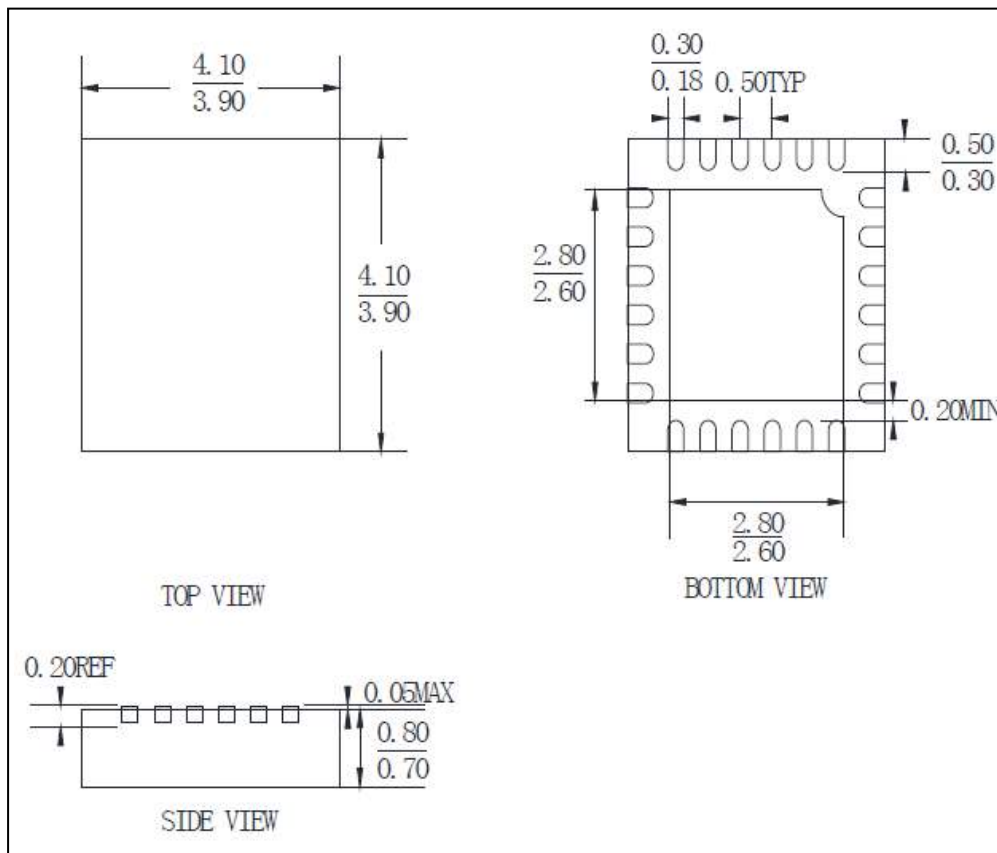

Note: All dimensions in millimeters unless otherwise stated.