

***±15kV ESD Protected, +3V to +5.5V,  
1Microamp, 250kbps, RS-232  
Transmitters/Receivers***

The Intersil ISL83220E is a 3.0V to 5.5V powered RS-232 transmitter/receiver which meets EIA/TIA-232 and V.28/V.24 specifications, even at  $V_{CC} = 3.0V$ . Additionally, it provides ±15kV ESD protection (IEC61000-4-2 Air Gap and Human Body Model) on transmitter outputs and receiver inputs (RS-232 pins). Targeted applications are PDAs, Palmtops, and notebook and laptop computers where the low operational, and even lower standby, power consumption is critical. Efficient on-chip charge pumps, coupled with a manual powerdown function, reduce the standby supply current to a 1µA trickle. Small footprint packaging, and the use of small, low value capacitors ensure board space savings as well. Data rates greater than 250kbps are guaranteed at worst case load conditions. This family is fully compatible with 3.3V only systems, mixed 3.3V and 5.0V systems, and 5.0V only systems.

Table 1 summarizes the features of the ISL83320E, while Application Note AN9863 summarizes the features of each device comprising the ICL32XXE 3V family.

**Features**

- Pb-Free Plus Anneal Available (RoHS Compliant)
- ESD Protection for RS-232 I/O Pins to ±15kV (IEC61000)
- Drop in Replacement for SP3220E
- Meets EIA/TIA-232 and V.28/V.24 Specifications at 3V
- RS-232 Compatible Outputs at 2.7V
- Latch-Up Free
- On-Chip Voltage Converters Require Only Four External 0.1µF Capacitors
- Manual Powerdown Feature with Receivers Active
- Separate Receiver Enable Pin
- $R_X$  and  $T_X$  Hysteresis For Improved Noise Immunity
- Guaranteed Minimum Data Rate . . . . . 250kbps
- Guaranteed Minimum Slew Rate . . . . . 6V/µs
- Wide Power Supply Range . . . . . Single +3V to +5.5V
- Low Supply Current in Powerdown State. . . . . 1µA

**Applications**

- Any System Requiring RS-232 Communication Ports
  - Battery Powered, Hand-Held, and Portable Equipment
  - Laptop Computers, Notebooks, Palmtops
  - Modems, Printers and other Peripherals
  - Digital Cameras
  - Cellular/Mobile Phones

**Related Literature**

- Technical Brief TB363 “Guidelines for Handling and Processing Moisture Sensitive Surface Mount Devices (SMDs)”

**TABLE 1. SUMMARY OF FEATURES**

<b>PART NUMBER</b>	<b>NO. OF Tx.</b>	<b>NO. OF Rx.</b>	<b>NO. OF MONITOR Rx. (R<sub>OUTB</sub>)</b>	<b>DATA RATE (kbps)</b>	<b>Rx. ENABLE FUNCTION?</b>	<b>READY OUTPUT?</b>	<b>MANUAL POWER-DOWN?</b>	<b>AUTOMATIC POWERDOWN FUNCTION?</b>
ISL83220E	1	1	0	250	Yes	No	Yes	No

**Pinout**

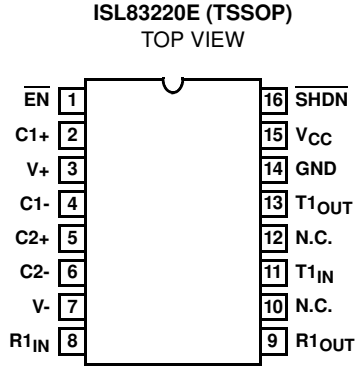

**Ordering Information**

PART NUMBER	PART MARKING	TEMP. RANGE (°C)	PACKAGE	PKG. DWG. #
ISL83220ECV	83220ECV	0 to 70	16 Ld TSSOP	M16.173
ISL83220ECV-T	83220ECV	0 to 70	16 Ld TSSOP Tape and Reel	M16.173
ISL83220ECVZ (See Note)	83220ECVZ	0 to 70	16 Ld TSSOP (Pb-Free)	M16.173
ISL83220ECVZ-T (See Note)	83220ECVZ	0 to 70	16 Ld TSSOP (Pb-Free) Tape and Reel	M16.173
ISL83220EIV	83220EIV	-40 to 85	16 Ld TSSOP	M16.173
ISL83220EIV-T	83220EIV	-40 to 85	16 Ld TSSOP Tape and Reel	M16.173
ISL83220EIVZ (See Note)	83220EIVZ	-40 to 85	16 Ld TSSOP (Pb-Free)	M16.173
ISL83220EIVZ-T (See Note)	83220EIVZ	-40 to 85	16 Ld TSSOP (Pb-Free) Tape and Reel	M16.173

NOTE: Intersil Pb-free plus anneal products employ special Pb-free material sets; molding compounds/die attach materials and 100% matte tin plate termination finish, which are RoHS compliant and compatible with both SnPb and Pb-free soldering operations. Intersil Pb-free products are MSL classified at Pb-free peak reflow temperatures that meet or exceed the Pb-free requirements of IPC/JEDEC J STD-020.

**Pin Descriptions**

PIN	FUNCTION
V <sub>CC</sub>	System power supply input (3.0V to 5.5V).
V <sub>+</sub>	Internally generated positive transmitter supply (+5.5V).
V <sub>-</sub>	Internally generated negative transmitter supply (-5.5V).
GND	Ground connection.
C1 <sub>+</sub>	External capacitor (voltage doubler) is connected to this lead.
C1 <sub>-</sub>	External capacitor (voltage doubler) is connected to this lead.
C2 <sub>+</sub>	External capacitor (voltage inverter) is connected to this lead.
C2 <sub>-</sub>	External capacitor (voltage inverter) is connected to this lead.
T <sub>IN</sub>	TTL/CMOS compatible transmitter Inputs.
T <sub>OUT</sub>	±15kV ESD Protected, RS-232 level (nominally ±5.5V) transmitter outputs.
R <sub>IN</sub>	±15kV ESD Protected, RS-232 compatible receiver inputs.
R <sub>OUT</sub>	TTL/CMOS level receiver outputs.
$\overline{\text{EN}}$	Active low receiver enable control; doesn't disable R <sub>OUTB</sub> outputs.
$\overline{\text{SHDN}}$	Active low input shuts down transmitters and on-board power supply, to place device in low power mode.
N.C.	No internal connection.

Typical Operating Circuit

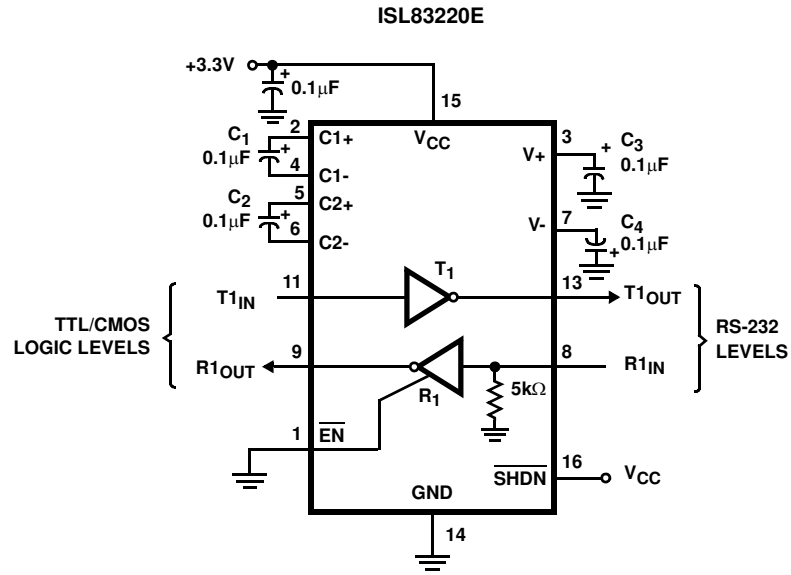

**Absolute Maximum Ratings**

V <sub>CC</sub> to Ground	-0.3V to 6V
V+ to Ground	-0.3V to 7V
V- to Ground	+0.3V to -7V
V+ to V-	14V
<b>Input Voltages</b>	
T <sub>IN</sub> , EN, SHDN	-0.3V to 6V
R <sub>IN</sub>	±25V
<b>Output Voltages</b>	
T <sub>OUT</sub>	±13.2V
R <sub>OUT</sub>	-0.3V to V <sub>CC</sub> +0.3V
Short Circuit Duration	
T <sub>OUT</sub>	Continuous
ESD Rating See Specification Table	

**Thermal Information**

Thermal Resistance (Typical, Note 1)	θ <sub>JA</sub> (°C/W)
16 Ld TSSOP Package	145
Maximum Junction Temperature (Plastic Package)	150°C
Maximum Storage Temperature Range	-65°C to 150°C
Maximum Lead Temperature (Soldering 10s) (Lead Tips Only)	300°C

**Operating Conditions**

Temperature Range	ISL83220ECV	0°C to 70°C
-------------------	-------------	-------------

CAUTION: Stresses above those listed in "Absolute Maximum Ratings" may cause permanent damage to the device. This is a stress only rating and operation of the device at these or any other conditions above those indicated in the operational sections of this specification is not implied.

NOTE:

1. θ<sub>JA</sub> is measured with the component mounted on a low effective thermal conductivity test board in free air. See Tech Brief TB379 for details.

**Electrical Specifications** Test Conditions: V<sub>CC</sub> = 3V to 5.5V, C<sub>1</sub> - C<sub>4</sub> = 0.1µF; Unless Otherwise Specified.  
Typicals are at T<sub>A</sub> = 25°C

PARAMETER	TEST CONDITIONS	TEMP (°C)	MIN	TYP	MAX	UNITS	
<b>DC CHARACTERISTICS</b>							
Supply Current	All Outputs Unloaded, SHDN = V <sub>CC</sub>	V <sub>CC</sub> = 3.15V	25	-	0.3	1.0 mA	
Supply Current, Powerdown	SHDN = GND		25	-	1.0	10 µA	
<b>LOGIC AND TRANSMITTER INPUTS AND RECEIVER OUTPUTS</b>							
Input Logic Threshold Low	T <sub>IN</sub> , EN, SHDN	Full	-	-	0.8	V	
Input Logic Threshold High	T <sub>IN</sub> , EN, SHDN	V <sub>CC</sub> = 3.3V	Full	2.0	-	-	V
		V <sub>CC</sub> = 5.0V	Full	2.4	-	-	V
Transmitter Input Hysteresis		25	-	0.3		V	
Input Leakage Current	T <sub>IN</sub> , EN, SHDN	Full	-	±0.01	±1.0	µA	
Output Leakage Current	EN = V <sub>CC</sub>	Full	-	±0.05	±10	µA	
Output Voltage Low	I <sub>OUT</sub> = 1.6mA	Full	-	-	0.4	V	
Output Voltage High	I <sub>OUT</sub> = -1.0mA	Full	V <sub>CC</sub> -0.6	V <sub>CC</sub> -0.1	-	V	
<b>TRANSMITTER OUTPUTS</b>							
Output Voltage Swing	All Transmitter Outputs Loaded with 3kΩ to Ground	Full	±5.0	±5.4	-	V	
Output Resistance	V <sub>CC</sub> = V+ = V- = 0V, Transmitter Output = ±2V	Full	300	10M	-	Ω	
Output Short-Circuit Current	V <sub>OUT</sub> = 0V	Full	-	±35	±60	mA	
Output Leakage Current	V <sub>OUT</sub> = ±12V, V <sub>CC</sub> = 0V or 3V to 5.5V, SHDN = GND	Full	-	-	±25	µA	
<b>RECEIVER INPUTS</b>							
Input Voltage Range		Full	-25	-	25	V	
Input Threshold Low	V <sub>CC</sub> = 3.3V	Full	0.6	1.2	-	V	
	V <sub>CC</sub> = 5.0V	Full	0.8	1.5	-	V	
Input Threshold High	V <sub>CC</sub> = 3.3V	Full	-	1.5	2.4	V	
	V <sub>CC</sub> = 5.0V	Full	-	1.8	2.4	V	
Input Hysteresis		25	-	0.3	-	V	
Input Resistance		Full	3	5	7	kΩ	

**Electrical Specifications** Test Conditions:  $V_{CC} = 3V$  to  $5.5V$ ,  $C_1 - C_4 = 0.1\mu F$ ; Unless Otherwise Specified.  
Typicals are at  $T_A = 25^\circ C$  (Continued)

PARAMETER	TEST CONDITIONS	TEMP (°C)	MIN	TYP	MAX	UNITS	
<b>TIMING CHARACTERISTICS</b>							
Maximum Data Rate	$R_L = 3k\Omega$ , $C_L = 1000pF$ , One Transmitter Switching	Full	250	500	-	kbps	
Transmitter Propagation Delay	Transmitter Input to Transmitter Output, $R_L = 3k\Omega$ , $C_L = 1000pF$	$t_{PHL}$	25	-	1.0	$\mu s$	
		$t_{PLH}$	25	-	1.0	$\mu s$	
Receiver Propagation Delay	Receiver Input to Receiver Output, $C_L = 150pF$	$t_{PHL}$	25	-	0.20	$\mu s$	
		$t_{PLH}$	25	-	0.30	$\mu s$	
Receiver Output Enable Time	Normal Operation	25	-	200	-	ns	
Receiver Output Disable Time	Normal Operation	25	-	200	-	ns	
Transmitter Skew	$t_{PHL} - t_{PLH}$ (Note 2)	25	-	100	500	ns	
Receiver Skew	$t_{PHL} - t_{PLH}$	Full	-	100	1000	ns	
Transition Region Slew Rate	$V_{CC} = 3.3V$ , $R_L = 3k\Omega$ to $7k\Omega$ , Measured From $3V$ to $-3V$ or $-3V$ to $3V$	$C_L = 150pF$ to $2500pF$	25	4	-	30	$V/\mu s$
		$C_L = 150pF$ to $1000pF$	25	6	-	30	$V/\mu s$
<b>ESD PERFORMANCE</b>							
RS-232 Pins ( $T_{OUT}$ , $R_{IN}$ )	Human Body Model	25	-	$\pm 15$	-	kV	
	IEC61000-4-2 Contact Discharge	25	-	$\pm 8$	-	kV	
	IEC61000-4-2 Air Gap Discharge	25	-	$\pm 15$	-	kV	
All Other Pins	Human Body Model	25	-	$\pm 3$	-	kV	

NOTE:

- Transmitter skew is measured at the transmitter zero crossing points.

## Detailed Description

The ISL83220E operates from a single +3V to +5.5V supply, guarantees a 250kbps minimum data rate, requires only four small external  $0.1\mu F$  capacitors, features low power consumption, and meets all EIA RS-232C and V.28 specifications. The circuit is divided into three sections: The charge pump, the transmitter, and the receiver.

### Charge-Pump

Intersil's new 3.3V family utilizes regulated on-chip dual charge pumps as voltage doublers, and voltage inverters to generate  $\pm 5.5V$  transmitter supplies from a  $V_{CC}$  supply as low as 3.0V. This allows these devices to maintain RS-232 compliant output levels over the  $\pm 10\%$  tolerance range of 3.3V powered systems. The efficient on-chip power supplies require only four small, external  $0.1\mu F$  capacitors for the voltage doubler and inverter functions, even at  $V_{CC} = 3.3V$ . The charge pumps operate discontinuously (i.e., they turn off as soon as the  $V_+$  and  $V_-$  supplies are pumped up to the nominal values), resulting in significant power savings.

### Transmitters

The transmitters are proprietary, low dropout, inverting drivers that translate TTL/CMOS inputs to EIA/TIA-232 output levels. Coupled with the on-chip  $\pm 5.5V$  supplies,

these transmitters deliver true RS-232 levels over a wide range of single supply system voltages.

The transmitter output disables and assumes a high impedance state when the device enters the powerdown mode (see Table 2). This output may be driven to  $\pm 12V$  when disabled.

All devices guarantee a 250kbps data rate for full load conditions ( $3k\Omega$  and  $1000pF$ ),  $V_{CC} \geq 3.0V$ . Under more typical conditions of  $V_{CC} \geq 3.3V$ ,  $R_L = 3k\Omega$ , and  $C_L = 250pF$ , the ISL83220E easily operates at 900kbps.

Transmitter inputs float if left unconnected, and may cause  $I_{CC}$  increases.

### Receivers

The ISL83220E device contains a standard inverting receiver that three-states via the  $\overline{EN}$  control line. Receivers convert RS-232 signals to CMOS output levels and accept inputs up to  $\pm 25V$  while presenting the required  $3k\Omega$  to  $7k\Omega$  input impedance (see Figure 1) even if the power is off ( $V_{CC} = 0V$ ). The receiver's Schmitt trigger input stage uses hysteresis to increase noise immunity and decrease errors due to slow input signal transitions.

The ISL83220E receiver disables only when  $\overline{\text{EN}}$  is driven high. (see Table 2). This allows the receiver to monitor external devices, like a modem, even when the ISL83220E is in its  $1\mu\text{A}$  powerdown state.

Standard receivers driving powered down peripherals must be disabled to prevent current flow through the peripheral's protection diodes (see Figure 2). This renders them useless for wake up functions.

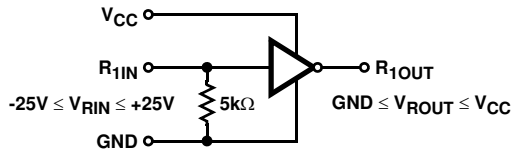

FIGURE 1. INVERTING RECEIVER CONNECTIONS

### Operation Down to 2.7V

ISL83220E transmitter outputs meet RS-562 levels ( $\pm 3.7\text{V}$ ), at the full data rate, with  $V_{\text{CC}}$  as low as 2.7V. RS-562 levels typically ensure interoperability with RS-232 devices.

### Powerdown Functionality

This 3V family of RS-232 interface devices requires a nominal supply current of 0.3mA during normal operation (not in powerdown mode), which is considerably less than the 5mA to 11mA current required of 5V RS-232 devices. The already low current requirement drops significantly when the device enters powerdown mode. In powerdown, supply current drops to  $1\mu\text{A}$ , because the on-chip charge pump turns off ( $V_+$  collapses to  $V_{\text{CC}}$ ,  $V_-$  collapses to GND), and the transmitter outputs three-state. This micro-power mode makes these devices ideal for battery powered and portable applications.

### Software Controlled (Manual) Powerdown

On the ISL83220E, the powerdown control is via a simple shutdown ( $\overline{\text{SHDN}}$ ) pin. Driving this pin high enables normal operation, while driving it low forces the IC into its powerdown state. Connect  $\overline{\text{SHDN}}$  to  $V_{\text{CC}}$  if the powerdown function isn't needed. Note that the receiver output remains enabled during shutdown (see Table 2). For the lowest power consumption during powerdown, the receiver should also be disabled by driving the  $\overline{\text{EN}}$  input high (see next section). The time to recover from manual powerdown mode is typically  $100\mu\text{s}$ .

TABLE 2. POWERDOWN AND ENABLE LOGIC TRUTH TABLE

$\overline{\text{SHDN}}$ INPUT	$\overline{\text{EN}}$ INPUT	TRANSMITTER OUTPUT	RECEIVER OUTPUT	MODE OF OPERATION
L	L	High-Z	Active	Manual Powerdown
L	H	High-Z	High-Z	Manual Powerdown w/Rcvr. Disabled
H	L	Active	Active	Normal Operation
H	H	Active	High-Z	Normal Operation w/Rcvr. Disabled

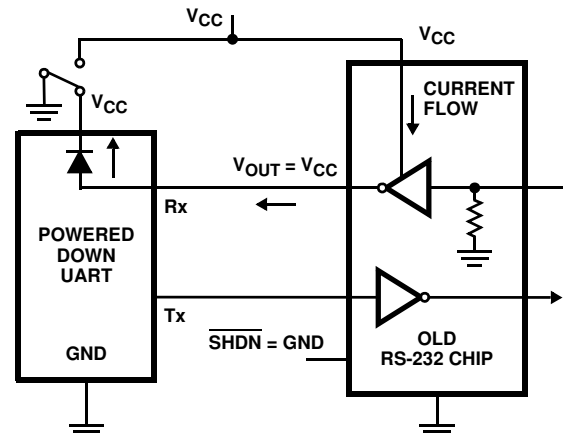

FIGURE 2. POWER DRAIN THROUGH POWERED DOWN PERIPHERAL

### Receiver ENABLE Control

The ISL83220E also features an  $\overline{\text{EN}}$  input to control the receiver output. Driving  $\overline{\text{EN}}$  high disables the receiver output placing it in a high impedance state. This is useful to eliminate supply current, due to a receiver output forward biasing the protection diode, when driving the input of a powered down ( $V_{\text{CC}} = \text{GND}$ ) peripheral (see Figure 2).

### Capacitor Selection

The charge pumps require  $0.1\mu\text{F}$  capacitors for 3.3V operation. Do not use values smaller than  $0.1\mu\text{F}$ . Increasing the capacitor values (by a factor of 2) reduces ripple on the transmitter outputs and slightly reduces power consumption. When using minimum required capacitor values, make sure that capacitor values do not degrade excessively with temperature. If in doubt, use capacitors with a larger nominal value. The capacitor's equivalent series resistance (ESR) usually rises at low temperatures and it influences the amount of ripple on  $V_+$  and  $V_-$ .

### Power Supply Decoupling

In most circumstances a  $0.1\mu\text{F}$  bypass capacitor is adequate. In applications that are particularly sensitive to power supply noise, decouple  $V_{\text{CC}}$  to ground with a capacitor of the same value as the charge-pump capacitor  $C_1$ . Connect the bypass capacitor as close as possible to the IC.

### Transmitter Output when Exiting Powerdown

Figure 3 shows the response of the transmitter output when exiting powerdown mode. As it activates, the transmitter output properly goes to RS-232 levels, with no glitching, ringing, nor undesirable transients. The transmitter is loaded with 3kΩ in parallel with 250pF. Note that the transmitter enables only when the magnitude of the supplies exceed approximately 3V.

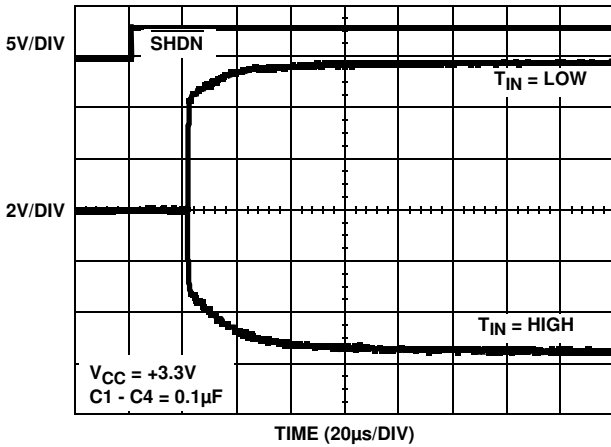

FIGURE 3. TRANSMITTER OUTPUT WHEN EXITING POWERDOWN

### High Data Rates

The ISL83220E maintains the RS-232 ±5V minimum transmitter output voltages even at high data rates. Figure 4 details a transmitter loopback test circuit, and Figure 5 illustrates the loopback test result at 120kbps. For this test, the transmitter is driving an RS-232 load in parallel with 1000pF, at 120kbps. Figure 6 shows the loopback results for the transmitter driving 1000pF and an RS-232 load at 250kbps.

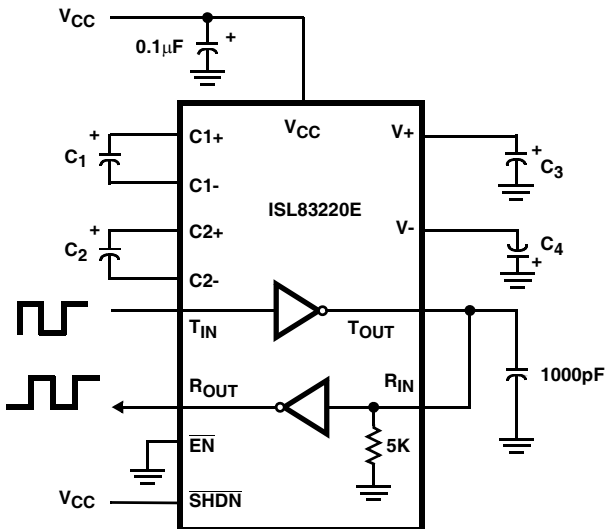

FIGURE 4. TRANSMITTER LOOPBACK TEST CIRCUIT

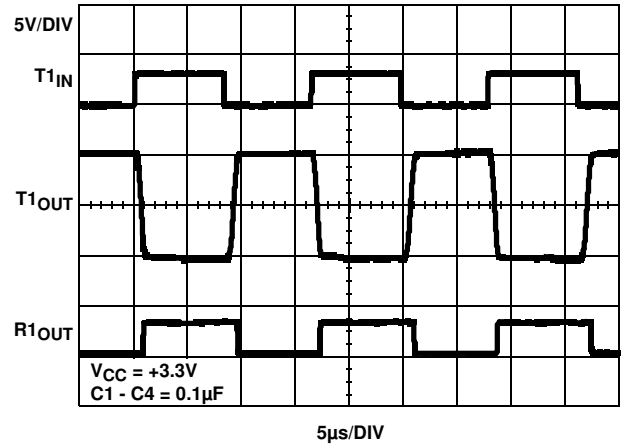

FIGURE 5. LOOPBACK TEST AT 120kbps

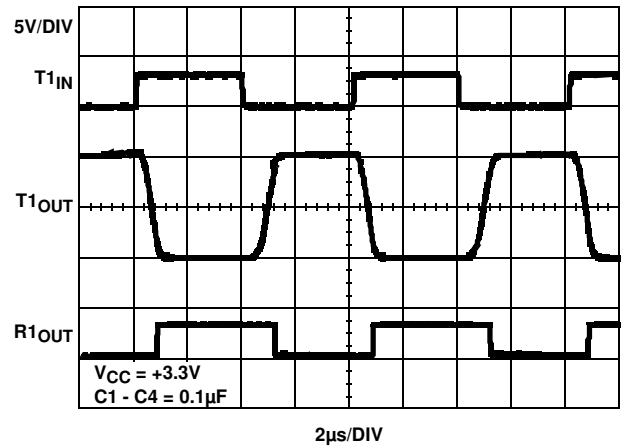

FIGURE 6. LOOPBACK TEST AT 250kbps

### Interconnection with 3V and 5V Logic

The ISL83220E directly interfaces with 5V CMOS and TTL logic families. Nevertheless, with the device at 3.3V, and the logic supply at 5V, AC, HC, and CD4000 outputs can drive ISL83220E inputs, but ISL83220E outputs do not reach the minimum  $V_{IH}$  for these logic families. See Table 4 for more information.

**TABLE 3. LOGIC FAMILY COMPATIBILITY WITH VARIOUS SUPPLY VOLTAGES**

SYSTEM POWER-SUPPLY VOLTAGE (V)	V <sub>CC</sub> SUPPLY VOLTAGE (V)	COMPATIBILITY
3.3	3.3	Compatible with all CMOS families.
5	5	Compatible with all TTL and CMOS logic families.
5	3.3	Compatible with ACT and HCT CMOS, and with TTL. ISL83220E outputs are incompatible with AC, HC, and CD4000 CMOS inputs.

**±15kV ESD Protection**

All pins on ISL8XXX devices include ESD protection structures, but the ISL8XXXE family incorporates advanced structures which allow the RS-232 pins (transmitter outputs and receiver inputs) to survive ESD events up to ±15kV. The RS-232 pins are particularly vulnerable to ESD damage because they typically connect to an exposed port on the exterior of the finished product. Simply touching the port pins, or connecting a cable, can cause an ESD event that might destroy unprotected ICs. These new ESD structures protect the device whether or not it is powered up, protect without allowing any latchup mechanism to activate, and don't interfere with RS-232 signals as large as ±25V.

**Human Body Model (HBM) Testing**

As the name implies, this test method emulates the ESD event delivered to an IC during human handling. The tester delivers the charge through a 1.5kΩ current limiting resistor, making the test less severe than the IEC61000 test which utilizes a 330Ω limiting resistor. The HBM method

determines an IC's ability to withstand the ESD transients typically present during handling and manufacturing. Due to the random nature of these events, each pin is tested with respect to all other pins. The RS-232 pins on "E" family devices can withstand HBM ESD events to ±15kV.

**IEC61000-4-2 Testing**

The IEC61000 test method applies to finished equipment, rather than to an individual IC. Therefore, the pins most likely to suffer an ESD event are those that are exposed to the outside world (the RS-232 pins in this case), and the IC is tested in its typical application configuration (power applied) rather than testing each pin-to-pin combination. The lower current limiting resistor coupled with the larger charge storage capacitor yields a test that is much more severe than the HBM test. The extra ESD protection built into this device's RS-232 pins allows the design of equipment meeting level 4 criteria without the need for additional board level protection on the RS-232 port.

**AIR-GAP DISCHARGE TEST METHOD**

For this test method, a charged probe tip moves toward the IC pin until the voltage arcs to it. The current waveform delivered to the IC pin depends on approach speed, humidity, temperature, etc., so it is difficult to obtain repeatable results. The "E" device RS-232 pins withstand ±15kV air-gap discharges.

**CONTACT DISCHARGE TEST METHOD**

During the contact discharge test, the probe contacts the tested pin before the probe tip is energized, thereby eliminating the variables associated with the air-gap discharge. The result is a more repeatable and predictable test, but equipment limits prevent testing devices at voltages higher than ±8kV. All "E" family devices survive ±8kV contact discharges on the RS-232 pins.

**Typical Performance Curves** V<sub>CC</sub> = 3.3V, T<sub>A</sub> = 25°C

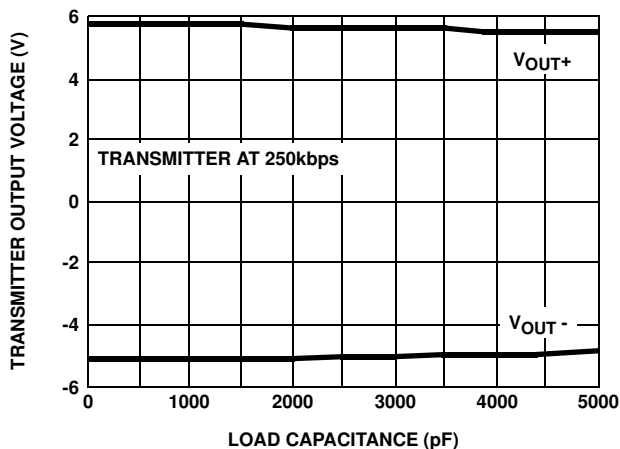

**FIGURE 7. TRANSMITTER OUTPUT VOLTAGE vs LOAD CAPACITANCE**

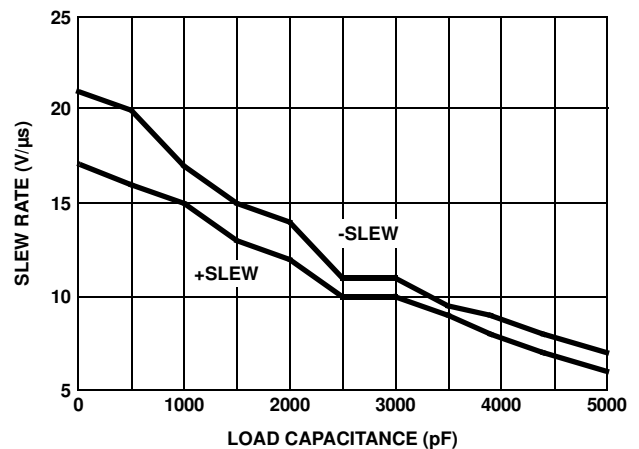

**FIGURE 8. SLEW RATE vs LOAD CAPACITANCE**



**Typical Performance Curves**  $V_{CC} = 3.3V, T_A = 25^\circ C$  (Continued)

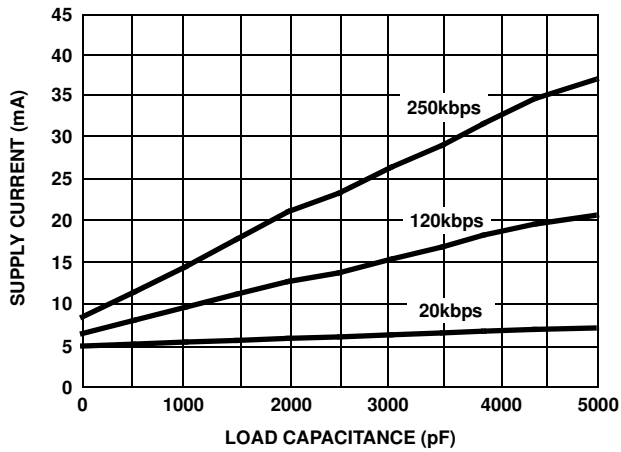

FIGURE 9. SUPPLY CURRENT vs LOAD CAPACITANCE WHEN TRANSMITTING DATA

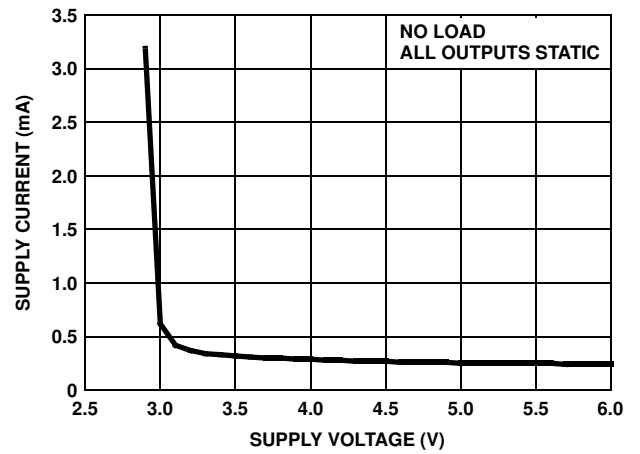

FIGURE 10. SUPPLY CURRENT vs SUPPLY VOLTAGE

**Die Characteristics**

**SUBSTRATE POTENTIAL (POWERED UP):**

GND

**TRANSISTOR COUNT:**

286

**PROCESS:**

Si Gate CMOS

Thin Shrink Small Outline Plastic Packages (TSSOP)

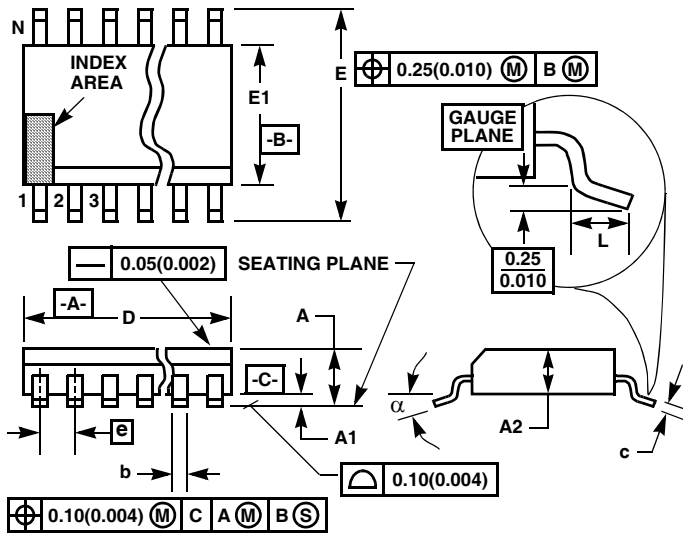

M16.173  
16 LEAD THIN SHRINK SMALL OUTLINE PLASTIC PACKAGE

SYMBOL	INCHES		MILLIMETERS		NOTES
	MIN	MAX	MIN	MAX	
A	-	0.043	-	1.10	-
A1	0.002	0.006	0.05	0.15	-
A2	0.033	0.037	0.85	0.95	-
b	0.0075	0.012	0.19	0.30	9
c	0.0035	0.008	0.09	0.20	-
D	0.193	0.201	4.90	5.10	3
E1	0.169	0.177	4.30	4.50	4
e	0.026 BSC		0.65 BSC		-
E	0.246	0.256	6.25	6.50	-
L	0.020	0.028	0.50	0.70	6
N	16		16		7
α	0°	8°	0°	8°	-

NOTES:

1. These package dimensions are within allowable dimensions of JEDEC MO-153-AB, Issue E.
2. Dimensioning and tolerancing per ANSI Y14.5M-1982.
3. Dimension "D" does not include mold flash, protrusions or gate burrs. Mold flash, protrusion and gate burrs shall not exceed 0.15mm (0.006 inch) per side.
4. Dimension "E1" does not include interlead flash or protrusions. Interlead flash and protrusions shall not exceed 0.15mm (0.006 inch) per side.
5. The chamfer on the body is optional. If it is not present, a visual index feature must be located within the crosshatched area.
6. "L" is the length of terminal for soldering to a substrate.
7. "N" is the number of terminal positions.
8. Terminal numbers are shown for reference only.
9. Dimension "b" does not include dambar protrusion. Allowable dambar protrusion shall be 0.08mm (0.003 inch) total in excess of "b" dimension at maximum material condition. Minimum space between protrusion and adjacent lead is 0.07mm (0.0027 inch).
10. Controlling dimension: MILLIMETER. Converted inch dimensions are not necessarily exact. (Angles in degrees)

Rev. 1 2/02

All Intersil U.S. products are manufactured, assembled and tested utilizing ISO9000 quality systems. Intersil Corporation's quality certifications can be viewed at [www.intersil.com/design/quality](http://www.intersil.com/design/quality)

*Intersil products are sold by description only. Intersil Corporation reserves the right to make changes in circuit design, software and/or specifications at any time without notice. Accordingly, the reader is cautioned to verify that data sheets are current before placing orders. Information furnished by Intersil is believed to be accurate and reliable. However, no responsibility is assumed by Intersil or its subsidiaries for its use; nor for any infringements of patents or other rights of third parties which may result from its use. No license is granted by implication or otherwise under any patent or patent rights of Intersil or its subsidiaries.*

For information regarding Intersil Corporation and its products, see [www.intersil.com](http://www.intersil.com)