

**INTEGRATED WIRELESS POWER SUPPLY TRANSMITTER,  
Qi (WIRELESS POWER CONSORTIUM) COMPLIANT  
- Evaluation Board User's Guide (A11 type) -**

**FEATURES**

- Integrated wireless power transmitter controller
- WPC Ver. 1.1 ready
- MCU embedded
- Half-bridge gate driver : 4ch  
(full-bridge gate driver : 2ch also configurable)
- Single-coil (Type A11) supported
- Expanded free positioning using multi-coils up to 4 coils (Type A6)
- Highly accurate voltage and current monitor for inverters
- Output controlled by frequency or duty, defined in Qi.
- ASK demodulation for both current and voltage signals (Qi compliant)
- Input voltage range : VADP, VINV : 4.6 to 19.5V
- Supports Under Voltage Lockout , Thermal Shutdown, Over Current Detection
- Short-circuit protection at inverter output
- Temperature Detecting Circuit : 3ch
- LED indicator : 2ch
- package : 64 pins HQFP  
(size : 12mm × 12mm)

**DESCRIPTION**

NN32251A is a wireless power system controller IC which is compliant with Qi version 1.1 of the System Description Wireless Power Transfer, Volume 1 for Low Power, defined by Wireless Power Consortium.

NN32251A is a controller IC of a power transmitter (Tx) which can supply power to any Qi-compliant wireless chargers.

**APPLICATIONS**

- WPC-compliant wireless charger

**IMPORTANT**

NN32251A is designed to be used based on the circuits and external components described in this document .

Therefore, Panasonic cannot support any inquiries of modified solution.

**Wireless Power System**

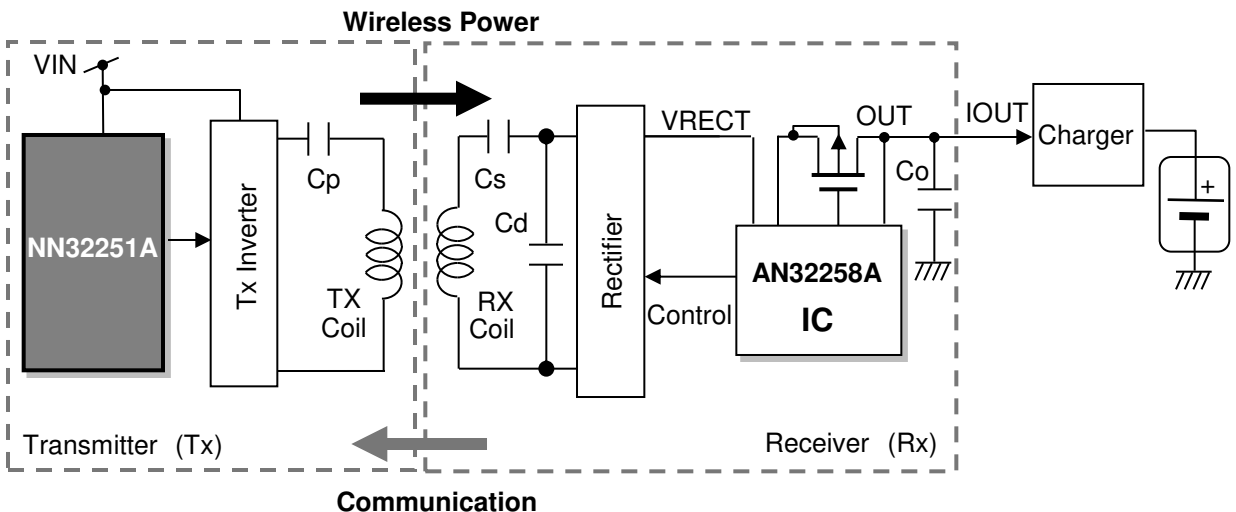

**EVB (for Qi Type A11) Information**

1. EVB Circuit Diagram

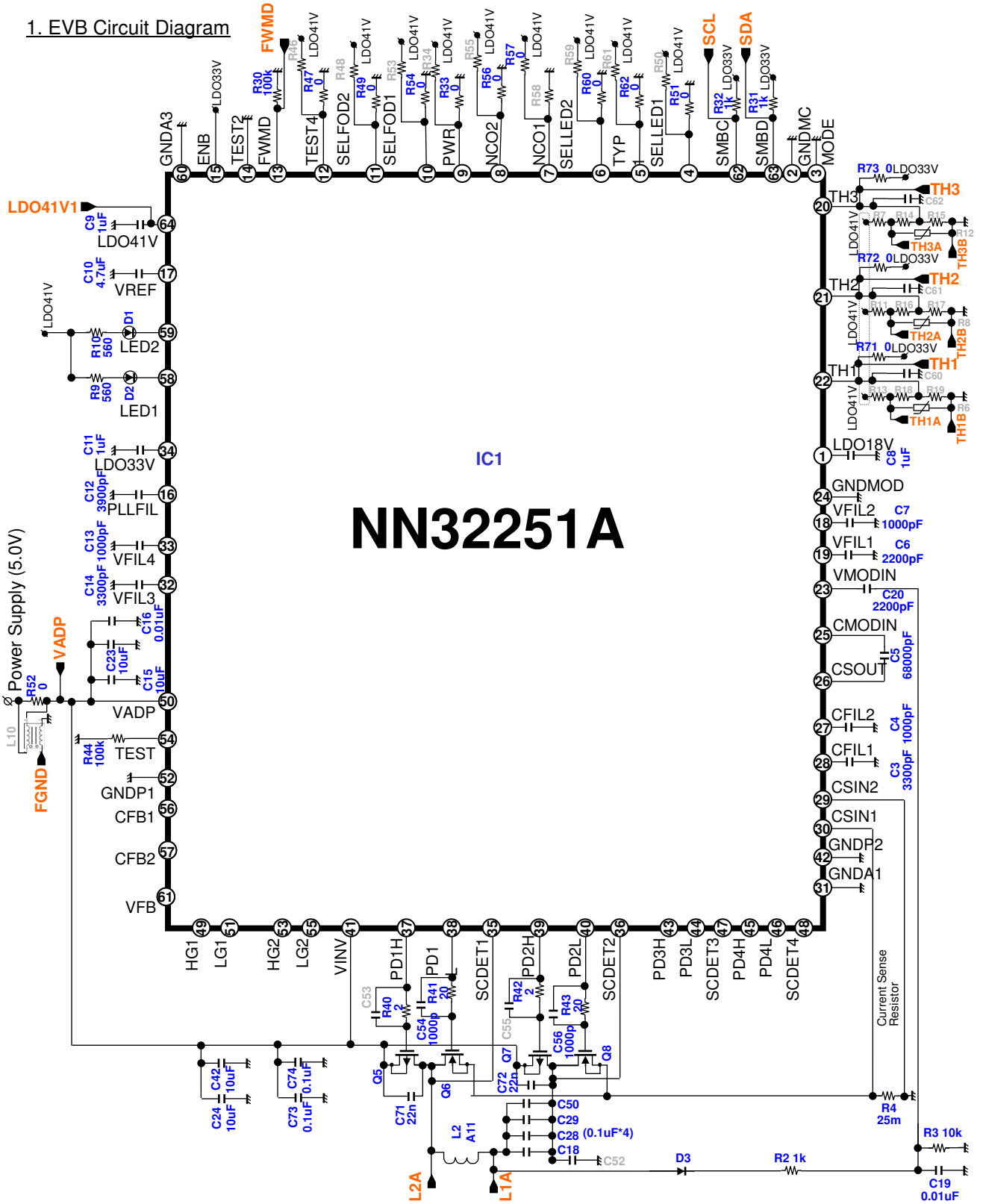

**EVB (for Qi Type A11) Information (Continued)**
**2. Bill of Materials**

Category	Parts No.	Name	Manufacture	Value	Rating	Size (JIS or PKG)	T(max) mm	Qty
IC	IC1	NN32251A	Panasonic	-	-	12.0 x 12.0	1.2	1
Coil	L2	CEBO-RA2D22A	CHEMTRONICS	-	-	-	-	1
Capacitor	C18,C28, C29,C50	C4532C0G2E104J320KN	TDK	0.1uF	250V	4.5 x 3.2	3.2	3
	C3, C14	GRM188B11E332KA01	MURATA	3300pF	25V	1.6 x 0.8	0.8	2
	C4, C7, C13, C54, C56	GRM188B11E102KA01	MURATA	1000pF	25V	1.6 x 0.8	0.8	5
	C6	GRM188B11E222KA01	MURATA	2200pF	25V	1.6 x 0.8	0.8	1
	C12	GRM188B11E392KA01	MURATA	3900pF	25V	1.6 x 0.8	0.8	1
	C5	GRM188B11E683KA01	MURATA	68000pF	25V	1.6 x 0.8	0.8	1
	C16	GRM188B11H103KA01	MURATA	0.01uF	50V	1.6 x 0.8	0.8	1
	C8, C9, C11	GRM188B31E105KA75	MURATA	1uF	25V	1.6 x 0.8	0.8	3
	C19	GRM188R72A103KA01	MURATA	0.01uF	100V	1.6 x 0.8	0.8	1
	C20	GRM188R72D222KW07D	MURATA	2200pF	200V	1.6 x 0.8	0.8	1
	C15,C23, C24,C42	UMK325AB7106MM-T	TAIYO YUDEN	10uF	50V	3.2 x 2.5	2.5	4
	C10	GRM21BB31E475KA75	MURATA	4.7uF	25V	2.1 x1.25	1.25	1
	C71, C72	GRM319R71H223JA01	MURATA	22nF	50V	3.2 x 1.6	0.95	2
C73, C74	GRM188R71H104KA93	MURATA	0.1uF	50V	1.6 x 0.8	0.8	2	
Resistor	R2, R31, R32	ERJ3EKF1001V	Panasonic	1K	1%	1.6 x 0.8	0.55	3
	R3	ERJ3EKF1002V	Panasonic	10K	1%	1.6 x 0.8	0.55	1
	R4	ERJ8BWFR025	Panasonic	25m	1%	3.2 x 1.6	0.75	1
	R9,R10	ERJ3EKF5600U	Panasonic	560	1%	1.6 x 0.8	0.55	2
	R30, R44	ERJ3EKF1003V	Panasonic	100K	1%	1.6 x 0.8	0.55	2
	R40, R42	ERJ3GEYJ2R0V	Panasonic	2	5%	1.6 x 0.8	0.55	2
	R41, R43	ERJ3GEYJ200V	Panasonic	20	5%	1.6 x 0.8	0.55	2
R33,R47, R49,R51, R52,R54, R56,R57, R60,R62, R71,R72, R73	ERJ3GEY0R00V	Panasonic	0	-	1.6 x 0.8	0.55	13	
Pch-MOSFET	Q5,Q7	SIA445EDJ	Vishay Siliconix			2.05 x 2.05	0.8	2
Nch-MOSFET	Q6,Q8	SIA400EDJ	Vishay Siliconix			2.05 x 2.05	0.8	2
LED	D1	LNJ337W83RA	Panasonic	green	-	1.6 x 0.8	0.25	1
LED	D2	LNJ237W82RA	Panasonic	red	-	1.6 x 0.8	0.25	1
Diode	D3	DA22F21	Panasonic	-	-	3.5 X 1.6	0.8	1

**EVB (for Qi Type A11) Information (Continued)**

3. EVB Layout

3-1. Evaluation Board

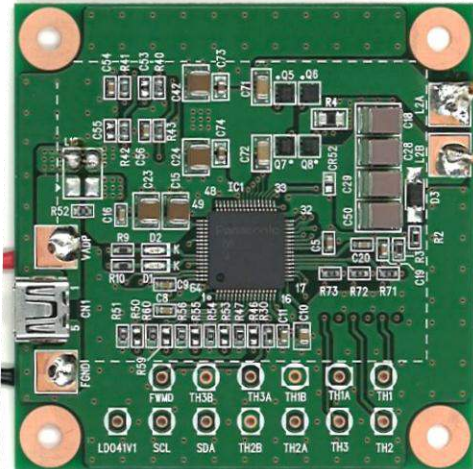

EVB Photo (Top)

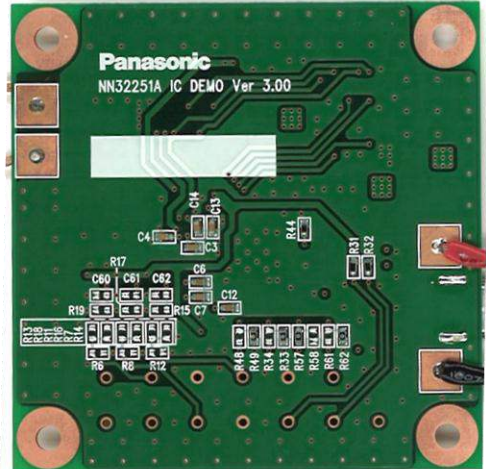

EVB Photo (Bottom)

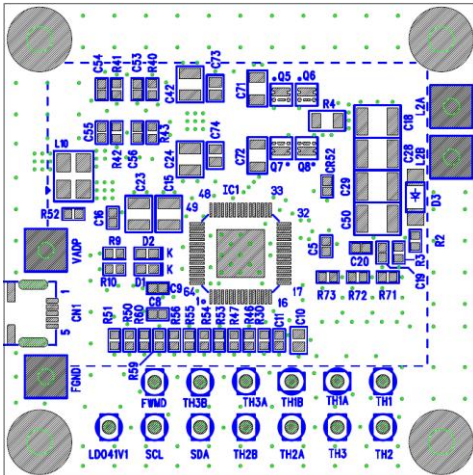

EVB Top Assembly

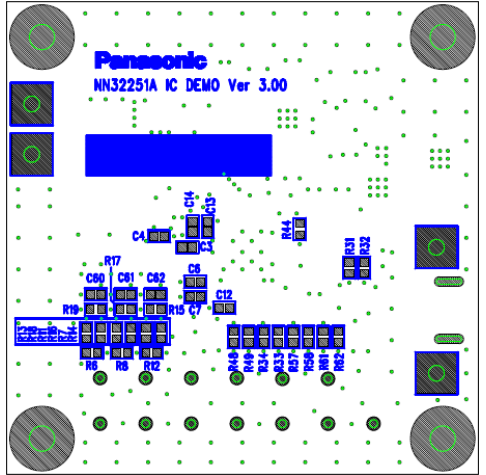

EVB Bottom Assembly

3-2. Specification of EVB

Category	Specification
EVB size	60.0 mm × 60.0 mm
Thickness	0.80 mm
Layer	4 layers

Note : The circuit and layout are designed for this evaluation board only. Thorough verification and evaluation must be done for the final product at your own risk.

## EVB (for Qi Type A11) Information (Continued)

### 4. The Whole Picture

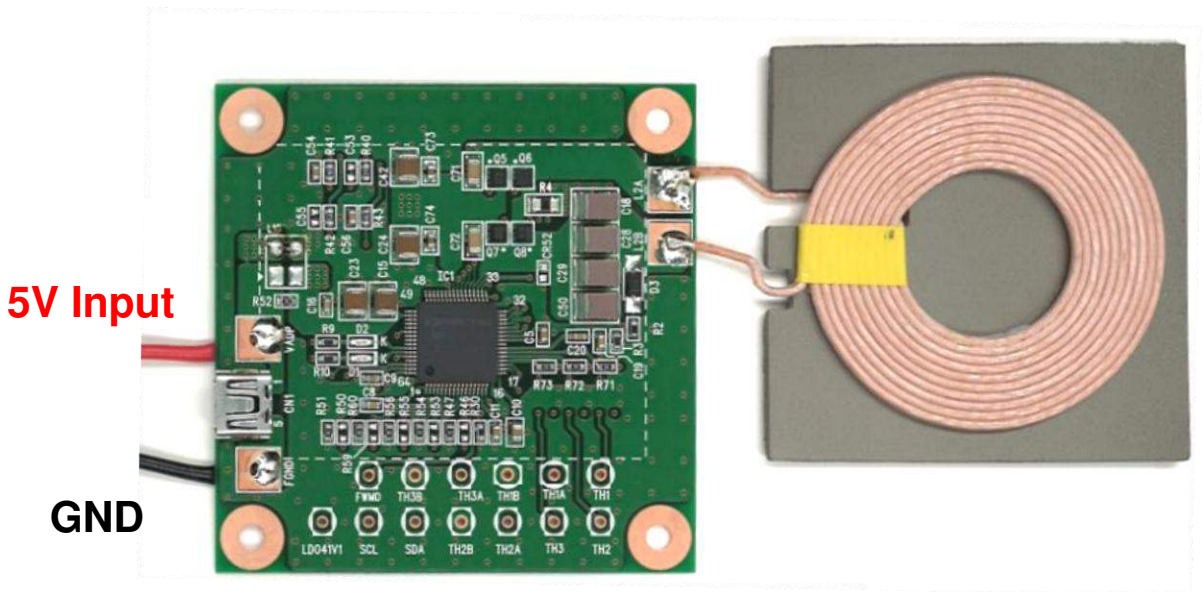

**EVB (for Qi Type A11) Information (Continued)**

5. LED Display

- Combination of LED display can be adjusted by pins SELLED1(No.4) and SELLED2(No.6) as the next table shows. Both pins are connected to GND on this board.

Pin Name (Number)		LED Pin	System Status			
			Selection	Ping ID & Configuration Power Transfer	Full Charge	Error Temperature Error
SELLED2 (No.6)	SELLED1 (No.4)		Charge			
			Standby	Charge	Full Charge	Error
GND	GND	LED1	OFF	ON	OFF	Blink
		LED2	OFF	OFF	ON	OFF
GND	LDO41V	LED1	OFF	OFF	OFF	ON
		LED2	OFF	Blink	ON	OFF
LDO41V	GND	LED1	ON	OFF	OFF	ON
		LED2	ON	Blink	ON	OFF
LDO41V	LDO41V	LED1	OFF	OFF	OFF	ON
		LED2	OFF	ON	OFF	OFF

**IMPORTANT NOTICE**

1. When using the IC for new models, verify the safety including the long-term reliability for each product.
2. When the application system is designed by using this IC, please confirm the notes in this book.  
Please read the notes to descriptions and the usage notes in the book.
3. This IC is intended to be used for general electronic equipment.  
Consult our sales staff in advance for information on the following applications: Special applications in which exceptional quality and reliability are required, or if the failure or malfunction of this IC may directly jeopardize life or harm the human body. Any applications other than the standard applications intended.
  - (1) Space appliance (such as artificial satellite, and rocket)
  - (2) Traffic control equipment (such as for automotive, airplane, train, and ship)
  - (3) Medical equipment for life support
  - (4) Submarine transponder
  - (5) Control equipment for power plant
  - (6) Disaster prevention and security device
  - (7) Weapon
  - (8) Others : Applications of which reliability equivalent to (1) to (7) is required

Our company shall not be held responsible for any damage incurred as a result of or in connection with the IC being used for any special application, unless our company agrees to the use of such special application.  
However, for the IC which we designate as products for automotive use, it is possible to be used for automotive.
4. This IC is neither designed nor intended for use in automotive applications or environments unless the IC is designated by our company to be used in automotive applications.  

Our company shall not be held responsible for any damage incurred by customers or any third party as a result of or in connection with the IC being used in automotive application, unless our company agrees to such application in this book.
5. Please use this IC in compliance with all applicable laws and regulations that regulate the inclusion or use of controlled substances, including without limitation, the EU RoHS Directive. Our company shall not be held responsible for any damage incurred as a result of our IC being used by our customers, not complying with the applicable laws and regulations.
6. Pay attention to the direction of the IC. When mounting it in the wrong direction onto the PCB (printed-circuit-board), it might be damaged.
7. Pay attention in the PCB (printed-circuit-board) pattern layout in order to prevent damage due to short circuit between pins. In addition, refer to the Pin Description for the pin configuration.
8. Perform visual inspection on the PCB before applying power, otherwise damage might happen due to problems such as solder-bridge between the pins of the IC. Also, perform full technical verification on the assembly quality, because the same damage possibly can happen due to conductive substances, such as solder ball, that adhere to the IC during transportation.
9. Take notice in the use of this IC that it might be damaged when an abnormal state occurs such as output pin-VCC short (Power supply fault), output pin-GND short (Ground fault), or output-to-output-pin short (load short). Safety measures such as installation of fuses are recommended because the extent of the above-mentioned damage will depend on the current capability of the power supply.
10. The protection circuit is for maintaining safety against abnormal operation. Therefore, the protection circuit should not work during normal operation.  

Especially for the thermal protection circuit, if the area of safe operation or the absolute maximum rating is momentarily exceeded due to output pin to VCC short (Power supply fault), or output pin to GND short (Ground fault), the IC might be damaged before the thermal protection circuit could operate.
11. Unless specified in the product specifications, make sure that negative voltage or excessive voltage are not applied to the pins because the IC might be damaged, which could happen due to negative voltage or excessive voltage generated during the ON and OFF timing when the inductive load of a motor coil or actuator coils of optical pick-up is being driven.
12. Verify the risks which might be caused by the malfunctions of external components.

## Request for your special attention and precautions in using the technical information and semiconductors described in this book

- (1) If any of the products or technical information described in this book is to be exported or provided to non-residents, the laws and regulations of the exporting country, especially, those with regard to security export control, must be observed.
- (2) The technical information described in this book is intended only to show the main characteristics and application circuit examples of the products. No license is granted in and to any intellectual property right or other right owned by Panasonic Corporation or any other company. Therefore, no responsibility is assumed by our company as to the infringement upon any such right owned by any other company which may arise as a result of the use of technical information described in this book.
- (3) The products described in this book are intended to be used for general applications (such as office equipment, communications equipment, measuring instruments and household appliances), or for specific applications as expressly stated in this book.  
Consult our sales staff in advance for information on the following applications:
  - Special applications (such as for airplanes, aerospace, automotive equipment, traffic signaling equipment, combustion equipment, life support systems and safety devices) in which exceptional quality and reliability are required, or if the failure or malfunction of the products may directly jeopardize life or harm the human body.It is to be understood that our company shall not be held responsible for any damage incurred as a result of or in connection with your using the products described in this book for any special application, unless our company agrees to your using the products in this book for any special application.
- (4) The products and product specifications described in this book are subject to change without notice for modification and/or improvement. At the final stage of your design, purchasing, or use of the products, therefore, ask for the most up-to-date Product Standards in advance to make sure that the latest specifications satisfy your requirements.
- (5) When designing your equipment, comply with the range of absolute maximum rating and the guaranteed operating conditions (operating power supply voltage and operating environment etc.). Especially, please be careful not to exceed the range of absolute maximum rating on the transient state, such as power-on, power-off and mode-switching. Otherwise, we will not be liable for any defect which may arise later in your equipment.  
Even when the products are used within the guaranteed values, take into the consideration of incidence of break down and failure mode, possible to occur to semiconductor products. Measures on the systems such as redundant design, arresting the spread of fire or preventing glitch are recommended in order to prevent physical injury, fire, social damages, for example, by using the products.
- (6) Comply with the instructions for use in order to prevent breakdown and characteristics change due to external factors (ESD, EOS, thermal stress and mechanical stress) at the time of handling, mounting or at customer's process. When using products for which damp-proof packing is required, satisfy the conditions, such as shelf life and the elapsed time since first opening the packages.
- (7) This book may be not reprinted or reproduced whether wholly or partially, without the prior written permission of our company.